

The Nissan logo is presented in a bold, black, sans-serif font. The word "NISSAN" is centered within a rounded rectangular border that has a thin black outline and a white fill. The letters are all uppercase and have a consistent, thick stroke weight.

**GT-R
Model
R32 Series**

Foreword

This service manual has been prepared primarily for the purpose of assisting service personnel in providing effective service and maintenance of the GT-R.

This manual includes procedures for maintenance, adjustments, removal and installation, disassembly and assembly of components, and trouble-shooting.

All information, illustrations and specifications contained in this manual are based on the latest product information available at the time of publication. If your car differs from the specifications contained in this manual, consult your NISSAN dealer for information.

The right is reserved to make changes to specifications and methods at any time without incurring any obligation to make or install similar changes on vehicles and/or parts previously purchased.

IMPORTANT SAFETY NOTICE

The proper performance of service is essential for both the safety of the mechanic and the efficient functioning of the vehicle.

The service methods in this Service Manual are described in such a manner that the service may be performed safely and accurately.

Service varies with the procedures used, the skills of the mechanic and the tools and parts available. Accordingly, anyone using service procedures, tools or parts which are not specifically recommended by NISSAN must first completely satisfy themselves that neither their safety nor the vehicle's safety will be jeopardized by the service method selected.

**GENERAL
INFORMATION**

ENGINE

CHASSIS

BODY

**HEATER &
AIR CONDITIONER**

**ELECTRICAL
SYSTEM**

SERVICE DATA

(Australian Design Changes – See Rear)

GENERAL INFORMATION

SECTION **GI**

CONTENTS

A1	HOW TO USE THIS MANUAL	GI- 2
A2	GENERAL PRECAUTIONS	GI- 5
A3	MODEL VARIATION	GI- 7
A4	VEHICLE AND UNIT IDENTIFICATION PLATE LOCATION	GI- 8
A5	TOW TRUCK TOWING	GI-10
A6	4WD INSPECTION AND REPAIR PRECAUTIONS	GI-11
A7	4WD VEHICLE TOWING PRECAUTIONS	GI-14

A1 HOW TO USE THIS MANUAL

1. Preparation Operation Explanation

This manual describes important items for installation, removal, assembly, disassembly, inspection and repair.

CAUTION:

A general description of a visual inspection and cleaning of disassembled parts has generally been omitted. However, when the parts will be used again, make sure to perform visual inspection and cleaning as necessary.

2. Configuration Components, Operation Contents and Procedures

The configuration components and operation contents and procedures are shown after the title of the operation. The preparation standards and important operation points such as parts which cannot be used again, tightening torque and lubrication locations are also indicated.

2-1 CONFIGURATION COMPONENTS AND OPERATION CONTENTS

The necessary operations for installation, removal, assembly and disassembly are indicated by the part (part name).

This description is used if the only ideal procedure cannot be determined or there are many types of components.

[Point] is used to indicate operation procedures which are necessary.

Example: Front accelerator assembly and disassembly

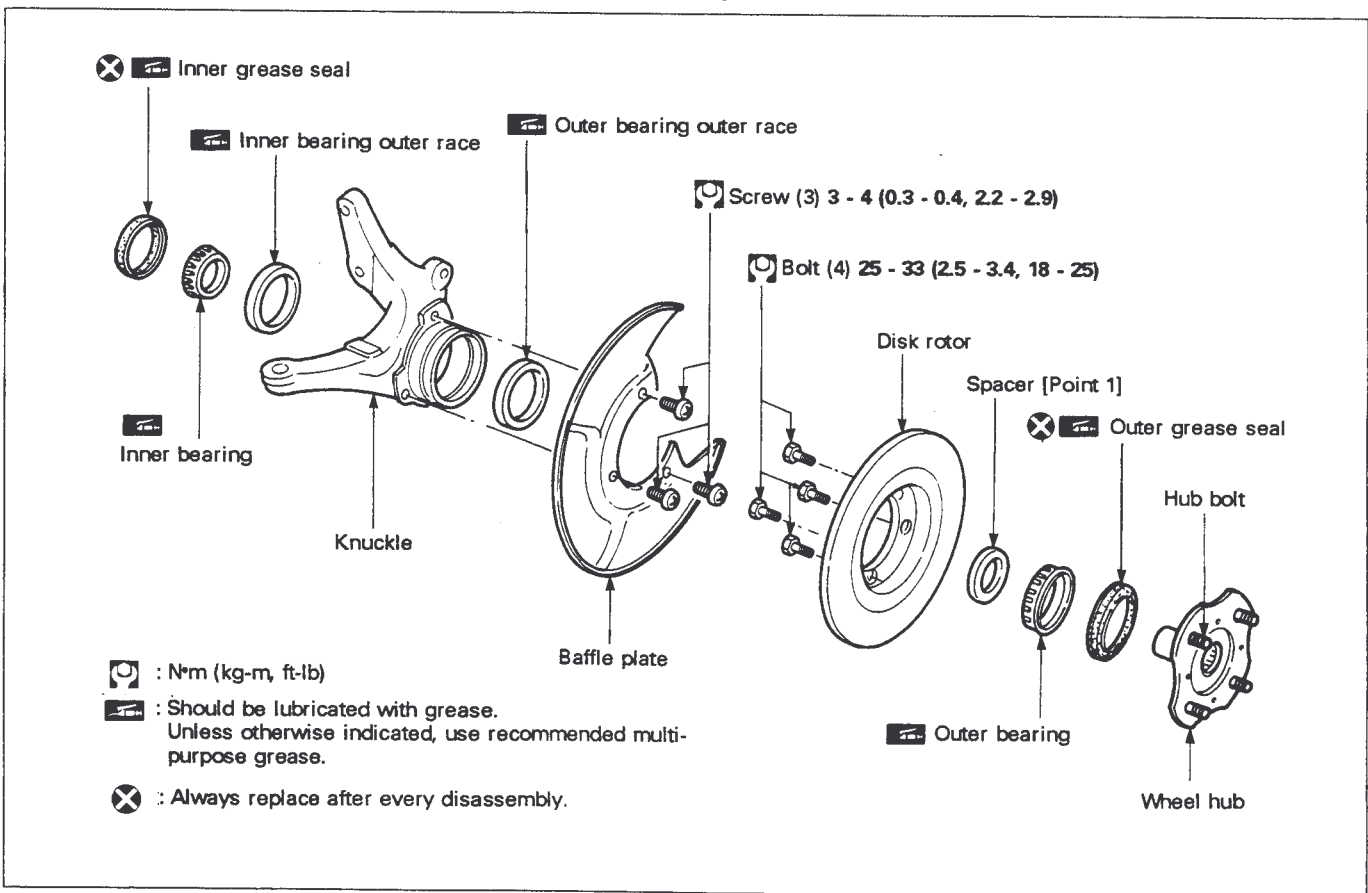

A1 HOW TO USE THIS MANUAL

2.Configuration Components, Operation Contents and Procedures (Cont'd)

2-2 STRUCTURAL PARTS DIAGRAM AND OPERATIONAL SEQUENCE

The names of the parts required for removal and replacement and assembly and disassembly operations are shown. The operational sequence must be performed in the sequence of the indicated numbers.

Assembly is the reverse of disassembly except when otherwise indicated.

Example: Light combination switch ASSY installation and removal

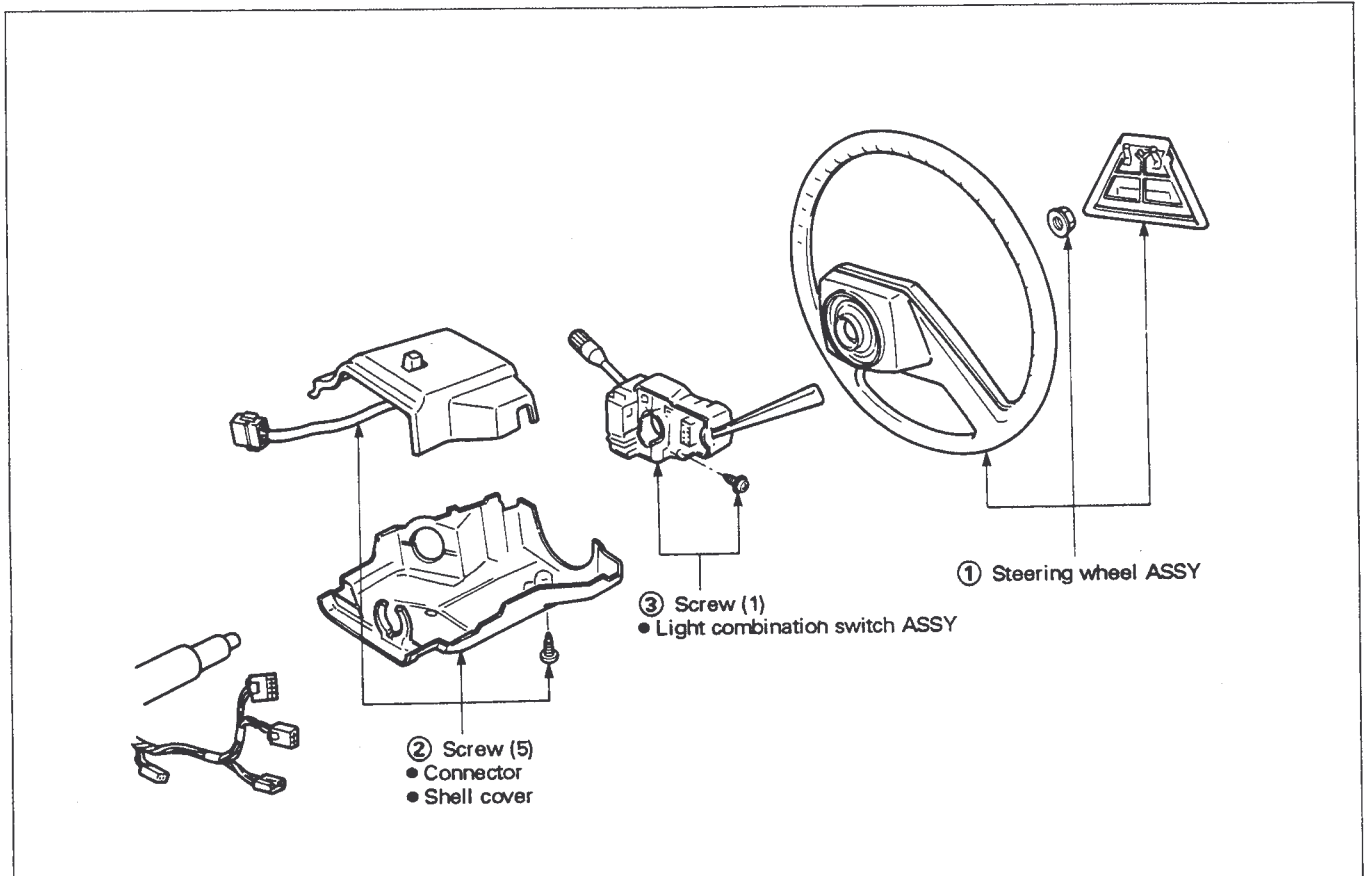

2-3 OPERATION NAME SYMBOLS

(1) (Removal) (Installation) (Additional work required)

(Removal): Indicates an operation (preparation, inspection adjustment, etc.) that is only necessary for removal.

(Installation): Indicates an operation (preparation, inspection adjustment, etc.) that is only necessary for installation.

(Removal) (Installation): Indicates an operation (preparation, inspection adjustment, etc.) that is only necessary for both removal and installation.

(Additional work required): Indicates a supplementary operation (removal, installation, etc.) to be performed before the operation indicated in the section title.

(2) : Tightening torque

Indicates an operation where the torque should be checked and the standard torque value that should be used.

When X to Y N·m (kg·m, ft·lb) is indicated, the standard tightening torque is the mean value.

(3) : Should be lubricated with grease. Indicates a type of grease.

(4) : Always replace after every disassembly.

(5) : Should be lubricated with oil.

(6) : Sealing point

(7) ★: Select proper parts.

(8) : Indicates when the CONSULT electronic system diagnosis is used.

: Indicates when the CONSULT electronic system diagnosis is not used.

A1 HOW TO USE THIS MANUAL

2.Configuration Components, Operation Contents and Procedures (Cont'd)

(9) [Point No.] ([Point 1], [Point 2], [Point 3])

These sections describe the techniques, special tools, and repair reference values required to perform operations properly .

A2 GENERAL PRECAUTIONS

1. Safety Precautions

- The RB26DETT engine exhaust valves contain metallic sodium. Be careful when using or discarding the valves. (Refer to section B3, 80, Cylinder Head Removal and Installation.)
- Do not operate the engine for an extended period of time without proper exhaust ventilation. Keep the work area well ventilated and free of any inflammable materials. Special care should be taken when handling any inflammable or poisonous materials, such as gasoline, refrigerant gas, etc. When working in a pit or other enclosed space, be sure to properly ventilate the area before working with hazardous materials.
Do not smoke while working on any vehicle.
- Before jacking up the vehicle, use wheel chocks or tire blocks on the wheels to prevent the vehicle from moving. After jacking up the vehicle, support the vehicle weight with safety stands at the points designated for proper lifting and towing before working on the vehicle.
These operations should be done on a level surface.
- When the automobile is lifted on a rigid rack, it should be supported in fixed locations.
- Before starting removal and installation of the electrical system or other repairs which do not require battery power, always turn off the ignition switch, then disconnect the ground cable from the battery to prevent accidental short circuits.

2. Fast, Accurate Operations

- Check the vehicle damage carefully, make a careful diagnosis of the damage and perform the correct operation systematically.
- Check the correct part assembly condition before removal or disassembly. Make alignment marks when necessary in locations which will not interfere with the part functions.
- Replace oil seals, gaskets, packings, O-rings, locking washers, cotter pins, self-locking nuts, etc. with new ones. These items are indicated, "Always replace after every disassembly." and must be replaced with a new part.
- Before servicing the vehicle, protect fenders, upholstery and carpeting with appropriate covers. Be careful so that keys, buckles or buttons on your person do not scratch the paint.
- Refer to the lubrication section and only use the lubricants which are described.
- When replacing parts always use genuine Nissan replacement parts.
- Verify the inspection circuit in a wiring figure before performing any inspection with a circuit tester.
- An inspection may be difficult with a normal test probe when a connector pin is extremely small. If this occurs, wind a small pin or wire around the test probe, or sharpen the end of the probe to perform the inspection.

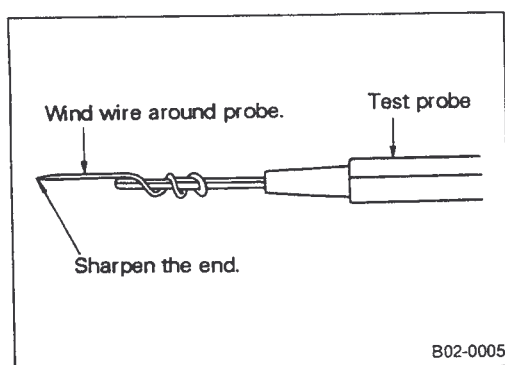

3. Electronic Trouble Diagnosis System

- Use measurement equipment such as the CONSULT electronic system diagnosis tester and an oscilloscope to perform diagnosis operations efficiently.
- The CONSULT unit is a hand-held compact type of tester. It transmits signals to the vehicle loading control units when the diagnosis connector is connected and can perform all types of diagnosis and testing.

A2 GENERAL PRECAUTIONS

3. Electronic Trouble Diagnosis System (Cont'd)

Main functions and applications

Diagnosis mode	Function	System	
		Engine	HICAS
Work support	Transmits commands to the electrical control unit for setting the status suitable for required operation.	○	
Self-diagnosis results	Receives the self-diagnosis results from the electrical control unit and displays malfunctioning system names and the number of times a malfunction occurs.	○	○
Data monitor	Receives input and output signals from the control unit, displays and records data used to easily determine cause of malfunction.	○	○
Active test	Sends commands to the control unit and performs the operation inspection and verification of the output system according to output signal changes.	○	○
E.C.U. part number	Displays the part number of the electrical control unit.	○	○

Note: Refer to the CONSULT Operation Manual for further details.

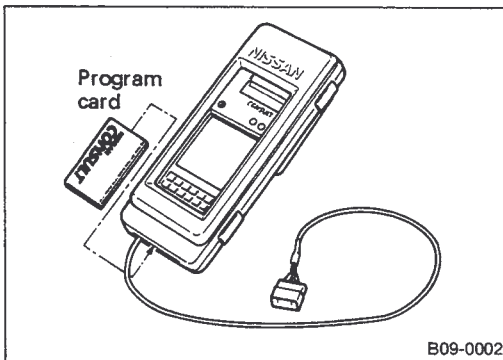

4. Environmental Protection

- Do not pour waste oil or cleaning fluids into a drain after an oil change. Use a disposal method that conforms to local laws.

A3 MODEL VARIATION

Drive system	Engine	Grade	Body type		Remarks
			4-door sedan	2-door coupe	Transmission
4WD	RB26DETT	GT-R	—	○	Manual 5-speed

A4 VEHICLE AND UNIT IDENTIFICATION PLATE LOCATION

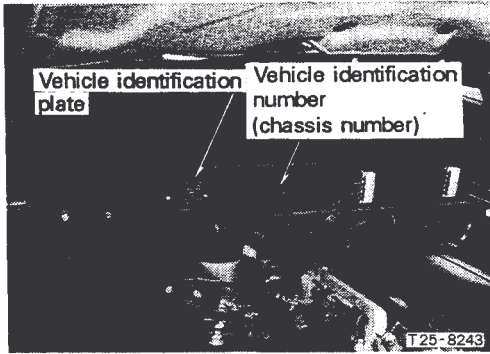

1. Vehicle Identification Plate and Starting Number

- E-BNR32 model BNR32-000001 - (equipped with RB26DETT engine)

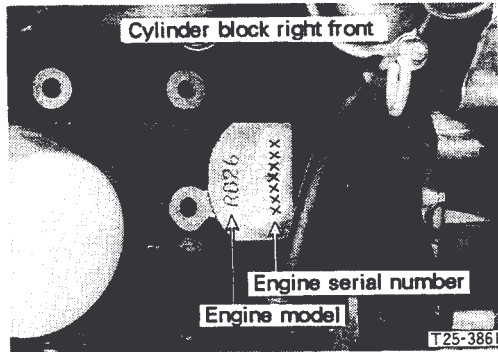

2. Engine Serial Number Location

RB26DETT Engine

A5 TOW TRUCK TOWING

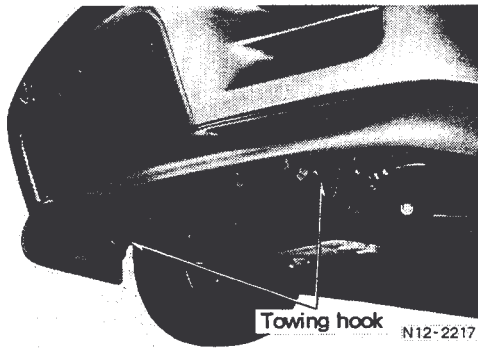

1. Towing

Front side

- After removing front spoiler, attach a cable to the hook in the front part of the front side member.

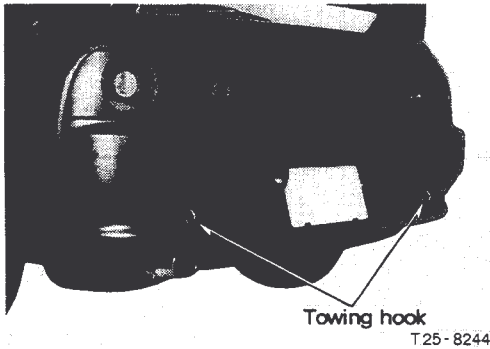

Rear

- Attach a cable to the hook mounted in the rear part of the rear side member.

2. 2-pole Lift

- The 2-pole lifting points are the same as for the rigid rack.

CAUTION:

- (1) Make sure vehicle is empty when lifting.
- (2) When lifting the vehicle, make sure the side sill and lift arm (rear part) do not contact each other.

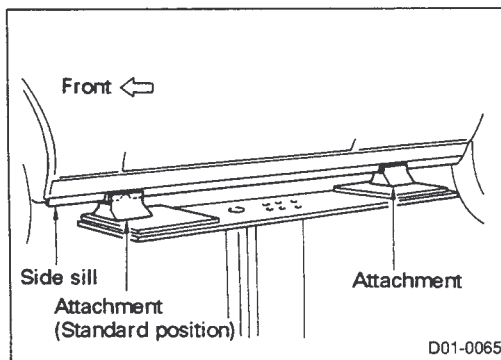

3. Board-on Lift

- The board-on lift attachment (LM4086-0200) set at the front end of the vehicle should be set on the front of the sill under the front door opening.
- Position attachments at front and rear ends of board-on lift.

CAUTION:

Make sure vehicle is empty when lifting.

A5 TOW TRUCK TOWING

4. Hydraulic Jack Lifting and Jack Stand Support

CAUTION:

- (1) Make sure vehicle is empty when lifting.
- (2) When the front side is jacked up, raise the front sill edge slightly using the jack and then jack the vehicle up.
- (3) Use the attachment (LM4519-0000) whenever a vehicle is supported by jack stands.
- (4) When using jack stands, be careful not to allow the jack stand to crush brake tubes or fuel lines.

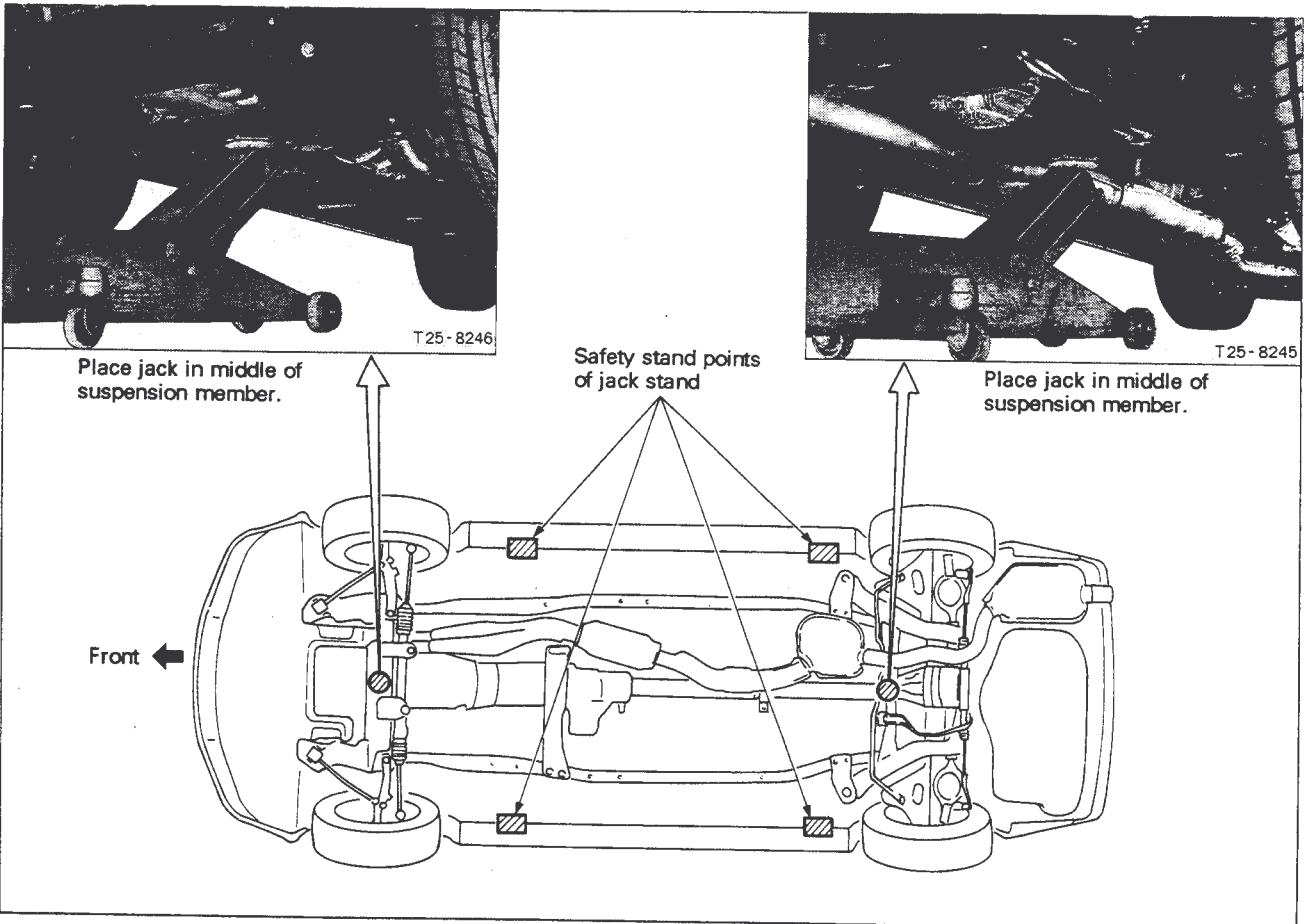

A6 4WD INSPECTION AND REPAIR PRECAUTIONS

Observe the following precautions to measure the speedometer reading and to check braking performance in the 4WD mode.

1. Speedometer Measurement

The two methods to measure the speedometer are described below.

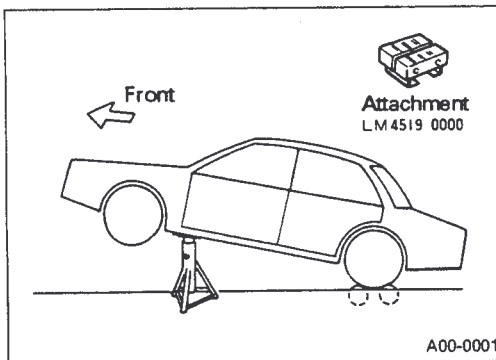

(1) Measurement with front wheels jacked up

- Place the rear wheels on the roller.
- Use the attachment to lift up the front wheels and support the car on jack stands as shown in the figure on the left.
- Place the transmission in 2nd gear and gradually release the clutch.
- When the test is completed, do not apply the brakes suddenly.

CAUTION:

- (1) Place the jacks securely, and perform the measurement after making sure the vehicle is stable.
- (2) Use the free rollers described below whenever possible.

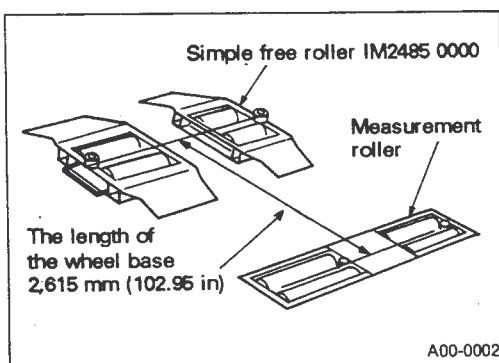

(2) Measurement with simple free roller

- Set the simple free roller the length of the wheel base [2,615 mm (102.95 in)] forward of the middle of the measurement roller as shown in the figure on the left.

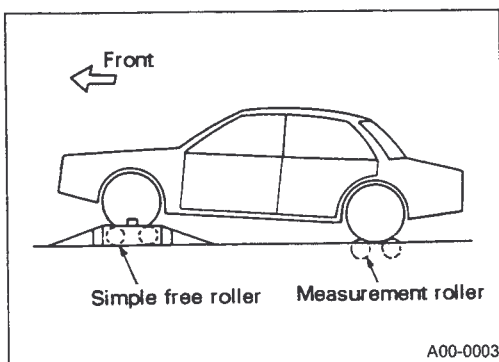

- Place the front wheels on the simple free rollers and the rear wheels on the measurement rollers.
- Place the transmission in 2nd gear and gradually release the clutch.
- When the test is completed, do not apply the brakes suddenly.

A6 4WD INSPECTION AND REPAIR PRECAUTIONS

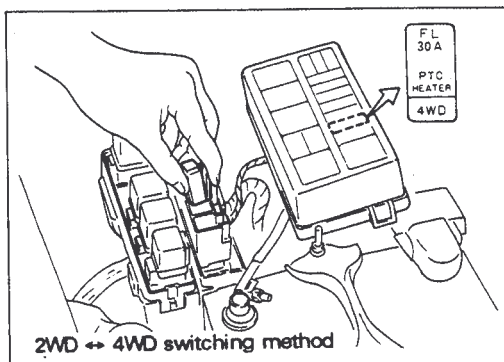

2. Braking Performance Check

2-1 PRE-INSPECTION PREPARATIONS

- The performance check must be performed in the 2WD mode. To set the 2WD mode, either use the front propellor shaft removal method or remove the fusible link from the engine compartment. Use the method most suitable for the test location.

A6 4WD INSPECTION AND REPAIR PRECAUTIONS

2. Braking Performance Check (Cont'd)

2-2 INSPECTION POINTS (when fusible link in engine compartment is removed)

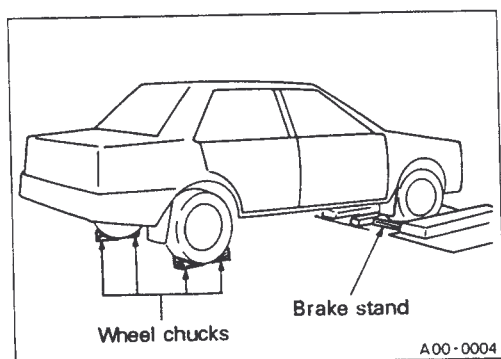

Stop engine and remove the 4WD fusible link 30A from the engine compartment relay box.

Start the engine. Repeat the engine deceleration operation from full throttle to no throttle until the 4WD warning lamp on instrument panel lights.

NOTE: The vehicle may not enter 2WD mode when this operation is performed.

Make sure the 4WD warning lamp lights, then turn key switch off once.

Start engine again and make sure the 4WD warning lamp lights.

Position vehicle on rollers, set shift and range into neutral position.

Press brake pedal. Release pedal when OK zone is reached or OK lamp lights.

NOTE: If the drag force exceeds 10% of the axle weight when the drag test is performed, the wheel rotation must be checked with the vehicle jacked up. If there is no abnormality at this time, it can be assumed that the drag is caused by the viscous torque and there is no brake abnormality.

Stop the engine and install the fusible link in the normal location.

Restart engine and make sure the 4WD warning lamp goes off and 4WD mode is set.

End

A7 4WD VEHICLE TOWING PRECAUTIONS

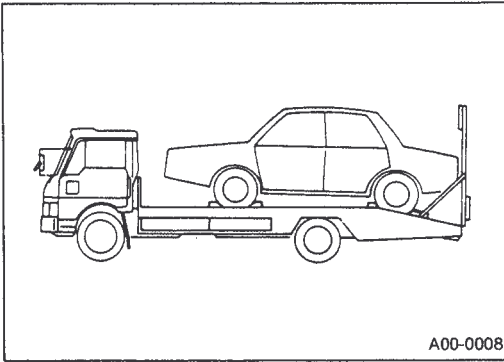

1. Towing Precautions

- Never tow a 4WD model with front or rear wheels raised and opposite rear or front wheels on the ground as this may cause serious and expensive damage to the transaxle.

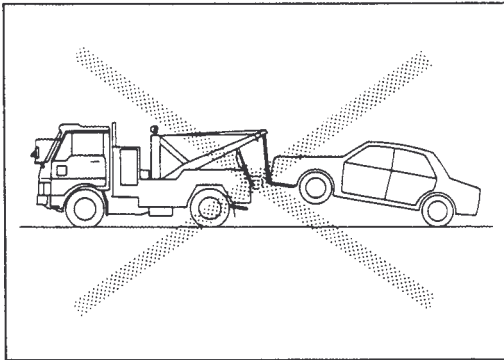

CONTENTS

B ENGINE

B1 ENGINE SPECIFICATIONS	EN- 3
1.Main Engine Specifications	EN- 3
2.Emission Control Equipment Specification	EN- 4
3.System Diagram	EN- 5
4.Vacuum Diagram	EN- 6
B2 RB26 DOHC EGI (ECCS) TWIN-TURBOCHARGER ENGINE	EN- 7
1.Idle Inspection and Adjustment	EN- 7
2.Compression Pressure Inspection	EN- 16
3.Belt Tension Inspection and Adjustment	EN- 17
4.Valve Clearance Inspection and Adjustment	EN- 19
5.Lubrication System Inspection	EN- 32
6.Exhaust System Inspection	EN- 23
7.Fuel System Inspection	EN- 25
8.Evaporative Gas Control System Inspection	EN- 26
9.Blowby Gas Reduction Equipment Inspection	EN- 26
10.Removal and Installation of On-vehicle Parts	EN- 27
11.Engine Removal and Installation	EN- 89
12.Oil Pan, Oil Pump and Oil Strainer Removal and Installation	EN- 92
13.Engine Overhaul	EN- 98
B3 ECCS (Electronically Concentrated Engine Control System)	EN-119
1.Trouble Diagnosis	EN-120
2.Diagnostic System	EN-150
3.Basic Inspection	EN-165
4.System Figure and Circuit Diagram	EN-169
5.Actuator System Inspection	EN-174
6.Sensor System Inspection	EN-203
7.ECCS Control Unit Input/Output Signals (RB26DETT)	EN-234
8.Deceleration Exhaust Gas Emission Control Equipment Inspection	EN-245
9.Air Conditioner Cut System Inspection	EN-245

B4 ENGINE ELECTRICAL EQUIPMENT	EN-246
1.Battery Inspection	EN-247
2.Alternator	EN-247
3.Starter Motor Removal and Installation	EN-248
4.Platinum Plug Inspection	EN-248
5.Ignition Coil Inspection	EN-248
B5 COOLING SYSTEM	EN-249
1.Radiator Inspection	EN-249
2.Radiator Cap Inspection	EN-250
3.Cooling Water Filling Procedures	EN-250
4.Radiator Removal and Installation	EN-251
5.Thermostat Inspection	EN-252
6.Sub Electrical Fan Inspection	EN-252
7.Sub Electrical Fan Removal and Installation	EN-253
B6 FUEL SYSTEM	EN-254
1.Fuel Tank Removal and Installation	EN-255
2.Fuel Gauge ASSY	EN-257
3.Fuel Pump Removal and Installation	EN-258
B7 EXHAUST SYSTEM	EN-260
1.Exhaust Pipe, Catalytic Converter and Heat Panel Tightening Torques	EN-261
2.Exhaust Temperature Warning Equipment Inspection	EN-261
B8 ENGINE CONTROL	EN-262
1.Accelerator Pedal Inspection and Adjustment	EN-262
B9 ENGINE MOUNTING (4WD)	EN-263
1.Front Engine Mounting (RB26DETT)	EN-263
2.Rear Engine Mounting (RB26DETT)	EN-263

B1 ENGINE SPECIFICATIONS

1. Main Engine Specifications

		Model	E-BNR32
		Engine	RB26DETT
Displacement		cm ³ (cu in)	2,568 (156.70)
Combustion chamber			Pent-roof type
Valve arrangement			DOHC belt drive
Bore × stroke		mm (in)	86.0 × 73.7 (3.386 × 2.902)
Compression ratio			8.5
Compression pressure		kPa (kg/cm ² , psi)/rpm	1,177 (12.0, 171)/300
Dimensions (L × W × H)		mm (in) M/T	870 × 665 × 675 (34.25 × 26.18 × 26.57)
Valve opening and closing cycle	Intake valve opening angle (BTDC)		(degrees) 7
	Intake valve closing angle (BBDC)		(degrees) 53
	Exhaust valve opening angle (BBDC)		(degrees) 63
	Exhaust valve closing angle (BTDC)		(degrees) 7 (BTDC)
Valve clearance	Intake (warm)		mm (in) 0.51 (0.020)
	Exhaust (warm)		mm (in) 0.44 (0.017)
Idle speed		(rpm) M/T	950
Ignition timing		(BTDC°/rpm) M/T	20/950
Preparation target value	Idle CO density		(%) 0.1 max.
	Idle HC density		(ppm) 50 max.
Engine oil (factory)	Standard		7.5W-30 (SG grade for turbo)
	Cold climate version		
Oil pan capacity (H level)		ℓ (Imp qt)	4.5 (4)
Oil filter capacity		ℓ (Imp qt)	Approx. 0.4 (3/8)
Total engine coolant capacity		ℓ (Imp qt)	Approx. 9.0 (7-7/8)

Use recommended genuine Nissan SG grade engine oil [Turbo X (7.5W-30)] or equivalent.

B1 ENGINE SPECIFICATIONS

2. Emission Control Equipment Specification

	Model	E-BNR32
Item	Engine	RB26DETT
Engine fuel system		ECCS (MPi)
Air/fuel ratio control system		Air/fuel ratio feedback
Temperature control air cleaner		—
Supplemental start equipment		Bi-metal type air regulator
Intake heat system		Hot water heating
Ignition system		Breakerless type (ECCS electrical distributor)
NOx reduction equipment	EGR control system	—
	TV valve operation temperature °C (°F)	—
CO, HC (NOx) reduction equipment	Catalyzer type	Three-way catalyst
	Catalytic converter size [capacity in liters (Imp qt)]	X3 [1.7 (1-1/2)]
Deceleration exhaust gas reduction equipment	Fuel cutoff equipment	○
Exhaust gas temperature warning equipment [setting temperature °C (°F)]		Thermocouple [850 (1,562)]
Evaporative gas control system		Canister system
Blowby gas reduction system		Closed system

B1 ENGINE SPECIFICATIONS

3. System Diagram

3-1 RB26 DOHC — EGI (ECCS) TWIN-TURBOCHARGER ENGINE

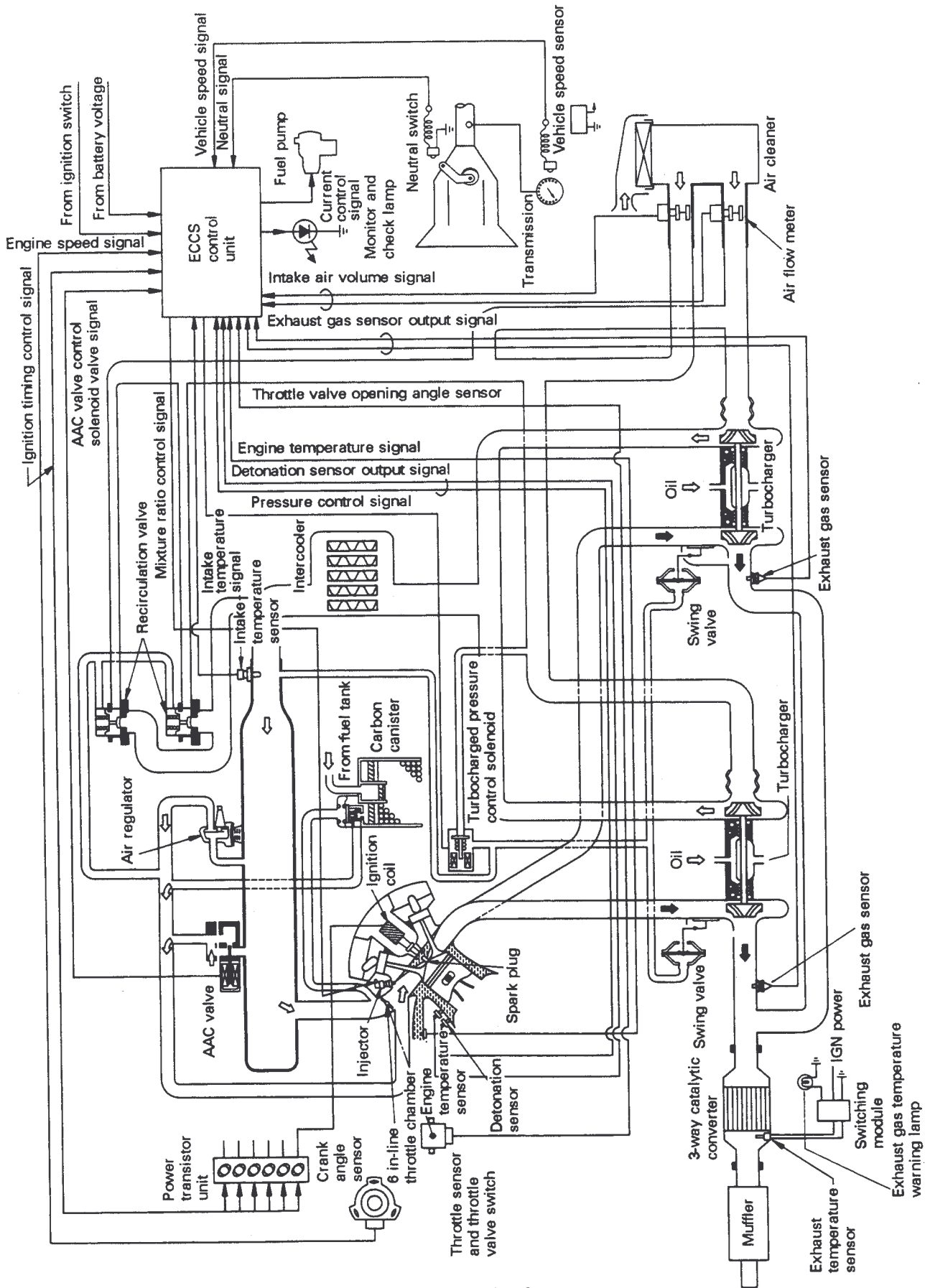

B1 ENGINE SPECIFICATIONS

4. Vacuum Diagram

4-1 RB26 DOHC EGI (ECCS) TWIN-TURBOCHARGER ENGINE

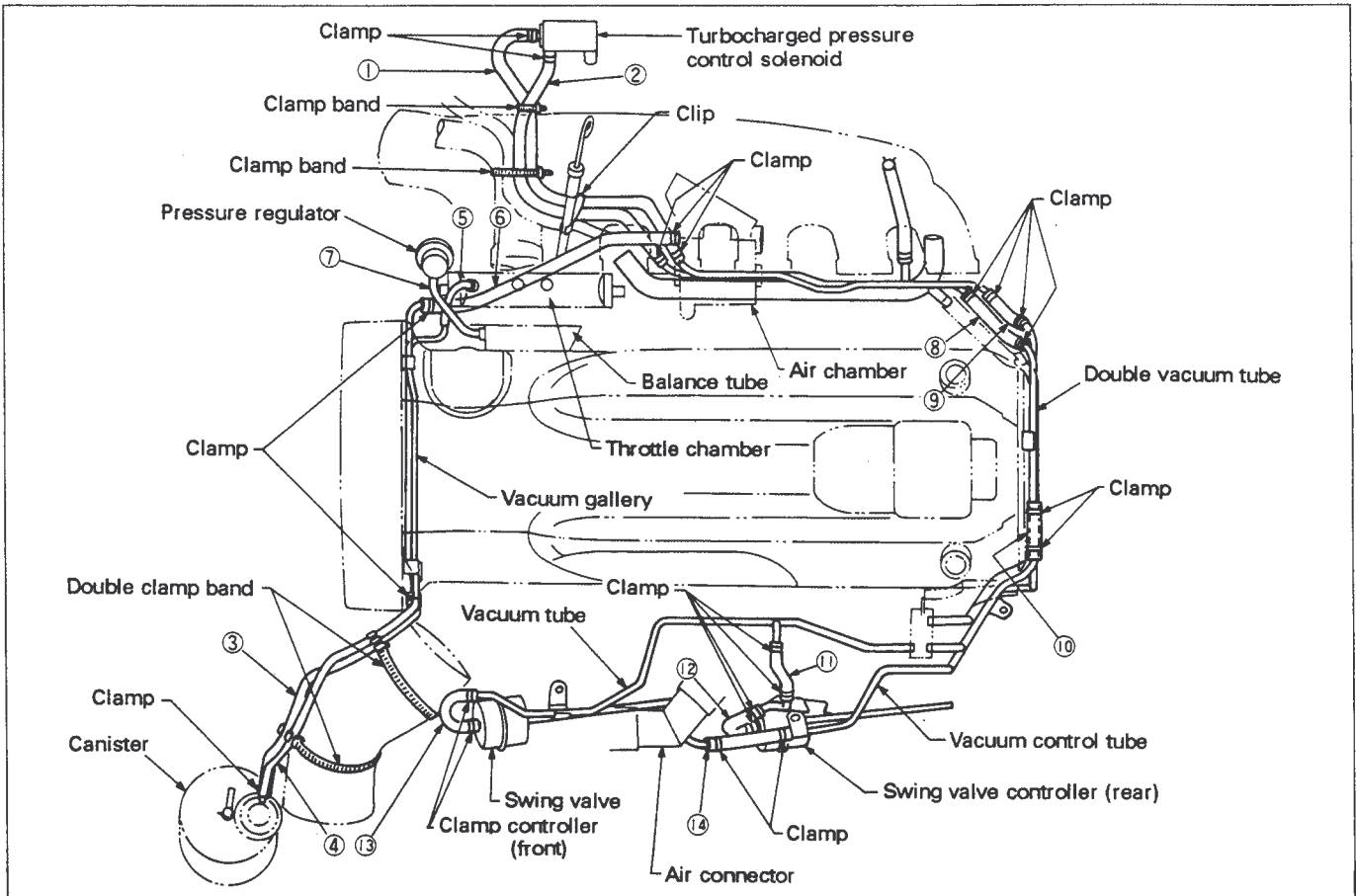

Number	Length mm (in)	Part
①	580 (22.83)	Turbocharged pressure control solenoid - vacuum gallery
②	560 (22.05)	Turbocharged pressure control solenoid - vacuum gallery
③	425 (16.73)	Canister - vacuum gallery
④	425 (16.73)	Canister - vacuum gallery
⑤	80 (3.15)	Throttle chamber - vacuum gallery
⑥	290 (11.42)	Air chamber - vacuum gallery
⑦	Molded	Pressure regulator - balance tube
⑧	120 (4.72)	Vacuum gallery - vacuum gallery
⑨	90 (3.54)	Vacuum gallery - vacuum gallery
⑩	60 (2.36)	Vacuum gallery - vacuum gallery
⑪	90 (3.54)	Vacuum gallery - vacuum gallery
⑫	Molded	Vacuum gallery - swing valve controller (rear)
⑬	Molded	Vacuum gallery - swing valve controller (front)
⑭	90 (3.54)	Vacuum gallery - vacuum control tube

B2 RB26 DOHC EGI (ECCS) TWIN-TURBOCHARGER ENGINE

1. Idle Inspection and Adjustment

Tools required

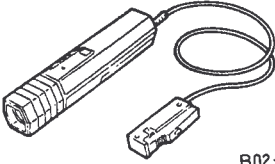
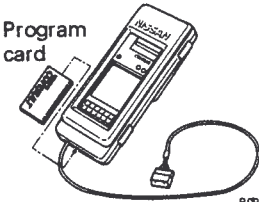
	Name	Use
Measurement tool	Super tuner After number EG1151-9000, EG1152-9000, EG1153-9000 and EG1154-9000	Otherwise, tachometer tester (after number EG1334-9000)
	Timing light (internal battery) EG1444 0000	 B02-1498
	CO and HC meter	Measures CO and HC levels.
	Electronic system diagnosis tester CONSULT EG1180 0000	 B09-0001

Idle standard values

	Engine	RB26DETT
Item		
Idle speed (when air conditioner is ON)	(rpm)	950 (950)
Ignition timing	(BTDC°/rpm)	20/950
CO/HC density	(%) (ppm)	0.1 max, 50 max.

CAUTION:

The idle speed, ignition timing, CO and HC density are inter-related. Any adjustment to one affects the others and requires an additional inspection.

B2 RB26 DOHC EGI (ECCS) TWIN-TURBOCHARGER ENGINE

1. Idle Inspection and Adjustment (Cont'd)

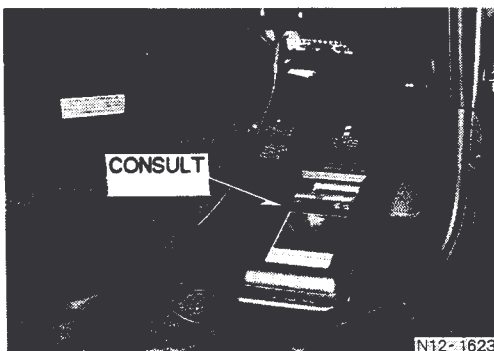
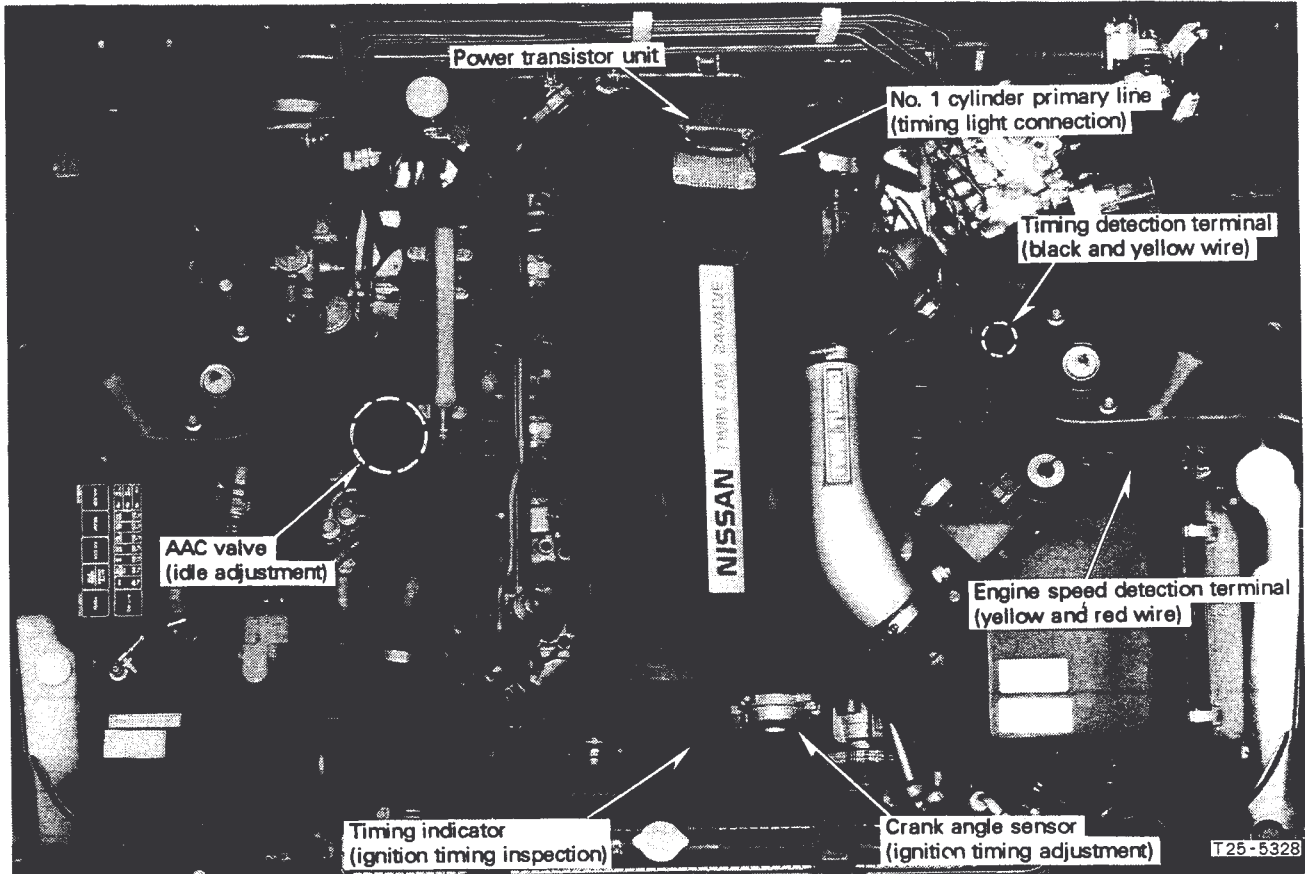
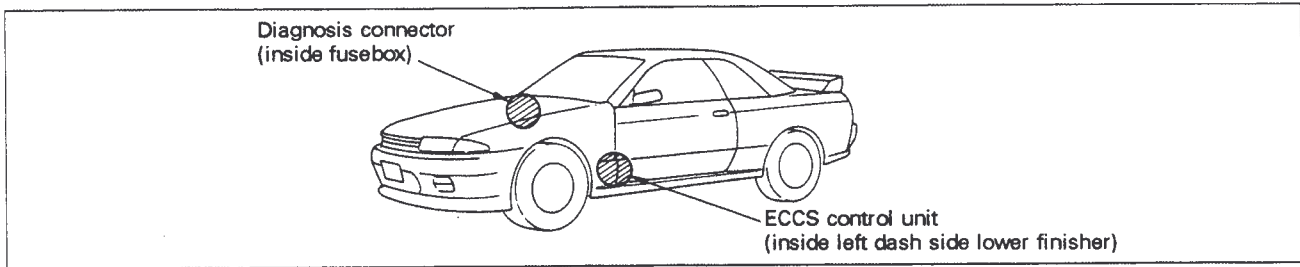

1-1 IDLE SPEED INSPECTION AND ADJUSTMENT

Engine speed measurement unit



- Warm engine adequately.
- Connect CONSULT to diagnosis connector on vehicle (attached to fuse block area). Turn ignition switch to ON.
- "DIAGNOSIS MODE SELECTION" is displayed.

Note: Refer to section B3, 2, 2-2 (2) for details.

B2 RB26 DOHC EGI (ECCS) TWIN-TURBOCHARGER ENGINE

1. Idle Inspection and Adjustment (Cont'd)

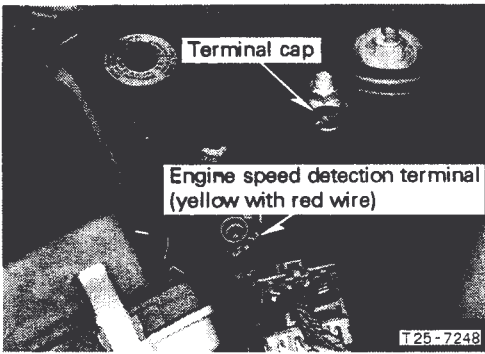

- Connect the measurement unit to the speed detection terminal in the harness connected to the ignition coil from the power transistor.

- After the measurement is completed, always replace the terminal cap in the detection terminal.

CAUTION:

Be sure to check the tachometer specifications because a 6V voltage is generated.

Inspection

- Warm engine adequately.
- Make sure air conditioning load, power steering oil pump load and electrical loads are not applied.



- Check "IDLE POS" and "CAS - RPM -(POS)" in "DATA MONITOR" mode in CONSULT unit.



- Perform inspection using engine speed measurement.

Note: The measurement unit is limited because the speed output voltage is low (approx. 6V Vp-p).

CAUTION:

Before inspection, make sure the throttle valve switch (idle connection point) is on when the accelerator pedal is not pressed.

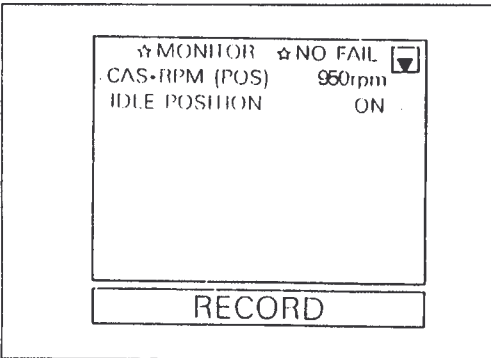

Adjustment

The idle speed adjustment is basically not necessary because the rated value (control target value) is returned to the control unit. If adjustment becomes necessary, perform the following procedures:



- ① Select "AAC valve adjustment" in the "WORK SUPPORT" mode. Turn AAC valve assembly idle adjustment screw with a screwdriver until idle speed is 900 rpm.

- ② Return the "AAC VALVE ADJUSTMENT" screen to "DATA MONITOR" and check idle speed shown on screen meets the specification.

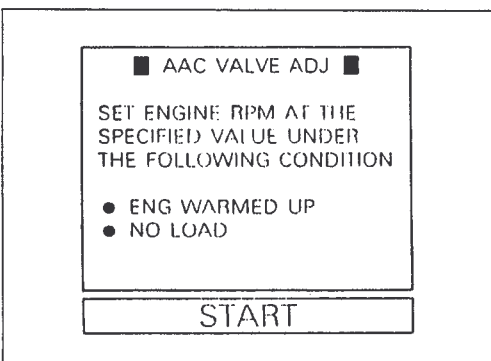

B2 RB26 DOHC EGI (ECCS) TWIN-TURBOCHARGER ENGINE

Caution
Adjust within
indicated range.
Do not turn with excessive force.

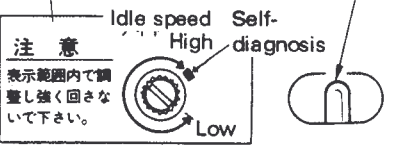

B02-3427

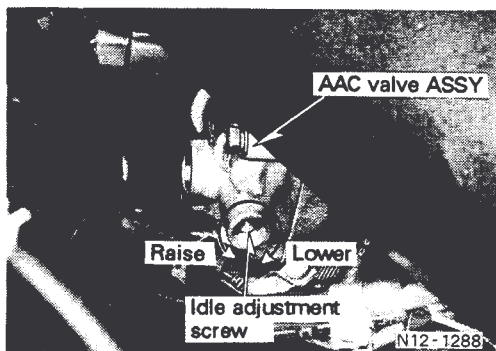
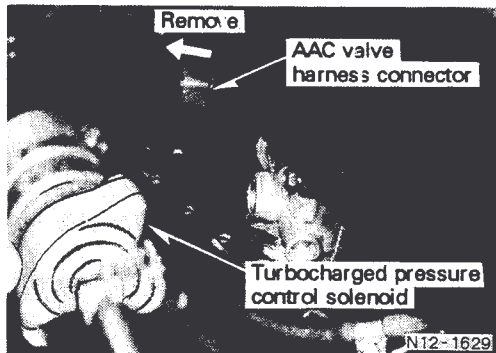

Caution
Adjust within
indicated range.
Do not turn with excessive force.

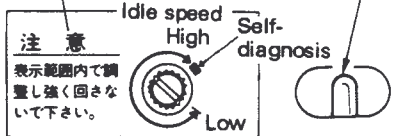

B02-3427

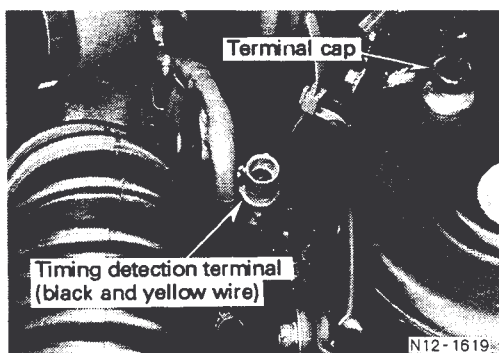

1. Idle Inspection and Adjustment (Cont'd)



- ① Make sure ECCS control unit idle control adjustment volume is turned all the way to the left.

CAUTION:

Never turn idle control speed adjustment volume with excessive force. The adjustment screw turning range is 3/4 of a turn.

- ② Remove the 2-pin harness connector from the AAC valve to stop the idle speed feedback control. The AAC valve is completely closed at this time and the idle speed should be 900 rpm maximum under normal conditions.

- ③ Turn the AAC valve assembly idle adjustment screw with a screwdriver to adjust engine speed to 900 rpm.
- ④ Connect AAC valve harness connector. Make sure idle speed is maintained at specified value. The engine speed increases when adjustment screw is turned to left (CCW) and decreases when turned to the right (CW).

- ⑤ If idle speed increases for any reason, turn idle control adjustment volume in ECCS control unit to adjust speed. Idle adjustment volume increases engine speed when turned to right by a maximum 250 rpm.

CAUTION:

The adjustment volume must be set 40° - 50° from the self-diagnosis position because idle speed is lowered (lowest rpm + 50 rpm) if it is turned all the way to the right (self-diagnosis position).

1-2 IGNITION TIMING CHECK AND ADJUSTMENT

Timing light connection

- (1) When using "super tuner"

- Connect super tuner to timing detection terminal.

CAUTION:

After operation is completed, always attach terminal cap to timing detection terminal (check connector).

B2 RB26 DOHC EGI (ECCS) TWIN-TURBOCHARGER ENGINE

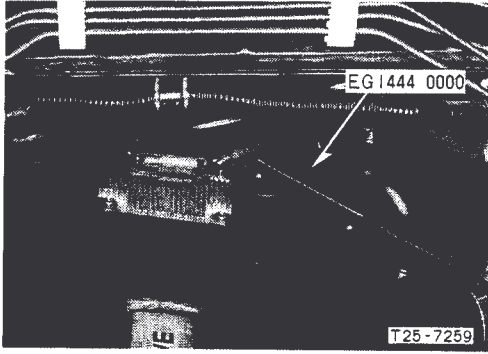

1. Idle Inspection and Adjustment (Cont'd)

(2) Using primary current detector timing light

- When using EG1444 0000, attach sensor to No. 1 cylinder primary line.
(No. 1 cylinder primary line is looped because it is longer than other cylinder primary lines.)

CAUTION:

When using EG1444 0000 (internal battery model), make sure that the sensor direction (arrow direction) faces spark plug when sensor is clipped to primary line.

(If primary line direction is not clear, measure with sensor connected in both directions. The correct installation direction is indicated when lower advanced angle value is obtained.)

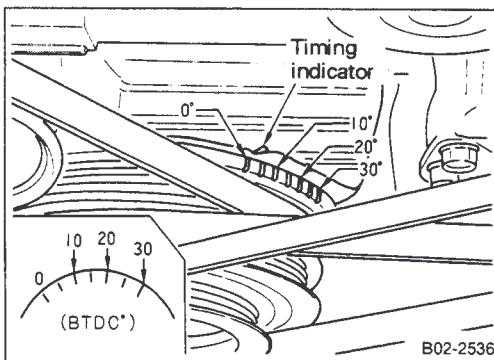
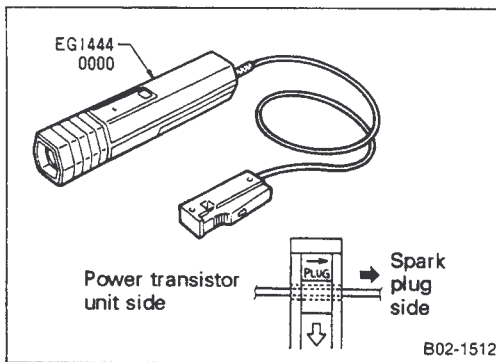

Inspection

- Make sure idle speed is standard value.
- Make sure ignition timing at engine idle is at standard specification.
- Make sure ignition advances to correct advance angle when engine is raced.

CAUTION:

The 0° timing mark on crank pulley is orange and other points are painted white.

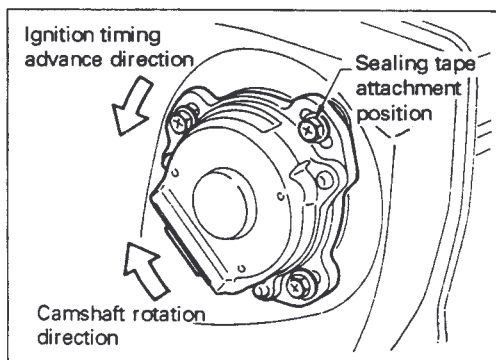

Adjustment

Since there is no variation in ignition timing, over an extended time period, ignition timing adjustment is not necessary in principle. Adjust ignition timing when crank angle sensor is installed.

- Set ignition timing by adjusting crank angle sensor installation position.
- Make sure idle speed is standard.
- Loosen the three crank angle sensor mounting bolts and rotate crank angle sensor. Turn sensor to left to advance ignition timing.

B2 RB26 DOHC EGI (ECCS) TWIN-TURBOCHARGER ENGINE

1. Idle Inspection and Adjustment (Cont'd)

- After adjustment, attach sealing tape to one of the three bolts that secure crank angle sensor.

Sealing tape part number	B2235 U7410
--------------------------	-------------

B2 RB26 DOHC EGI (ECCS) TWIN-TURBOCHARGER ENGINE

1. Idle Inspection and Adjustment (Cont'd)

1-3 CO, HC DENSITY INSPECTION

The air/fuel ratio feedback system which has a self-learning function is used and CO and HC density adjustment is not necessary because the correction range is wide.

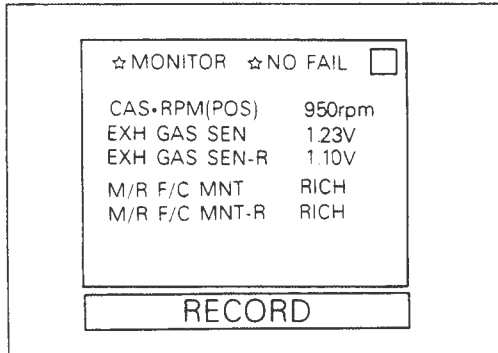

Short these pins for approximately two seconds then open them, the diagnosis mode will then change. (The mode changes each time this operation is performed.)

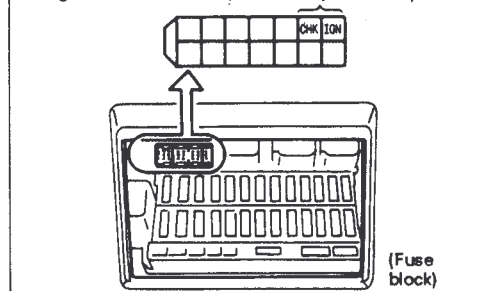

Caution
Adjust within indicated range.
Do not turn with excessive force.

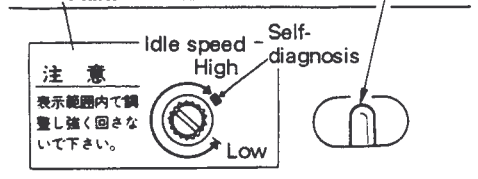

B02-3427

Inspection

- Warm up the engine adequately and make sure the idle speed and ignition timing are standard. Check CO, HC density with CO and HC meter.
- If values do not conform to standard perform the following procedures to inspect the air/fuel feedback condition:



- ① In the data monitor mode, select "EXHAUST GAS SENSOR MONITOR" and "EXHAUST GAS SENSOR MONITOR (R)".
- ② Set the engine speed above 2,000 rpm and make sure "RICH" and "LEAN" are displayed alternately.



- Short-circuit the self-diagnosis connector on the vehicle side (near fuse box installation). Otherwise, remove ECCS control unit and operate adjustment volume on control unit side.

- ① Set the ignition switch "ON" and use a lead line to short-circuit the CHK pin and IGN pin of the diagnosis connector for more than two seconds to release the setting. (Otherwise turn the ignition switch to "ON" and turn the adjustment volume on the side of the ECCS control unit to the right (CW) until it stops in the self diagnosis switching position **B** for more than two seconds and then return it to the original position.)

B2 RB26 DOHC EGI (ECCS) TWIN-TURBOCHARGER ENGINE

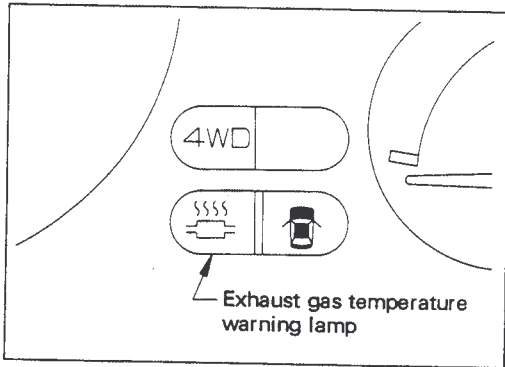

1. Idle Inspection and Adjustment (Cont'd)

- ② After warming up the engine adequately, raise the engine speed until the exhaust temperature warning lamp (or the red lamp on side of control unit) flashes (the flashing will start above approximately 2,000 rpm). The exhaust gas sensor output monitor (R) mode will be set.

CAUTION:

The accelerator pedal must be pressed intentionally during idling to perform the inspection because the air/fuel ratio feedback control is stopped.

- ③ Make sure the exhaust gas temperature warning lamp or red lamp on the side of the control unit flashes in this condition.

Short these pins for approximately two seconds then open them, the diagnosis mode will change. (The mode changes each time this operation is performed.)

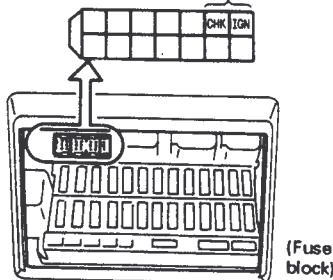

- ④ Use a lead to short the CHK pin and the IGN pin of the diagnosis connector for more than two seconds one more time to release the self-diagnosis mode. (Otherwise turn the adjustment volume of the ECCS control unit side to the right (CW) until it stops to select the self-diagnosis mode **B** for more than two seconds and then return it to the original position).

Note: Refer to section (B3, 2, Diagnosis System) for explanation of air fuel feedback monitor.

Exhaust gas sensor monitor mode switching display

- ① Set the ignition switch to "ON". Use a lead line to short CHK pin and IGN pin of diagnosis connector for more than two seconds to switch mode.

(Otherwise turn ignition switch to "ON" and turn adjustment volume on side of the ECCS control unit to the right (CW) until it stops at self-diagnosis mode switching position

B for more than two seconds and then return volume to original position.)

Switching the signal for exhaust gas sensor → exhaust gas sensor (R) Exhaust gas sensor output monitor

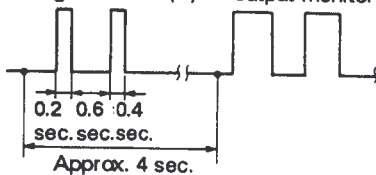

B09-0089

Switching the signal for exhaust gas sensor (R) → exhaust gas sensor Exhaust gas sensor output monitor

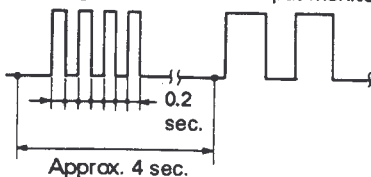

B09-0090

- ② After warming the engine adequately, raise the engine speed until the exhaust gas temperature warning lamp (or the red lamp on side of control unit) flashes (the flashing will start above approximately 2,000 rpm). The rear exhaust gas sensor output monitor mode will be set.

CAUTION:

The accelerator pedal must be pressed intentionally during idling to perform the inspection because the air-fuel ratio feedback control is stopped.

B2 RB26 DOHC EGI (ECCS) TWIN-TURBOCHARGER ENGINE

1. Idle Inspection and Adjustment (Cont'd)

- ③ Make sure the exhaust gas temperature warning lamp or red lamp on the side of the control unit flashes in this condition.
- ④ Short CHK pin and IGN pin of the diagnosis connector for more than two seconds one more time to release the mode. (Otherwise, turn the adjustment volume on side ECCS control unit to the right (CW) until it stops at self-diagnosis mode switching position **B** for more than two seconds and then return volume to original position.) After the exhaust gas temperature warning lamp (or red lamp on control unit side) flashes two times, the mode switches to the front exhaust gas sensor output monitor mode.
- ⑤ Make sure that the exhaust gas temperature warning lamp (or red lamp on side of control unit) flashes at about 2,000 rpm.

Note: Refer to section B3, 2, Self-diagnosis System for details about air/fuel ratio feedback monitor.

Note: When switching the exhaust gas sensor output monitor from the No. 1-3 cylinder bank to No. 4-6 cylinder bank, adjust the diagnosis connector (or control unit adjustment volume). The signal pattern is shown in the diagrams.

B2 RB26 DOHC EGI (ECCS) TWIN-TURBOCHARGER ENGINE

2. Compression Pressure Inspection

Tools required

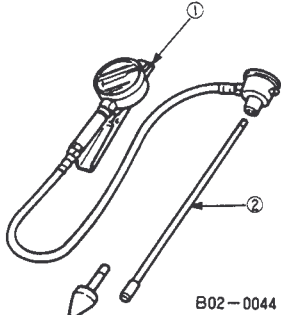
	Name		Application
Tool	Spark plug wrench EG1740 1600 (or other regular spark plug wrench set)	 B02-0045	Removal and installation of small size hexagonal spark plug
Measurement tool	Engine speed measurement unit		To check engine speed.
	① Allen compression gauge EG1505 0000 ② Compression gauge adaptor EG1505 0101	 B02-0044	For engine compression pressure inspection.

Compression pressure standard values

Item	Engine	RB26DETT
Standard value	kPa (kg/cm ² , psi)/rpm	1,177 (12.0, 171)/300
Limit value	kPa (kg/cm ² , psi)/rpm	883 (9.0, 128)/300
Compression variance limit between cylinders	kPa (kg/cm ² , psi)/rpm	98 (1.0, 14)/300

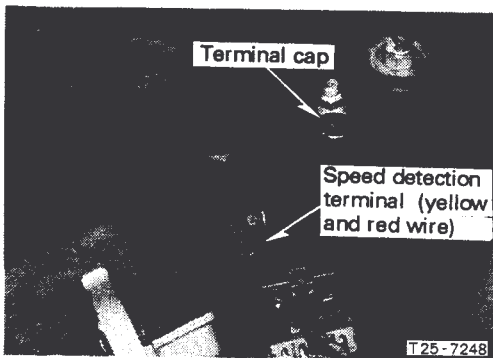

Engine speed measurement unit installation

- Connect the engine speed measurement unit to the speed detection pin on the harness connected to the ignition coil from the power transistor.
- Always attach the terminal cap with rubber seal after measurement is completed.

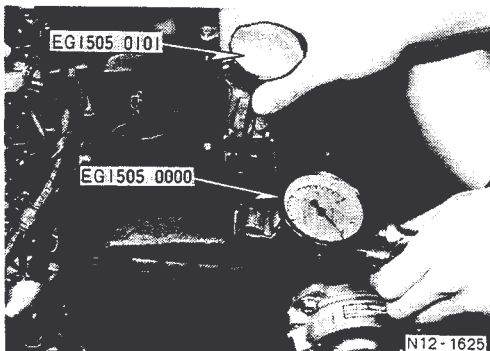

Compression gauge installation

- Warm up engine.
- Release fuel pressure.
(Refer to "Releasing fuel pressure" section B2, 7-1.)
- Remove all spark plugs. (Refer to "SPARK PLUGS" section B2, 10-9.)
- Attach the adaptor to the Allen compression gauge and set it in a spark plug hole.

B2 RB26 DOHC EGI (ECCS) TWIN-TURBOCHARGER ENGINE

2. Compression Pressure Inspection (Cont'd) Inspection

- Press accelerator pedal all the way down. Turn ignition switch to "START" and crank the engine. When gauge needle stops moving read compression pressure and engine speed.
- When engine speed is out of specifications, check specific gravity of the battery and perform test again if battery is functioning properly.
- If the compression pressure is still not standard, inspect the components around the combustion chamber (valves, valves seat, hydraulic valve lifters, piston rings, cylinder bore, cylinder head, cylinder head gasket, etc.). Correct any malfunctions and repeat compression test.

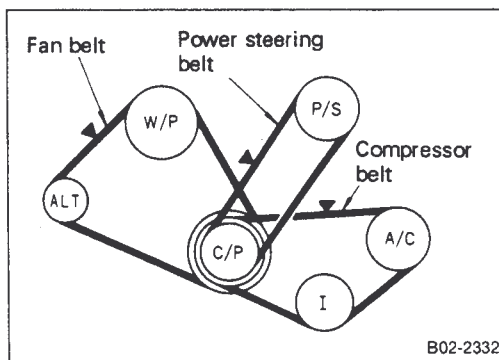

3. Belt Tension Inspection and Adjustment

Inspection

- The inspection should be performed when the engine is cold or more than thirty minutes after the engine has stopped.

Part	Item	Belt specification	Belt deflection mm (in) [When 98 N (10 kg, 22 lb) of force is applied at the "▼" position.]		
			New	Adjustment	Tension limit
Power steering belt		Poly-V low-maintenance belt	8 - 10 (0.31 - 0.39)	10 - 12 (0.39 - 0.47)	16 (0.63)
Air conditioner compressor belt		Poly-V low-maintenance belt	6 - 8 (0.24 - 0.31)	7 - 9 (0.28 - 0.35)	12 (0.47)
Fan belt		Poly-V low-maintenance belt	3 - 5 (0.12 - 0.20)	4 - 6 (0.16 - 0.24)	7.5 (0.295)

CAUTION:

- (1) When the belt is replaced with a new belt increase the tension slightly more than for the used belt to allow for wear-in of the new belt.
- (2) When the belt deflection exceeds the limit, adjust to the "Adjustment" value.
- (3) When the belt is installed, make sure pulley groove is aligned correctly.

B2 RB26 DOHC EGI (ECCS) TWIN-TURBOCHARGER ENGINE

3. Belt Tension Inspection and Adjustment. (Cont'd)

Adjustment

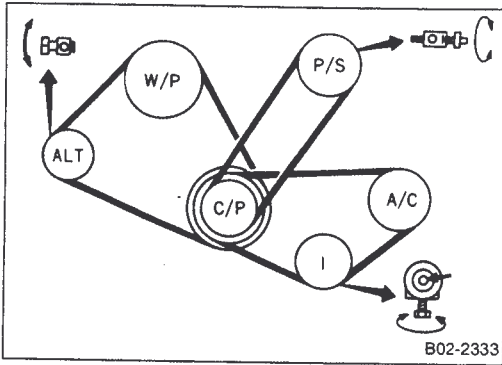

Part	Item	Adjustment position
Power steering belt		Adjustment bolt in power steering pump
Air conditioner compressor belt		Adjustment bolt in idler pulley
Fan belt		Adjustment bolt in alternator

B2 RB26 DOHC EGI (ECCS) TWIN-TURBOCHARGER ENGINE

4. Valve Clearance Inspection and Adjustment

Additional work required:

Remove the following parts:

- Air duct
- Rocker cover (Refer to "SPARK PLUGS and ROCKER COVER REMOVAL AND INSTALLATION" section B2, 10-9, 10.)

Inspection

- Adjust valve clearance while engine is cold.
- Remove the air duct, ornaments and rocker cover.
- Turn crankshaft and align crankshaft pulley mark with belt cover indicator.
- No. 1 cylinder is at the compression stroke top dead center when both the intake and exhaust side cams do not move the valve lifters.

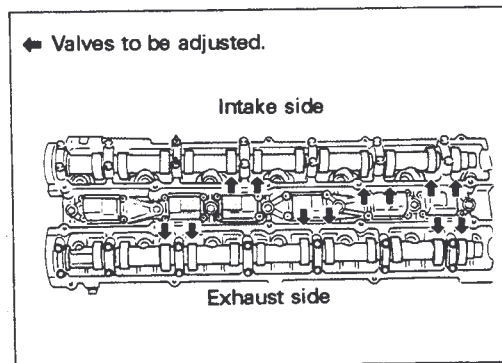
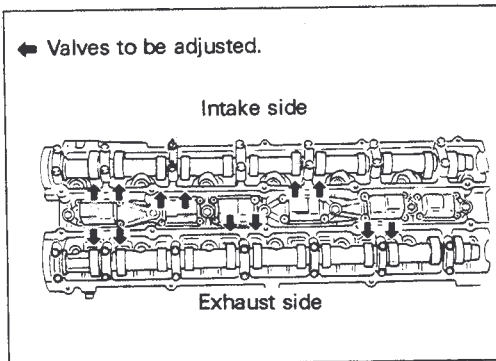

Item	Part	Valve clearance measurement
	Intake side	Cylinder No. 1, 2, 4
	Exhaust side	Cylinder No. 1, 3, 5

Firing order: 1-5-3-6-2-4

- Turn crankshaft one revolution (360°) and align mark on crankshaft pulley with belt cover indicator. (No. 1 cylinder piston exhaust T.D.C.)

Item	Part	Valve clearance measurement
	Intake side	Cylinder No. 3, 5, 6
	Exhaust side	Cylinder No. 2, 4, 6

Valve clearance standard values

[20 ± 5°C (68 ± 9°F)]

Item	Part	Intake	Exhaust
Valve clearance (cold)	mm (in)	0.45 ± 0.03 (0.018 ± 0.001)	0.38 ± 0.03 (0.015 ± 0.001)
(Reference value: warm)	mm (in)	0.51 ± 0.03 (0.020 ± 0.001)	0.44 ± 0.03 (0.017 ± 0.001)

CAUTION:

Always check valves when they are cold.

4. Valve Clearance Inspection and Adjustment (Cont'd)

Valve clearance measurement

- Insert a 0.15 - 0.20 mm (0.0059 - 0.0079 in) feeler gauge **(A)** from spark plug side.
- Insert feeler gauges **(B)** from opposite side. Select a gauge thickness that will reduce the clearance to 0 mm (0 in).

Note: ● Do not use more than two gauges for **(B)**.
 ● The feeler gauge must conform to JIS (Japanese Industrial Standard) 150A25.

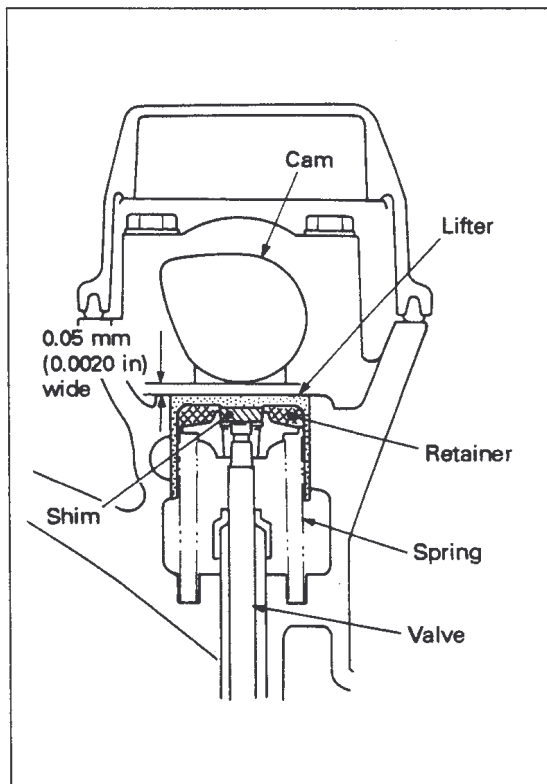
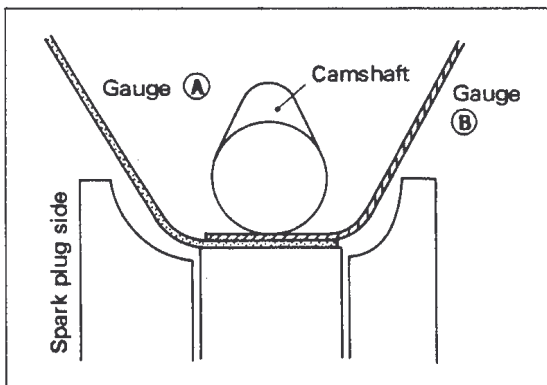

- Valve clearance = gauge **(A)** + gauge **(B)**

Reasons for measurement using gauges **(A)** and **(B)**:

- ① The valve clearance setting is larger compared to previous engines.
 - ② Larger gauges cannot be placed parallel to the measurement surface.
- Thick feeler gauge blades have a high rigidity and do not bend easily, so the measurement will be incorrect.
 - The error factor increases if a number of thin gauges are layered and the measurement will be incorrect.

Valve clearance adjustment

- The valve clearance adjustment is performed by selecting and inserting a shim of suitable thickness.
- When the measurement valve clearance (t) is out of specification, measure the shim thickness (T) and replace it with a shim that will produce the standard clearance.

① Shim thickness calculation method

Example: When the intake valve clearance (t) is 0.50 mm (0.020 in):

$$0.50 (t) - 0.45 (\text{specified value}) = 0.05 \text{ mm (0.0020 in)}$$

- The valve clearance is 0.05 mm (0.0020 in) greater than specified value.
- Use a shim which is 0.05 mm (0.0020 in) thicker than the current shim to reduce the valve clearance.

② Current shim thickness (T) calculation method

- Measure the center of removed shim to determine thickness.

CAUTION:

Do not use measured shims again.

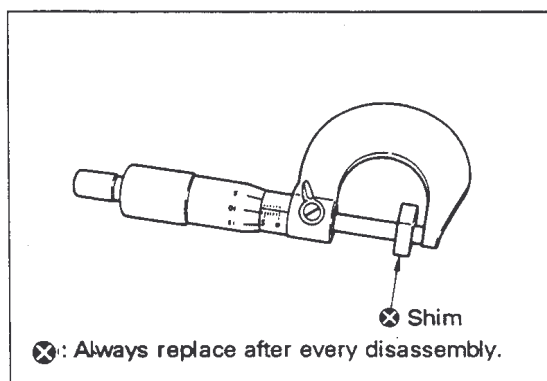

B2 RB26 DOHC EGI (ECCS) TWIN-TURBOCHARGER ENGINE

4. Valve Clearance Inspection and Adjustment (Cont'd)

③ Shim selection

- Removed shim thickness (T) is 2.40 mm (0.0945 in).
 $2.40 \text{ (T) mm (0.0945 in)} + 0.05 \text{ mm (0.0020 in)} = 2.450 \rightarrow$
selection shim thickness
- Select new shim with stamped mark $\left[\begin{smallmatrix} 24 \\ 40 \end{smallmatrix} \right]$ ($T = 2.440 - 2.455$).

CAUTION:

Select a shim which is within standard value range $\pm 0.03 \text{ mm}$ ($\pm 0.0012 \text{ in}$).

④ Shim types and classification

- There are 70 types of shims
The shim sizes range from 2.275 mm (0.0896 in) to 3.325 mm (0.1309 in) in 0.015 mm (0.0006 in) increments.
- After the camshaft is installed, measure valve clearance again and make sure clearance conforms to standard value.

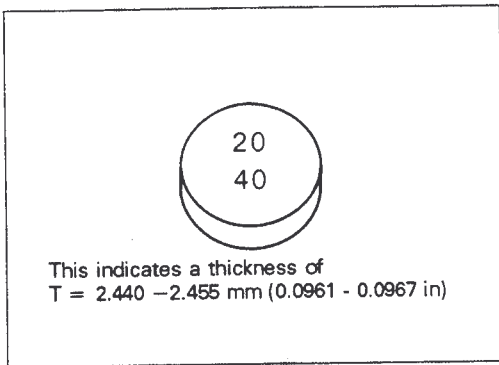

B2 RB26 DOHC EGI (ECCS) TWIN-TURBOCHARGER ENGINE

5. Lubrication System Inspection

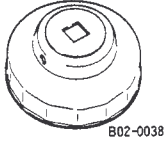
	Name	Application	
Special tool	Oil filter wrench KV101 062S0	 B02-0038	Oil filter removal and installation
Measurement tool	Oil pressure gauge		Used for oil pressure measurement

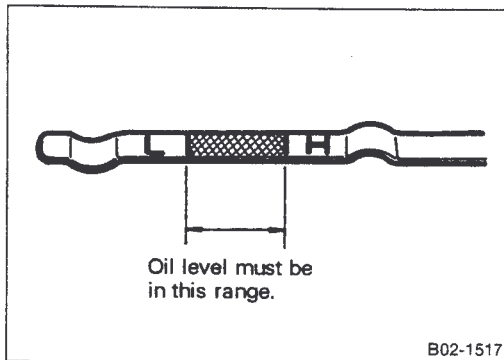

5-1 LUBRICATION OIL LEVEL INSPECTION

Inspection

- The engine oil level should be checked before starting the engine. If the engine has been started, perform the measurement ten minutes after the engine has cooled.
- The oil level should be between the H and L lines on the dipstick.
- The oil must not have any white turbidity or dirt.

Replacement interval	RB26DETT	Use SD, SE, SF or SG class oil. Change oil every 5,000 km (3,000 miles) or 6 months.
----------------------	----------	---

Note: Use genuine Nissan [Turbo X (7.5W-30)] for service.

Item	Engine	RB26DETT	
	Oil level	ℓ (Imp qt)	H
		L	3.5 (3-1/8)
Oil supplement volume when replaced	ℓ (Imp qt)	Only oil replacement	Approx. 4.2 (3-3/4)
		Oil and oil filter replacement	Approx. 4.6 (4)

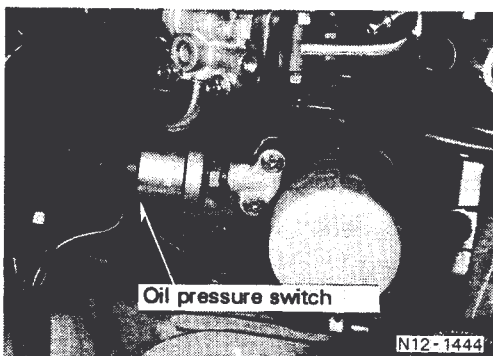

5-2 OIL PRESSURE INSPECTION

Inspection

- Remove the oil pressure switch and connect oil pressure gauge.
- After warming engine, make sure the pressure is appropriate for engine speed.

Engine speed	(rpm)	800	2,000	6,000
Outlet pressure	kPa (kg/cm ² , psi)	Approx. 147 (1.5, 21)	Approx. 294 (3, 43)	Approx. 451 (4.6, 65)

[Oil temperature: 80°C (176°F)]

B2 RB26 DOHC EGI (ECCS) TWIN-TURBOCHARGER ENGINE

5. Lubrication System Inspection (Cont'd)

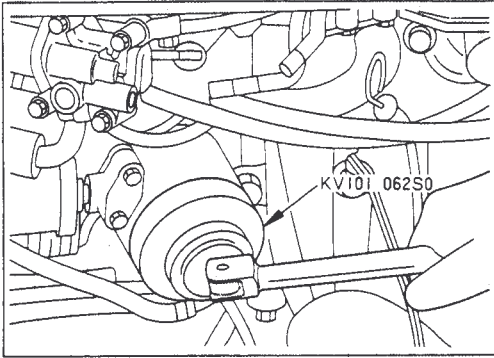

5-3 OIL FILTER REPLACEMENT

Refer to "OIL COOLER, OIL FILTER REMOVAL AND INSTALLATION" section B2, 10-15.)

Removal

- Use oil filter wrench (special service tool) to remove filter.

CAUTION:

Catch any dripping oil in a rag when removing the filter.

Installation

- Before installing new oil filter, clean the oil filter bracket mounting surface on cylinder block and coat the oil filter seal lips lightly with engine oil.
- Screw in the oil filter by hand until a slight resistance is felt and then tighten an additional 2/3 turn.

CAUTION:

Start engine and check area around drain plug and oil filter for oil leakage.

Periodic exchange interval	RB26DETT	Use SD, SE, SF or SG class oil. Change oil every 10,000 km (6,000 miles) or 1 year.
----------------------------	----------	---

6. Exhaust System Inspection

Tools required

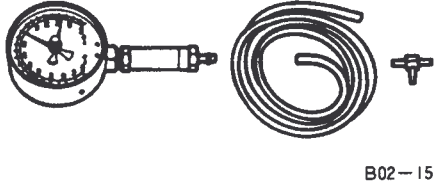
		Name	Application
Measurement tool	Compound gauge EG1508 0001	 B02-1518	Used to check turbo-charger for excess pressure.

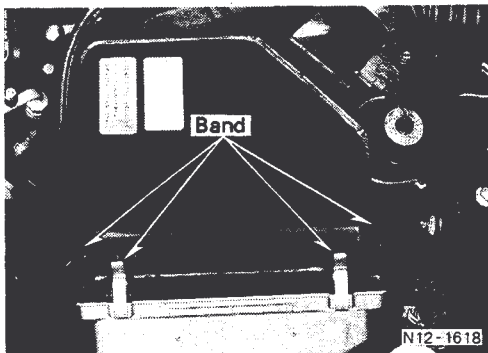

6-1 AIR CLEANER ELEMENT INSPECTION

Inspection

Remove parts from vehicle.

- Refer to Section 10-2, AIR CLEANER ELEMENT INSTALLATION.
- There should be no excessive dirt or damage in the air cleaner element.

RB26DETT	Periodic exchange interval	every 60,000 km (36,000 miles)
----------	----------------------------	--------------------------------

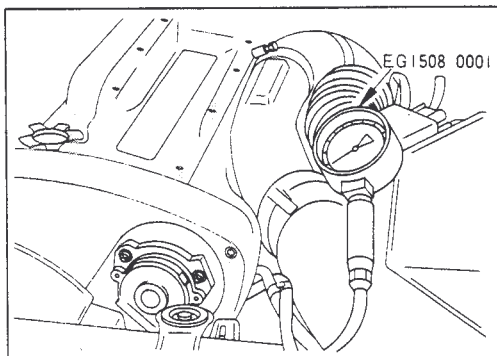

6-2 TURBOCHARGER INSPECTION

Function inspection

- Remove the intake manifold canister hose, and place a cap on the hose. Connect test hose to intake manifold and attach pressure gauge (compound gauge).
- When engine operation test is performed, check that pressure does not rise above approximately 78 to 88 kPa (0.8 to 0.9 kg/cm², 11 to 13 psi).

B2 RB26 DOHC EGI (ECCS) TWIN-TURBOCHARGER ENGINE

6. Exhaust System Inspection (Cont'd)

- a. When the pressure does not reach specified level:
 - Check for vacuum leak in intake or exhaust system or exhaust gas leak.
- b. When the pressure exceeds the maximum pressure level (approx. 78 to 88 kPa (0.8 to 0.9 kg/cm², 11 to 13 psi):
 - Check if swing valve controller rubber hose is disconnected or cut.
 - Check if swing valve controller motion malfunctions (stays closed).

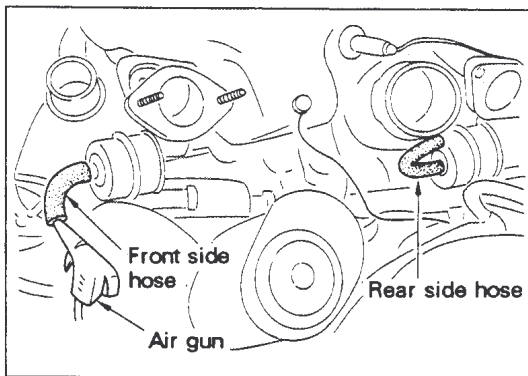

Swing valve controller inspection

- Remove the swing valve controller rubber hose from the vacuum tube side.
- When compressed air [approx. 69 to 78 kPa (0.7 to 0.8 kg/cm², 10 to 11 psi)] is forced into the hose by an air gun, the control rod must start operation. Stop blowing compressed air into the hose as soon as control rod operation is verified.

CAUTION:

The diaphragm may be damaged if excessive air pressure is applied. Use the LPG pressure gauge (special service tool for [98 kPa (1 kg/cm², 14 psi)]) to verify that the air gun pressure is approx. 78 to 88 kPa (0.8 to 0.9 kg/cm², 11 to 13 psi) before testing the air hose.

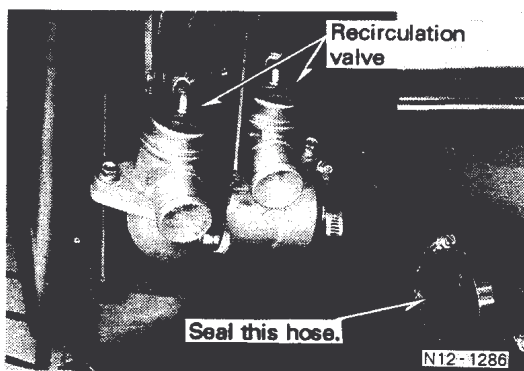

6-3 RECIRCULATION VALVE INSPECTION

Function inspection

- Remove hose on upper flow side of recirculation valve compressor (cover end of hose with cap) and check if air blows back when throttle is closed quickly.

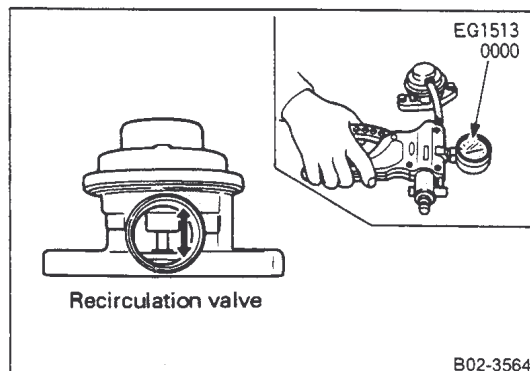

Unit inspection

- Use a hand vacuum pump to create negative pressure [-20.0 ± 4.0 kPa (-150 ± 30 mmHg, -5.91 ± 1.18 inHg)]. The recirculation valve diaphragm must start to lift and the vacuum pressure must be maintained.

B2 RB26 DOHC EGI (ECCS) TWIN-TURBOCHARGER ENGINE

7. Fuel System Inspection

Tools required

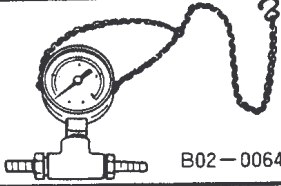
	Item	Application
Measurement tool	 EGI fuel pressure meter ST1959 0000	Fuel pressure measurement

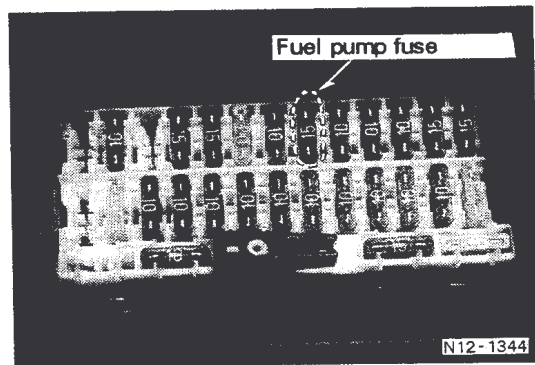

7-1 FUEL PRESSURE INSPECTION

Releasing fuel pressure

- After starting engine, remove fuel pump fuse. After the engine stops, crank the engine over two or three times and the fuel in the pipe will be consumed.
- If the engine does not start, remove the pump fuse and crank the engine three to four times to consume the fuel in fuel lines.

CAUTION:

The battery may become weak easily, so use booster cables to connect it to another vehicle or charged battery if necessary.

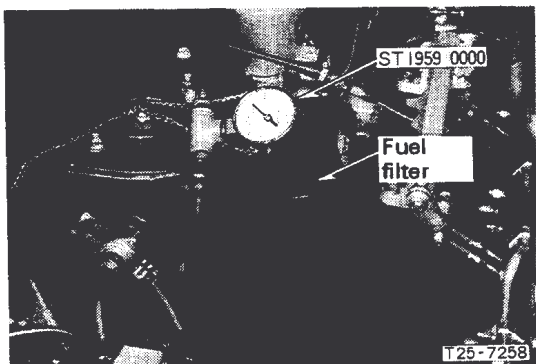

Fuel pressure meter installation

- Connect the fuel pressure meter between fuel filter and fuel line.
- Attach fuel pump fuse.

Fuel pressure inspection

- Start engine and check if the fuel pressure is standard value.
- If the engine does not start, check fuel pressure after 5 seconds when the ignition switch has been turned ON.



Fuel pressure measurement

When ignition switch is ON	kPa (kg/cm ² , psi)	Approx. 294 (3.0, 43)
During idling	kPa (kg/cm ² , psi)	Approx. 245 (2.5, 36)
Idling when pressure regulator vacuum hose is removed.	kPa (kg/cm ² , psi)	Approx. 294 (3.0, 43)

B2 RB26 DOHC EGI (ECCS) TWIN-TURBOCHARGER ENGINE

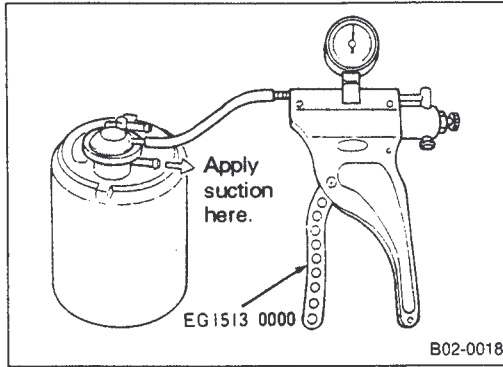

8. Evaporative Gas Control System Inspection

8-1 PURGE CONTROL VALVE INSPECTION

Inspection

- Use a hand vacuum pump to apply approximately -53.3 kPa (-400 mmHg, -15.75 inHg) and make sure vacuum pressure is maintained.
- In the preceding condition, check that a small amount of air can be sucked from the manifold vacuum path.

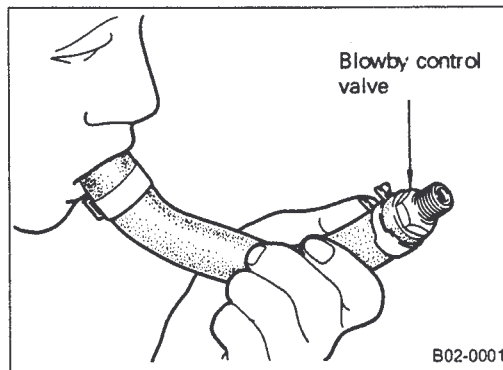

9. Blowby Gas Reduction Equipment Inspection

9-1 BLOWBY CONTROL VALVE INSPECTION

Inspection

- Check the blowby control valve flow path.

	Condition
Air is blown.	Air passes.
Air is drawn in.	No air passes.

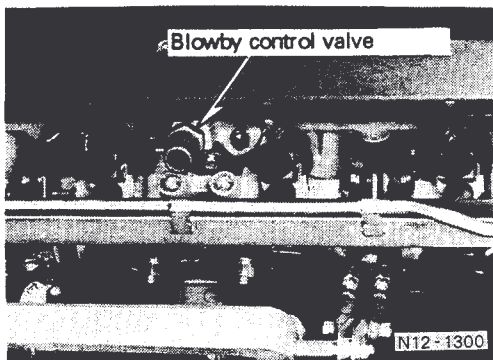

B2 RB26 DOHC EGI (ECCS) TWIN-TURBOCHARGER ENGINE

10. Removal and Installation of On-vehicle Parts

10-1 INTERCOOLER AIR DUCT ASSEMBLY

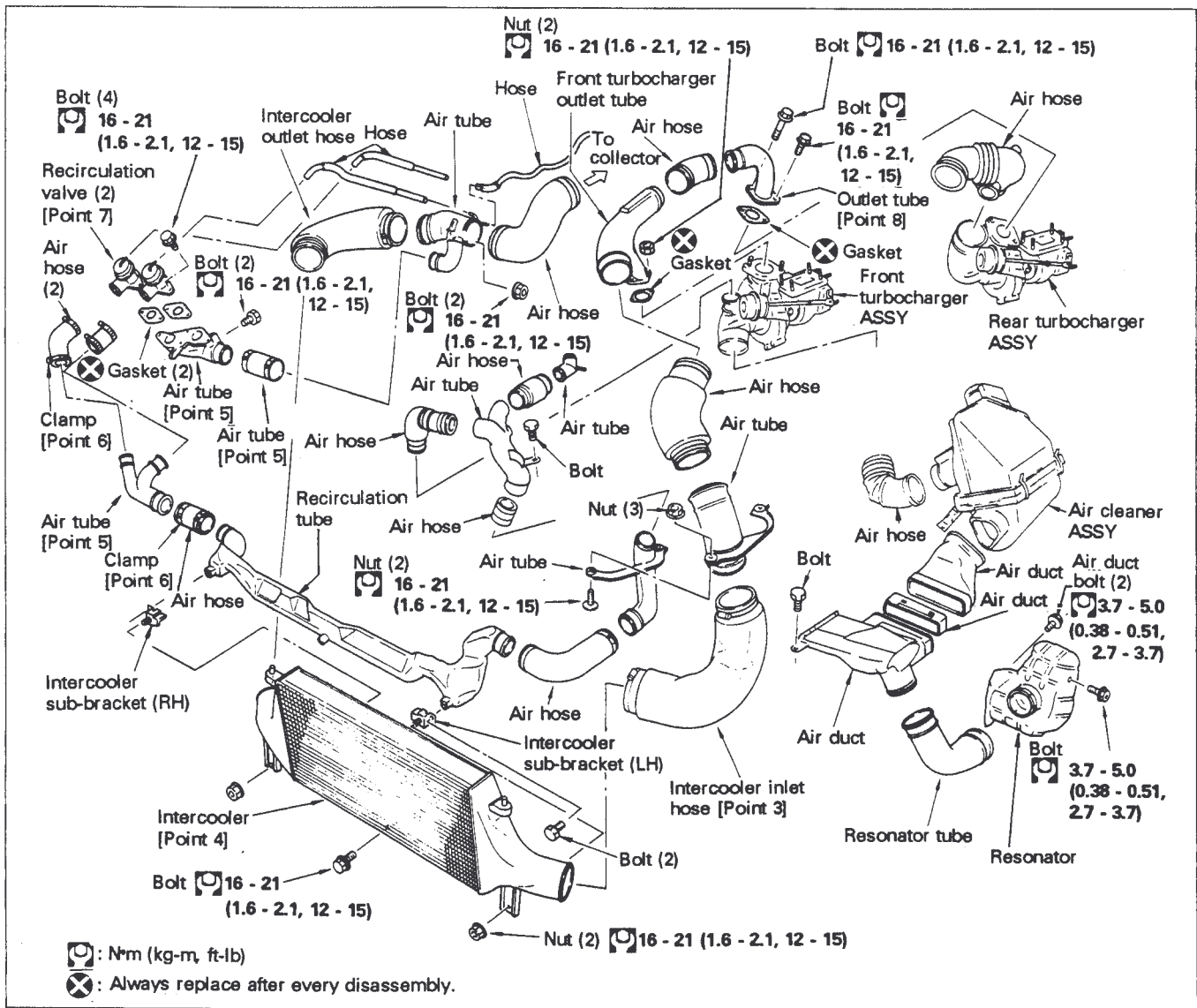

Additional work required:

Remove undercover.

Remove front bumper. (Refer to Section D1-1, Body.)

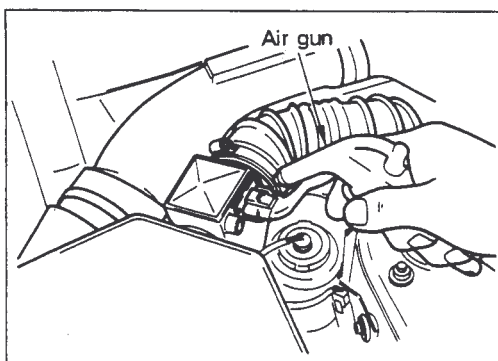

[Point 1] Air hose, air duct cleaning

- Before removing each air hose and air duct, blow off any dirt or dust with an air gun.

B2 RB26 DOHC EGI (ECCS) TWIN-TURBOCHARGER ENGINE

10. Removal and Installation of On-vehicle Parts (Cont'd)

[Point 2] Remove and install each air hose and tube.

Removal

- Draw alignment marks before removing air hoses and tubes.

Installation

- Position air hoses and tubes so the alignment marks coincide. Insert [approximately 30 mm (1.18 in)] hose or tube and tighten clamps securely.

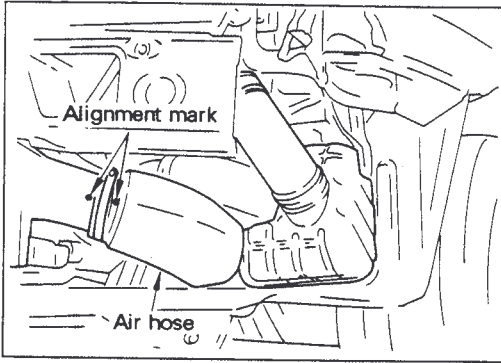

[Point 3] Remove and install the intercooler inlet hose.

Removal

- Remove the resonator and tube (B) before removing hose (A).

Installation

- Attach hose (A), then combine resonator and tube (B) as a single unit and install.

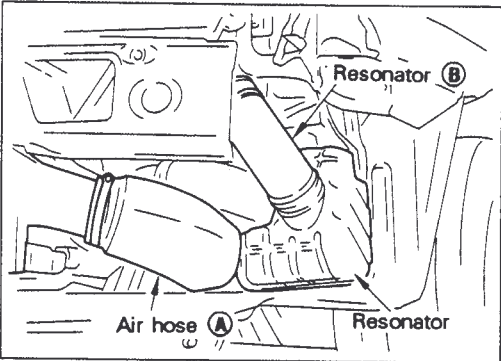

[Point 4] Remove and install intercooler.

Removal

- ① Remove the bumper finisher and bumper reinforcement. (Refer to Section D Body for details.)
- ② Separate the intercooler inlet and outlet hoses.
- ③ Remove the mounting bolt and two nuts. Detach intercooler without scratching the fins.

CAUTION:

- (1) The fins are aluminum and can be damaged easily. Never place anything on the intercooler or allow tools or other hard objects to contact the fins.
- (2) The main unit (tank, fins, tube) cannot be disassembled.

Installation

- Assembly is the reverse of disassembly. Perform steps in the sequence ③, ②, ①.

Tightening torque

9.1 - 11.8 N·m (0.93 - 1.2 kg-m, 6.7 - 8.7 ft-lb)

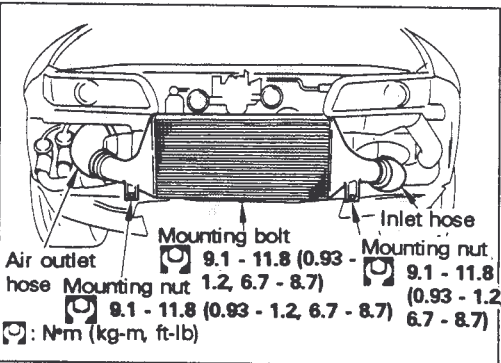

[Point 5] Recirculation hose removal and installation

- Remove and install the recirculation hose and tube as shown in the figure on the left.

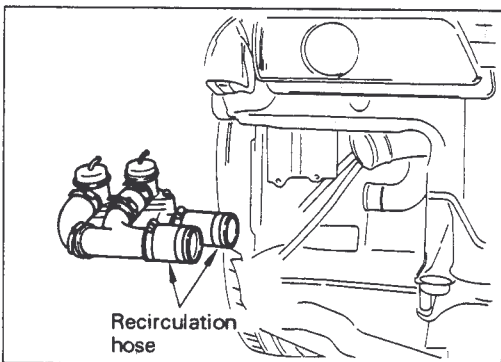

B2 RB26 DOHC EGI (ECCS) TWIN-TURBOCHARGER ENGINE

10. Removal and Installation of On-vehicle Parts (Cont'd)

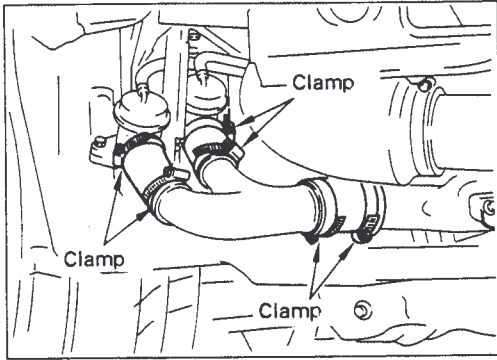

[Point 6] Recirculation hose clamp installation

- When the recirculation hose clamp is installed, it must not contact the bumper finisher.

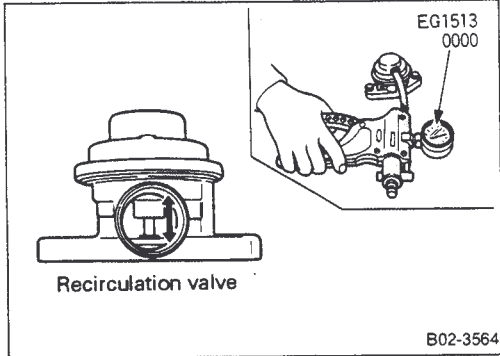

[Point 7] Recirculation valve inspection

Unit inspection

- Use a hand vacuum pump to apply a vacuum [-20.0 ± 2.7 kPa (-150 ± 20 mmHg, -5.91 ± 0.79 inHg)] and check that recirculation valve diaphragm lifts and vacuum pressure is maintained.

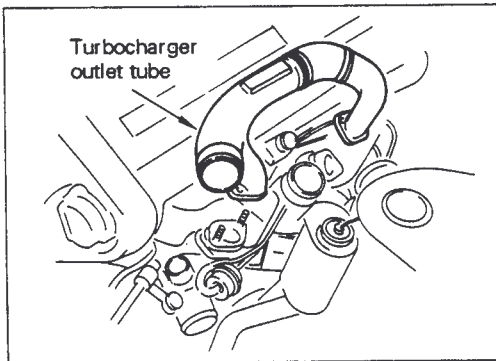

[Point 8] Turbocharger outlet tube removal and installation

- Remove and install turbocharger outlet tube as shown in figure on left.

10-2 AIR CLEANER ELEMENT

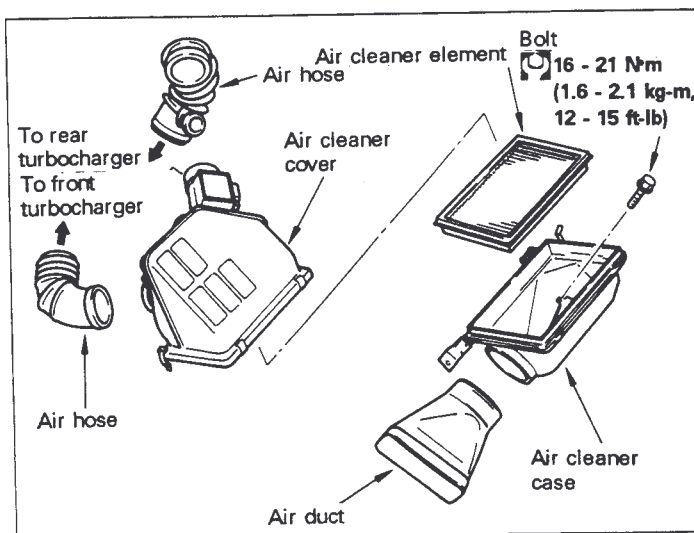

Additional work required:

Remove turbocharger outlet hose. [Point 2]

B2 RB26 DOHC EGI (ECCS) TWIN-TURBOCHARGER ENGINE

10. Removal and Installation of On-vehicle Parts (Cont'd)

[Point 1] Air hose and air duct cleaning

- Use an air gun to blow off any dirt or dust before removing the air cleaner element.

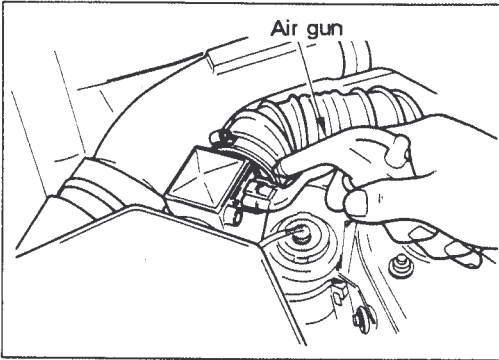

[Point 2] Air cleaner element removal and installation

Removal

- ① Remove turbocharger outlet hose.

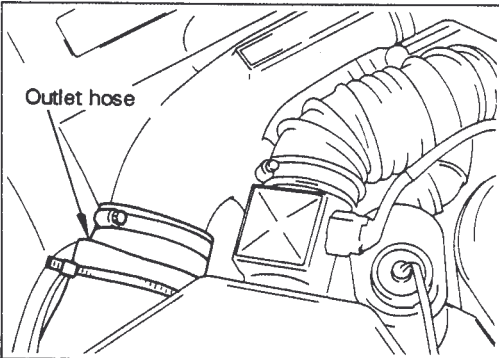

- ② Remove the four band clips from air cleaner. Lift air cleaner cover and remove air cleaner element.

Installation

- Install in reverse order of removal.

[Point 3] Air cleaner element inspection

- Air cleaner element must not be dirty or damaged.

Periodic replacement interval:

Every 60,000 km (36,000 miles)

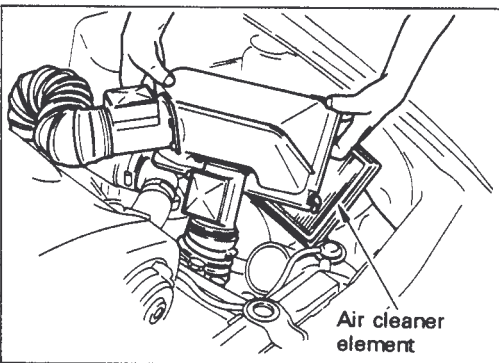

[Point 4] Air cleaner cover installation

- First connect air flow meter connector for front turbocharger and then install air cleaner cover.

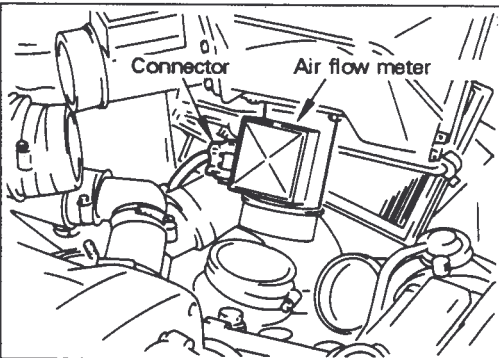

B2 RB26 DOHC EGI (ECCS) TWIN-TURBOCHARGER ENGINE

10. Removal and Installation of On-vehicle Parts (Cont'd)

10-3 COLLECTOR ASSY

(1) Collector ASSY removal and installation

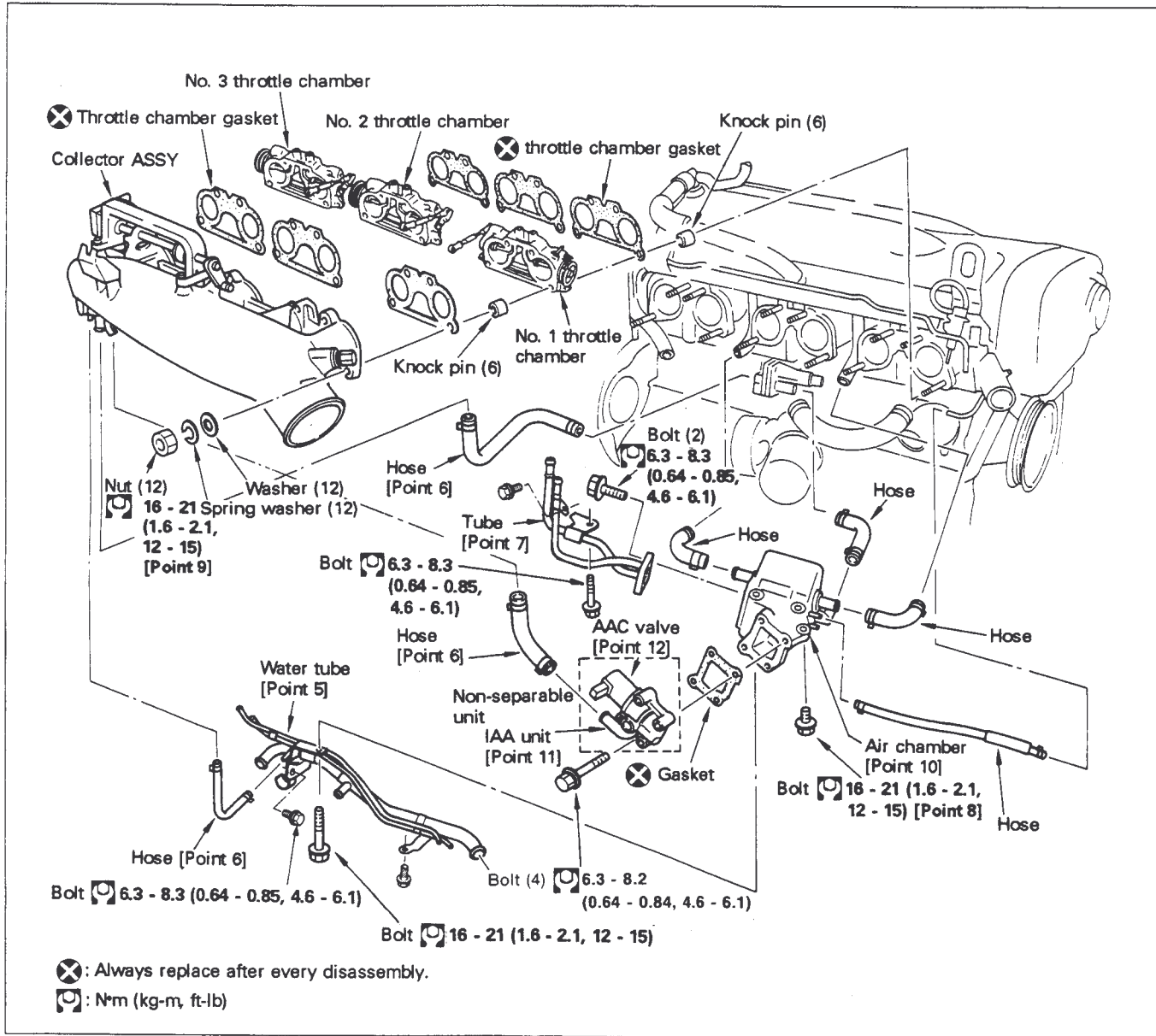

Additional work required

- Drain and refill cooling water. [Point 2]
- Release fuel pressure in the fuel lines. [Point 1]
- Acceleration control wire [Point 3]
- Air inlet hose
- EGI harness connector, harness clamp
- All hoses

B2 RB26 DOHC EGI (ECCS) TWIN-TURBOCHARGER ENGINE

10. Removal and Installation of On-vehicle Parts (Cont'd)

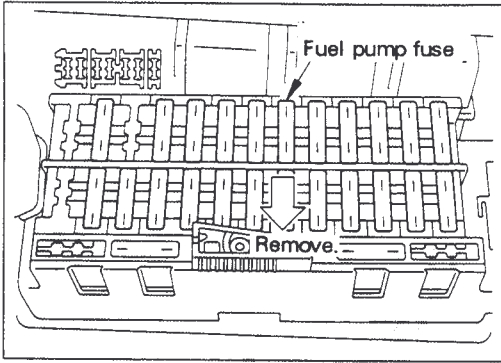

[Point 1] Release fuel pressure

- Start the engine.
- After engine starts, remove fuel pump fuse and wait until engine stops. Crank engine two or three times to use up fuel remaining in fuel lines.
- If the vehicle will not start, remove the fuel pump fuse, crank the engine 4 to 5 times to use up fuel in fuel lines.

CAUTION:

Connect the battery with booster cables to a battery in another vehicle or charged battery since the battery may drain easily.

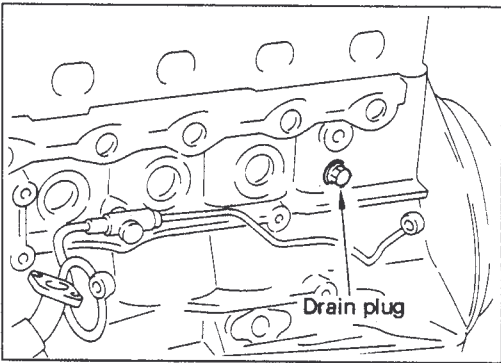

[Point 2] Drain the cooling water.

- Remove drain plug from cylinder block to drain all coolant from block.

CAUTION:

Make sure coolant does not fall on front exhaust pipe.

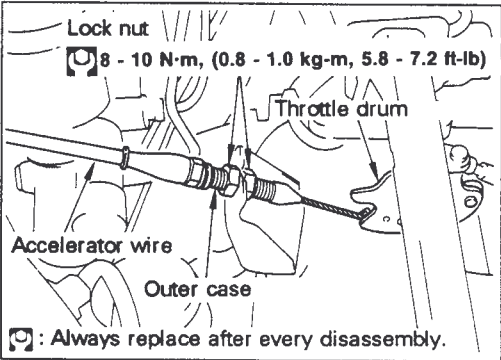

[Point 3] Accelerator wire adjustment

- Loosen lock nut to provide adequate slack for the accelerator wire and pull outer case in the direction of the accelerator. Return lock nut 1.0 to 1.5 turns from the position the throttle drum starts moving (when there is no play in cable) and tighten.

Tightening torque:

8 - 10 N·m (0.8 - 1.0 kg-m, 5.8 - 7.2 ft-lb)

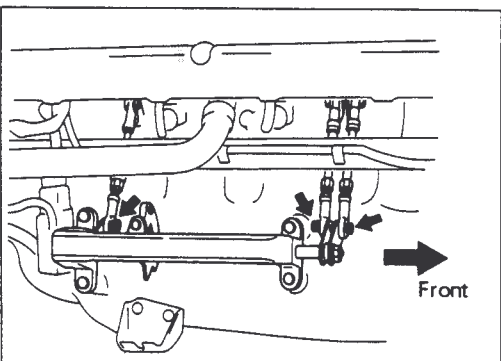

[Point 4] Remove throttle chamber linkage.

- Remove mounting nuts indicated by arrow marks. Separate the three throttle chamber links from collector side.
- Remove harness from throttle sensor and throttle valve switch.

B2 RB26 DOHC EGI (ECCS) TWIN-TURBOCHARGER ENGINE

10. Removal and Installation of On-vehicle Parts (Cont'd)

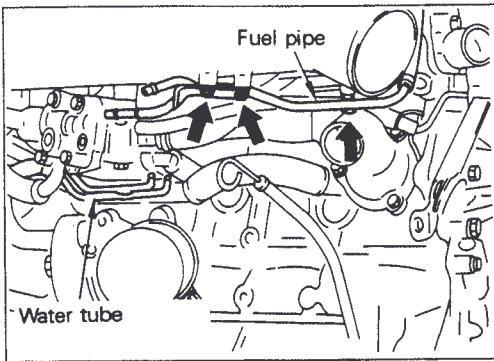

[Point 5] Fuel pipe removal

- Remove the three bolts indicated by the arrows and separate the fuel pipe.

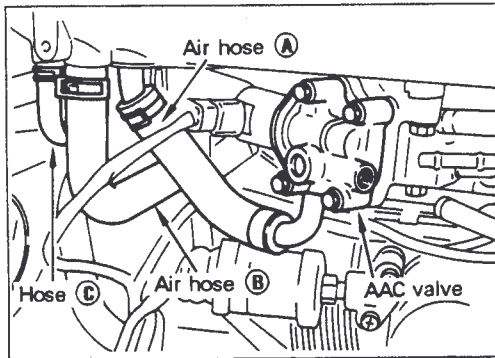

[Point 6] Air hose removal

- Separate air hoses (A), (B) and (C) from the collector side.

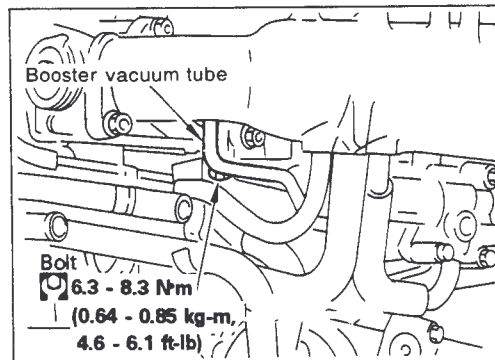

[Point 7] Booster vacuum tube removal

- Remove the clamp bolts, separate booster vacuum tube from collector and air chamber and remove tube.

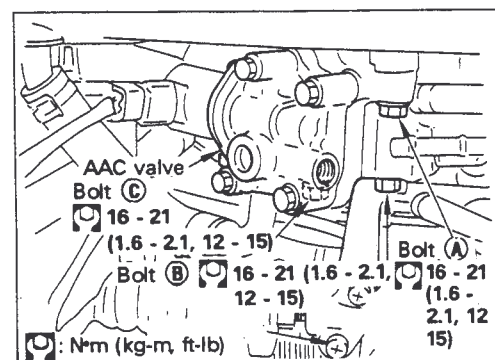

[Point 8] Air chamber bolts removal and installation

Removal

- Remove the three bolts and separate air chamber.

Installation

- Insert bolt (B) in air chamber bolt hole, before performing final assembly.

Tightening torque:

16 - 21 N·m (1.6 - 2.1 kg-m, 12 - 15 ft-lb)

[Point 9] Collector nut removal and installation

Removal

- Remove the nuts in the reverse order of the figure on the left.

Installation

- Tighten nuts in order shown in figure on left uniformly in two to three stages.

Tightening torque:

16 - 21 N·m (1.6 - 2.1 kg-m, 12 - 15 ft-lb)

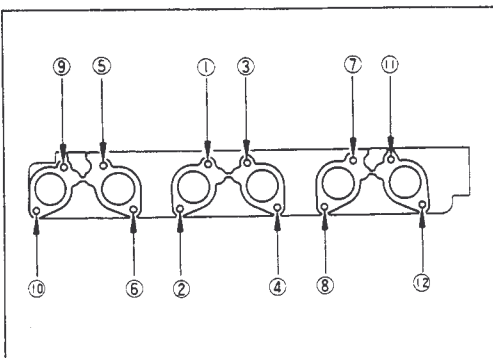

B2 RB26 DOHC EGI (ECCS) TWIN-TURBOCHARGER ENGINE

10. Removal and Installation of On-vehicle Parts (Cont'd)

[Point 10] Air chamber removal and installation

Removal

- Separate air hoses **A**, **B**, **C**, vacuum hoses **D**, **F** and AAC valve connector and remove air chamber.

Installation

- Position air chamber in place, connect air hoses **C**, **B**, **A**, vacuum hoses **F**, **E**, then connect AAC valve connector.

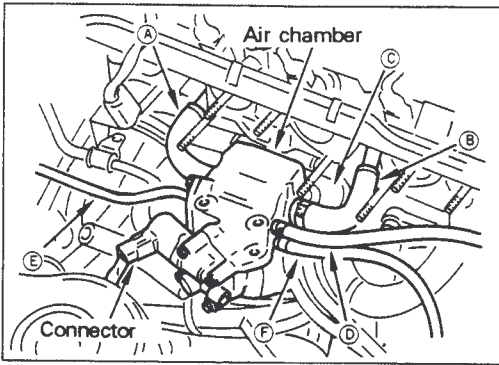

[Point 11] AAC valve removal and installation

Removal

- Remove the four bolts and detach AAC valve.

CAUTION:

- (1) The AAC valve cannot be disassembled.
- (2) Replace gasket with a new one.

Installation

- Install gasket and AAC valve.

Tightening torque:

6.3 - 8.3 N·m (0.64 - 0.85 kg-m, 4.6 - 6.1 ft-lb)

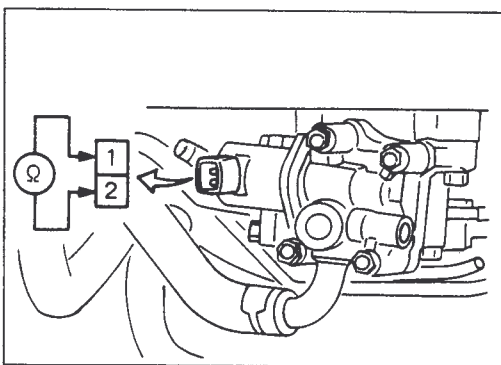
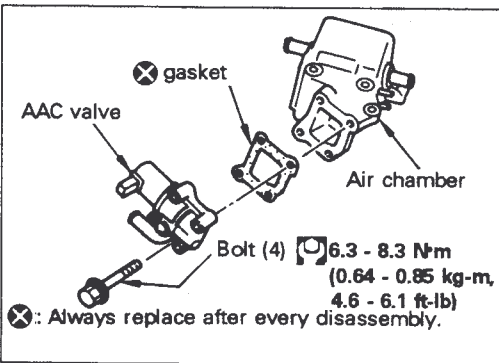

[Point 12] AAC valve inspection

- Measure the AAC valve resistance.

Resistance [20°C (68°F)]:

Approx. 9 - 10 (Ω)

B2 RB26 DOHC EGI (ECCS) TWIN-TURBOCHARGER ENGINE

10. Removal and Installation of On-vehicle Parts (Cont'd)

(2) Collector ASSY disassembly and assembly

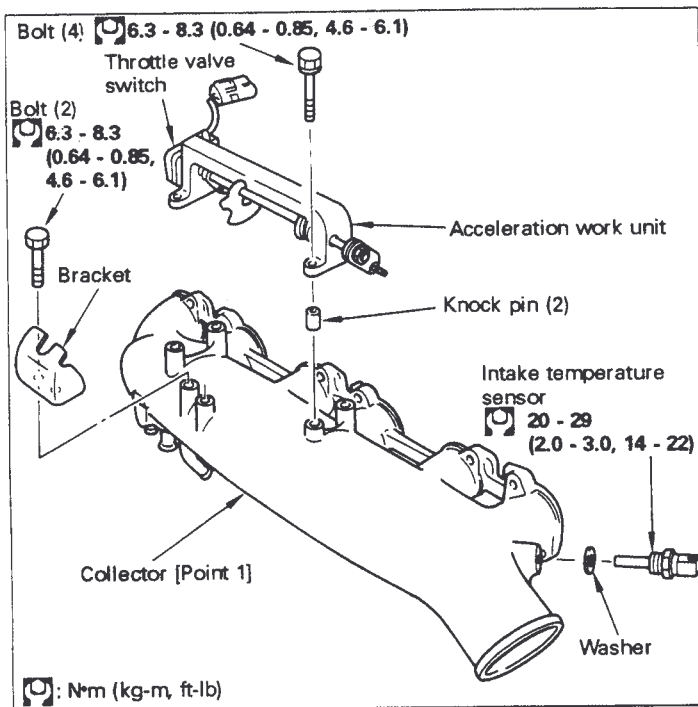

Additional work required:

- **Collector ASSY installation**
Refer to Section B3, 6-3, THROTTLE VALVE SWITCH SYSTEM INSPECTION for the throttle valve switch adjustment procedures. Refer to section B2, 10-5, 6 IN-LINE THROTTLE CHAMBER LINKAGE ADJUSTMENT for the related adjustment procedures.

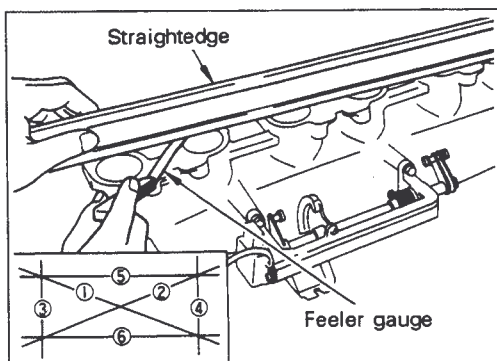

[Point 1] Collector installation

- Measure the collector installation surface for distortion in six directions (opposing directions, up, down, left, right, horizontally and vertically).
Limit: 0.15 mm (0.0059 in)

B2 RB26 DOHC EGI (ECCS) TWIN-TURBOCHARGER ENGINE

10. Removal and Installation of On-vehicle Parts (Cont'd)

10-4 6 IN-LINE THROTTLE CHAMBER REMOVAL AND INSTALLATION

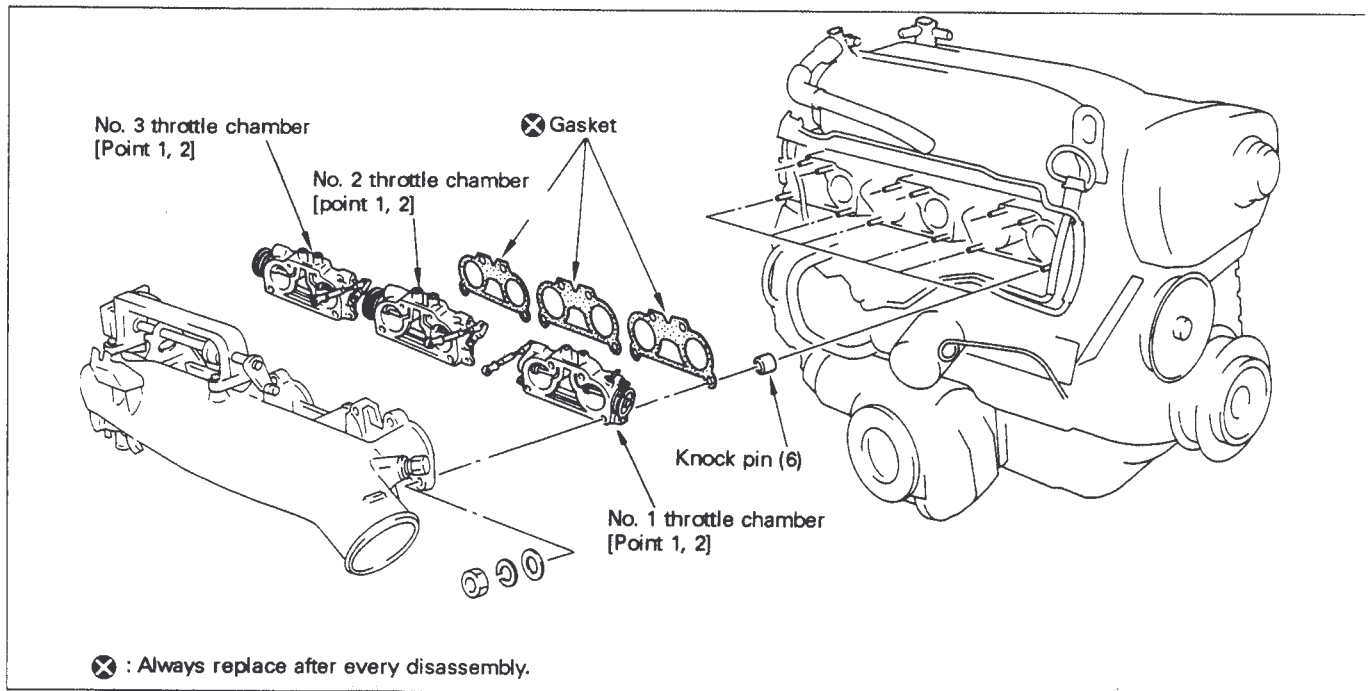

Additional work required:

- Collector ASSY removal and installation
- Canister hose

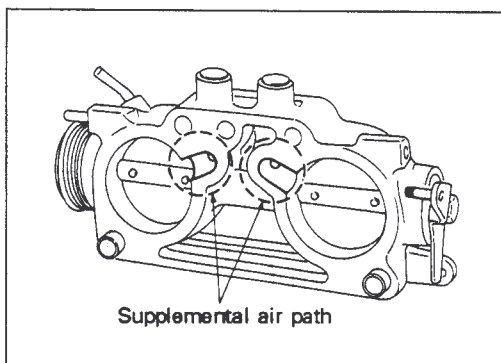

[Point 1] Throttle chamber inspection

- Check that there are no cracks and that supplemental air paths are not obstructed.

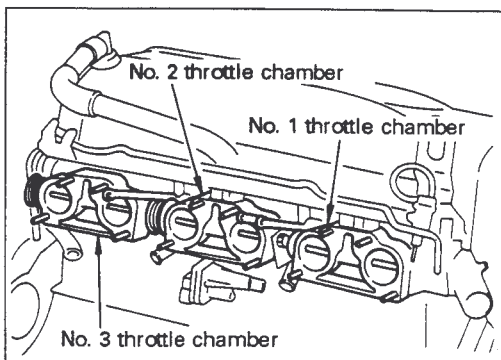

[Point 2] Throttle chamber installation

- Install the No. 1 to No. 3 throttle chambers.

CAUTION:

Do not make any mistake when installing the chamber.

B2 RB26 DOHC EGI (ECCS) TWIN-TURBOCHARGER ENGINE

10. Removal and Installation of On-vehicle Parts (Cont'd)

10-5 6 IN-LINE THROTTLE CHAMBER LINKAGE ADJUSTMENT

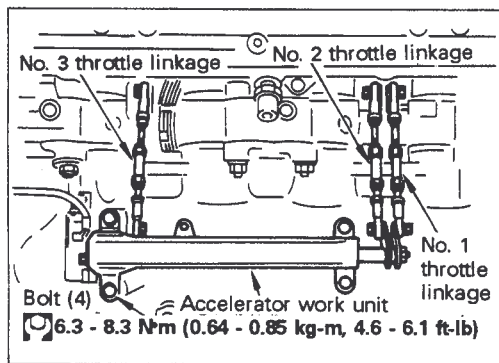
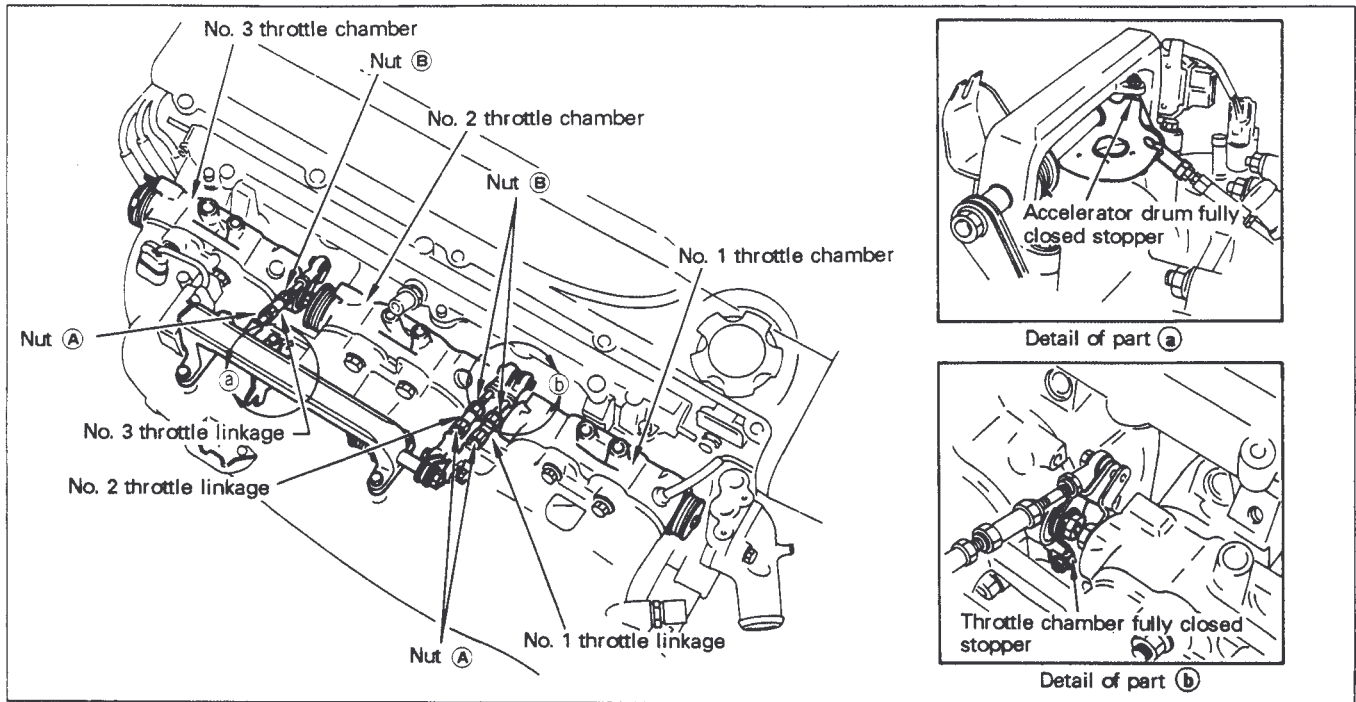

[Point 1] Accelerator work unit installation

- Install the 6 in-line throttle chamber and accelerator work unit and connect the No. 1, 2 and 3 throttle linkages.

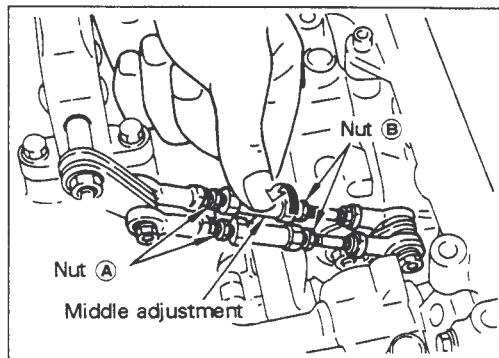

[Point 2] 6 in-line throttle chamber linkage adjustment

- ① Loosen nuts A and B for each throttle linkage. Turn the middle adjustment of each throttle linkage counterclockwise to shorten the linkage.

B2 RB26 DOHC EGI (ECCS) TWIN-TURBOCHARGER ENGINE

10. Removal and Installation of On-vehicle Parts (Cont'd)

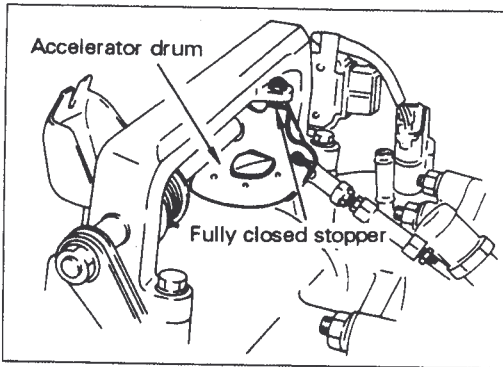

- ② Shorten each throttle linkage until acceleration drum contacts fully closed stopper on the accelerator work unit side.

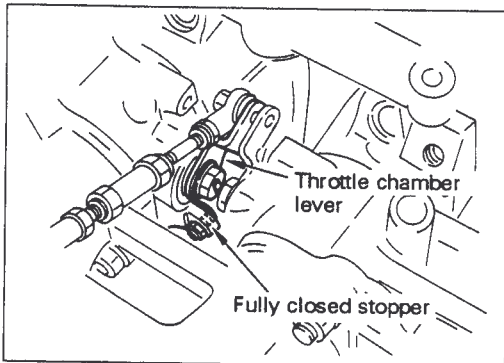

- ③ Shorten each throttle linkage, so the throttle chamber lever opens wider than fully closed stopper on the throttle chamber side.

CAUTION:

1. Do not lock nuts **A** and **B**.
2. The throttle chamber lever opening angle should be adequate.

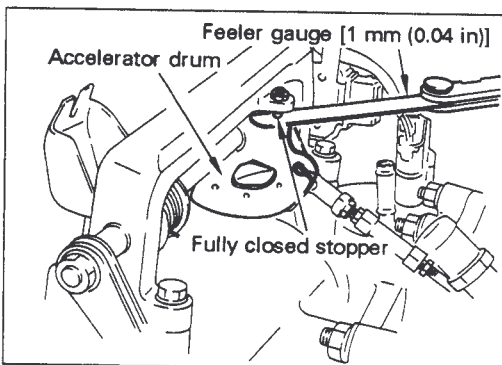

- ④ Insert a 1 mm (0.04 in) feeler gauge between the accelerator drum and fully closed stopper on the accelerator work unit side.
Secure accelerator drum so it does not move.

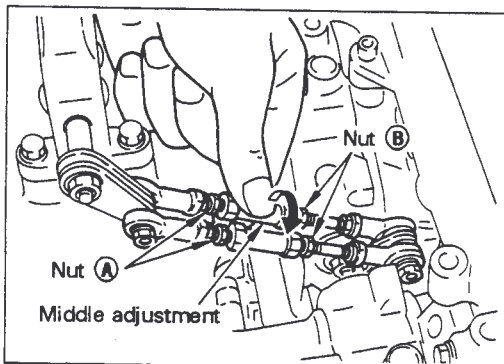

- ⑤ With feeler gauge inserted, turn the middle adjustment in No. 2 throttle linkage clockwise to lengthen throttle linkage until the throttle chamber lever contacts the fully closed stopper on the throttle chamber side.

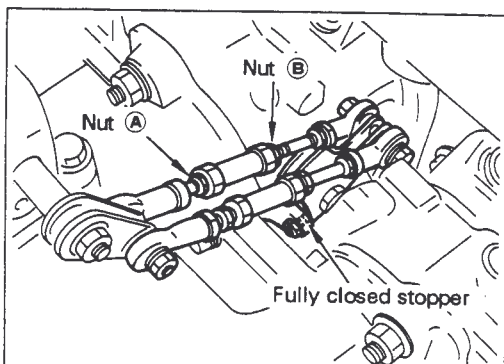

- ⑥ When the fully closed stopper contacts, the throttle chamber lever, you should feel resistance when turning the throttle linkage with your fingers. Shorten the throttle linkage to the point just before this resistance is felt.

B2 RB26 DOHC EGI (ECCS) TWIN-TURBOCHARGER ENGINE

10. Removal and Installation of On-vehicle Parts (Cont'd)

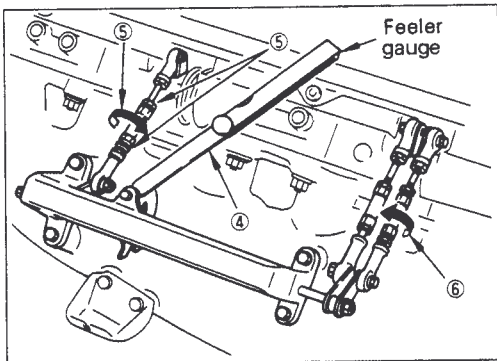

- ⑦ Perform steps ④, ⑤ and ⑥ to adjust the No. 3 and 1 throttle linkages.

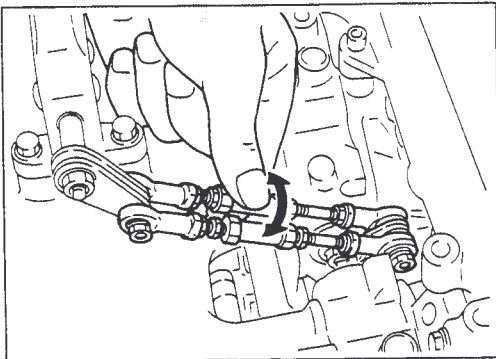

- ⑧ After the adjustment is completed for the three throttle linkages, tighten lock nuts **A** and **B**. After the nuts are tightened, No. 1 - 3 throttle linkages must turn with same degree of smoothness.

CAUTION:

The middle adjustment linkage must not turn when the lock nut is tightened.

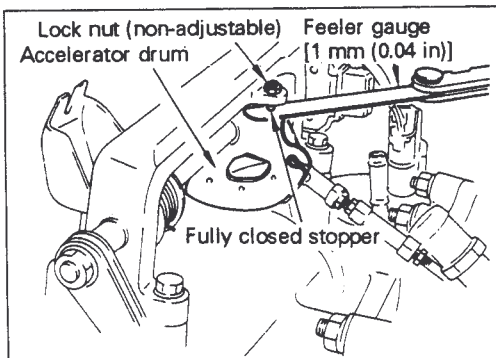

- ⑨ Remove feeler gauge from fully closed stopper on accelerator work unit side.

CAUTION:

Do not adjust fully closed stopper nut.

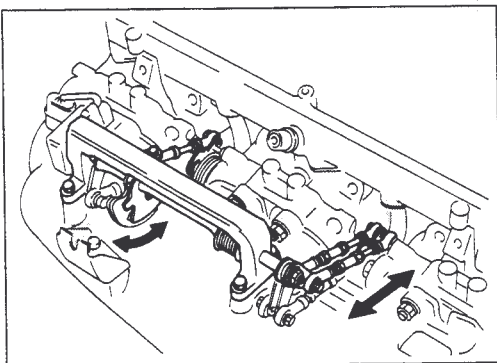

- ⑩ Completely open and close the 6 in-line throttle chambers repeatedly and check that each throttle chamber moves smoothly.

B2 RB26 DOHC EGI (ECCS) TWIN-TURBOCHARGER ENGINE

10. Removal and Installation of On-vehicle Parts (Cont'd)

10-6 INTAKE MANIFOLD ASSY

Tools required

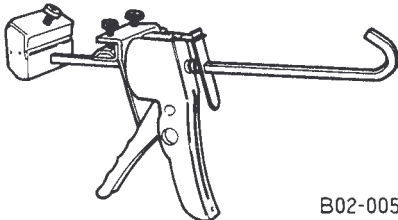
	Name	Application	
Tool	Tube presser WS3993	 B02-0051	Liquid gasket lubrication

B2 RB26 DOHC EGI (ECCS) TWIN-TURBOCHARGER ENGINE

10. Removal and Installation of On-vehicle Parts (Cont'd)

(1) Intake Manifold ASSY Removal and Installation

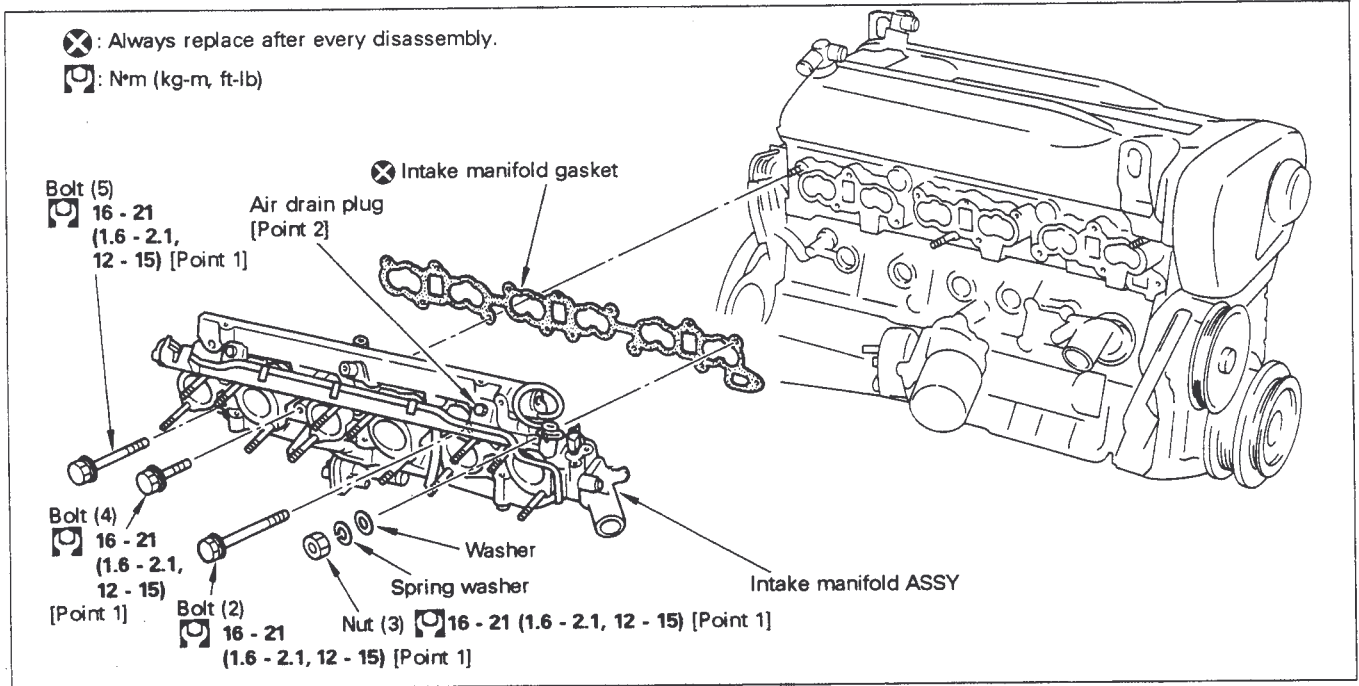

Additional work required:
Removal and Installation

- Collector ASSY
- Throttle chamber
- ECCS harness connector and all hoses
- Water outlet hose
- Blowby hose

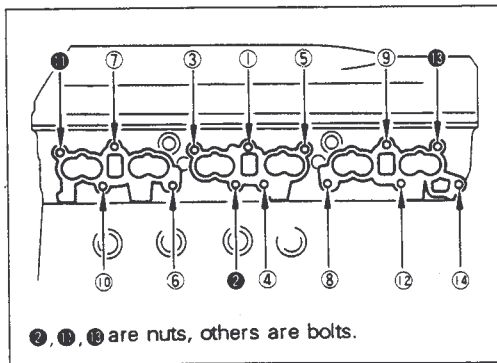

[Point 1] Intake manifold ASSY bolt and nut removal and installation

Removal

- Removal is the reverse of order shown in the figure on left.

Installation

- Installation is performed in order shown in figure. Tighten in gradual steps to uniform tightness.

	Length: Number of bolts	Installation location
Bolt length below head mm (in)	30 (1.18): (4)	③, ⑤, ⑥, ⑧
	60 (2.36): (5)	①, ④, ⑩, ⑫, ⑭
	65 (2.56): (6)	⑦, ⑨

Tightening torque:

16 - 21 N·m (1.6 - 2.1 kg-m, 12 - 15 ft-lb)

B2 RB26 DOHC EGI (ECCS) TWIN-TURBOCHARGER ENGINE

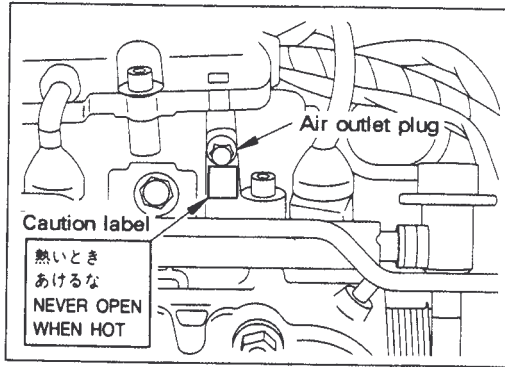

10. Removal and Installation of On-vehicle Part (Cont'd)

[Point 2] Air drain plug

Refer to section B6, 3, for details.

- Perform when engine is cool.

WARNING:

Never remove the air drain plug when engine is warm, because hot water may escape and cause injury.

- When pouring coolant into engine, always remove air drain plug to allow air within engine to escape. (This prevents overheating.)

CAUTION:

Be careful not to strip screw threads by over-torquing the air drain plug.

Tightening torque:

7 - 8 N·m (0.7 - 0.8 kg-m, 5.1 - 5.8 ft-lb)

B2 RB26 DOHC EGI (ECCS) TWIN-TURBOCHARGER ENGINE

10. Removal and Installation of On-vehicle Parts (Cont'd)

(2) Intake manifold ASSY disassembly and assembly

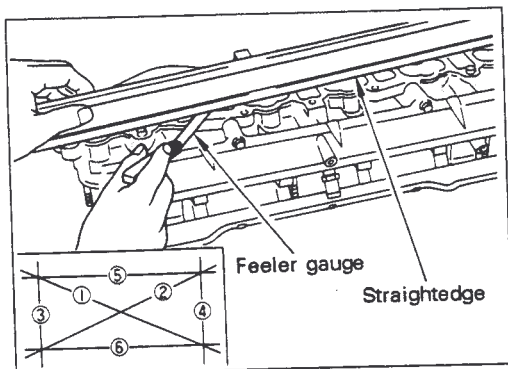
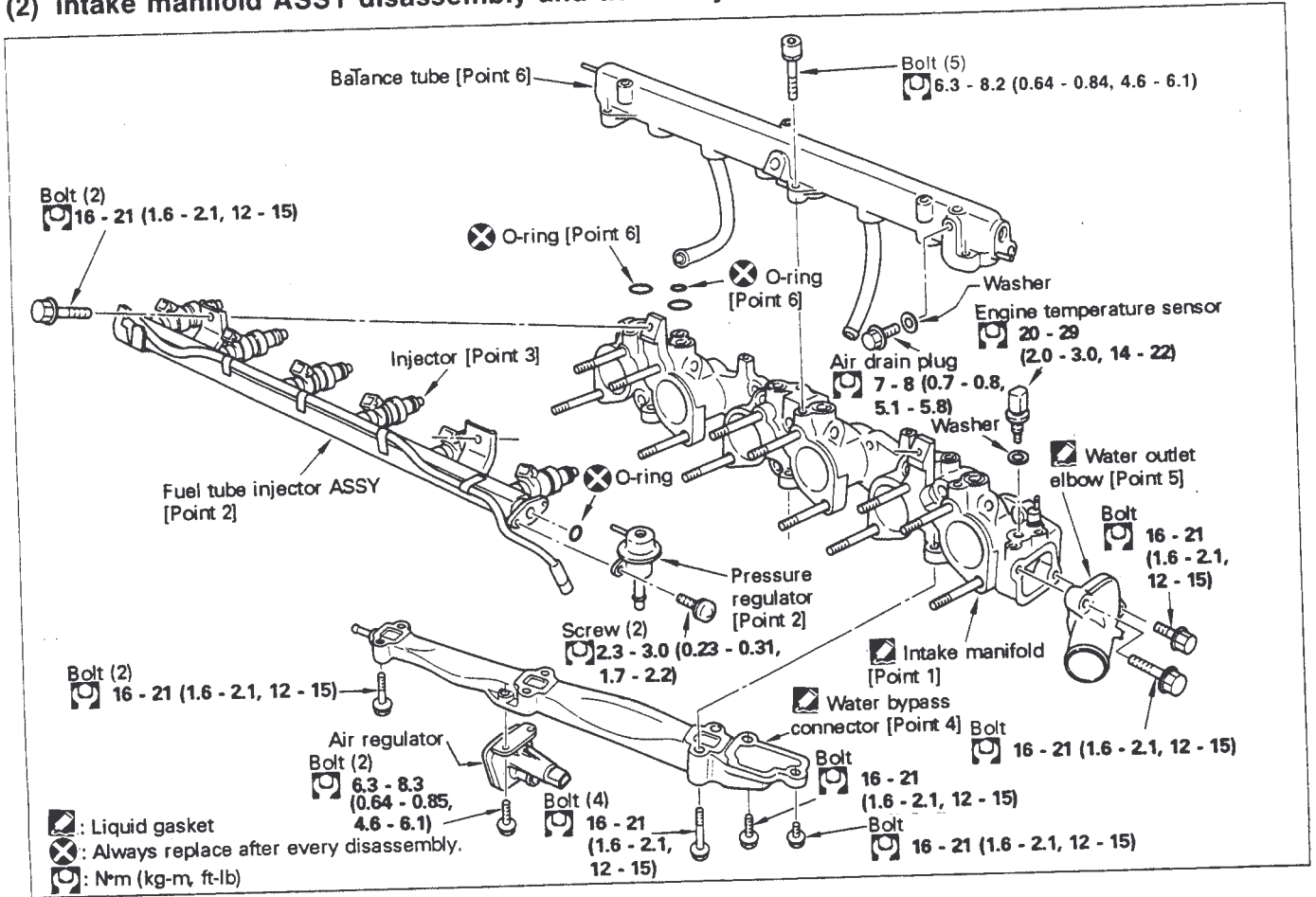

[Point 1] Intake manifold inspection

- Measure the intake manifold surface for distortions in six separate directions (at opposite directions; up, down, right, left, horizontally and vertically) in a number of locations.

Limit:

0.15 mm (0.0059 in)

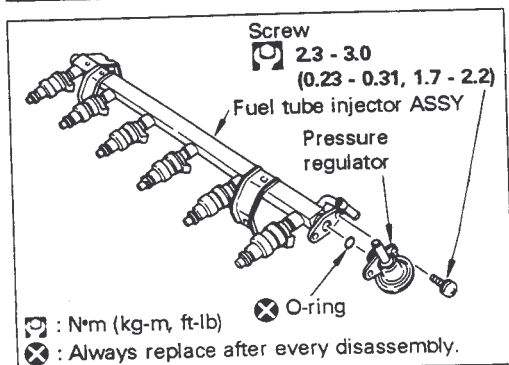

[Point 2] Fuel tube ASSY

- O-rings must be replaced with new ones when pressure regulator is removed and installed.

CAUTION:

When pressure regulator is installed, be careful not to scratch the surfaces which contact O-rings.

B2 RB26 DOHC EGI (ECCS) TWIN-TURBOCHARGER ENGINE

10. Removal and Installation of On-vehicle Parts (Cont'd)

[Point 3] O-rings (for fuel injector pressure regulator)

Installation precautions

- Never re-use O-rings.
- Coat O-rings with engine oil (10W-30 or equivalent) or silicon oil (NUC silicon L45 or equivalent) but do not apply solvent to them as this may remove the oil coating.
- Do not allow dirt, dust or foreign matter to adhere to O-rings or other equipment surfaces. Do not use dirty O-rings.
- Be careful when installing O-rings so tools or operator's fingernails do not make scratches, twist or stretch them. In particular, do not insert them in the fuel tube by making them stretch slightly.
- When inserting the fuel injectors and pressure regulator in the fuel tubes, be careful not to install them off-center or rotate them.
- Do not store O-rings in locations subject to ozone, high temperatures or direct sunlight.

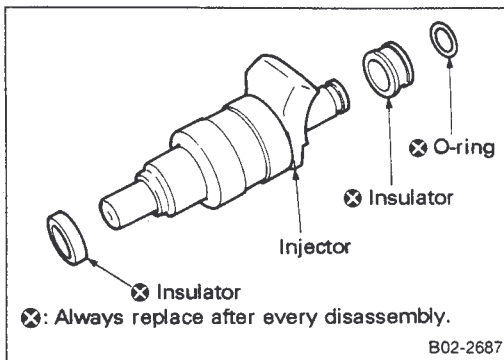

[Point 4] Water bypass connector removal and installation

Removal and cleaning

- Remove the eight water bypass connector bolts. Insert screwdriver in clearance between the intake manifold and water bypass connector and move it lightly to remove connector.
- Use a scraper and remove liquid gasket.

CAUTION:

Liquid gasket in grooves must also be removed.

- Wipe off the surface with white gasoline, etc.

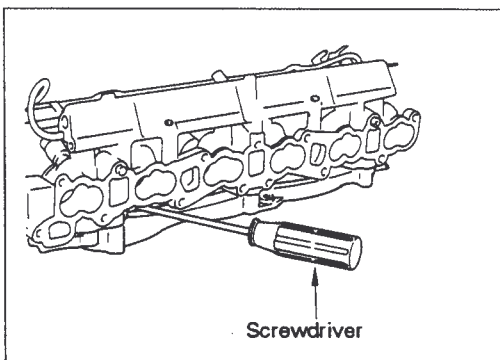

Installation

- Cut nozzle end of liquid gasket (KP510 00150) in position shown in left figure. Use a tube presser to apply gasket.

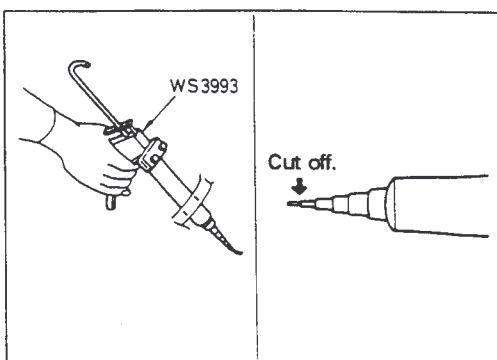

B2 RB26 DOHC EGI (ECCS) TWIN-TURBOCHARGER ENGINE

10. Removal and Installation of On-vehicle Parts (Cont'd)

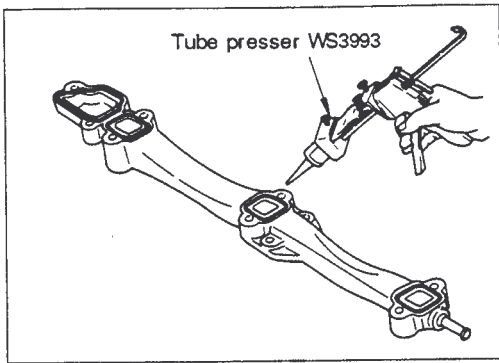

Installation

- Apply the liquid gasket (KP510 00510) to water bypass connector surfaces in four locations at one time without stopping, then install water bypass connector within 20 minutes.

CAUTION:

- (1) Apply liquid gasket coating 3.0 mm (0.118 in) wide (target width).
- (2) Coat on the inside of installation holes as shown.

Tightening torque:

16 - 21 N·m (1.6 - 2.1 kg-m, 12 - 15 ft-lb)

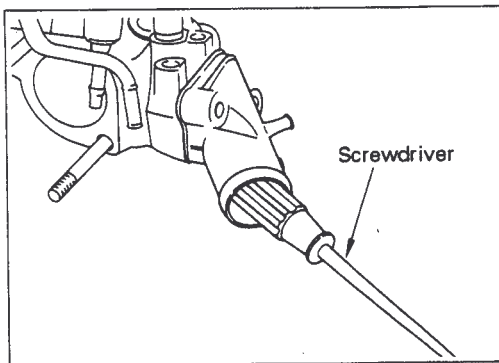

[Point 5] Water outlet elbow

Removal and cleaning

- Remove the two water outlet elbow mounting bolts. Insert screwdriver handle as shown, and move it up and down to remove elbow.
- Use a scraper to remove liquid gasket from intake manifold and water outlet elbow.

CAUTION:

Liquid gasket in grooves must also be removed.

- Wipe off the installation surface with white gasoline, etc.

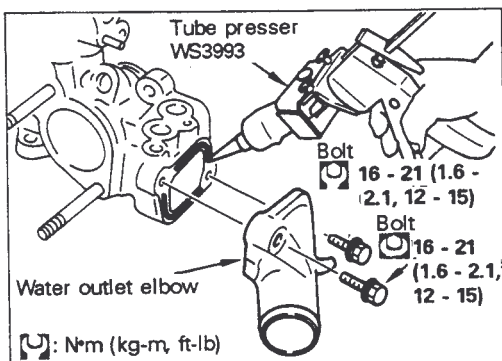

Installation

- Cut nozzle end of liquid gasket (KP510 00150). Use a tube presser to apply gasket.
- Apply the liquid gasket (KP510 00510) to intake manifold at one time without stopping as shown in figure on left.
- Complete installation within 20 minutes after liquid gasket application.

CAUTION:

Apply liquid gasket coating 3.0 mm (0.118 in) wide.

Tightening torque:

16 - 21 N·m (1.6 - 2.1 kg-m, 12 - 15 ft-lb)

[Point 6] Balance tube removal and installation

Removal

- When removing balance tube, check O-ring size.

Installation

- When installing balance tube, replace O-rings with new ones.
- There are three different O-ring sizes. Be careful to install the correct size.

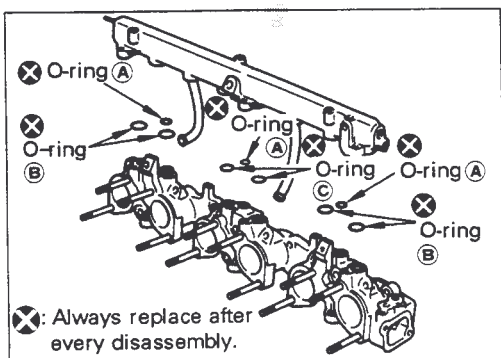

B2 RB26 DOHC EGI (ECCS) TWIN-TURBOCHARGER ENGINE

10. Removal and Installation of On-vehicle Parts (Cont'd)

	Number of unit	Installation location
O-ring A (small)	3 locations	Cylinders 1, 2, 3, 4, 5, 6
O-ring B (large)	4 locations	Cylinders 1, 2, 5, 6
O-ring C (medium)	2 locations	Cylinders 3, 4

- Be careful not to pinch the O-rings during installation.

B2 RB26 DOHC EGI (ECCS) TWIN-TURBOCHARGER ENGINE

10. Removal and Installation of On-vehicle Parts (Cont'd)

10-7 TURBOCHARGER ASSY

Tools required

	Name	Application
Measurement tool	Compound gauge EG1508 0001	Turbocharged pressure control inspection
	Dial gauge	Turbocharger rotor shaft inspection

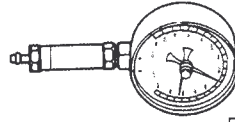

B02-1948

(1) Turbocharger ASSY removal and installation

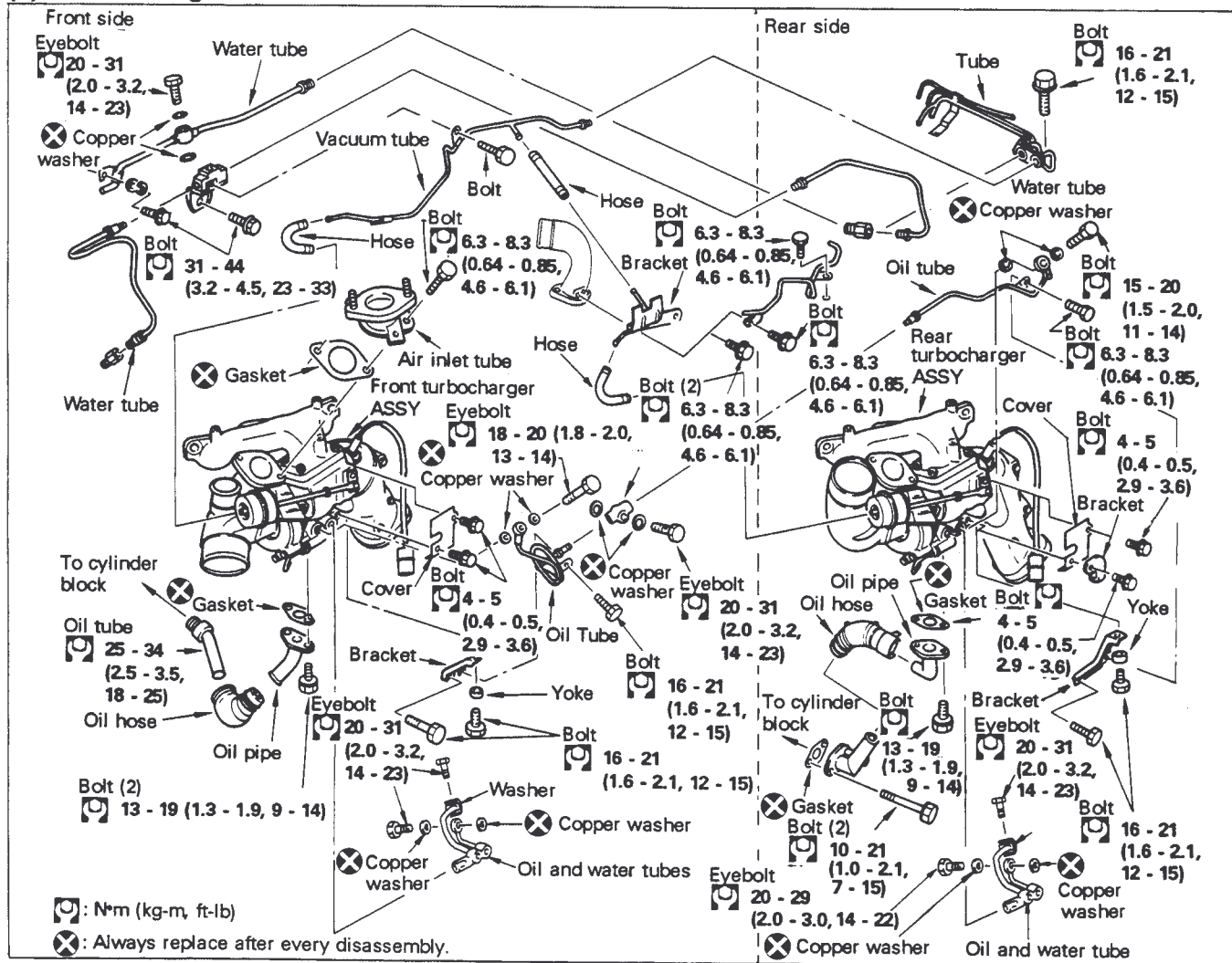

Addition work required:

- Drain and refill cooling water
- Separate exhaust front tube
- Remove and install:
 - Undercover
 - Exhaust gas sensor connector
 - Intercooler air inlet tube, hose
 - Air inlet hose

Note: Also remove cooling water from engine drain plug.

(If water is only drained from radiator drain cock, the water inside cylinder block is not drained completely.)

B2 RB26 DOHC EGI (ECCS) TWIN-TURBOCHARGER ENGINE

10. Removal and Installation of On-vehicle Parts (Cont'd)

(2) Front turbocharger ASSY installation

Removal sequence

- ① Loosen the flare nuts of tubes **A** and **B**.
- ② Remove bolts, and detach tube **A**.
- ③ Loosen flare nuts of tubes **C** and **D** on the turbo side.
- ④ Remove hose **B** and bolts.
- ⑤ Remove bolts and detach tube **E**.
- ⑥ Remove eyebolts **F** and **G**.
- ⑦ Remove the two bolts and detach tube **H**. Make sure that bolt mounted on upper side is shorter than lower side.
- ⑧ Remove the three bolts, cover and ground cable.
- ⑨ Remove oil return hose.
- ⑩ Remove the three bolts and detach bracket.
- ⑪ Remove the four turbocharger bolts.
- ⑫ Lower turbocharger carefully.
- ⑬ Remove the six exhaust manifold nuts.
- ⑭ Pull the exhaust manifold in direction ① and then raise it in direction ② to avoid turbocharger stud.
- ⑮ Remove exhaust manifold.
- ⑯ Pull out turbocharger.

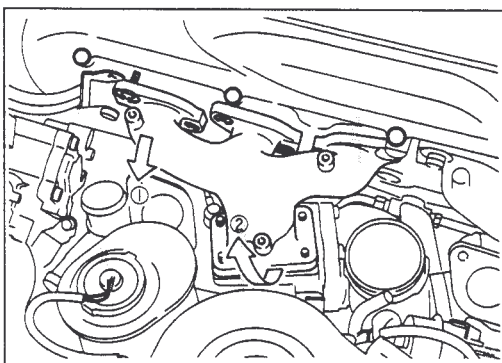
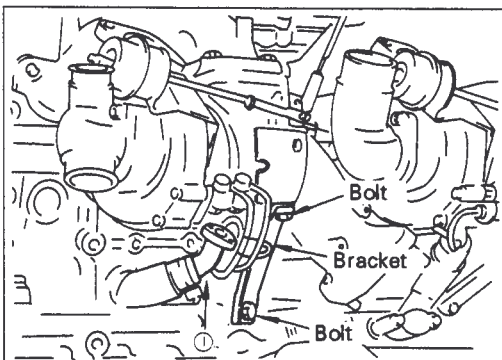
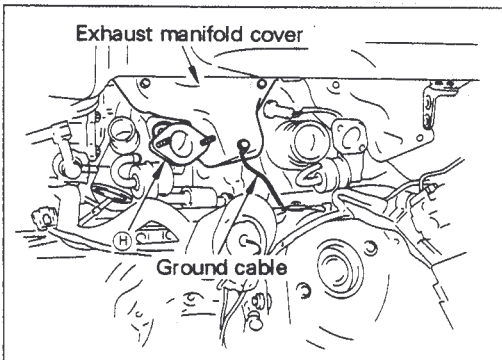
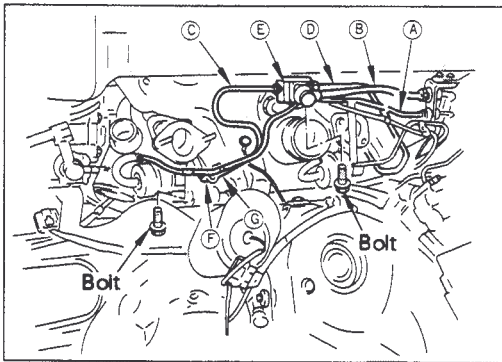

Installation sequence

- Installation is the reverse of the removal sequence.
- Place turbocharger in bottom of engine compartment before installing exhaust manifold.

B2 RB26 DOHC EGI (ECCS) TWIN-TURBOCHARGER ENGINE

10. Removal and Installation of On-vehicle Parts (Cont'd)

(3) Rear turbocharger ASSY removal and installation

Additional work required: remove and install front turbocharger ASSY

Removal sequence

- ① Remove front turbocharger and exhaust manifold ASSY.
- ② Remove the two nuts and clip securing bolt, and separate tube **A**.
- ③ Remove the three bolts and detach exhaust manifold cover.
- ④ Remove eyebolts **B** and **C** and detach bolt **E**.
- ⑤ Remove the two bolts and separate tube **D** from cylinder block side.
- ⑥ Remove the three bolts and detach bracket.

The sequence after this step is the same as numbers ⑪ to ⑯ of front turbocharger removal and installation.

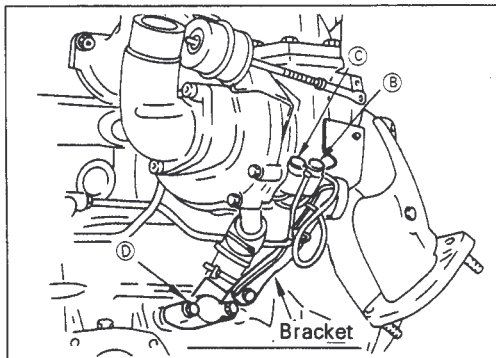
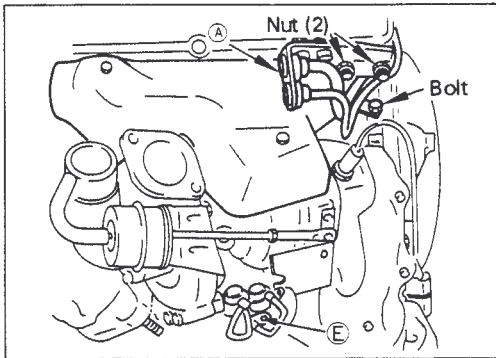

Installation sequence

- Installation is the reverse of the removal sequence.
- Before installing eyebolt **B**, loosen water tube flare nut as shown in figure on the left.

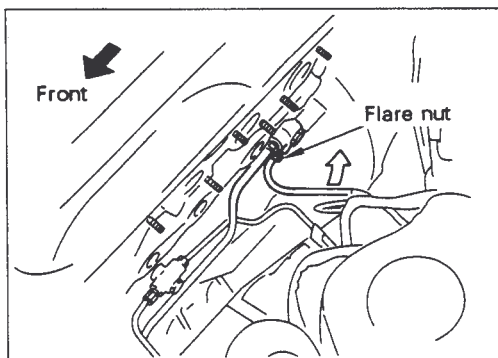

B2 RB26 DOHC EGI (ECCS) TWIN-TURBOCHARGER ENGINE

10. Removal and Installation of On-vehicle Parts (Cont'd)

(4) Turbocharger ASSY — Assembly and disassembly

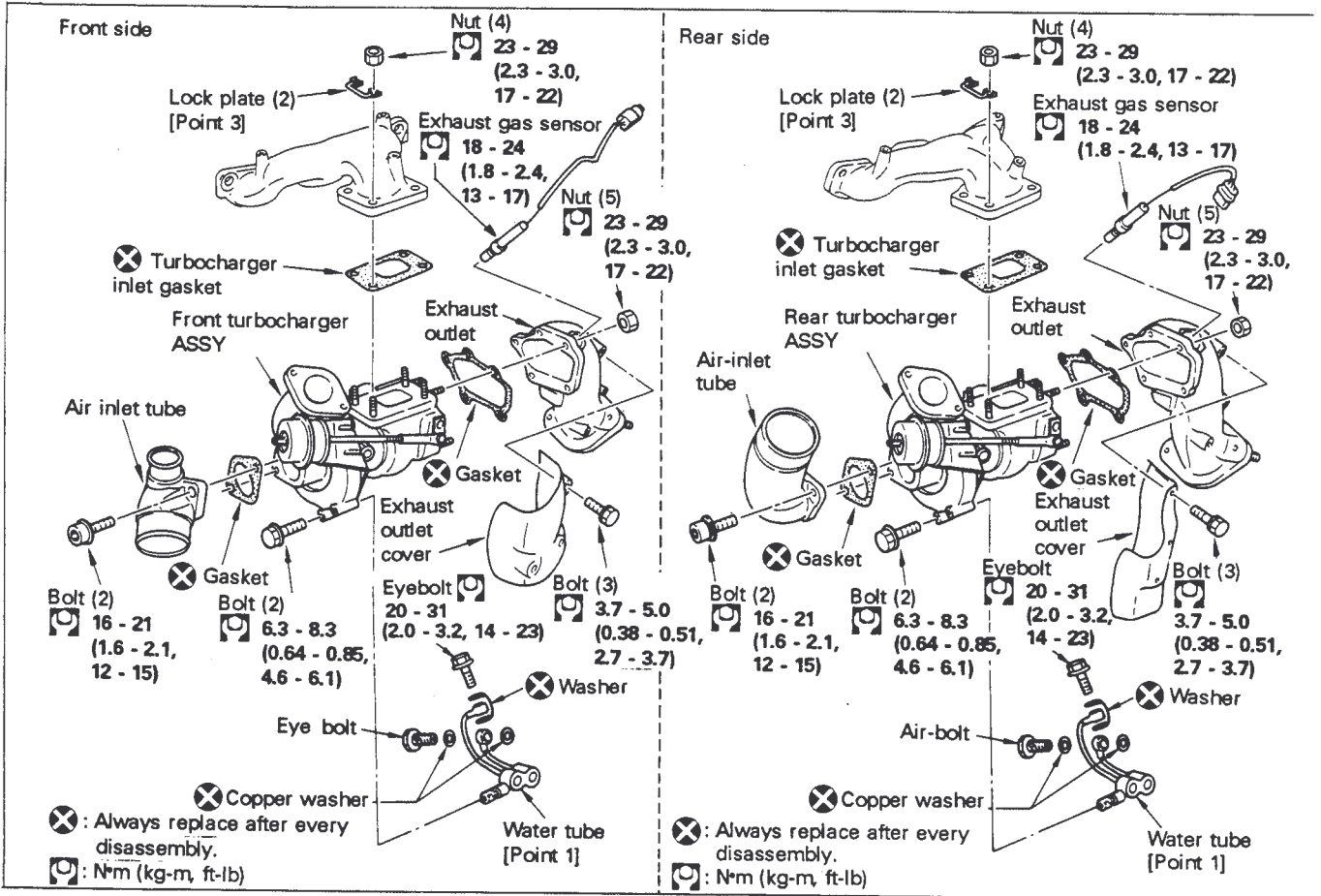

Additional work required:
 Turbocharger ASSY removal and installation

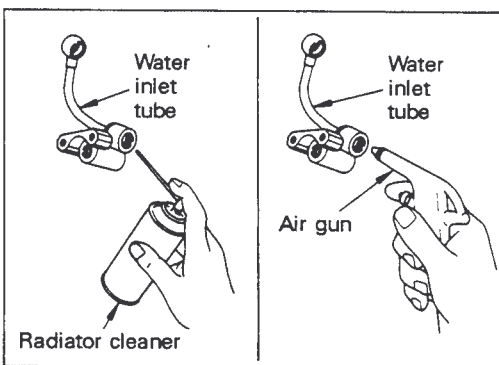

[Point 1] Water tube inspection

- After cleaning water inlet and outlet tubes with radiator cleaner, blow with compressed air and check for rust or clogging.

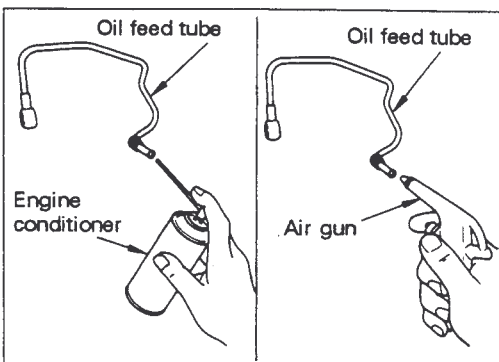

[Point 2] Oil feed tube inspection

- After cleaning oil feed tube with engine conditioner, blow with compressed air and check for clogging.

B2 RB26 DOHC EGI (ECCS) TWIN-TURBOCHARGER ENGINE

10. Removal and Installation of On-vehicle Parts (Cont'd)

[Point 3] Lock plate removal and installation

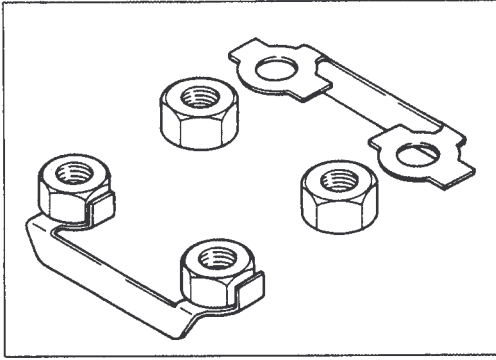

Removal

- Spread the lock plate pawls with a screwdriver and loosen the nuts.

Installation

- Position lock plates and turbocharger mounting nuts. After tightening the nuts, bend lock plate pawls onto the nuts.

[Point 4] Eye-bolt determination

- Oil feed (turbocharger side) eye bolts are stamped "J".

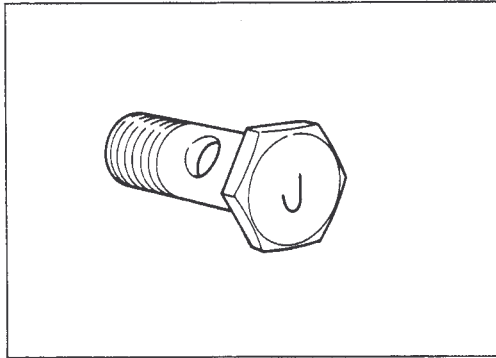

(5) Turbocharger unit inspection

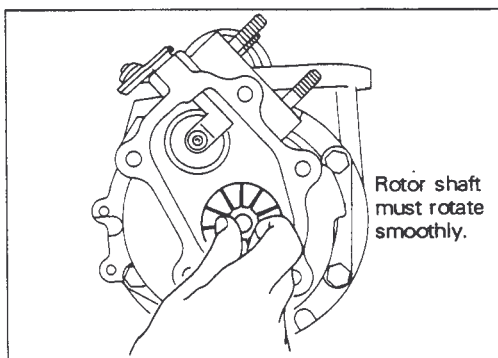
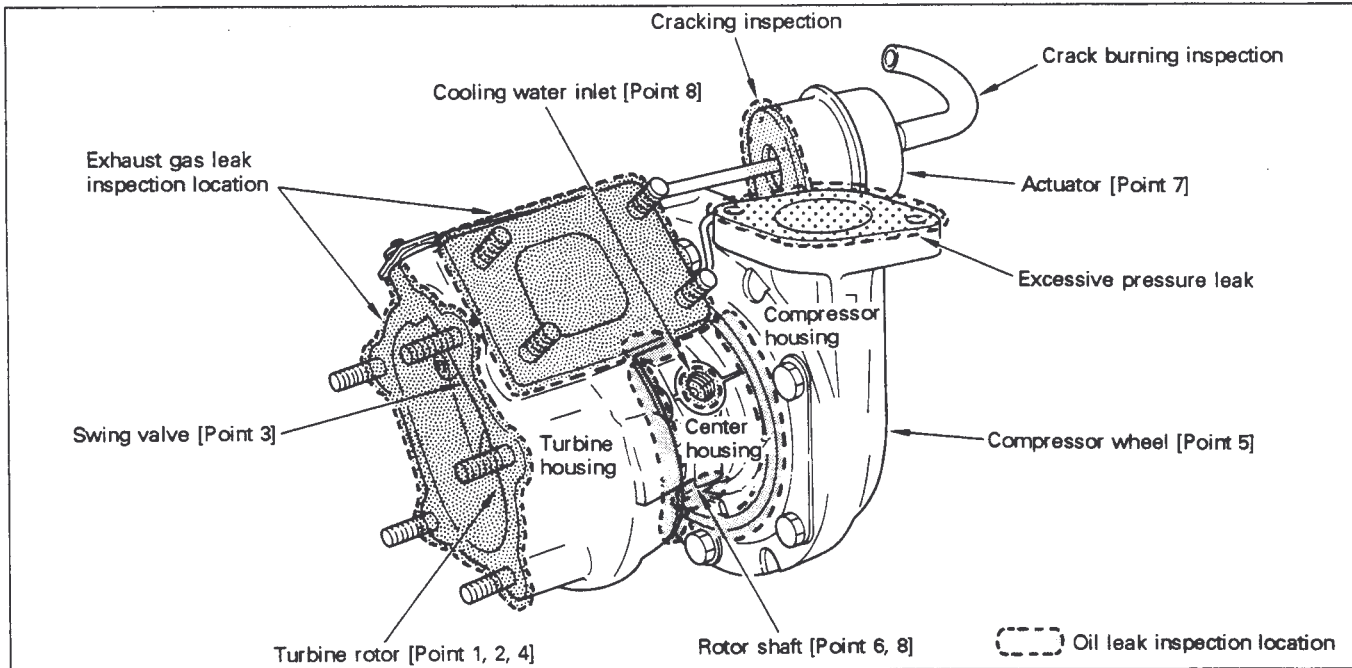

[Point 1] Rotor shaft inspection

- When rotor shaft is turned by finger, there must be no heaviness or dragging and shaft must turn smoothly.

B2 RB26 DOHC EGI (ECCS) TWIN-TURBOCHARGER ENGINE

10. Removal and Installation of On-vehicle Parts (Cont'd)

[Point 2] Turbine rotor inspection

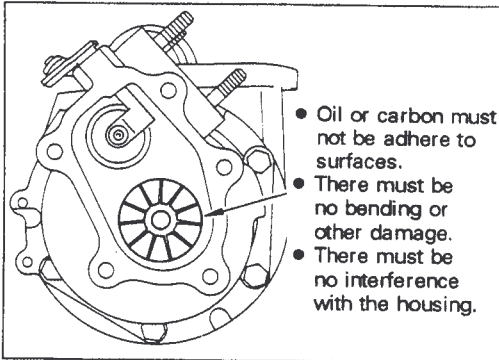

- Oil must not adhere to surfaces.
- There must be no carbon accumulation.
- The vanes of the turbine rotor must not be bent.
- There must be no interference with turbine housing.

[Point 3] Swing valve inspection

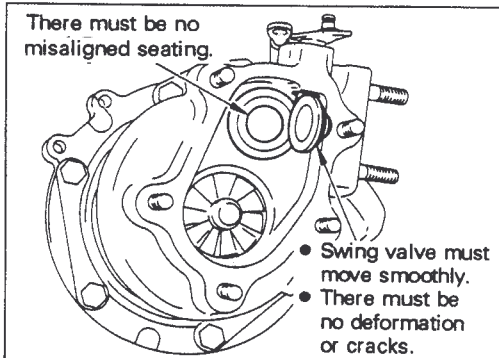

- Remove actuator rod pin and make sure switch valve moves smoothly, without deformation or cracks.
- Make sure there are no misaligned seating surfaces in turbine housing.

[Point 4] Rotor shaft play inspection

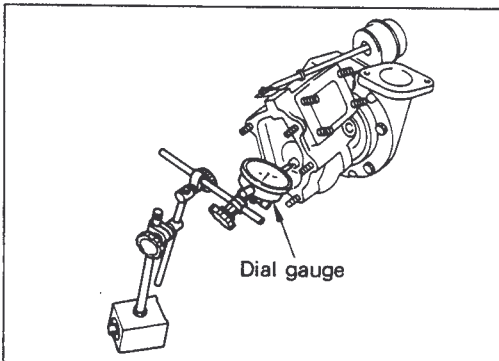

- Position a dial gauge and measure play and thrust clearance.
- Insert dial gauge in oil return hole and measure rotor shaft play.

Rotor shaft play	0.056 - 0.127 mm (0.0022 - 0.0050 in)
Thrust clearance	0.013 - 0.096 mm (0.0005 - 0.0038 in)

[Point 5] Compressor wheel inspection

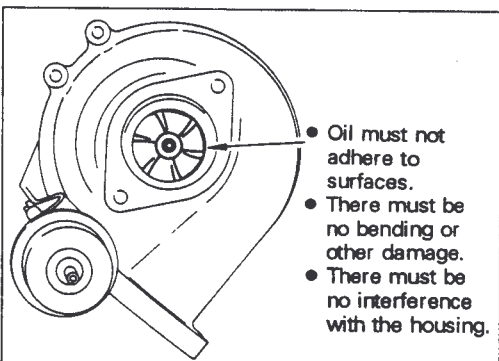

- Oil must not adhere to suction inlet.
- There must be no interference with compressor housing.
- Wheel must not be bent, folded or otherwise damaged.

[Point 6] Rotor shaft damage

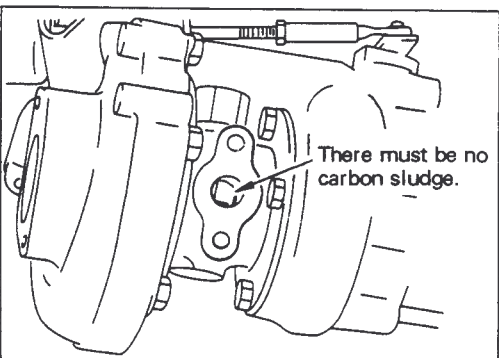

- There must be no carbon sludge accumulation.

B2 RB26 DOHC EGI (ECCS) TWIN-TURBOCHARGER ENGINE

10. Removal and Installation of On-vehicle Parts (Cont'd)

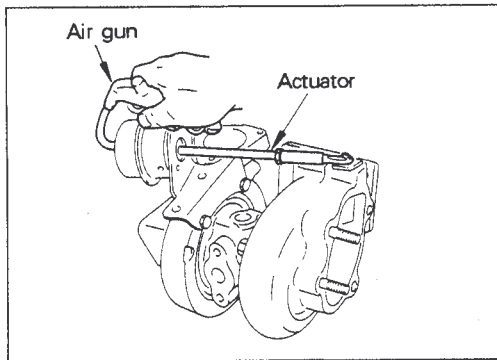

[Point 7] Swing valve controller inspection

- Connect the swing valve controller rubber hose to actuator side.
- Check swing valve controller whenever actuator rod is installed or removed.
- Use air gun to blow compressed air [approx. 69 to 78 kPa (0.7 to 0.8 kg/cm², 10 to 11 psi)] into hose and make sure swing valve controller rod operates. Stop blowing air as soon as rod operates.

CAUTION:

If air pressure is applied excessively the diaphragm may be damaged. Use the LPG pressure gauge [special tool for approx. 98 kPa (1 kg/cm², 14 psi)] to verify that the air gun pressure is approx. 78 to 88 kPa (0.8 to 0.9 kg/cm², 11 to 13 psi) before testing the air hose.

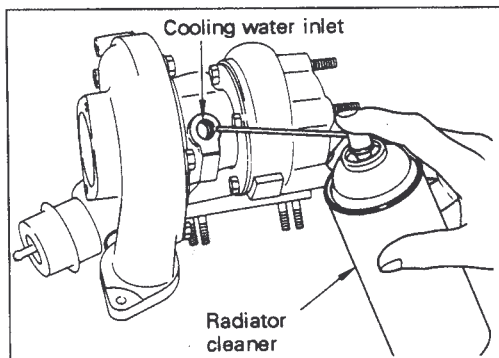

[Point 8] Oil and cooling water inlet and outlet cleaning

- Use engine conditioner to clean oil feed and return passages.
- Use radiator cleaner to clean cooling water feed and return passages.

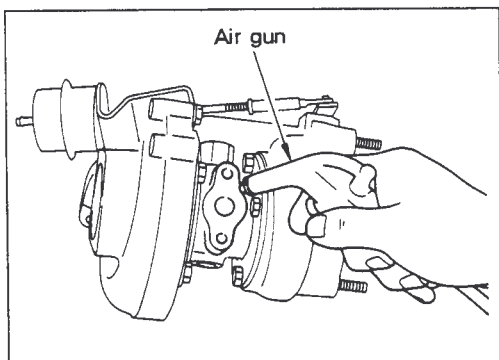

- Clean with air gun

Clean compressor wheel, turbine wheel, compressor housing and turbine housing with same methods.

B2 RB26 DOHC EGI (ECCS) TWIN-TURBOCHARGER ENGINE

(6) Turbocharger trouble diagnosis (oil leaks, smoke (white or blue smoke), lack of power, poor acceleration, abnormal noise)

Items to be verified before diagnosis

- ① The engine oil level must be between the MIN and MAX marks on the oil level gauge.
(When higher than MAX, engine oil flows into the intake duct through the blowby gas recirculation pass and turbocharger may be determined to be malfunctioning.)
- ② Check with customer to determine if oil is cooled when idling after driving.
If even one malfunction in the following chart is detected in a unit inspection, replace the turbocharger ASSY.

If none of these conditions are found during inspection, assume there are no turbocharger problems and search for a malfunction in another location.

Item *Reference	Inspection location	Symptom	Possible associated phenomenon			
			Oil leak	Smoke	Abnormal noise	Lack of power or poor acceleration
2.8	Turbine rotor	Turbine has oil on rotors.	△	●	△	△
		Carbon has accumulated.	△	●	○	○
		Rotor scrapes against the housing.	△	○	●	○
		The turbine vanes are bent or folded.			●	●
5.8	Compressor wheel	Suction inlet is dirty with oil.	○	○		
		Rotor scrapes against the housing.	△	○	●	○
		The turbine vanes are bent or folded.			●	●
1.4.8	<ul style="list-style-type: none"> ● Both turbine and compressor ● Rotor shaft play inspection 	There is strong resistance or scraping when rotated by finger.		△	△	○
		Rotation by finger is not possible.				●
		There is considerable shaking between rotor shaft and turbo ASSY.	△	△	○	△
6.8	Look through oil hole. (Inspect interior with penlight.)	Carbon sludge has accumulated in waste oil hole.	△	●	△	△
3.7	Swing valve motion. (Use air gun or air pump.)	The valve does not move smoothly when pressure is applied gradually. (The valve normally opens at pressure greater than [59 to 69 kPa (0.6 to 0.7 kg/cm ² , 9 to 10 psi)].				●

*: Refer to previous section (5).

[●: Highly possible ○: Possible △: Slightly possible]

B2 RB26 DOHC EGI (ECCS) TWIN-TURBOCHARGER ENGINE

10-8 EXHAUST MANIFOLD ASSY REMOVAL AND INSTALLATION

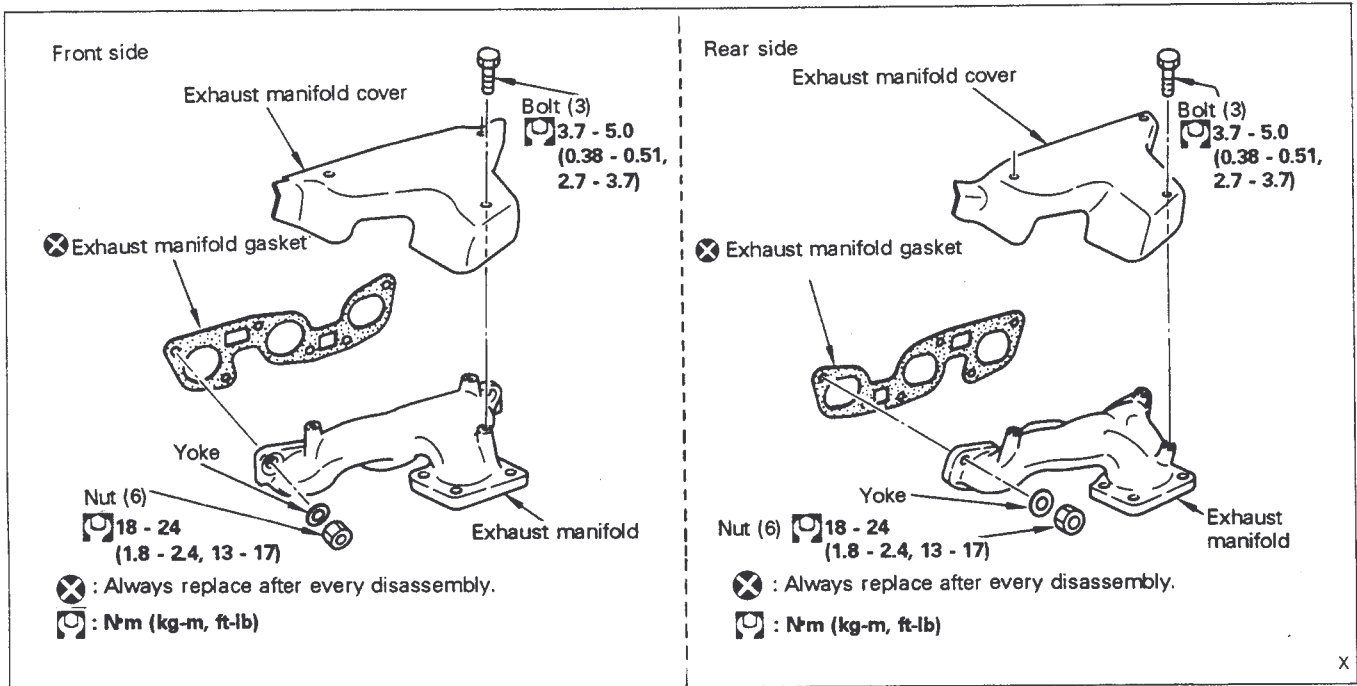

Additional work required:

- Turbocharger removal and installation (Refer to section 10-7)
- Gas leak inspection [Point 1]

[Point 1] Gas leak inspection

- After removing exhaust manifold, make sure there are no traces of gas leaks from any part of installation.
- After installation, crank engine and check for gas leaks.

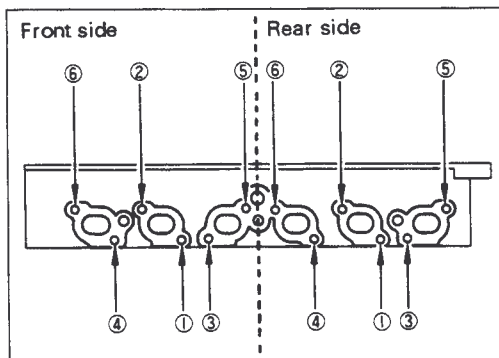

[Point 2] EXHAUST MANIFOLD NUTS REMOVAL AND INSTALLATION

Removal

- Removal is the reverse of installation sequence shown in figure.

Installation

- The installation sequence is shown in the figure.

Tightening torque	18 - 24 N·m (1.8 - 2.4 kg-m, 13 - 17 ft-lb)
-------------------	---

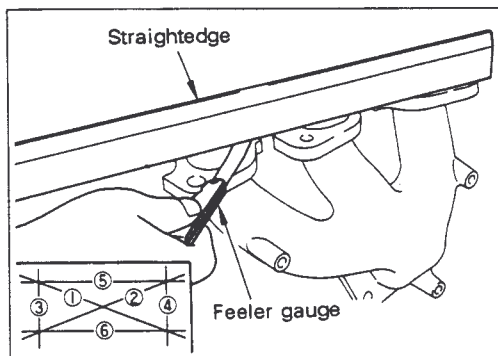

[Point 3] Exhaust manifold inspection

- Measure the intake manifold surface for distortions in six separate directions (opposite directions; up, down, right, left, horizontally and vertically) in a number of locations.

Limit	0.3 mm (0.012 in)
-------	-------------------

- Check that no oil, dirt or foreign matter adheres to cylinder head, exhaust manifold installation surface and gasket.

B2 RB26 DOHC EGI (ECCS) TWIN-TURBOCHARGER ENGINE

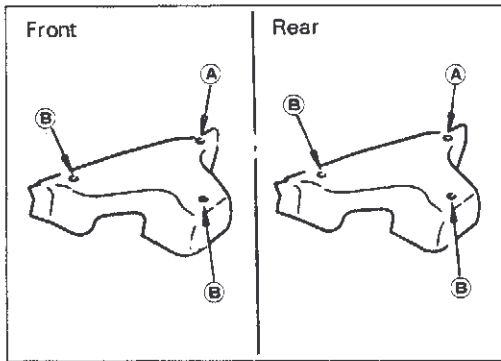

[Point 4] Exhaust manifold cover installation

- Attach the exhaust manifold cover bolts in the following sequence (in both front and rear).
 - ① Temporarily tighten bolts for positioning hole indicated by **(A)**.
 - ② Tighten bolts in the other two locations **(B)**.
 - ③ Tighten bolts in holes **(A)** to specified tightening torque.

Tightening torque	3.7 - 5.0 N·m (0.38 - 0.51 kg·m, 2.7 - 3.7 ft·lb)
-------------------	---

10-9 SPARK PLUGS

Tools required

	Name	Application
Special tool	Spark plug wrench EG1740 1600	Small hexagonal spark plug removal and installation

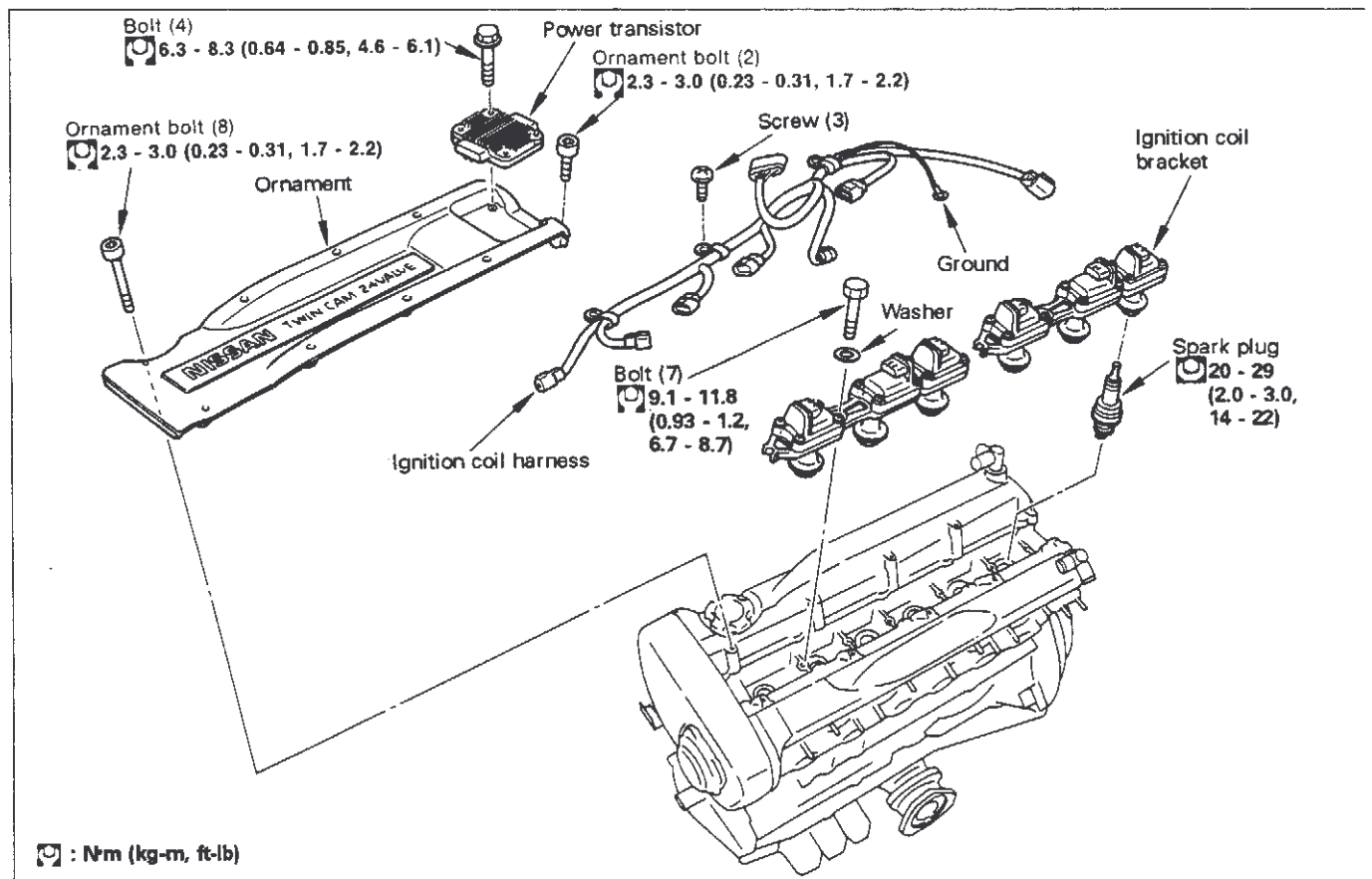

Additional work required:

Remove and install:

- Air inlet pipe
- Blowby hose

B2 RB26 DOHC EGI (ECCS) TWIN-TURBOCHARGER ENGINE

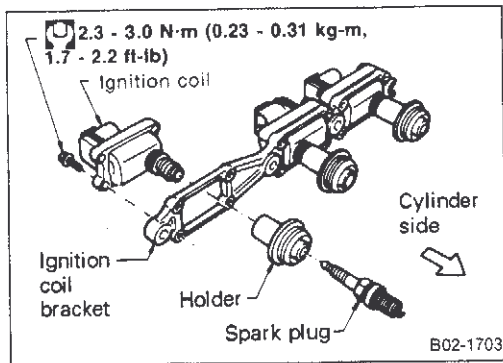

[Point 1] Ignition coil bracket removal and installation

Removal

- When removing ignition coil bracket, hold coil to provide additional support while detaching it.

CAUTION:

Do not hold the coil by the connector when removing it.

Installation

- When installing ignition coil bracket to cylinder head, check that ground line is connected securely.

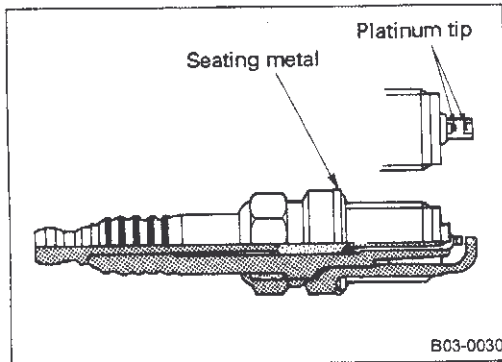

[Point 2] Spark plug maintenance

- Gap inspection and adjustment is not necessary because a platinum tip is used.
- Change spark plugs every 100,000 km (60,000 miles).
- When using a compressed air spark plug cleaner, clean the plugs at maximum pressure of 588 kPa (6 kg/cm², 85 psi) for no more than 20 seconds.
- Do not use a wire brush to clean plugs.

10-10 ROCKER COVER REMOVAL AND INSTALLATION

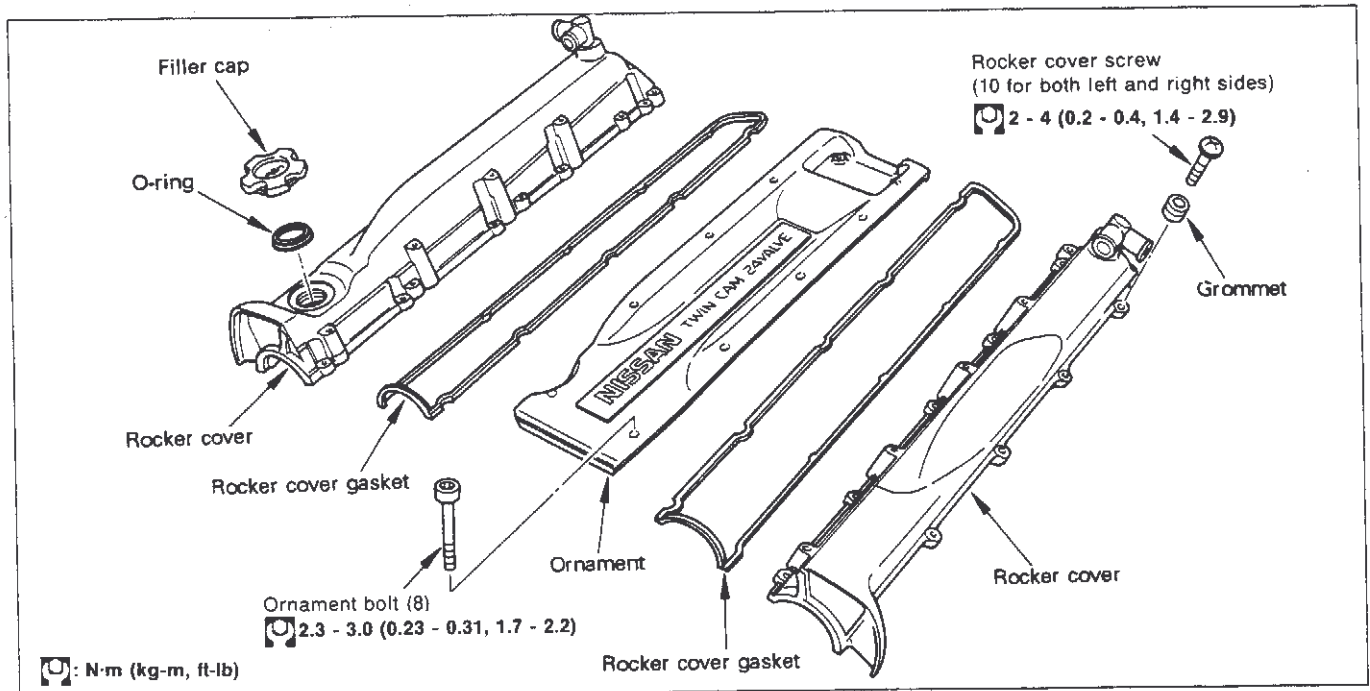

Additional work required:

Remove and install:

- Air inlet pipe
- Blowby hose

B2 RB26 DOHC EGI (ECCS) TWIN-TURBOCHARGER ENGINE

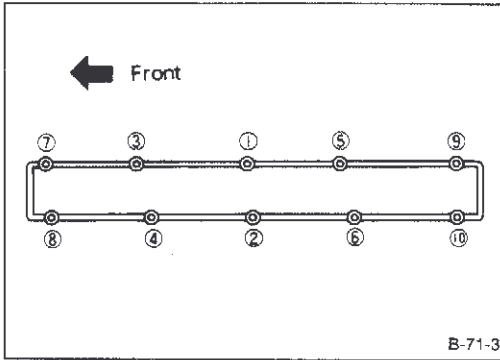

[Point 1] Rocker cover screw removal and installation

Removal

- Perform removal in reverse of sequence shown in the figure on the left.

Installation

- Perform installation in sequence shown in the figure on the left.

CAUTION:

Perform removal and installation for intake and exhaust sides by same method.

Tightening torque

2 - 4 N·m (0.2 - 0.4 kg-m, 1.4 - 2.9 ft-lb)

[Point 2] Rocker cover installation surface inspection

- Check that no oil, dirt or foreign matter adheres to the cylinder head installation surface.

[Point 3] Rocker cover gasket installation

- Make sure the rocker cover gasket is positioned securely in groove without twisting, pinching or protrusion.

B2 RB26 DOHC EGI (ECCS) TWIN-TURBOCHARGER ENGINE

10-11 TIMING BELT REMOVAL AND INSTALLATION

Tools required

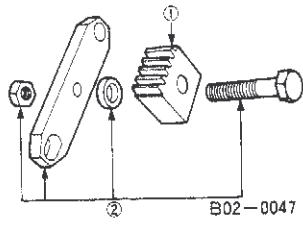
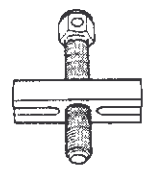
	Name	Application
Special tool	Ring gear stopper KV101 104S0 ① Adapter KV101 10410 ② Stopper plate KV101 05610	 Crank pulley bolt removal and installation
	Pulley puller ST2718 0001	 Crank pulley removal and installation

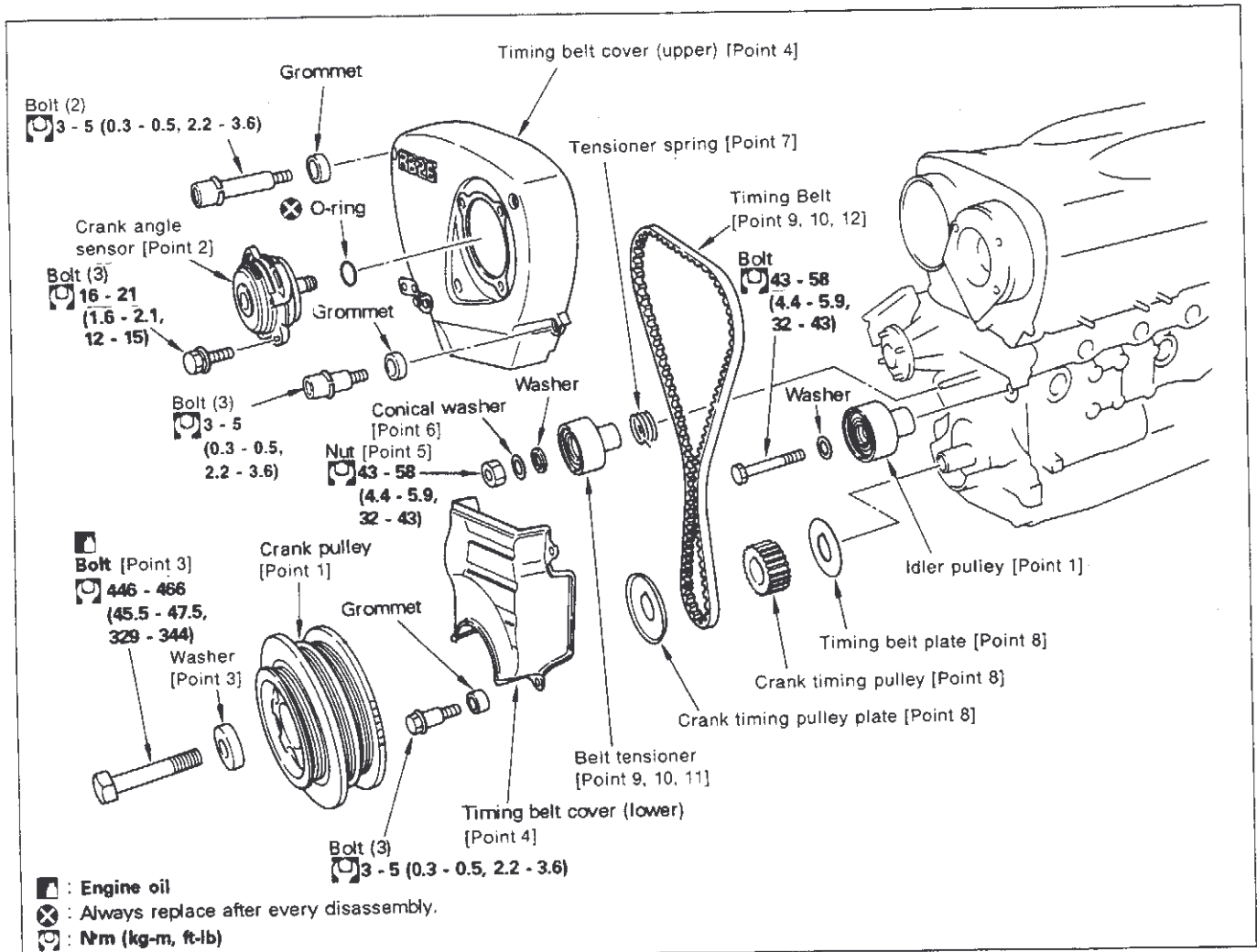

Additional work required:

- Drain and refill: Cooling water
- Remove and install:
 - Under cover
 - Radiator, fan shroud
 - Cooling fan

Supplemental belts

- Water pump pulley
- Spark plugs

- Check No. 1 cylinder compression T.D.C. position [Point 1]
- Install ring gear stopper [Point 3]

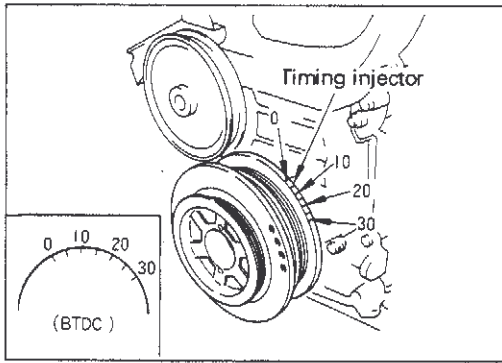

[Point 1] No. 1 cylinder pressure T.D.C. (top dead center) inspection

- Align the crank pulley timing mark and belt cover timing indicator (0° position).
At this time, the No. 1 cylinder is in the compression T.D.C. position when the camshaft is located as described below.

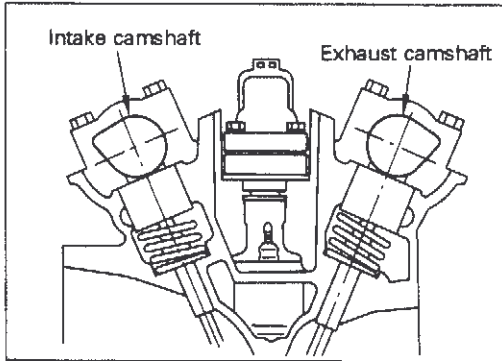

- No. 1 cylinder is at the compression stroke top dead center when both the intake and exhaust side cams do not move the valve lifters.

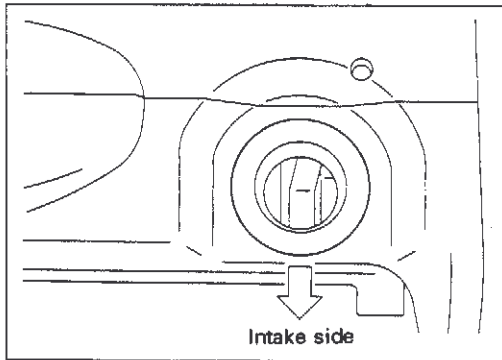

- Remove oil filler cap from intake side rocker cover and check that the front end of camshaft faces the intake side.

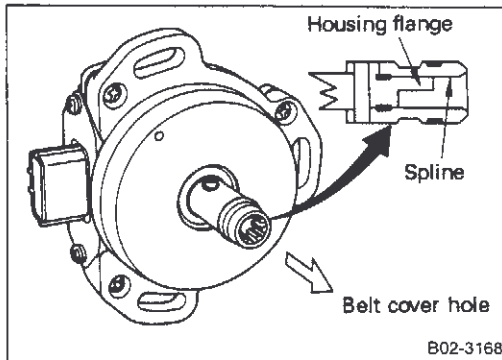

[Point 2] Crank angle sensor installation

- Apply chassis grease to drive unit spline during installation.
- There is a flange inside drive unit spline so spline only has one insertion position. Check the alignment visually before assembly.
- Check that crank angle sensor can be easily inserted in belt cover holes and sensor moves lightly to right and left, then tighten bolts.
- When sensor does not move lightly, loosen belt cover bolts to position when crank angle sensor was inserted. Move belt cover lightly horizontally and vertically to align it so belt cover holes and camshaft center are aligned and then tighten bolts so crank angle sensor moves lightly.

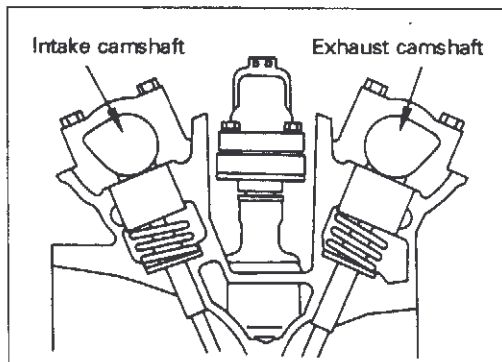

B2 RB26 DOHC EGI (ECCS) TWIN-TURBOCHARGER ENGINE

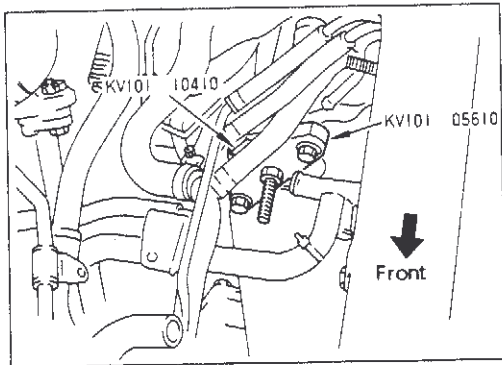

[Point 3] Removal and installation of crank pulley and bolt

Removal

- Remove starter motor, and attach ring gear stopper. (Refer to B5 starter motor removal and installation.)
- Use a pulley puller (steering wheel puller) to remove crank pulley. [Bolt size: M6 x 1.0, length below head approx. 50 mm (1.97 in).]

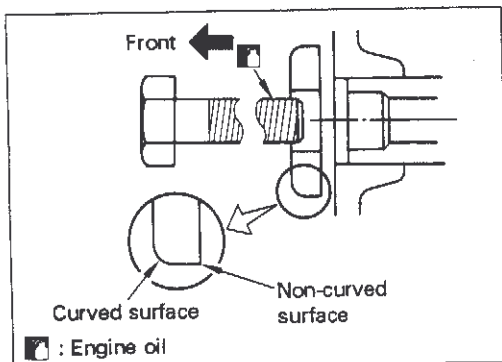
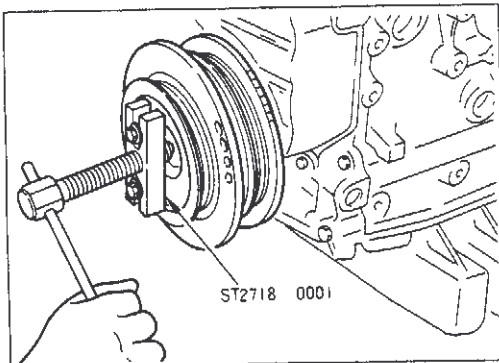

Installation

- Position the washers for the crank pulley bolts so the flat surface contacts the crank pulley side and then assemble.
- Apply a coat of engine oil to the threads of crank pulley bolts.

Tightening torque	446 - 466 N·m (45.5 - 47.5 kg·m, 329 - 344 ft·lb)
-------------------	---

[Point 4] Timing belt cover removal and installation

Removal

- Timing belt cover is separated into upper and lower sections. After crank angle sensor is removed, first remove the upper section and then remove lower section in this sequence.

Installation

- Installation is performed in reverse sequence of removal.

CAUTION:
Do not scratch dried liquid packing when removing and installing timing belt cover.

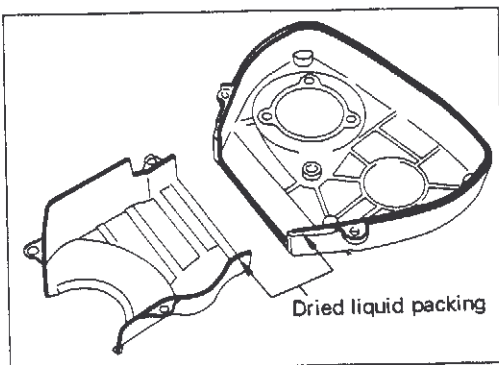

Tightening torque	3 - 5 N·m (0.3 - 0.5 kg·m, 2.2 - 3.6 ft·lb)
-------------------	---

B2 RB26 DOHC EGI (ECCS) TWIN-TURBOCHARGER ENGINE

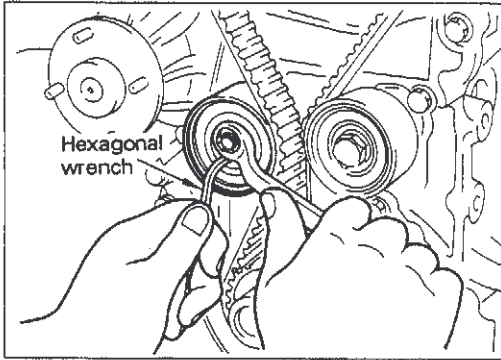

[Point 5] Belt tensioner nut removal and installation

- When removing and installing belt tensioner nuts, secure the tensioner firmly with a hexagonal wrench.

CAUTION:

Do not loosen inserted stud at disassembly.

Tightening torque	43 - 58 N·m (4.4 - 5.9 kg-m, 32 - 43 ft-lb)
-------------------	---

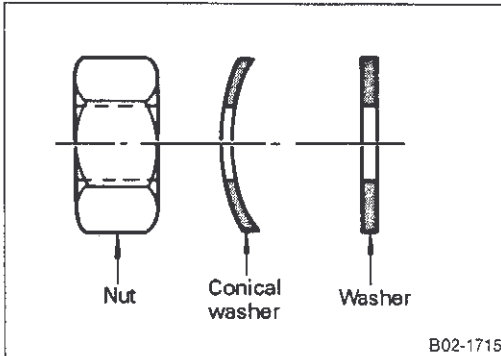

[Point 6] Conical washer installation

- Pay close attention to the installation direction of conical washers. The washer should be set with face the chamfered side facing the tensioner pulley side.

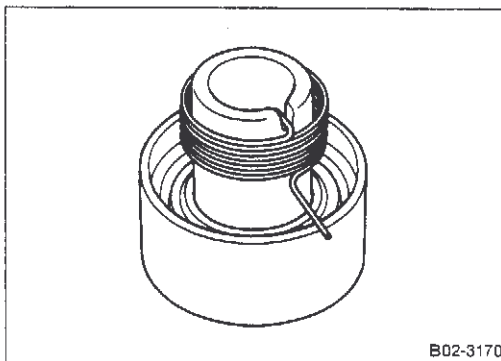

[Point 7] Tensioner spring installation

- Assemble the tensioner spring so it engages the belt tensioner pulley as shown in the figure.
- The tensioner spring must be assembled together with the belt tensioner pulley in the cylinder block.

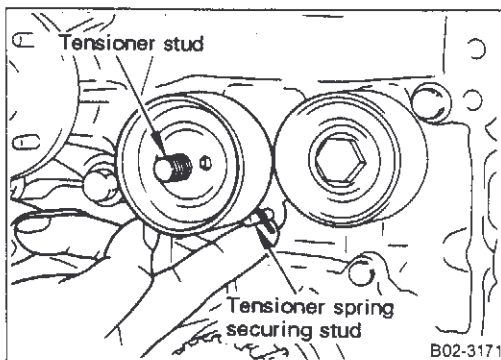

- When tensioner pulley is free, hook the tensioner spring on the upper side of tensioner spring stud.

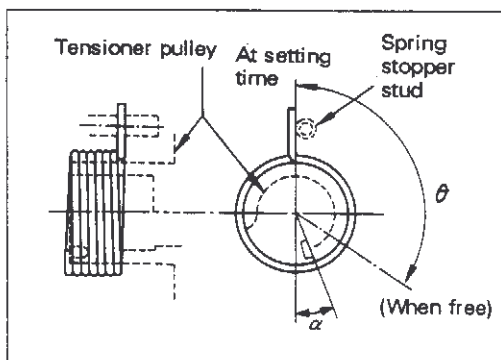

Tensioner spring specifications

Spring wire diameter	Set angle: α	Free angle: θ	Classification paint
1.8 mm (0.071 in)	Approx. 20°	Approx. 163°	Yellow-green

B2 RB26 DOHC EGI (ECCS) TWIN-TURBOCHARGER ENGINE

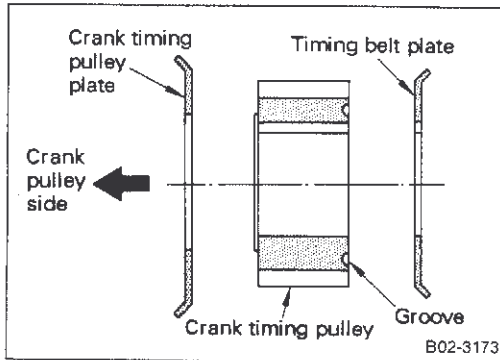

[Point 8] Crank timing pulley and plate installation

- Be careful to observe front and rear positioning of timing belt plate, crank timing pulley and crank timing pulley plate when installation is performed.

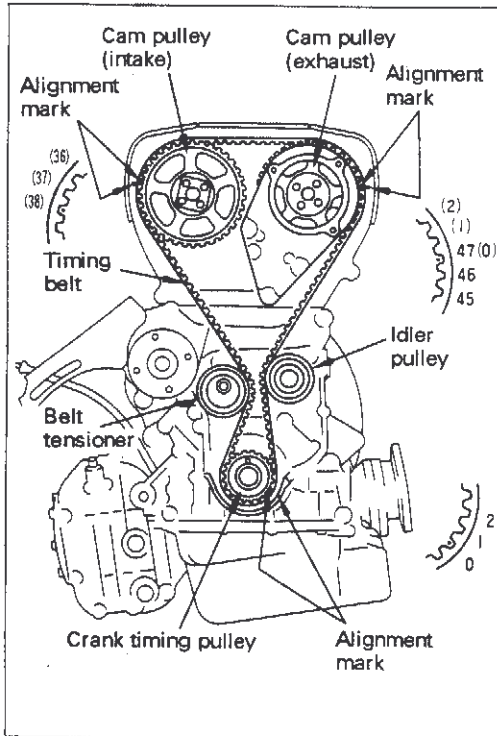

[Point 9] Timing belt alignment mark verification and installation

If paint on upper belt is unclear when disassembly is performed, paint a mark on belt that indicates rotation direction.

- Position the alignment marks of the intake and exhaust cam pulleys with the respective belt cover alignment marks. (No. 1 cylinder is at T.D.C.)
- Align the crank timing pulley alignment mark with the mark on oil pump housing. The groove must be straight up at this time. (No.1 cylinder compression T.D.C.)
- Move the belt tensioner clockwise at a 70 - 80° angle, and secure it temporarily with belt tensioner nut. (This will minimize the offset between the tensioner shaft and timing belt.)
- Align timing belt pulley marks and install belt. Align the number of ridges of exhaust cam pulley alignment mark and crank pulley (inner) alignment mark as shown in the figure on left.
- After loosening nuts and adjusting belt tension, secure tensioner with hexagonal wrench so it does not rotate together and tighten nut.

CAUTION:

- (1) At timing belt assembly, check that it engages correctly with pulley and does not float.
- (2) When disassembly is performed, replace belts whenever possible.

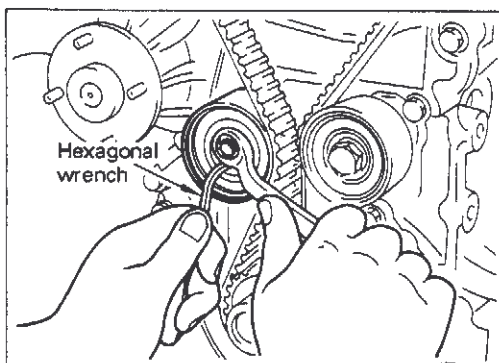

[Point 10] Timing belt tension adjustment

- Remove spark plugs, and align timing belt alignment marks with pulley marks and install timing belt onto each pulley.
- Loosen tensioner securing nut so belt tension is applied by tensioner spring.
- In this condition, turn crank pulley more than two turns clockwise to check belt movement and stop slowly at No. 1 cylinder compression T.D.C. point.
- Insert the hexagonal wrench in hexagonal hole. While holding it by hand so the tensioner does not move, tighten the tensioner securing nut to specified tightening torque.

Tightening torque	43 - 58 N·m (4.4 - 5.9 kg-m, 32 - 43 ft-lb)
-------------------	---

- The initial tension on the belt should be approximately 196 N (20 kg, 44 lb) in this condition.



B2 RB26 DOHC EGI (ECCS) TWIN-TURBOCHARGER ENGINE

[Point 11] Idler and tensioner pulley installation

- Do not loosen inserted studs at disassembly. If studs are loosened, coat inserted stud with Loctite solution (Japan Loctite KK) or equivalent.

[Point 12] Timing belt inspection

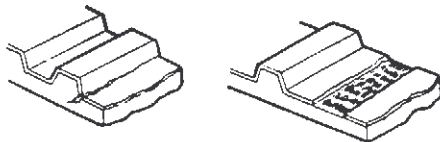
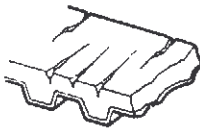
- Replace timing belt if inspection indicates any problem.

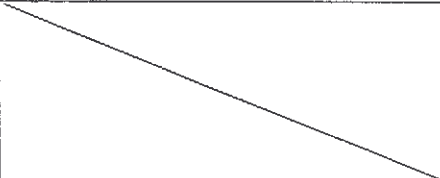
Item	Condition	Cause
Missing tooth Cracked tooth		Camshaft lock Crank angle sensor lock
Cracks in rear side		Tensioner lock Engine overheating Interference with belt cover, etc.
Wear and cracks on side surface		Belt misalignment Belt plate malfunction
Worn teeth		Large sliding motion resistance in crank angle sensor and crankshaft
Oil or water adhesion		Oil seal malfunction Water leaks in water pump

CAUTION:





Make sure timing belt is not twisted or bent sharply. Also make sure there is no oil film or water on belt.

B2 RB26 DOHC EGI (ECCS) TWIN-TURBOCHARGER ENGINE

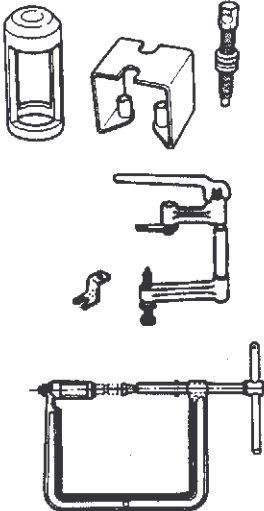

10-12 CYLINDER HEAD ASSY

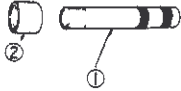
Be careful when handling exhaust valves because metallic sodium is sealed inside. Refer to Page EN-67.

Tools required

	Name		Application
Special tool	Pulley holder KV101 09900 or KV101 09300, ST3152 0000, ST3153 0000		Cam pulley bolt removal and installation
	Valve spring compressor KV101 11300 ST1207 0000 KV101 089S0		Valve spring installation and removal
	Valve oil seal puller KV101 07900		Valve oil seal removal
	Valve oil seal drift and drift attachment ① KV101 07501 ② KV101 14800		Valve oil seal insertion
	Valve guide drift		Valve guide installation and removal
	Valve guide reamer for guide insertion hole correction Exhaust side Guide inner diameter correction Intake side KV101 11600 6.0 mm (0.236 in) dia. Exhaust side KV101 07700 7.0 mm (0.276 in) dia.		Valve guide insertion hole and guide internal diameter correction

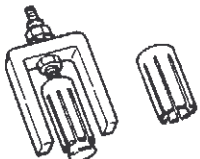
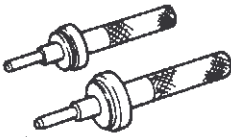
B2 RB26 DOHC EGI (ECCS) TWIN-TURBOCHARGER ENGINE

	Name	Application	
Special tool	Valve seat remover, intake side, exhaust side		Valve seat removal
	Valve seat drift intake side, exhaust side		Valve seat insertion
	Valve seat cutter set		Valve seat form correction
Tool	Valve surface grinder		
Measurement tool	Inside micrometer	Lifter guide, etc., inspection	
	Micrometer	Camshaft, etc., inspection	
	Dial gauge	Camshaft, etc., inspection	
	V-block	Camshaft, etc., inspection	
	Valve spring tester	Valve spring, etc., inspection	
	Square edge	Valve spring, etc., inspection	
	Square edge	Cylinder head, etc., inspection	

B2 RB26 DOHC EGI (ECCS) TWIN-TURBOCHARGER ENGINE

SPECIAL PRECAUTIONS TO ENSURE SAFE DISPOSAL OF SODIUM-FILLED EXHAUST VALVES

The handling and disposal of sodium-filled exhaust valves requires special care and consideration. Under conditions such as breakage with subsequent exposure to water, the sodium metal which lines the inner portion of the exhaust valve will react violently, forming sodium hydroxide and releasing hydrogen gas which may result in an explosion or fire.

- **Damage to eyes may result in loss of vision**
- **Contact with skin will result in burns**
- **Fire may occur.**

① Basic precautions

- Never attempt to break valve and remove sodium metal.
- In principle, dispose of used valves by returning them to the Nissan service office.
- If valve(s) is/are damaged, remove valve(s), and perform sodium-filled valve disposal operations (neutralization and waste water disposal).

② Processing method

In principle, dispose of used valves by returning them to the Nissan service office.

If local industrial waste treatment companies do not perform the required press processing and it is clearly established that a solvent method can be used instead, this type of disposal method is also acceptable.

If valve(s) is/are damaged, remove valve(s), neutralize by water reaction and dispose of them with the same method used for ordinary scrap metal.

Processing must be performed as follows.

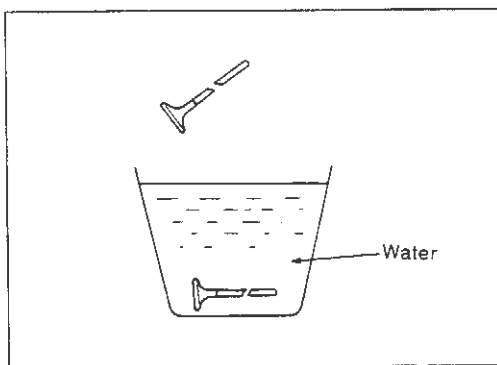

- Wear rubber gloves to remove valves from cylinder head.
- Pour more than 10 liters (2-1/4 Imp gal) of water into a bucket in a well-ventilated area.
- Submerge the damaged valves in the bucket.
- The reaction is violent so stand 2 to 3 meters (7 to 10 ft) from bucket.
- Hydrogen gas is produced so do not bring any naked flame near bucket.
- After the reaction is finished (4 - 5 hrs.), use large tweezers to pick the valves out. The valves can be disposed of by the same method used for other waste products at this time.
- Dealers should check their respective state and local regulations concerning any chemical treatment or waste water discharge permits which may be required to dispose of the resultant (high alkalinity) waste water.

CAUTION:

Make sure the resultant (high alkalinity) waste water does not contact your skin. If the waste water does contact the skin, wash the affected area immediately with large quantities of water.

B2 RB26 DOHC EGI (ECCS) TWIN-TURBOCHARGER ENGINE

(1) Cylinder head ASSY removal and installation

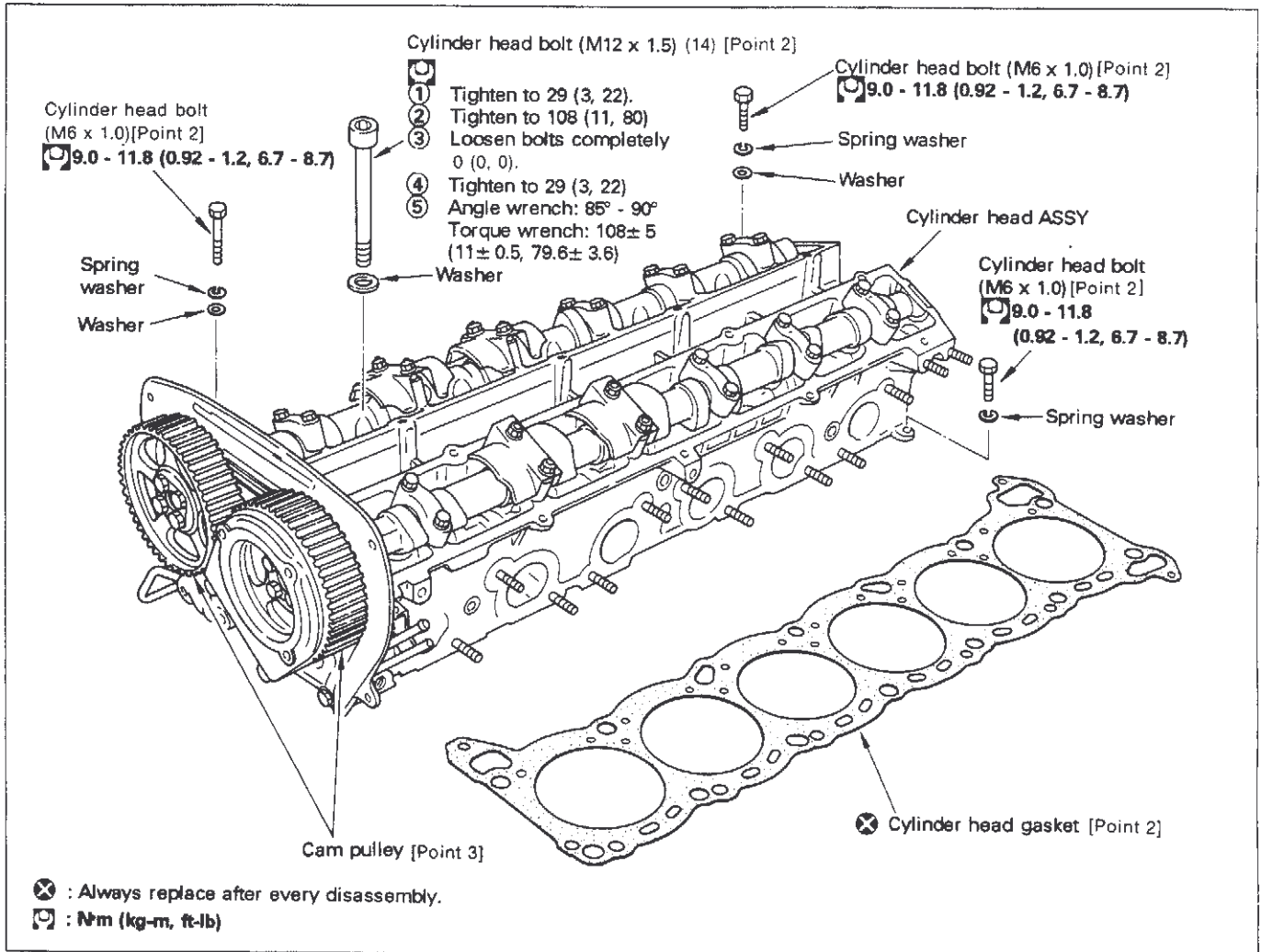

Additional work required:

- Drain and refill: Cooling water [Point 1]
- Remove and install:
 - Collector
 - Throttle chamber
 - Intake manifold

- Turbocharger, exhaust manifold
- Timing belt
- Rocker cover
- Spark plugs

- Installation: Check No. 1 cylinder compression T.D.C. position [Point 3]

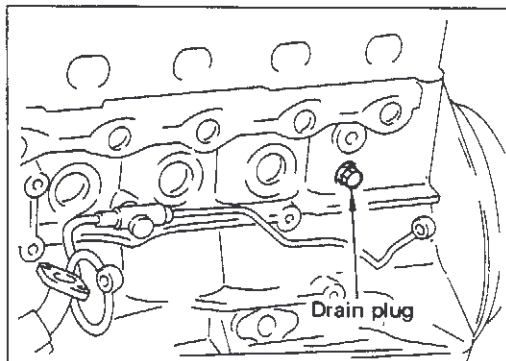

[Point 1] Cooling water drain and refill

Removal

- Remove water completely from cylinder block drain plug.

CAUTION:

Do not allow water to enter exhaust front tube.

Refilling water:

- Refer to (B6) "Cooling Water Filling Procedures" for details.

B2 RB26 DOHC EGI (ECCS) TWIN-TURBOCHARGER ENGINE

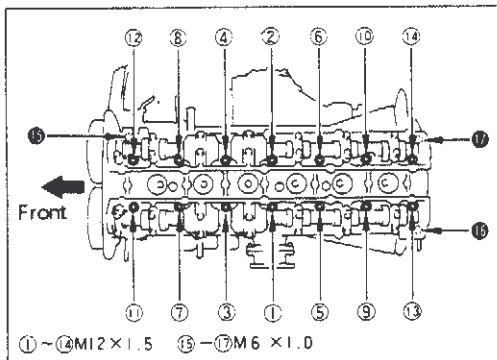

[Point 2] Cylinder head bolts removal and installation

Removal

- Remove bolts in reverse sequence of figure on left.

Installation

- Remove bolts in sequence shown in figure on left.
- The cylinder head bolts (M12 x 1.5) are torqued by a two-step method in which bolts are tightened two times.
 - ① Tighten to 29 N·m (3 kg-m, 22 ft-lb).
 - ② Tighten to 108 N·m (11 kg-m, 80 ft-lb).
 - ③ Loosen bolts completely 0 N·m (0 kg-m, 0 ft-lb).
 - ④ Tighten to 29 N·m (3 kg-m, 22 ft-lb).
 - ⑤ Turn bolts 85 to 90 degrees clockwise when angle wrench is used. Tighten bolts to 103 to 113 N·m (10.5 to 11.5 kg-m, 76 to 83 ft-lb) when torque wrench is used.

CAUTION:

When angle wrench is not used, never attempt to approximate the tightening angle visually.

- When gasket is installed, be careful not to hit or scratch gasket seat and bore grommet.
- When gasket is installed, clean cylinder head lower surface and cylinder block upper surface and remove all water, oil and foreign matter. Use compressed air to blow out the bore holes.

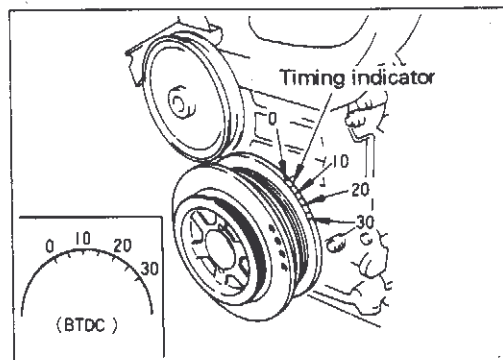
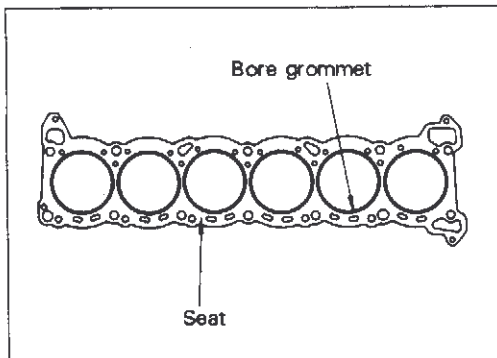
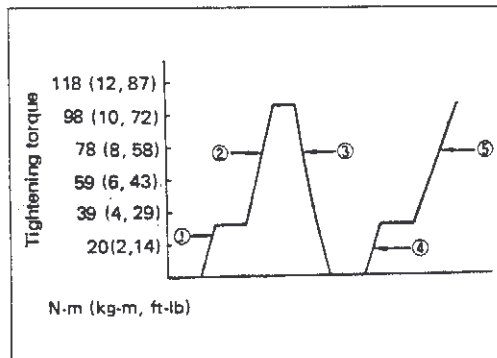

[Point 3] No. 1 cylinder compression T.D.C. verification

Before installing cylinder head ASSY on cylinder block, the crank pulley and cam pulley must be positioned at the No. 1 cylinder compression T.D.C. point.

- The crank pulley timing mark and timing belt cover timing indicator (0°) must be aligned.
- Intake and exhaust cam pulley alignment marks must be positioned with their respective belt cover alignment marks.

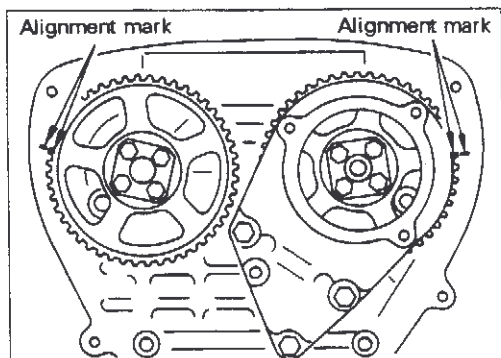

B2 RB26 DOHC EGI (ECCS) TWIN-TURBOCHARGER ENGINE

(2) Cylinder head ASSY disassembly and assembly

Special Precautions to Ensure Safe Disposal of Sodium-filled Exhaust Valves
Refer to page EN-66 for details.

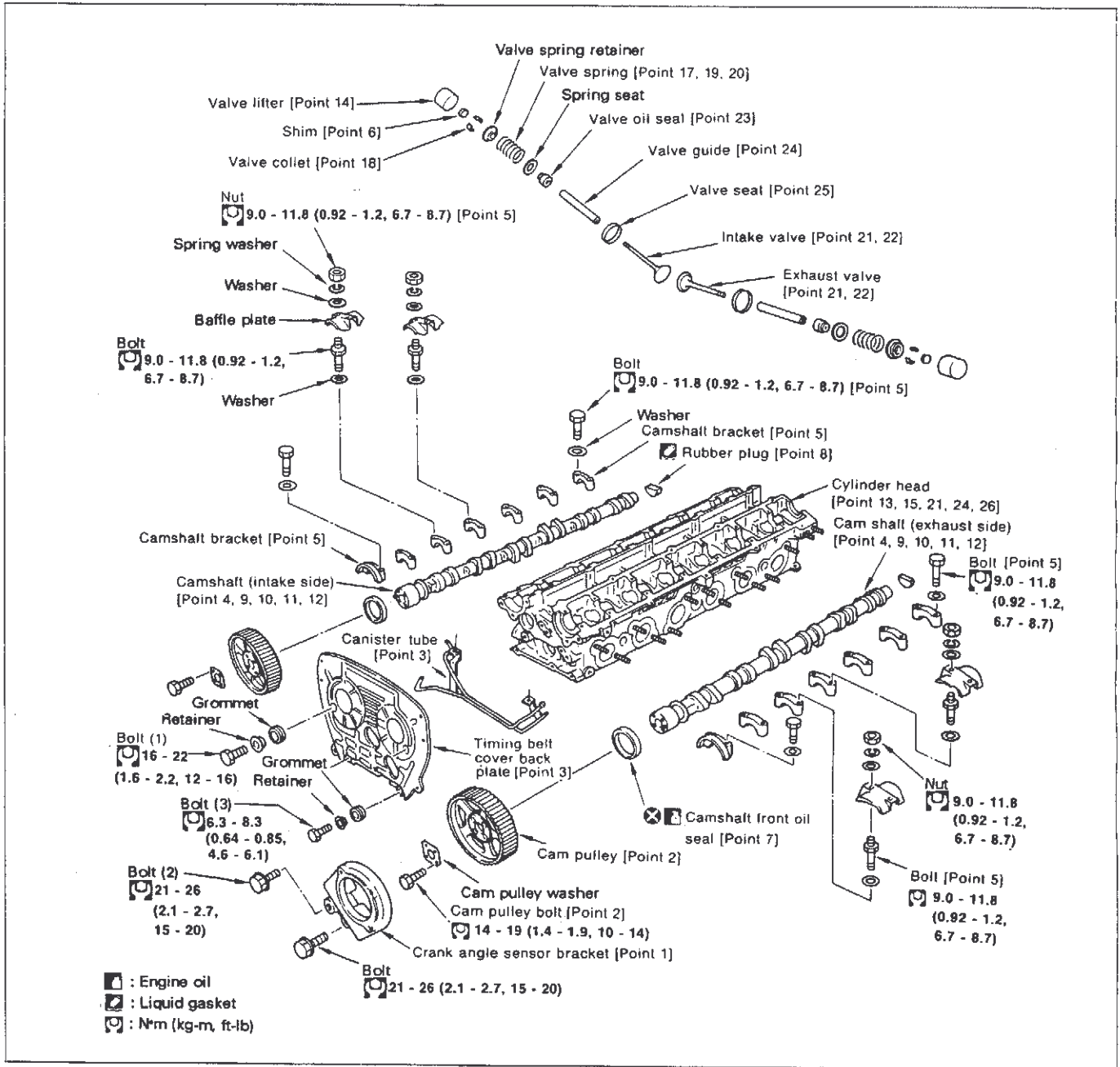

Additional work required:

● Cylinder head ASSY removal and installation

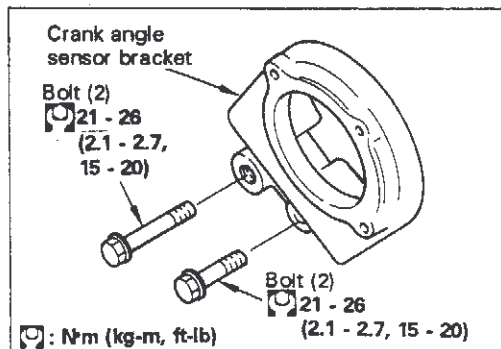

[Point 1] Crank angle sensor bracket installation

- The crank angle sensor bracket is positioned onto the cylinder head by using knock pins (2 locations). Align the positions correctly when installing the crank angle sensor.

Crank angle sensor bracket bolt tightening torque	21 - 26 N·m (2.1 - 2.7 kg-m, 15 - 20 ft-lb)
---	---

B2 RB26 DOHC EGI (ECCS) TWIN-TURBOCHARGER ENGINE

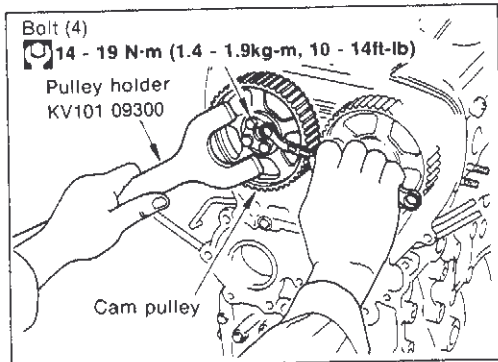

[Point 2] Cam pulley removal and installation

Removal

- Secure the pulley with a pulley holder or sprocket wrench and remove cam pulley bolts.

Pulley holder	KV101 09900 or [KV101 09300, ST3152 0000, or ST3153 0000]
---------------	--

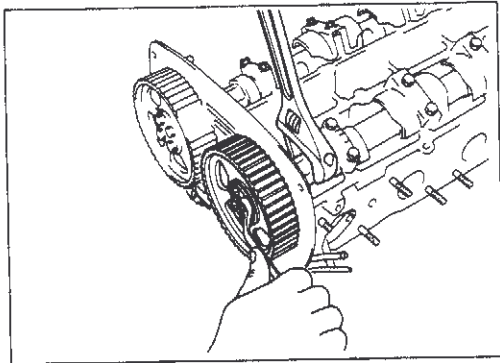

Installation

- Align camshaft knock pin and cam pulley knock pin holes to install camshaft pulley.
- Use a pulley holder or sprocket wrench to tighten the cam pulley bolt.

Cam pulley bolt tightening torque	14 - 19 N·m (1.4 - 1.9 kg·m, 10 - 14 ft·lb)
-----------------------------------	---

- To remove and install cam pulley bolts, use the proper tool to secure the hexagonal part in front of camshaft.

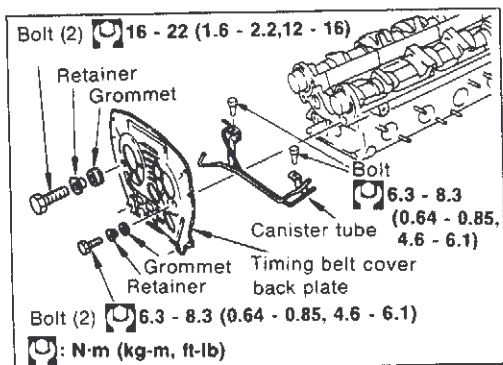

[Point 3] Timing belt cover back plate removal and installation

Removal

- Remove back plate bolts and detach back plate.

Installation

- Assemble back plate with canister tube and then install back plate.

Back plate bolt tightening torque	M6	6.3 - 8.3 (0.64 - 0.85, 4.6 - 6.1)
	M8	16 - 21 (1.6 - 2.1, 12 - 15)

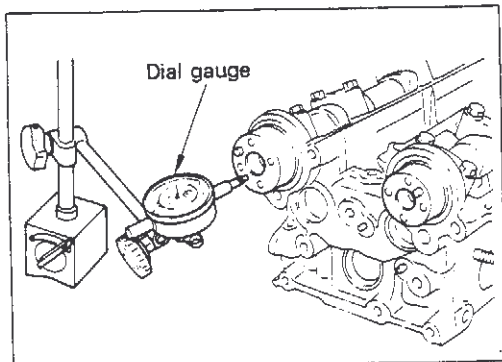

[Point 4] Camshaft end play inspection

- Set a dial gauge at front end of camshaft in thrust direction. When camshaft moves in front and rear direction, read the dial gauge runout width.

Standard value	0.030 - 0.080 mm (0.0012 - 0.0031 in)
----------------	---------------------------------------

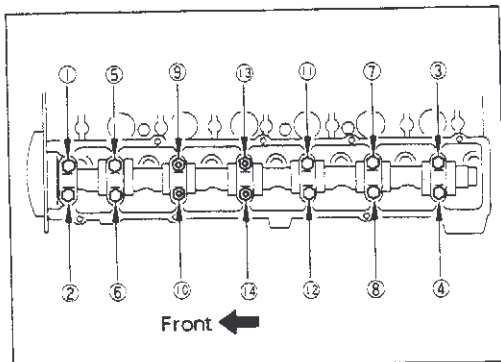

[Point 5] Camshaft bracket removal and installation

Removal (intake and exhaust camshafts)

- Before removing camshaft bracket, paint marks to indicate bracket position and direction.
- Remove cam bracket bolts by loosening them gradually in several stages, in reverse sequence shown in left figure.

B2 RB26 DOHC EGI (ECCS) TWIN-TURBOCHARGER ENGINE

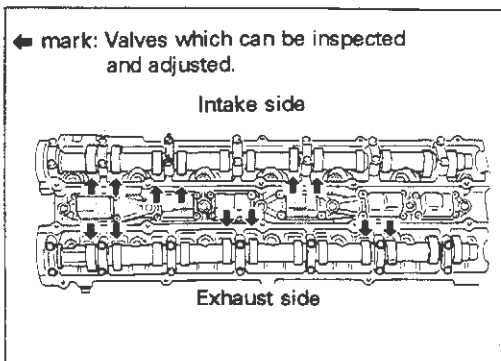
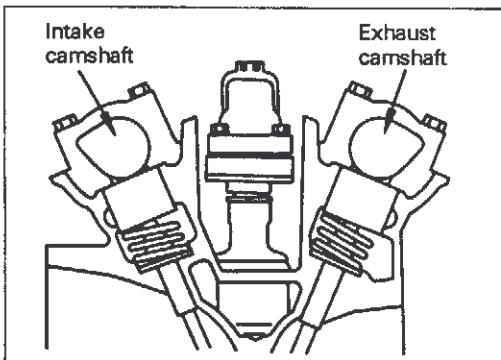
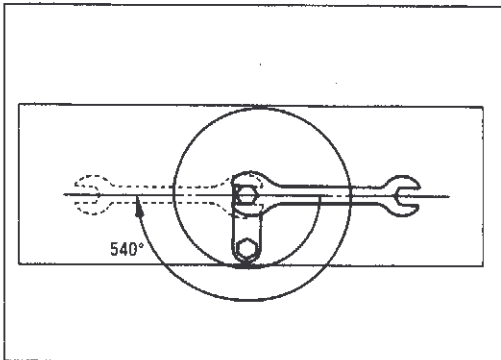
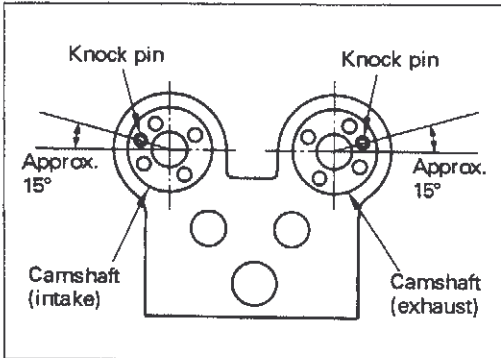
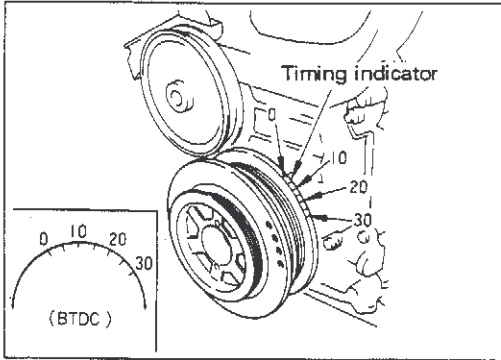

Installation

- Align crank pulley timing mark and timing belt cover timing indicator (0°) so No. 1 cylinder is at compression T.D.C. position. (This operation is not necessary when cylinder head is removed as single unit.)
- Turn camshaft so No. 1 cylinder is at compression T.D.C. position. (Operation is easier if the camshaft is turned 60° before or after No. 1 cylinder T.D.C. point when cylinder head is installed as single unit.) Verify position of No. 1 cylinder is at compression T.D.C. by knock pin in front end of camshaft.
- To install camshaft, temporarily tighten No. 1 cam bracket and check that camshaft thrust section is positioned securely.
- Tighten cam shaft bolt 540° (1.5 turns) in the numeric order shown in upper left figure.

Cam bracket tightening torque

9.0 - 11.8 N·m (0.92 - 1.2 kg-m, 6.7 - 8.7 ft-lb)

CAUTION:

- Before installation, coat the cam journals and end of camshaft with engine oil.
- Do not rotate camshaft. (The valves and pistons may interfere.)

[Point 6] Valve clearance adjustment

No. 1 cylinder compression T.D.C. point

- Turn camshafts (intake and exhaust) so No. 1 cylinder is at the compression T.D.C. position.
 - Check knock pin position of camshaft front end to verify No. 1 cylinder compression T.D.C. position.
- No. 1 cylinder is at compression stroke top dead center when both the intake and exhaust side cams do not move the valve lifters.

Item	Part	Valve clearance measurement
Intake side		Cylinder No. 1, 2, 4
Exhaust side		Cylinder No. 1, 3, 5

Firing order: 1-5-3-6-2-4

B2 RB26 DOHC EGI (ECCS) TWIN-TURBOCHARGER ENGINE

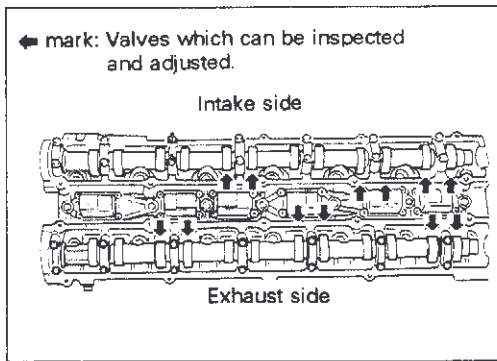

- Rotate intake and exhaust camshafts 180°.
- No. 6 cylinder is at compression stroke top dead center when both the intake and exhaust side cams do not move the valve lifters.

Item	Part	Valve clearance measurement
Intake side		Cylinder No. 3, 5, 6
Exhaust side		Cylinder No. 2, 4, 6

Valve clearance specifications

[20 ± 5°C (68 ± 9°F)]

Item	Part	Intake	Exhaust
Valve clearance (cold)		0.45 ± 0.03	0.38 ± 0.03
mm (in)		(0.018 ± 0.001)	(0.015 ± 0.001)
(Reference value: hot)		0.51 ± 0.03	0.44 ± 0.03
mm (in)		(0.020 ± 0.001)	(0.017 ± 0.001)

CAUTION:

Always inspect when engine is cold.

Reference: Compensation by room temperature

Room temperature	0 ± 5 (32 ± 9)	10 ± 5 (50 ± 9)	20 ± 5 (68 ± 9)	30 ± 5 (86 ± 9)
°C (°F)				
Compensation value	+0.02	+0.01	0 (0)	-0.01
mm (in)	(+0.0008)	(+0.0004)		(-0.0004)

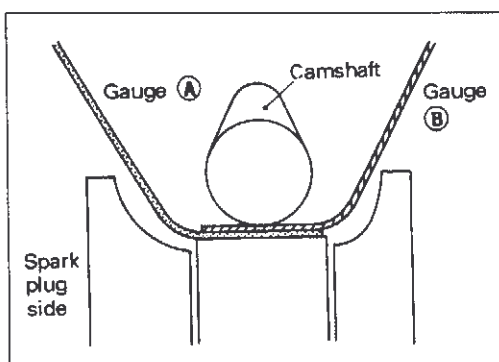

Valve clearance measurement method

- Insert a 0.15 to 0.20 mm (0.0059 to 0.0079 in) feeler gauge (A) from spark plug side.
- Insert feeler gauge(s) (B) from opposite side. Select a gauge thickness that will reduce the clearance to 0 mm (0 in).

Note:

- Do not use more than two gauges for (B).
- The feeler gauge must conform to JIS (Japanese Industrial Standard) 150A25.

Valve clearance = gauge (A) + gauge (B)

Reasons for measurement using gauges (A) and (B)

- ① The valve clearance setting is larger compared to previous engines.
 - ② The gauges cannot be placed parallel to the measurement surface due to the structure.
- The blade of thick gauges has a high rigidity and does not bend easily, resulting in a large measurement error.
 - The error increases if a number of thin gauges are layered and the measurement will be incorrect.

B2 RB26 DOHC EGI (ECCS) TWIN-TURBOCHARGER ENGINE

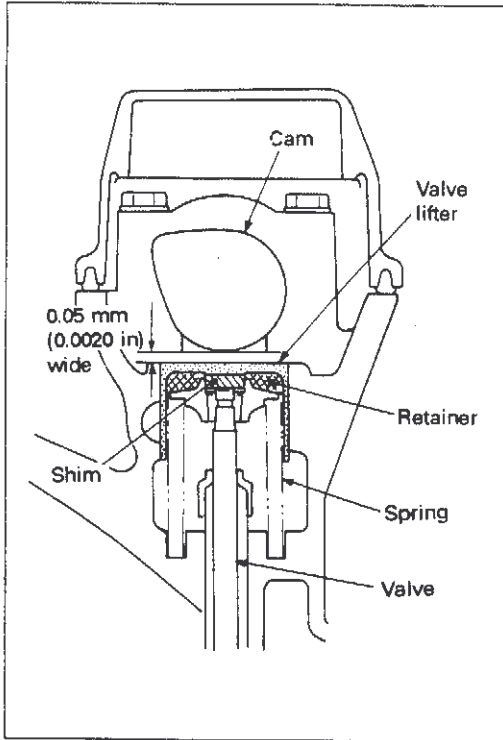

Valve clearance adjustment

- Select the shim for the valve clearance.
- When measured valve clearance (t) does not conform to specified value, measure shim thickness (T) and replace it with a shim that will produce the standard clearance.

① Shim thickness calculation method

Example: When intake valve clearance (t) is 0.50 mm (0.020 in):
 $0.50 (t) - 0.45 (\text{specified value}) = 0.05 \text{ mm (0.0020 in)}$.

- The valve clearance is 0.05 mm (0.0020 in) greater than specified value.
- Use shim 0.05 mm (0.0020 in) thicker than current thickness to narrow valve clearance.

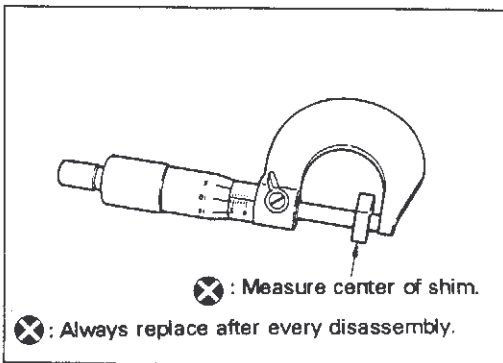

② Current shim thickness (T) measurement method

- Use micrometer and measure center of shim.

CAUTION:

Dispose of shims which have been measured and do not use them again.

③ Shim selection

- When current shim thickness (T) is 2.40 mm (0.0945 in): $2.40 (T) \text{ mm (0.0945 in)} + 0.05 \text{ mm (0.0020 in)} = 2.450 \rightarrow$ selected shim thickness
- Read the identification mark $[\frac{24}{40}]$ (T: 2.440 to 2.455) to select shim closest to required thickness.

CAUTION:

The shim thickness tolerance is $\pm 0.03 \text{ mm (0.0012 in)}$.

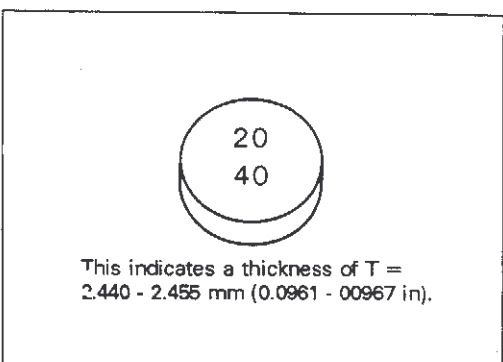

④ Identify the shim type

- There are 70 different types of shims. Sizes range from 2.275 mm (0.0896 in) to 3.325 mm (0.1309 in) in 0.015 mm (0.0006 in) increments.
- After installing camshaft, measure valve clearance again to check that clearance is within specifications.

B2 RB26 DOHC EGI (ECCS) TWIN-TURBOCHARGER ENGINE

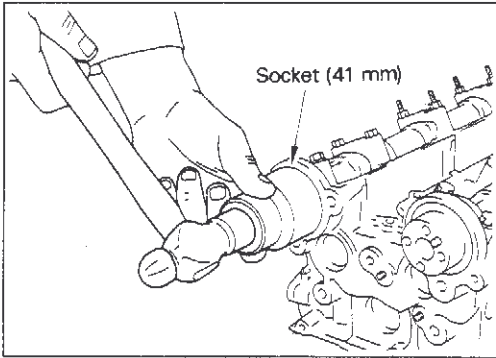

[Point 7] Camshaft front oil seal installation

- Be careful not to scratch or make a burr in the oil seal. Use a socket smaller than the seal (41 mm) and drive it into same level as front surface of oil seal retainer.
- Apply a coat of engine oil to the entire perimeter of oil seal lip.

CAUTION:

Do not scratch the oil seal and lip.

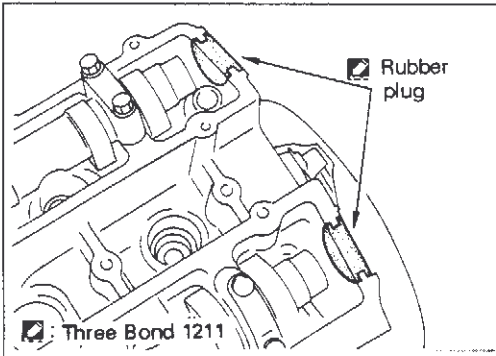

[Point 8] Camshaft rear rubber plug installation

- Before installing rubber plug, remove oil, water, etc., on surface and clean thoroughly.
- When assembling rubber plug, coat it with adhesive (Three Bond 1211).

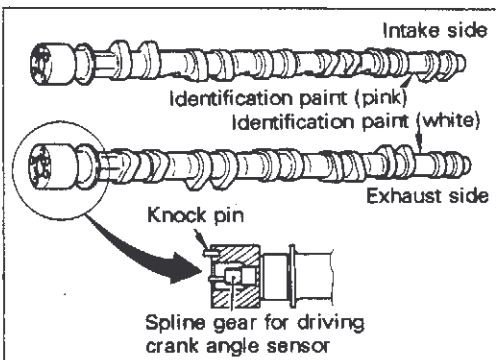

[Point 9] Intake and exhaust camshaft classification

- Intake and exhaust camshafts can be identified by identification paint color and presence of a spline gear for driving the crank angle sensor.

Camshaft	Identification paint	Spline gear
Intake camshaft	Pink	No
Exhaust camshaft	White	Yes

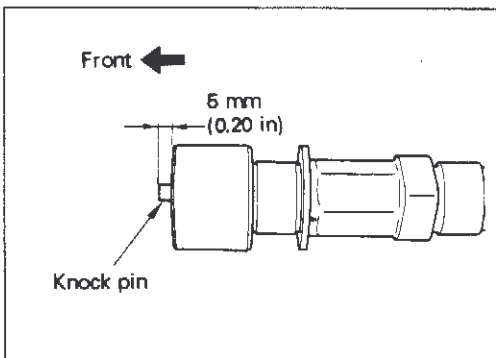

[Point 10] Camshaft knock pin insertion

- The protrusion distance is 5 mm (0.20 in) for camshaft knock pin insertion.

Knock pin protrusion distance	5 mm (0.20 in)
-------------------------------	----------------

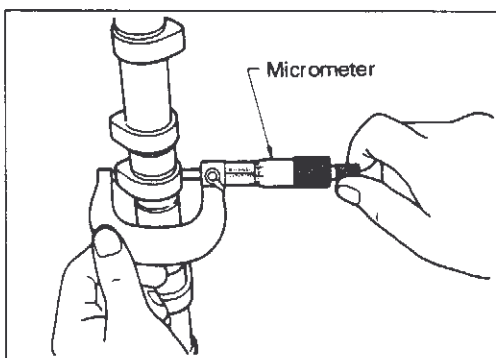

[Point 11] Camshaft inspection

Cam height inspection

- Use a micrometer to measure cam height.

Unit: mm (in)

	Intake side	Exhaust side
Cam height standard value	40.58 (1.5976)	40.28 (1.5858)
Cam lift (reference)	8.58 (0.3378)	8.28 (0.3260)

B2 RB26 DOHC EGI (ECCS) TWIN-TURBOCHARGER ENGINE

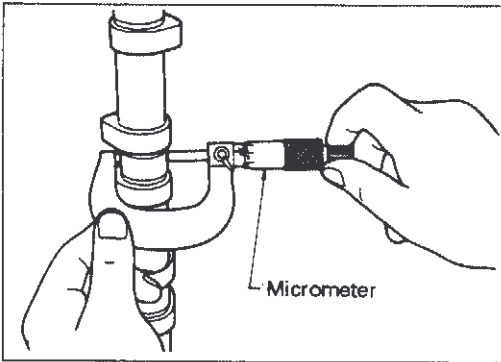

Camshaft journal outside diameter inspection

- Use micrometer to measure outside diameter of camshaft journal.

	No. 1 - No. 7
Standard value	27.935 - 27.955 mm (1.0998 - 1.1006 in)

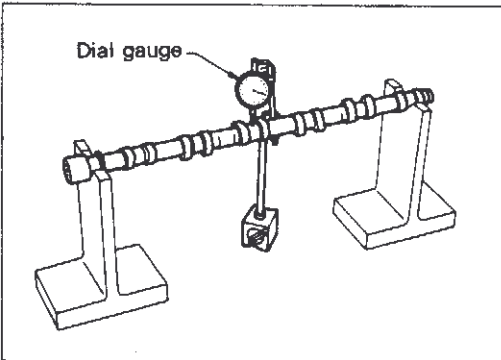

[Point 12] Camshaft runout inspection

- Use V-blocks on fixed surface to support both camshaft end journals (No. 1 and No. 7).
- Avoid the oil groove in the center of the No. 4 journal and position the dial gauge vertically.
- Turn the camshaft by hand one rotation and read the movement width on dial gauge.
- The runout is equal to one-half of the movement width indicated on dial gauge.

Standard value	0.05 mm (0.0020 in)
----------------	---------------------

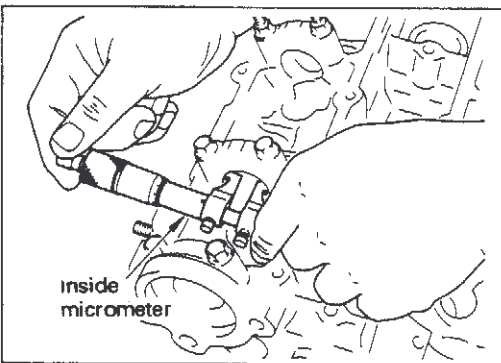

[Point 13] Cylinder head cam bracket inside diameter inspection

- Tighten the cam bracket to specified torque.

Cam bracket bolt tightening torque	9.0 - 11.8 N·m (0.92 - 1.2 kg-m, 6.7 - 8.7 ft-lb)
------------------------------------	---

- Use bore gauge or inside micrometer to measure inside diameter.

	No. 1 - No. 7
Standard value	28.000 - 28.021 mm (1.1024 - 1.1032 in)

[Point 14] Camshaft oil clearance inspection

- The oil clearance can be calculated from the camshaft journal outside diameter and bracket inside diameter measured in [Point 11] and [Point 13].
(Clearance) = (cam bracket inside diameter) - Camshaft journal (outside diameter)

	No. 1 - No. 7
Standard value	0.045 - 0.086 mm (0.0018 - 0.0034 in)

B2 RB26 DOHC EGI (ECCS) TWIN-TURBOCHARGER ENGINE

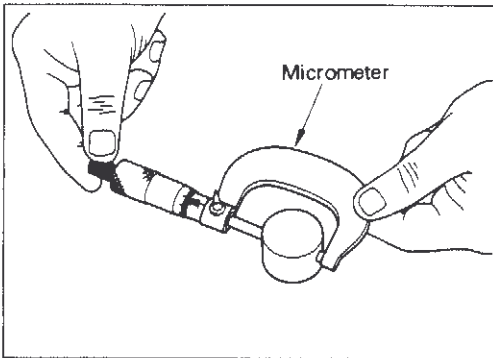

[Point 15] Valve lifter inspection

- Check contact and sliding surfaces for wear or scratches. Replace if damaged.
- Use a micrometer to check the valve lifter outside diameter.

Standard value	30.955 - 30.965 mm (1.2187 - 1.2191 in)
----------------	---

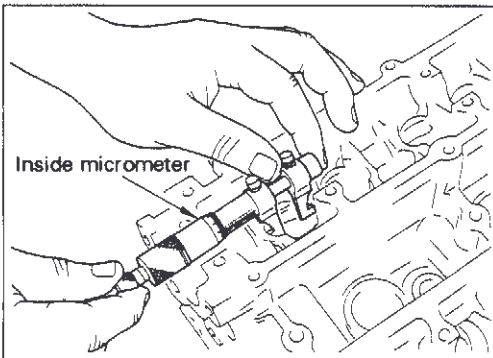

[Point 16] Cylinder head lifter bore inspection

- Check bore surface for wear or scratches.
- Use inside micrometer to measure valve lifter hole diameter.

Standard value	31.0 - 31.020 mm (1.2205 - 1.2213 in)
----------------	---------------------------------------

[Point 17] Valve lifter-to-lifter hole clearance inspection

- Check the clearance using values for the valve lifter outside diameter and valve lifter hole diameter measured in [Point 15] and [Point 16].
(Clearance) = (valve lifter hole diameter) - (valve lifter outside diameter)

Standard value	0.025 - 0.065 mm (0.0010 - 0.0026 in)
----------------	---------------------------------------

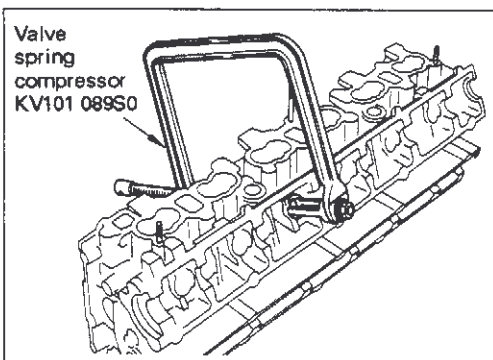

[Point 18] Valve spring removal and installation

When cylinder head is removed from vehicle:

- Use valve spring compressor (KV101 089S0) to remove and install valves.

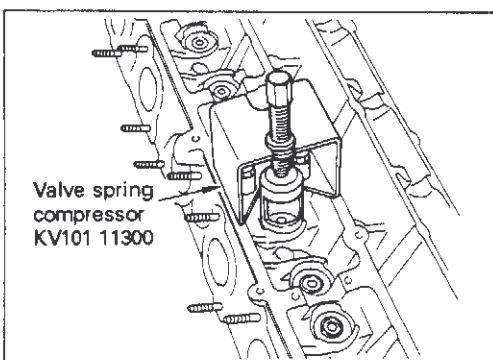

When cylinder head is installed in vehicle.

- Use valve spring compressor (KV101 11300) to remove and install valve springs.

B2 RB26 DOHC EGI (ECCS) TWIN-TURBOCHARGER ENGINE

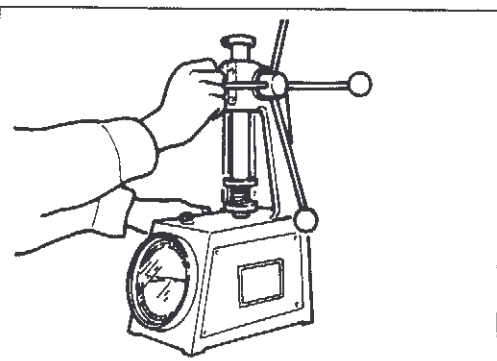
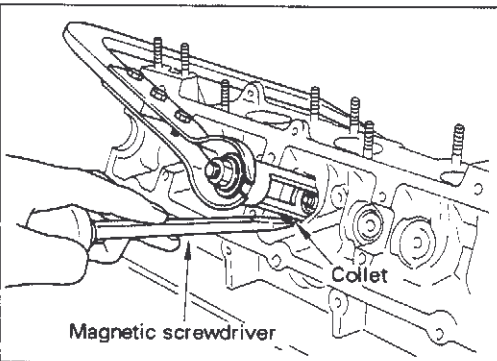
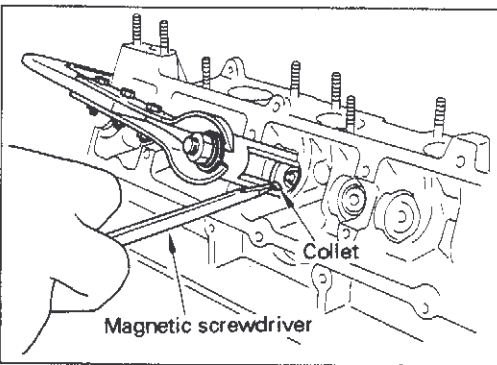

[Point 19] Valve collet removal and installation

Removal

- Use tweezers for removal and installation of collet.

Installation

- Apply a small coating of petroleum jelly to the internal surface of collet.
- Use a magnetic screwdriver.
 - ① Upper collet installation
Attach collet to lower side of magnetic screwdriver blade and install in the valve stem.
 - ② Lower collet installation
Attach collet to upper side of magnetic screwdriver blade and install in the valve stem.

[Point 20] Valve spring inspection

Free length and pressure load inspection

- Use a valve spring tester to check spring pressure.

	Standard value	Limit value
Free length mm (in)	46.54 (1.8323)	—
Installation load N (kg, lb)	235.4 (24.0, 52.9)	220.7 (22.5, 49.6)
identification color	White	—

Note: Installation load is the force required to compress the spring to a 35 mm (1.38 in) length.

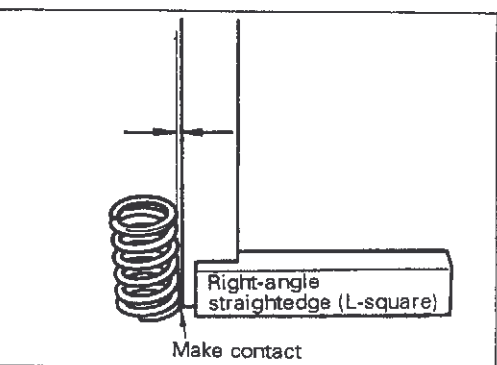

Valve spring squareness inspection

- Place a right-angle straightedge (L-square, etc.) so it contacts spring. Turn spring and measure the maximum clearance between upper spring surface and right angle surface to determine out-of-square distance.

Limit	1.8 mm (0.071 in)
-------	-------------------

B2 RB26 DOHC EGI (ECCS) TWIN-TURBOCHARGER ENGINE

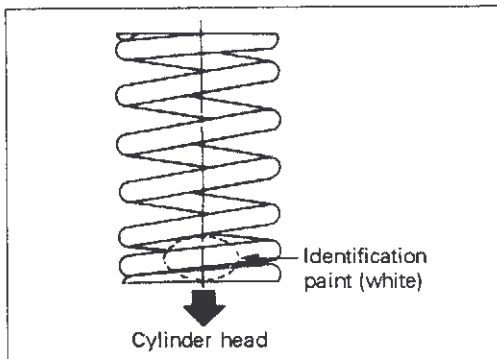

[Point 21] Valve spring installation

- Install uneven pitch type spring with narrow pitch end toward cylinder head (identification color side down).

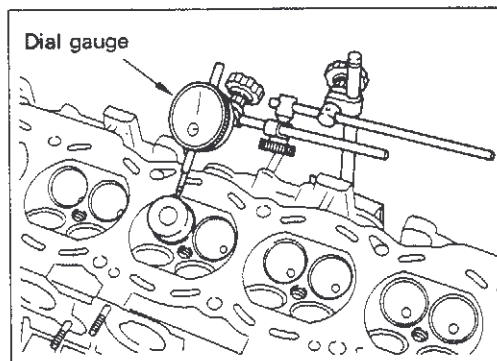

[Point 22] Valve guide clearance inspection

- Protrude valve approximately 15 mm (0.59 in) from valve guide hole into combustion chamber. Measure valve deflection by swinging it in direction parallel to dial gauge.
- The clearance is equal to one-half of the dial gauge reading (deflection width).

		Intake	Exhaust
Limit	mm (in)	0.1 (0.004)	0.1 (0.004)

- If clearance exceeds limit, verify valve stem diameter and replace valve or valve guide.

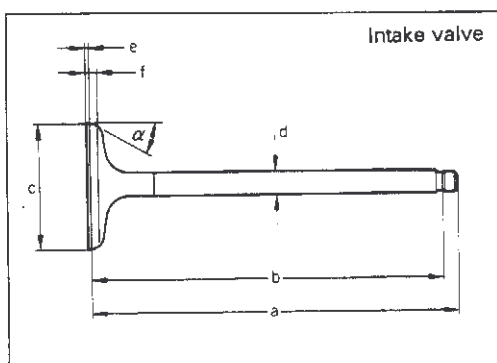

[Point 23] Valve inspection

Outside diameter measurement

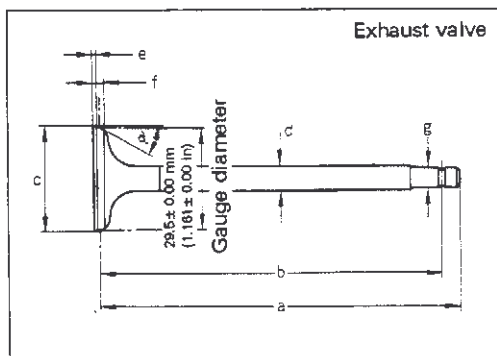

B2 RB26 DOHC EGI (ECCS) TWIN-TURBOCHARGER ENGINE

Unit : mm (in)

Valve	a	b	c	d	e	f	g	α
Intake	100.98 ± 0.1 (3.9756 ± 0.0039)	97.45 ± 0.15 (3.8366 ± 0.0059)	34.5 ^{+0.2} ₀ (1.358 ^{+0.008} ₀)	6.0 ^{-0.020} _{-0.035} (0.2362 ^{-0.0008} _{-0.0014})	1.3 (0.051)	2.6 ^{+0.3} ₀ (0.102 ^{+0.012} ₀)	—	45°30'
Exhaust	99.98 ± 0.1 (3.9362 ± 0.0039)	95.48 ± 0.15 (3.7590 ± 0.0059)	30.0 ^{+0.2} ₀ (1.181 ^{+0.008} ₀)	7.0 ^{-0.080} _{-0.095} (0.2756 ^{-0.0031} _{-0.0037})	1.2 (0.047)	2.9 ^{+0.3} ₀ (0.114 ^{+0.012} ₀)	6.0 ^{-0.020} _{-0.055} (0.236 ^{-0.0008} _{-0.0022})	45°30' ± 15'

Be especially careful in handling and disposal of valves because exhaust valves are filled with metallic sodium. Refer to Page EN-67.

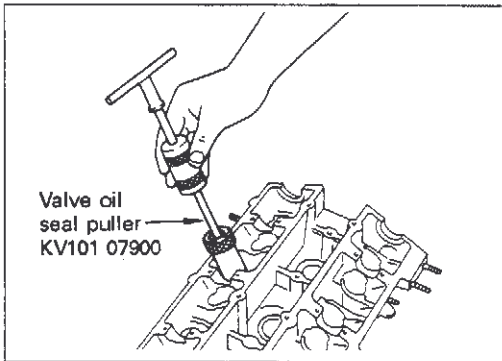

[Point 24] Valve oil seal removal and installation

Removal

- Use valve oil seal puller to remove valve seal.

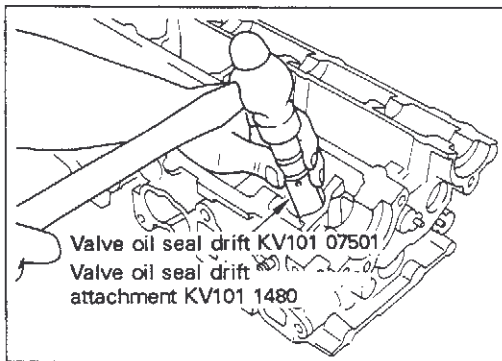

Installation

- Use valve oil seal drift to install valve seals.

Tools	Part	Intake	Exhaust
Drift		KV101 07501	
Drift attachment		KV101 14800	

CAUTION:

Coat inside of valve oil seal with engine oil before installation.

- Install valve oil seal as shown in figure.

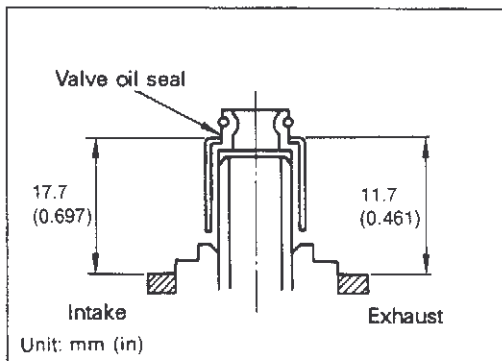

[Point 25] Valve guide removal and installation

Removal

- Use valve guide drift and tap it from combustion chamber side to remove seal.

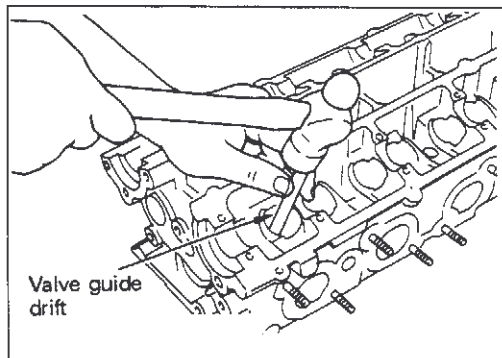

B2 RB26 DOHC EGI (ECCS) TWIN-TURBOCHARGER ENGINE

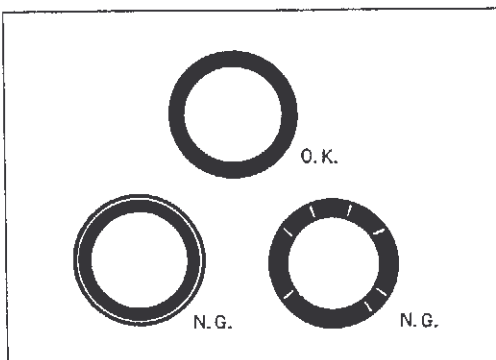
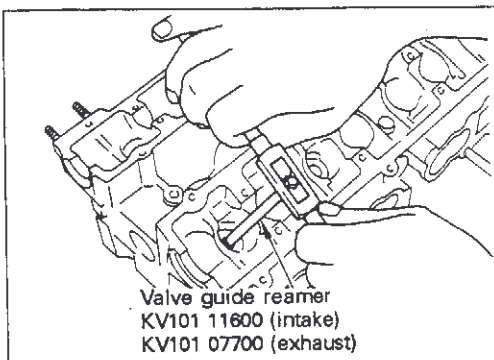
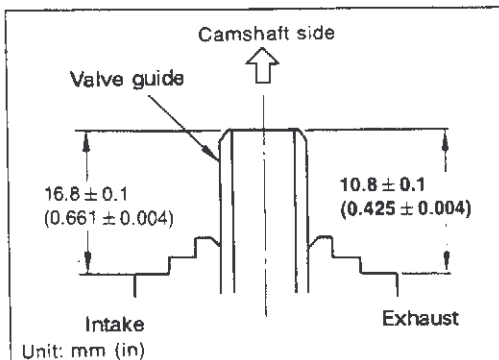
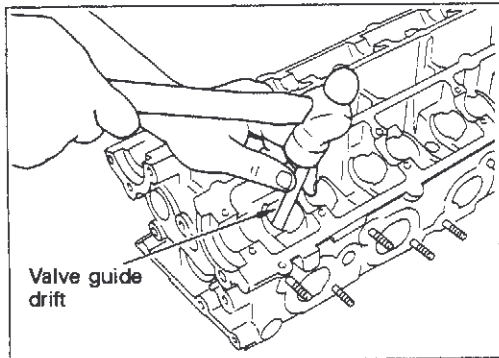
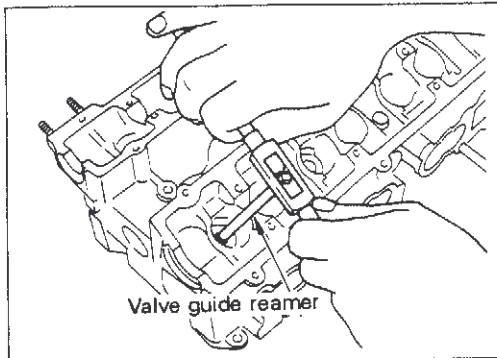

Installation

- Ream cylinder head valve guide holes with valve guide reamer at normal temperature to rectify the hole diameter [when using 0.5 mm (0.020 in) oversize service part].

Rectified value mm (in)	Intake side	10.46 - 10.478 (0.4118 - 0.4125)
	Exhaust side	11.46 - 11.478 (0.4512 - 0.4519)

- Heat cylinder head in an oil bath to approximately 150 to 160°C (302 to 320°F). Use a valve guide drift or press-fit tool and press valve guide from camshaft side.

- The press-fit dimensions are shown in figure at left.

- Ream the inside of the inserted valve guide with valve guide reamer.

Finished internal diameter standard value mm (in)	Intake side	6.000 - 6.018 (0.2362 - 0.2369)
	Exhaust side	7.000 - 7.018 (0.2756 - 0.2763)

[Point 26] Valve seat

Inspection

- Check contacting surfaces of valve seat and valve.
- Replace valve or valve seat if contacting surface is too large or improper, or grind both surfaces and lap with abrasive compound.

B2 RB26 DOHC EGI (ECCS) TWIN-TURBOCHARGER ENGINE

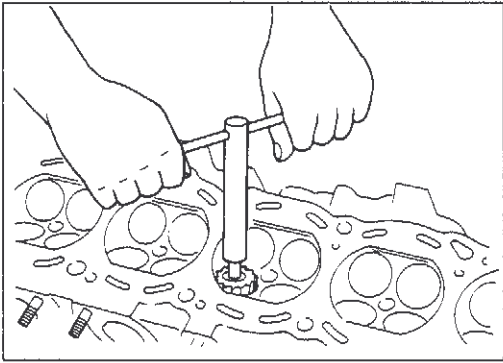

- When surfacing valve seat due to poor contact, inspect valve guide clearance and valve stem hole clearance.
- Use valve seat cutter or valve seat grinder and finish to standard value.

CAUTION:

When using valve seat cutter, press firmly and cut evenly with both hands to produce uniform cutting surface.

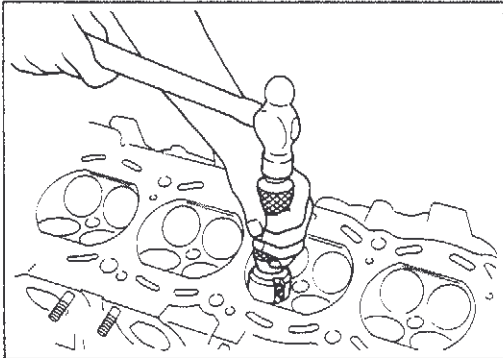

Removal

- Minimize valve seat thickness by cutting it, then remove.

Installation

- ① Drive valve seat into cylinder head using valve seat as shown in figure.

- Exhaust valve seats are available in 0.5 mm (0.020 in) over size. When using oversize valve seats, cut and grind seat ing recess in cylinder head to fix valve seats.

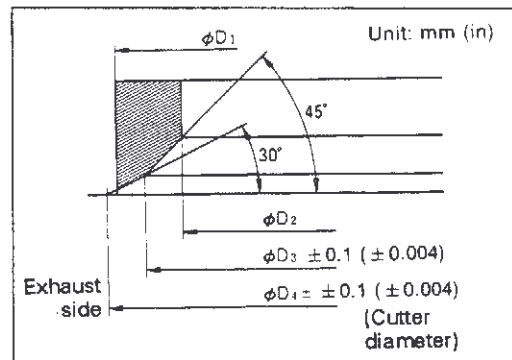
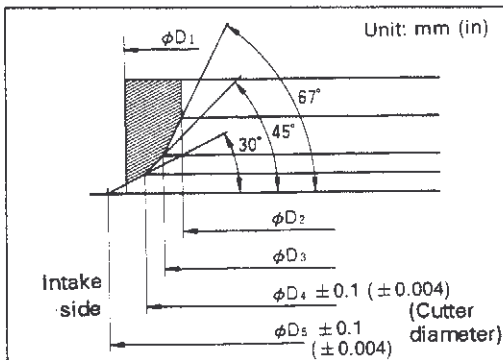

Unit: mm (in)

Valve oversize		Item	Cylinder head finishing					Valve seat	
			ϕd	ϕD_1	ϕD_2	ϕD_3	ϕD_4	ϕD_5	H
Intake	Standard	$36 \begin{smallmatrix} +0.016 \\ 0 \\ (1.4173 \pm 0.0006) \end{smallmatrix}$	$36 \begin{smallmatrix} +0.113 \\ +0.097 \\ (1.4173 \pm 0.0044) \end{smallmatrix}$	30 ± 0.15 (1.1811 ± 0.0059)	32 (1.26)	34.3 (1.358)	37.5 (1.476)	$6.6 \begin{smallmatrix} 0 \\ 0.1 \\ (0.260 \pm 0.004) \end{smallmatrix}$	
	0.5 (0.020)	$36.5 \begin{smallmatrix} +0.016 \\ 0 \\ (1.4370 \pm 0.0006) \end{smallmatrix}$	$36.5 \begin{smallmatrix} +0.113 \\ +0.097 \\ (1.4370 \pm 0.0044) \end{smallmatrix}$	30 ± 0.15 (1.1811 ± 0.0059)	32 (1.26)	34.3 (1.358)	—	5.8 ± 0.05 (0.2283 ± 0.0020)	
Exhaust	Standard	$32 \begin{smallmatrix} +0.016 \\ 0 \\ (1.2598 \pm 0.0006) \end{smallmatrix}$	$32 \begin{smallmatrix} +0.096 \\ +0.080 \\ (1.2598 \pm 0.0038) \end{smallmatrix}$	25 ± 0.15 (0.9843 ± 0.0059)	29.6 (1.165)	32.5 (1.280)	—	$6.6 \begin{smallmatrix} 0 \\ 0.1 \\ (0.260 \pm 0.004) \end{smallmatrix}$	
	0.5 (0.020)	$32.5 \begin{smallmatrix} +0.016 \\ 0 \\ (1.2795 \pm 0.0006) \end{smallmatrix}$	$32.5 \begin{smallmatrix} +0.096 \\ +0.080 \\ (1.2795 \pm 0.0038) \end{smallmatrix}$	25 ± 0.15 (0.9843 ± 0.0059)	29.6 (1.165)	—	—	5.8 ± 0.05 (0.2283 ± 0.0020)	

B2 RB26 DOHC EGI (ECCS) TWIN-TURBOCHARGER ENGINE

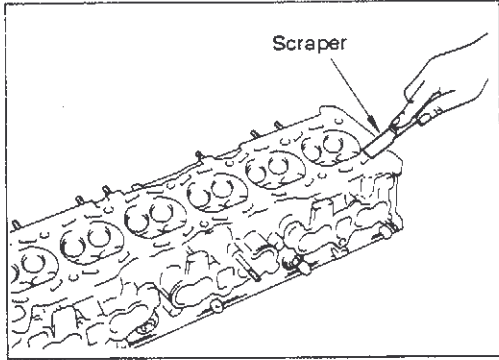

[Point 27] Cylinder head inspection

- Remove all traces of oil, fur, gasket, sealing compound, carbon, and other foreign matter from cylinder head surface.

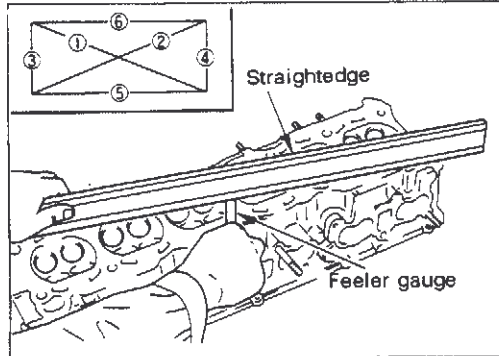

- Measure lower surface of cylinder head in six directions to check for distortion.

Limit	0.2 mm (0.008 in)
-------	-------------------

- When distortion is within the limit, resurface the cylinder head.
- If distortion exceeds the limit, replace cylinder head.

10-13 WATER PUMP REMOVAL AND INSTALLATION

Tools required

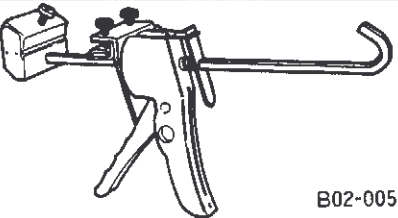
	Name		Application
Tool	Tube presser WS3993	 <p style="text-align: right;">B02-0051</p>	Liquid gasket application

B2 RB26 DOHC EGI (ECCS) TWIN-TURBOCHARGER ENGINE

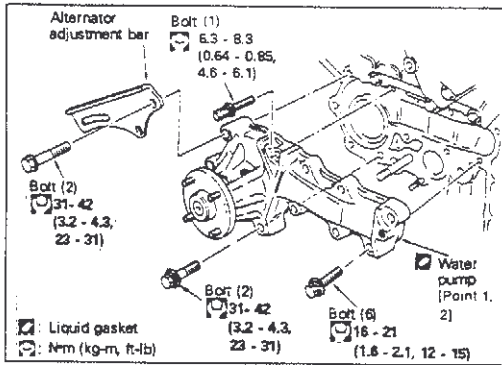

Additional work required:

- Drain and refill cooling water. (Refer to section B6, 3.)
- Remove and install:
Cooling fan, water pump pulley
Alternator adjustment bolt
Timing belt cover, timing belt

CAUTION:

Loosen engine drain plug to remove cooling water from cylinder block.

(If water is only drained from the radiator drain cock, the cylinder block will not drain completely.)

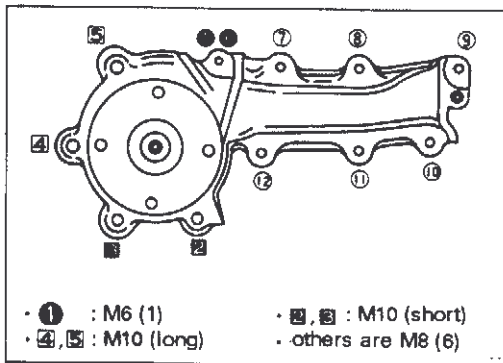

[Point 1] Water pump removal and installation

Removal

- When removing water pump assembly, be careful not to get coolant on timing chain. If any water does spill, wipe it off immediately.
- Remove water pump bolts in the reverse of sequence in figure on left.

Installation

- Install bolts in the numbered sequence in figure on left.

Installation location	Bolt size	Number of bolts	Tightening torque N·m (kg-m, ft-lb)
①	M6	1	6.3 - 8.3 (0.64 - 0.85, 4.6 - 6.1)
⑦, ⑧, ⑨, ⑩, ⑪, ⑫	M8	6	16 - 21 (1.6 - 2.1, 12 - 15)
②, ③, ④, ⑤	M10	4	31 - 42 (3.2 - 4.3, 23 - 31)

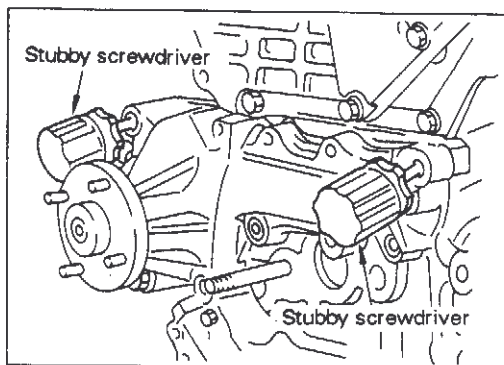

Removal and cleaning

- Insert stubby screwdrivers in bolt holes as shown, and move them up and down to remove water pump.

CAUTION:

Be careful not to damage screws in cylinder block side.

- Use a scraper to remove all traces of liquid gasket from mating surface.

CAUTION:

Also remove any liquid gasket remaining in grooves.

- Clean installation surface with white gasoline.

B2 RB26 DOHC EGI (ECCS) TWIN-TURBOCHARGER ENGINE

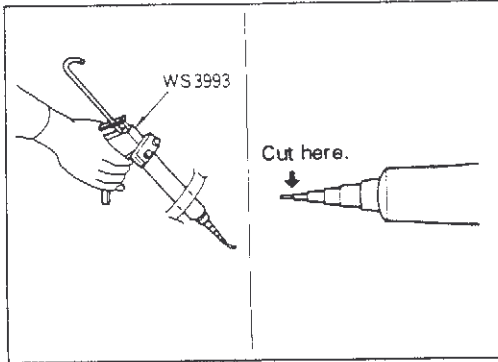

Apply a continuous bead of liquid gasket 2.0 to 3.0 mm (0.079 to 0.118 in) wide along the groove of installation surface. In sections where there is no groove around bolt hole, coat middle of inside seal surface.

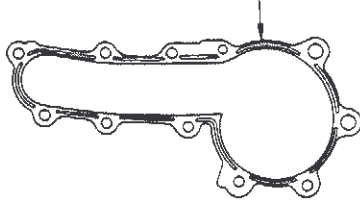

B02-3177

Installation

- Cut nozzle end of liquid gasket tube (KP510 00150) as shown in figure and use tube presser for application.

- Apply a continuous bead of liquid gasket (KP510 00150) to water pump sealing surface.

CAUTION:

- (1) Be sure liquid gasket is 2.0 to 3.0 mm (0.079 to 0.118 in) wide.
- (2) Installation should be done within 5 minutes after liquid gasket application.

[Point 2] Water pump inspection

- Rotate water pump by hand and check for abnormal sound and smooth operation.
- There must be no traces of water leaks.

10-14 THERMOSTAT REMOVAL AND INSTALLATION

Tools required

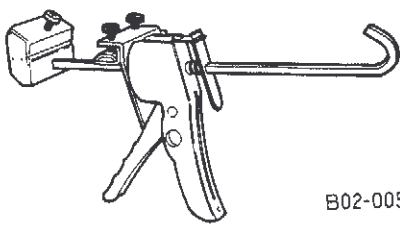
	Name	Application
Tool	Tube presser WS3993  B02-0051	Liquid gasket application
Measurement tool	Thermometer	Water temperature measurement

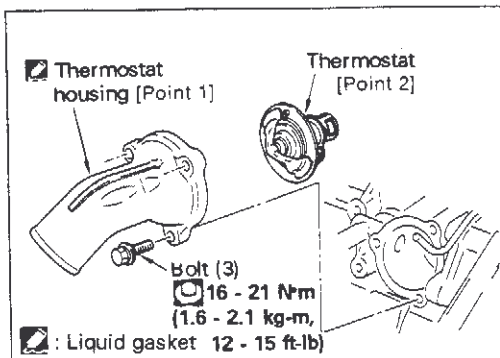

Additional work required:

- Drain and refill cooling water.

CAUTION:

Loosen engine drain plug to remove cooling water from cylinder block.

(If water is only drained from the radiator drain cock, the cylinder block will not drain completely.)

- Disconnect and connect water inlet hose.

B2 RB26 DOHC EGI (ECCS) TWIN-TURBOCHARGER ENGINE

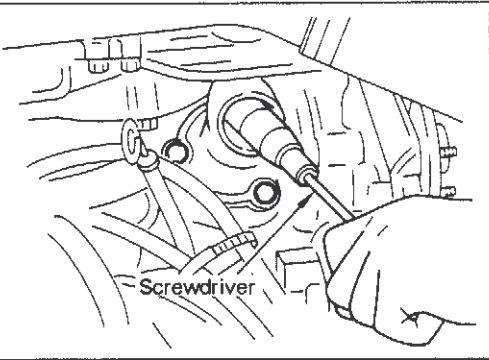

[Point 1] Thermostat housing removal and installation

Removal and cleaning

- Insert screwdriver handle into thermostat housing. Pry lightly up and down and remove housing.
- Use a scraper to remove the liquid gasket.

CAUTION:

Be sure to also remove liquid gasket in grooves.

- Clean mating surface with white gasoline or equivalent.

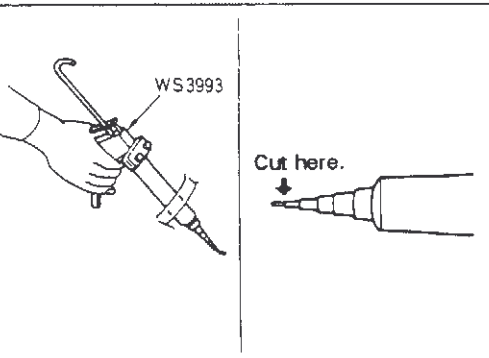

Installation

- Cut nozzle end of liquid gasket (KP510 00150) tube as shown in figure.

- Apply a continuous coat of liquid gasket (KP510 00150) to sealing surface using tube presser, and install the housing within 5 minutes after coating.

CAUTION:

Be sure liquid gasket is 2.0 to 3.0 mm (0.079 to 0.118 in) wide.

Tightening torque	16 - 21 N·m (1.6 - 2.1 kg-m, 12 - 15 ft-lb)
-------------------	---

Apply a continuous coat of liquid gasket 2.0 to 3.0 mm (0.079 to 0.118 in) wide to center of flat mating surface and inner sealing surfaces of bolt holes (if provided).

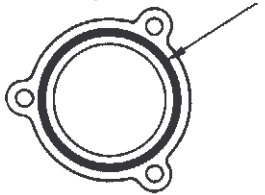

B02-3179

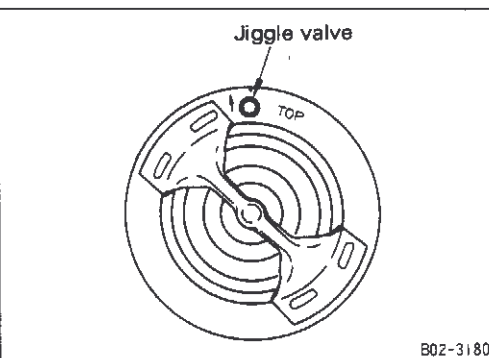

B02-3180

[Point 2] Thermostat installation

- "TOP" mark (jiggle valve) must face up when thermostat is inserted in housing.

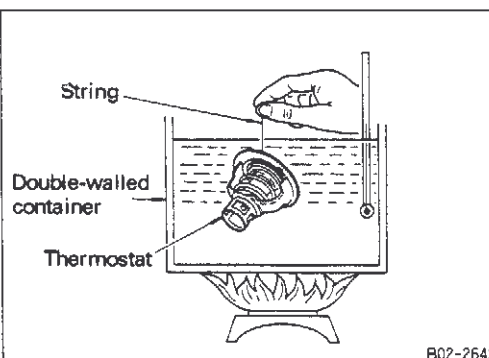

B02-2645

[Point 3] Thermostat inspection

- Check valve opening temperature and maximum valve lift.
- Hang thermostat by string in valve and submerge in heated water in double walled container and stir water while heating it up.
- The opening temperature is the temperature when the valve opens and thermostat falls from string.

		Standard, cooled location
Valve opening temperature	°C (°F)	76.5 (170)
Max. valve lift	mm (in)/°C (°F)	10 (0.39) min./90 (194)

B2 RB26 DOHC EGI (ECCS) TWIN-TURBOCHARGER ENGINE

10-15 OIL COOLER, OIL FILTER REMOVAL AND INSTALLATION

Tools required

	Name	Application
Special tool	Oil filter wrench KV101 062S0	Oil filter removal and installation

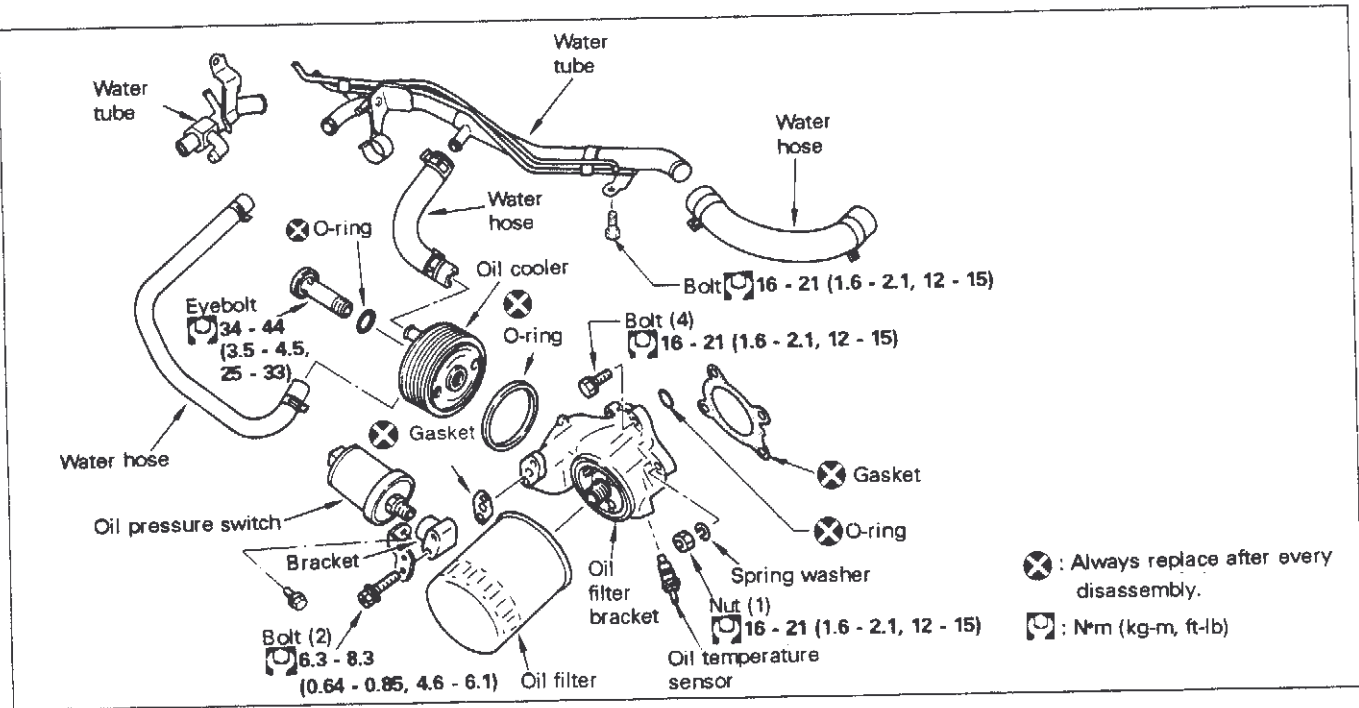
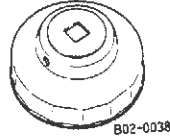

Additional work required:

- Drain and refill cooling water.

CAUTION:

Loosen engine drain plug to remove cooling water from cylinder block.
(If water is only drained from the radiator drain cock, the cylinder block will not drain completely.)

- Disconnect and connect switch harness connectors.

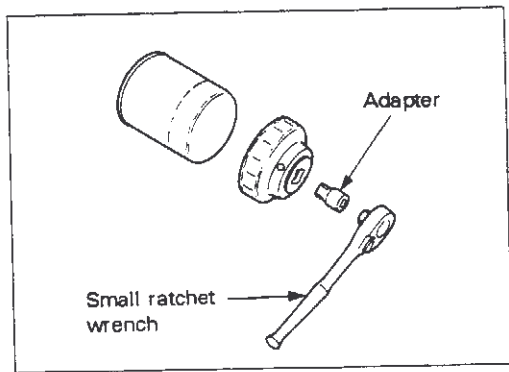

[Point 1] Oil filter removal and installation

Removal

1. Remove oil level gauge.
2. Remove turbocharged pressure control vacuum hose clamp and move vacuum hose out of the way.
3. Move main harness clamp out of the way.
4. Remove oil filter using oil filter wrench.

B2 RB26 DOHC EGI (ECCS) TWIN-TURBOCHARGER ENGINE

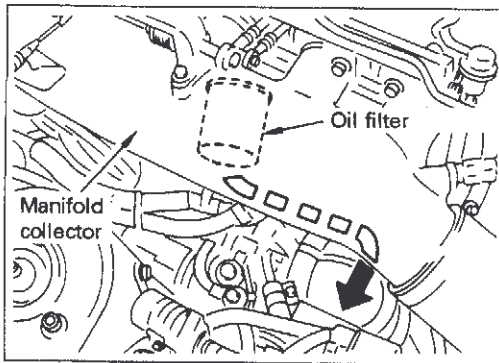

Installation

- Before installing new oil filter, wipe off dust, etc. from oil filter mounting bracket surface. Apply a thin coat of engine oil to oil filter O-ring.
- Screw oil filter on bracket by hand until a slight resistance is felt, then tighten an additional $2/3$ turn with oil filter wrench. After tightening, start engine and check for oil leaks.

Removal

- Face lower part of oil filter down and move out in direction of arrow in figure on left. Remove through aperture behind manifold collector.

11. Engine Removal and Installation

Basic items

This section describes how to use an engine hoist and transmission jack to remove and install the RB26DETT engine.

Additional work required:

Inspection and adjustment after installation

Position vehicle on a flat and solid surface.

Remove and install:

- Battery
- Engine hood
- Cooling water
- Radiator
- Starter motor
- Front drive shaft
- Transmission ASSY

Engine compartment left side:

- Exhaust gas sensor harness disconnection
- Ground line connector separation
- Power steering oil pump [Point 4].
- Air conditioning compressor [Point 4].
- Air inlet pump, air cleaner upper case

Engine compartment front side:

- Cooling fan

Engine compartment upper side:

- ECCS harness connectors

Engine compartment right side:

- Fuel feed, return hoses separation [Point 1].
- Accelerator cable separation [Point 2].
- Engine main harness and ground line separation [Point 3].
- Heater hose separation
- Vacuum hoses separation

Vehicle body, lower side:

- Engine under cover
- Front section of exhaust pipe separation
- Right and left engine mount brackets [Point 6, 7]
- Power steering oil tube separation [Point 5]

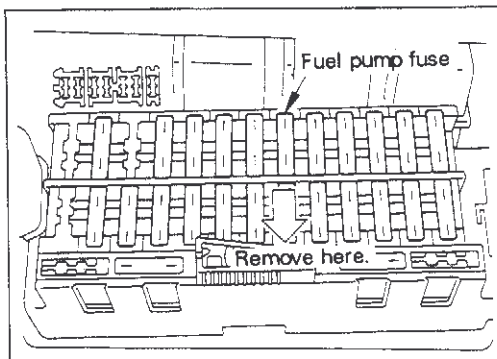

[Point 1] Release fuel pressure

- After starting engine, remove fuel pump fuse and run engine until it stops. Crank the engine over two or three times to consume fuel in fuel lines.
- When unable to start vehicle, remove fuel pump fuse and crank engine four to five times to consume fuel in fuel lines.

CAUTION:

The battery can be run down easily, so connect booster cables to another vehicle or charged battery.

B2 RB26 DOHC EGI (ECCS) TWIN-TURBOCHARGER ENGINE

11. Engine Removal and Installation (Cont'd)

[Point 2] Accelerator wire adjustment

- Loosen lock nut to provide adequate slack for the accelerator wire, and pull outer case in the direction of the accelerator pedal until throttle drum starts to move (when there is no play in cable). Return lock nut 1.0 to 1.5 turns then tighten.

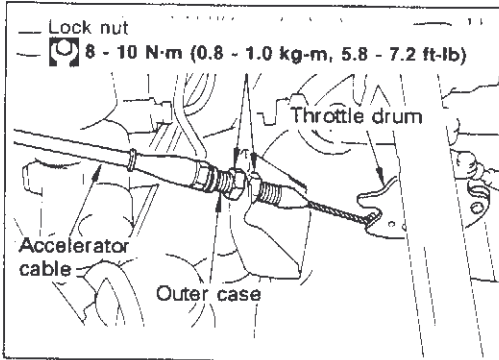

Tightening torque

8 - 10 N·m (0.8 - 1.0 kg-m, 5.8 - 7.2 ft-lb)

[Point 3] Engine main harness, ground line separation

- Disconnect connectors behind battery for harnesses of alternator, starter motor and transmission systems.

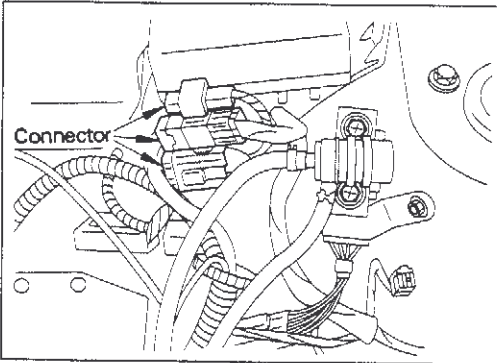

[Point 4] Air compressor, power steering oil pump movement

- Remove bolts securing each unit to brackets. Leave pipes connected and secure to side of body with string, being careful not to scratch body.

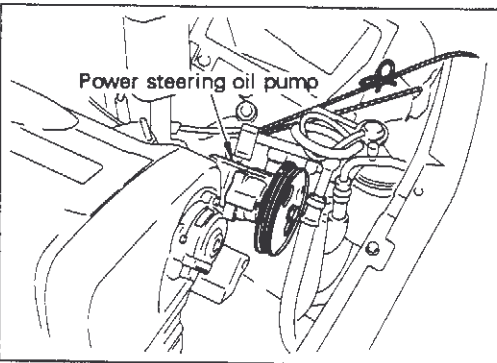

[Point 5] Power steering fluid tube bracket separation

- Remove bolts, and separate power steering fluid tube bracket, and move toward body side.

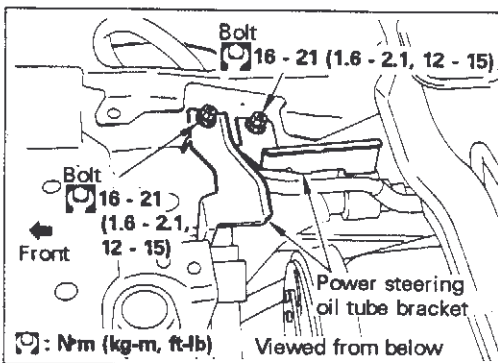

[Point 6] Front engine mounting nut removal

- Make sure engine slings are securely hooked by engine hoist chain and remove front engine mounting nuts.

Tightening torque

43 - 55 N·m (4.4 - 5.6 kg-m, 32 - 41 ft-lb)

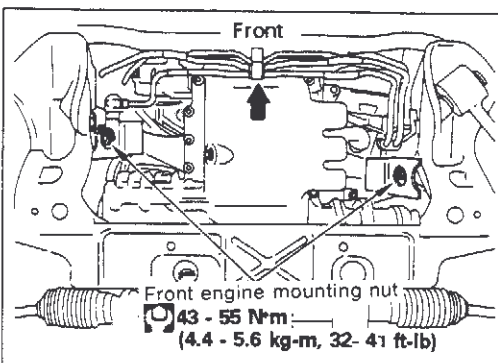

B2 RB26 DOHC EGI (ECCS) TWIN-TURBOCHARGER ENGINE

11. Engine Removal and Installation (Cont'd)

[Point 7] Right front engine mounting bracket removal

- Remove nut and remove right engine mounting bracket to move engine toward front of vehicle.

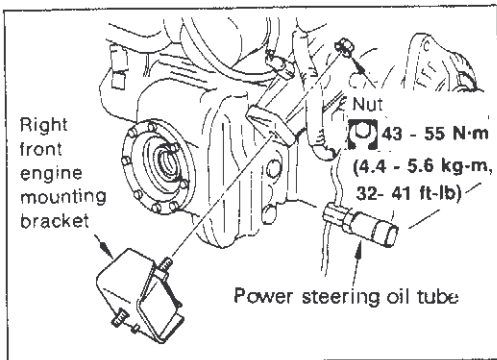

[Point 8] Engine ASSY removal and installation

- Operate hoist chain, and change engine angle gradually, being careful so it does not interfere with vehicle and remove engine.

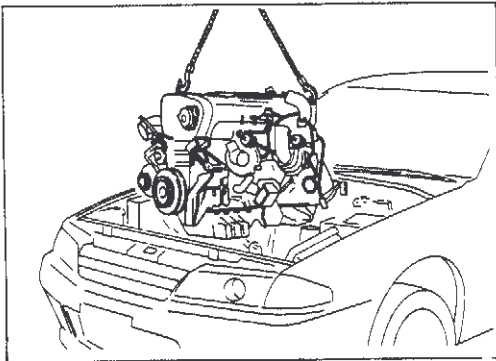

B2 RB26 DOHC EGI (ECCS) TWIN-TURBOCHARGER ENGINE

12. Oil Pan, Oil Pump and Oil Strainer Removal and Installation

Tools required

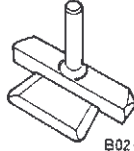
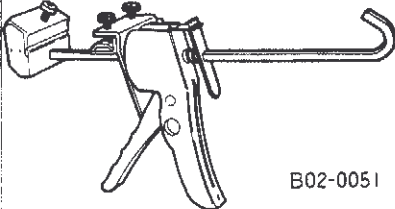
	Name	Application
Special tools	Seal cutter KV101 11100	 B02-0050 Oil pan removal
	Oil seal drift KV401 00900	
Tool	 B02-0051 Tube presser WS3993	Liquid gasket application

(1) OIL PAN, OIL PUMP AND OIL STRAINER REMOVAL AND INSTALLATION

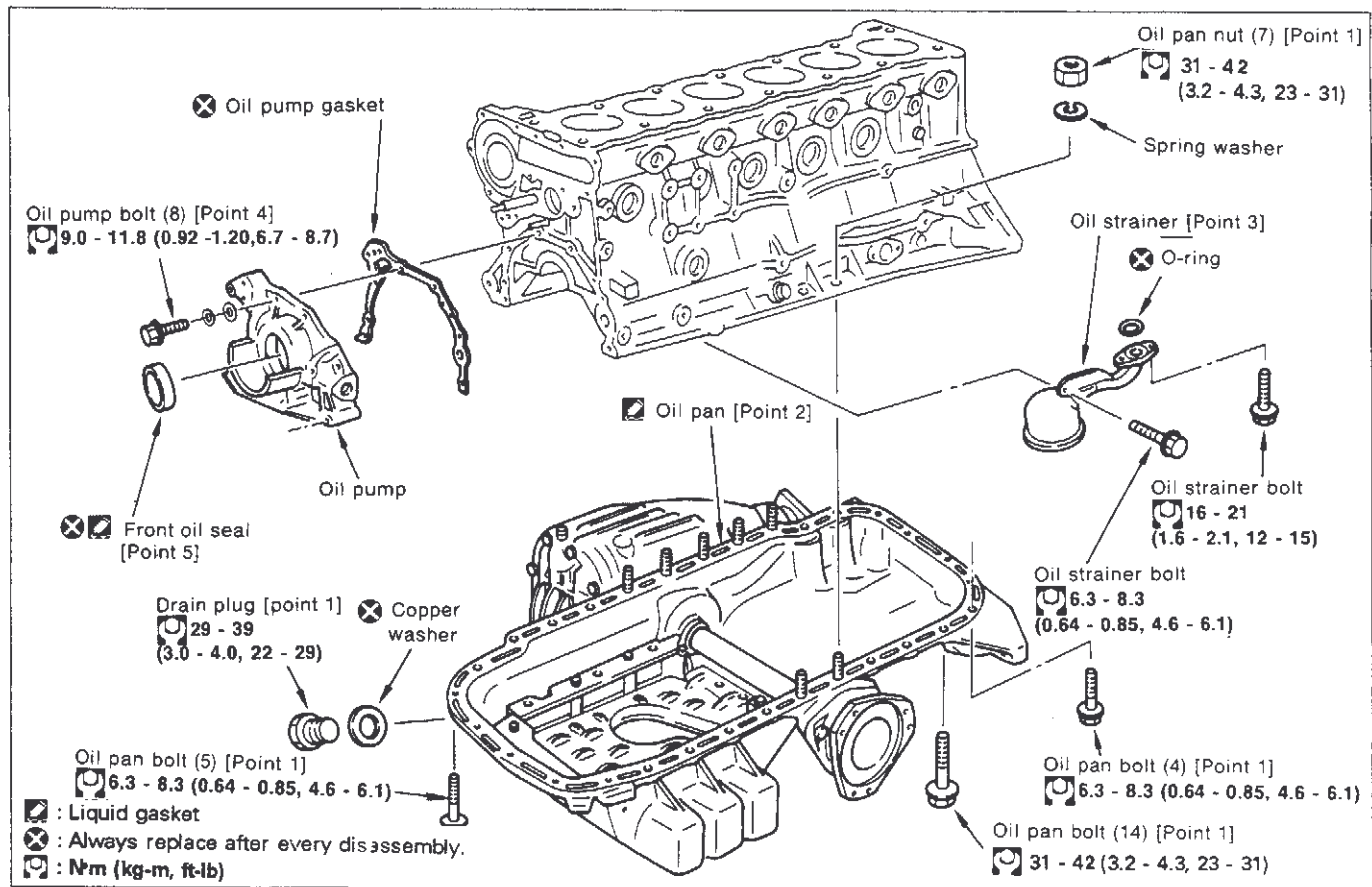

Additional work required:

- Engine ASSY removal and installation
- Engine oil draining and refilling

B2 RB26 DOHC EGI (ECCS) TWIN-TURBOCHARGER ENGINE

12. Oil Pan, Oil Pump and Oil Strainer Removal and Installation (Cont'd)

[Point 1] Oil pan bolt, nut removal and installation

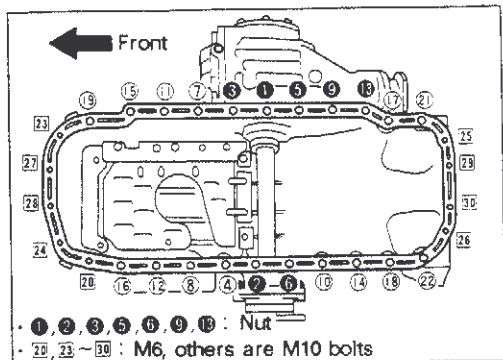

Removal

- Remove bolts and nuts in reverse order of installation shown in figure on left.

Installation

- Tighten nuts and bolts in numerical order shown in figure on left.

CAUTION:

Make sure there is no dirt, dust or debris on oil pan installation surface.

Installation position	Bolt size	Number of bolts	Tightening torque N·m (kg·m, ft·lb)
20, 23 - 30	M6	9	6.3 - 8.3 (0.64 - 0.85, 4.6 - 6.1)
4, 7, 8, 10 - 12, 14 - 19, 21, 22	M10	14	31 - 42 (3.2 - 4.3, 23 - 31)
1, 2, 3, 5, 6, 9, 13	M10 (nut)	7	31 - 42 (3.2 - 4.3, 23 - 31)

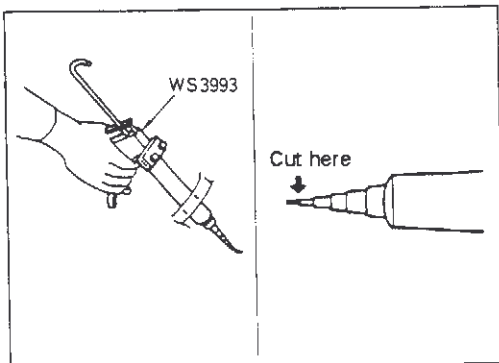
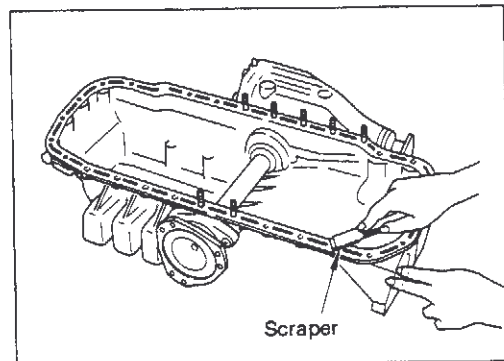
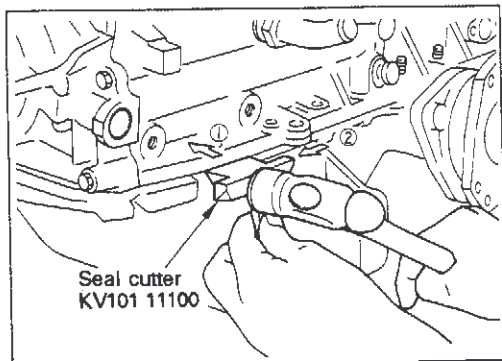

[Point 2] Oil pan removal and installation

Removal and cleaning

- Insert seal cutter between cylinder block and oil pan and remove oil pan by tapping seal cutter.

- Use a scraper to remove all traces of liquid gasket from mating surface.

CAUTION:

- Use a scraper to remove all liquid gasket and seal material attached to cylinder block and oil pan flange groove. Remove all gasket material and other debris that falls into the oil pan.
 - Be careful not to scratch oil pan.
- Clean all contact surfaces with white gasoline or equivalent.

Installation

- Cut off nozzle tip of liquid gasket (KP510 00510) at point shown in figure on left and insert in tube presser.

B2 RB26 DOHC EGI (ECCS) TWIN-TURBOCHARGER ENGINE

12. Oil Pan, Oil Pump and Oil Strainer Removal and Installation (Cont'd)

Installation

Apply liquid gasket to inner sealing surfaces as shown in figure. Installation should be performed within 5 minutes after coating.

- Apply a continuous bead of liquid gasket (KP510 00150) to mating surfaces of oil pan.

- Apply liquid gasket (KP510 00150) to areas 7 mm (0.28 in) inside from center of oil pan bolt holes.

CAUTION:

- (1) Be sure liquid gasket application is 4.0 mm (0.157 in) wide.
- (2) Wait at least 30 minutes before refilling engine oil and engine coolant.

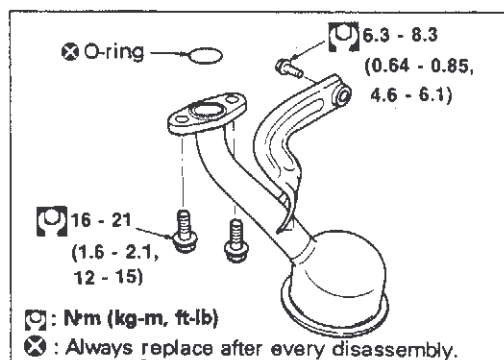
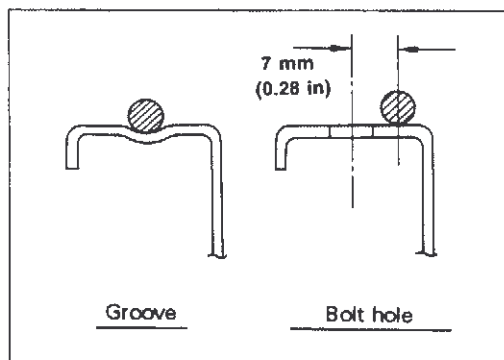
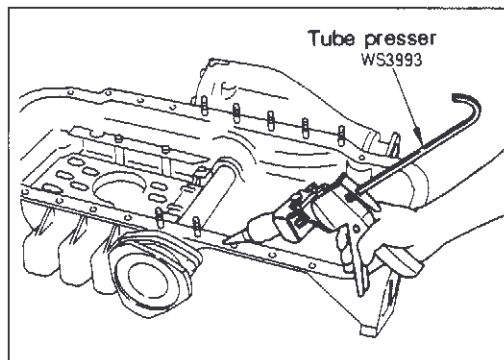

[Point 3] Oil strainer installation

- When installing oil strainer, make sure O-ring is inserted securely in groove and then install.

Tightening torque N·m (kg-m, ft-lb)	M8	16 - 21 (1.6 - 2.1, 12 - 15)
	M6	6.3 - 8.3 (0.64 - 0.85, 4.6 - 6.1)

[Point 4] Oil pump installation bolts

- There are 4 types of bolts so be careful not to mistake them when they are installed.

Installation position	Length below head mm (in)	Number of bolts	Tightening torque N·m (kg-m, ft-lb)
①	20 (0.79)	4	9.0 - 11.8 (0.92 - 1.2, 6.7 - 8.7)
②	35 (1.38)	2	9.0 - 11.8 (0.92 - 1.2, 6.7 - 8.7)
③	45 (1.77)	1	9.0 - 11.8 (0.92 - 1.2, 6.7 - 8.7)
④	55 (2.17)	1	9.0 - 11.8 (0.92 - 1.2, 6.7 - 8.7)

[Point 5] Front oil seal removal and installation

Removal

- Use a screwdriver to remove front oil seal from front cover.

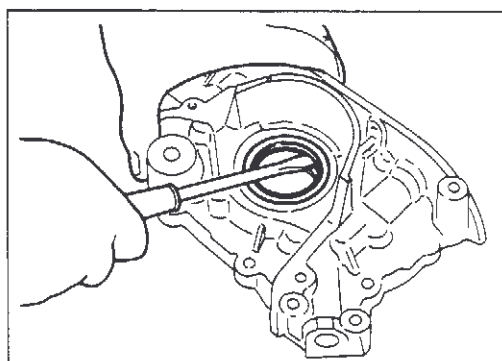

B2 RB26 DOHC EGI (ECCS) TWIN-TURBOCHARGER ENGINE

12. Oil Pan, Oil Pump and Oil Strainer Removal and Installation (Cont'd)

Installation

- Be careful not to scratch or damage oil seal retainer. Use oil seal drift and insert it at same level as front surface of oil pump housing.
- Apply engine oil or chassis grease to area around oil seal lip.

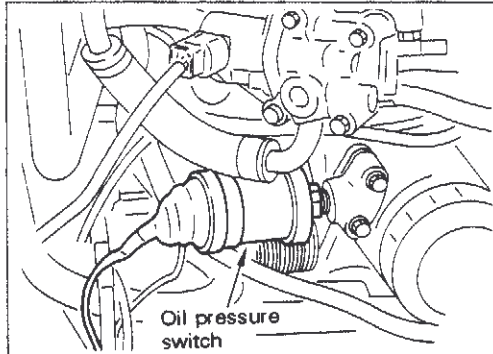
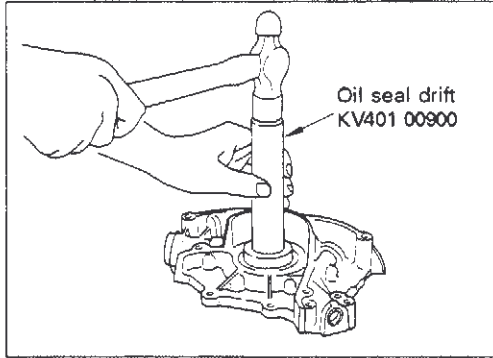

[Point 6] Oil leak and oil pressure check

- After installation, warm up engine and check for oil leaks and proper oil pressure.
- To perform oil pressure inspection, remove oil pressure switch and attach oil pressure gauge.

Engine speed (rpm)	Idling	2,000	6,000
Delivery pressure kPa (kg/cm ² , psi)	Approx. 147 (1.5, 21)	Approx. 294 (3, 43)	Approx. 451 (4.6, 65)

Oil temperature at 80°C (176°F)

(2) OIL PAN DISASSEMBLY AND ASSEMBLY

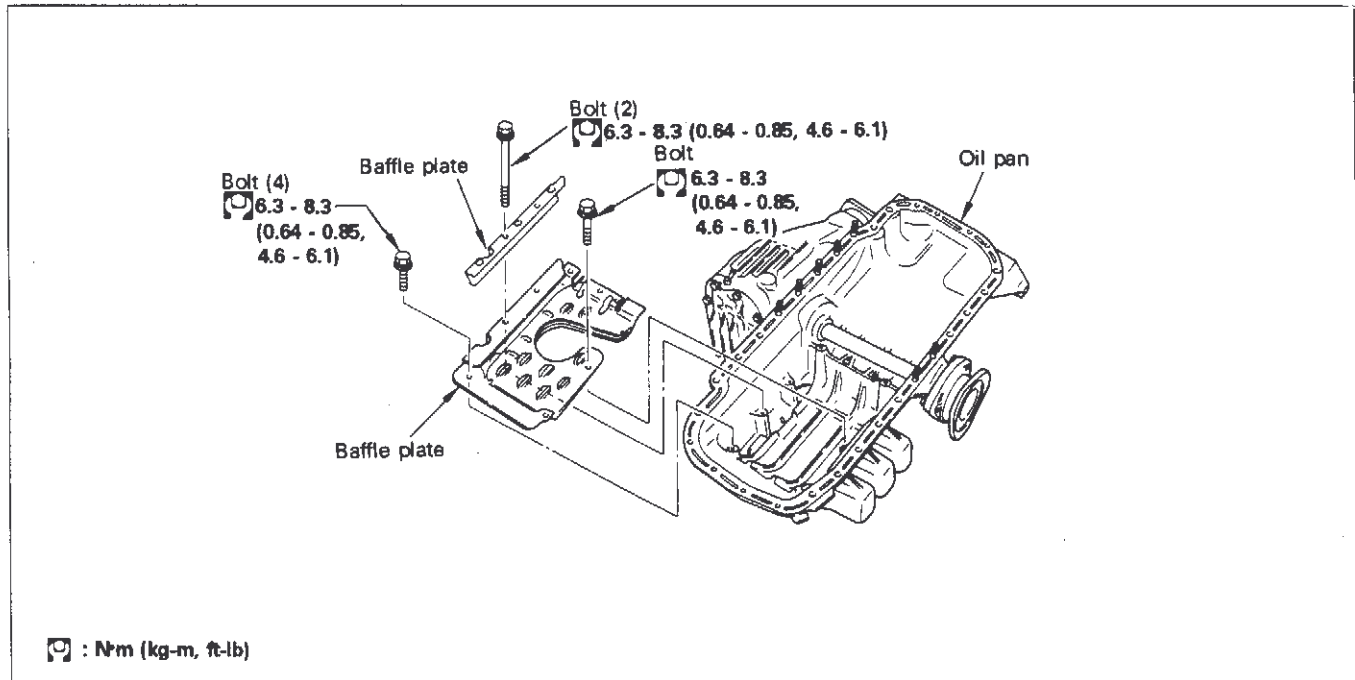

B2 RB26 DOHC EGI (ECCS) TWIN-TURBOCHARGER ENGINE

12. Oil Pan, Oil Pump and Oil Strainer Removal and Installation (Cont'd)

(3) OIL PUMP DISASSEMBLY AND ASSEMBLY

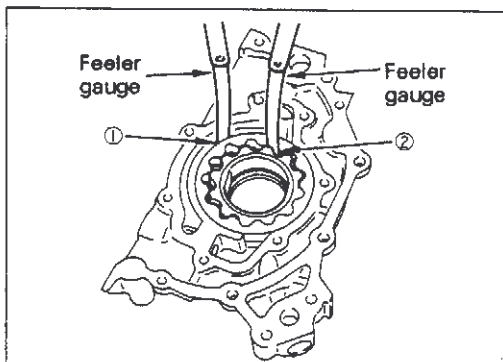
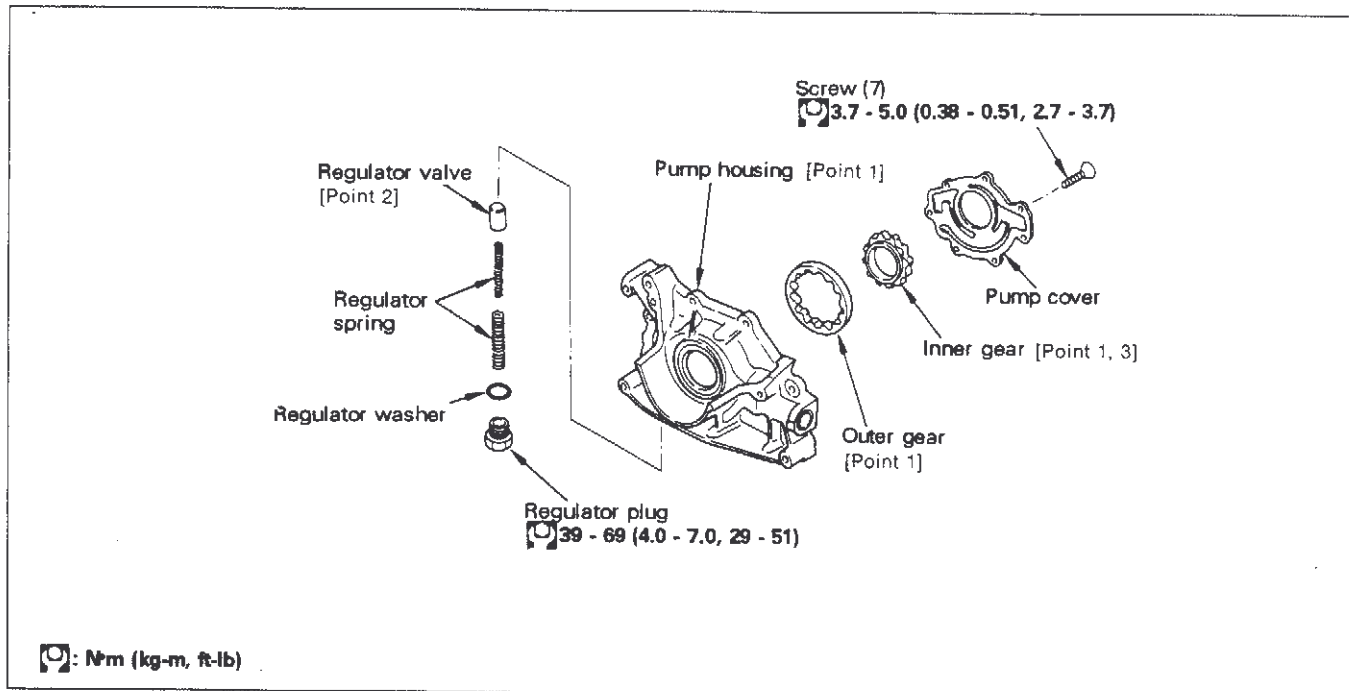

[Point 1] Oil pump inspection

- Check inner gear, outer gear and housing for scratches or wear.
- Use a feeler gauge and measure the following clearances:

Measurement position		Standard value	mm (in)
①	Outer gear and housing clearance	0.114 - 0.2	(0.0045 - 0.0079)
②	Outer gear and inner gear top clearance	0.180	(0.0071) max.
③	Inner gear and housing side clearance	0.05 - 0.07	(0.0020 - 0.0028)
④	Outer gear and housing side clearance	0.05 - 0.11	(0.0020 - 0.0043)
⑤	Inner gear and housing flange clearance	0.045 - 0.091	(0.0018 - 0.0036)

CAUTION:

Measurement position ⑤ is the figure obtained by subtracting the housing flange outside diameter from the inner gear inside diameter.

B2 RB26 DOHC EGI (ECCS) TWIN-TURBOCHARGER ENGINE

12. Oil Pan, Oil Pump and Oil Strainer Removal and Installation (Cont'd)

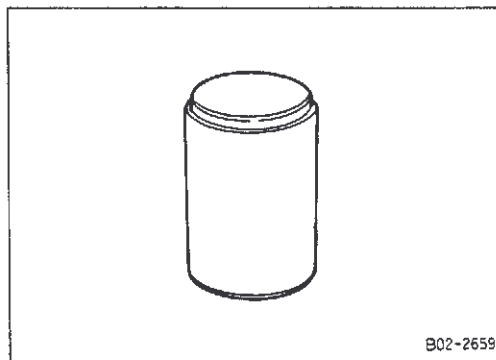
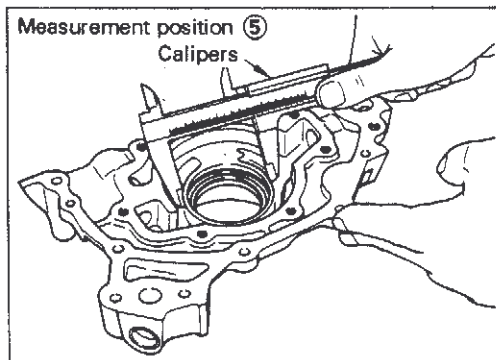
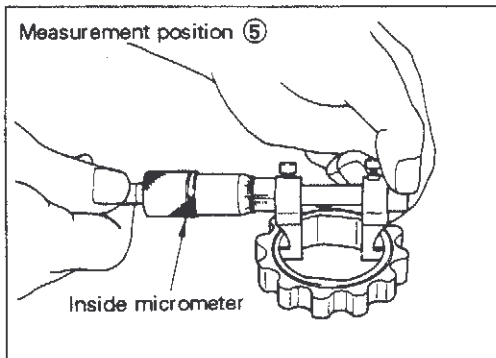
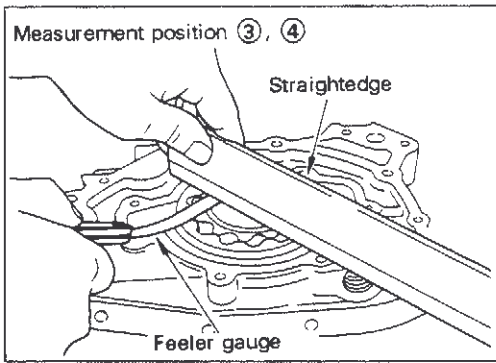

[Point 2] Regulator inspection

- Check oil pressure regulator valve sliding surface and spring for wear and damage.

Valve and valve hole clearance	0.04 - 0.097 mm (0.0016 - 0.0038 in)
--------------------------------	--------------------------------------

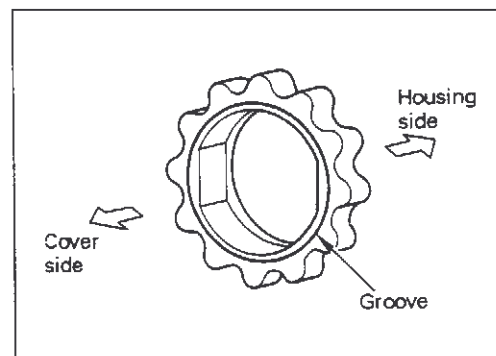

[Point 3] Inner gear installation

- Be careful because the inner gear has specific assembly direction.
- The side with the groove must face the cover side.

13. Engine Overhaul

This section describes the complete disassembly of the engine assembly removed from vehicle without transmission. It also explains the inspection, replacement of malfunctioning, damaged or worn parts, necessary adjustments and sequential assembly order to produce a standard engine condition.

13-1 OVERHAUL CAUTIONS

(1) Disassembly

- ① Use correct and suitable tools whenever possible, and do not try any unsafe or unreasonable procedures.
- ② Be careful with operations on mating surfaces and sliding surfaces to prevent loss of surface accuracy.
- ③ Make marks on disassembled parts for organized, thorough damage detection and precise assembly.
- ④ Loosen nuts and bolts in a diagonal direction from the outside, being careful to follow the numerical order when indicated.

(2) Inspection, repair and replacement

- ① Repair or replace after completing parts inspection following the inspection procedures. Perform the same inspection for the new parts and replace parts as necessary.

(3) Assembly

- ① Always use a torque wrench to tighten nuts and bolts to the specified torque.
- ② Tighten nuts and bolts from the center to the outside diagonal direction, gradually in two or three successive stages. Follow the numerical order when indicated.
- ③ Gaskets, packing, oil seals and O-rings should be replaced with new ones in principle.
- ④ Each part should be cleaned thoroughly and blown off with compressed air. In particular, check that oil and water passages are not clogged or obstructed.
- ⑤ Be careful not to scratch or damage sliding or mating surfaces. Clean off all dust, debris or foreign matter. Lubricate all sliding surfaces with an adequate coating of oil.



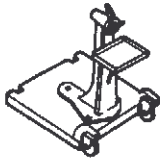
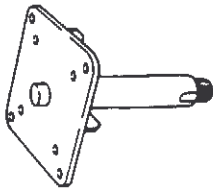
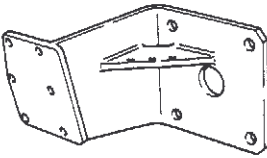

13-2 CYLINDER BLOCK ASSY ASSEMBLY AND DISASSEMBLY

Tools required

	Name		Application
Special tools	Engine stand ASSY ST0501 S000		Engine main unit overhaul
	Engine attachment KV101 06500		
	Engine sub-attachment KV101 14500		

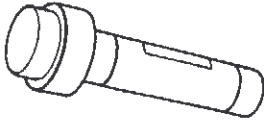
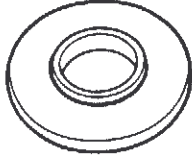
B2 RB26 DOHC EGI (ECCS) TWIN-TURBOCHARGER ENGINE

13. Engine Overhaul (Cont'd)

	Name		Application
Special tools	Rear axle bearing drift KV401 00900		Rear oil seal installation
	Rear oil seal drift ST3002 2000		
	Pilot bearing puller ST1661 0001		Pilot bushing removal
Tools	Piston ring compressor		Piston ASSY installation
	Piston ring expander		Piston ring removal and installation
Measurement tools	Dial gauge		Crankshaft, etc. inspection
	Magnetic stand		Crankshaft, etc. inspection
	Inside micrometer		Connecting rod, etc. inspection
	Plastigage		Oil clearance inspection
	Micrometer		Piston, etc. inspection
	Connecting rod aligner		Connecting rod inspection
	Bore gauge		Cylinder block, etc. inspection
	V-block		Crankshaft, etc. inspection
Service settings	Engine slinger	 Front	Engine removal and installation
		 Rear	

B2 RB26 DOHC EGI (ECCS) TWIN-TURBOCHARGER ENGINE

13. Engine Overhaul (Cont'd)

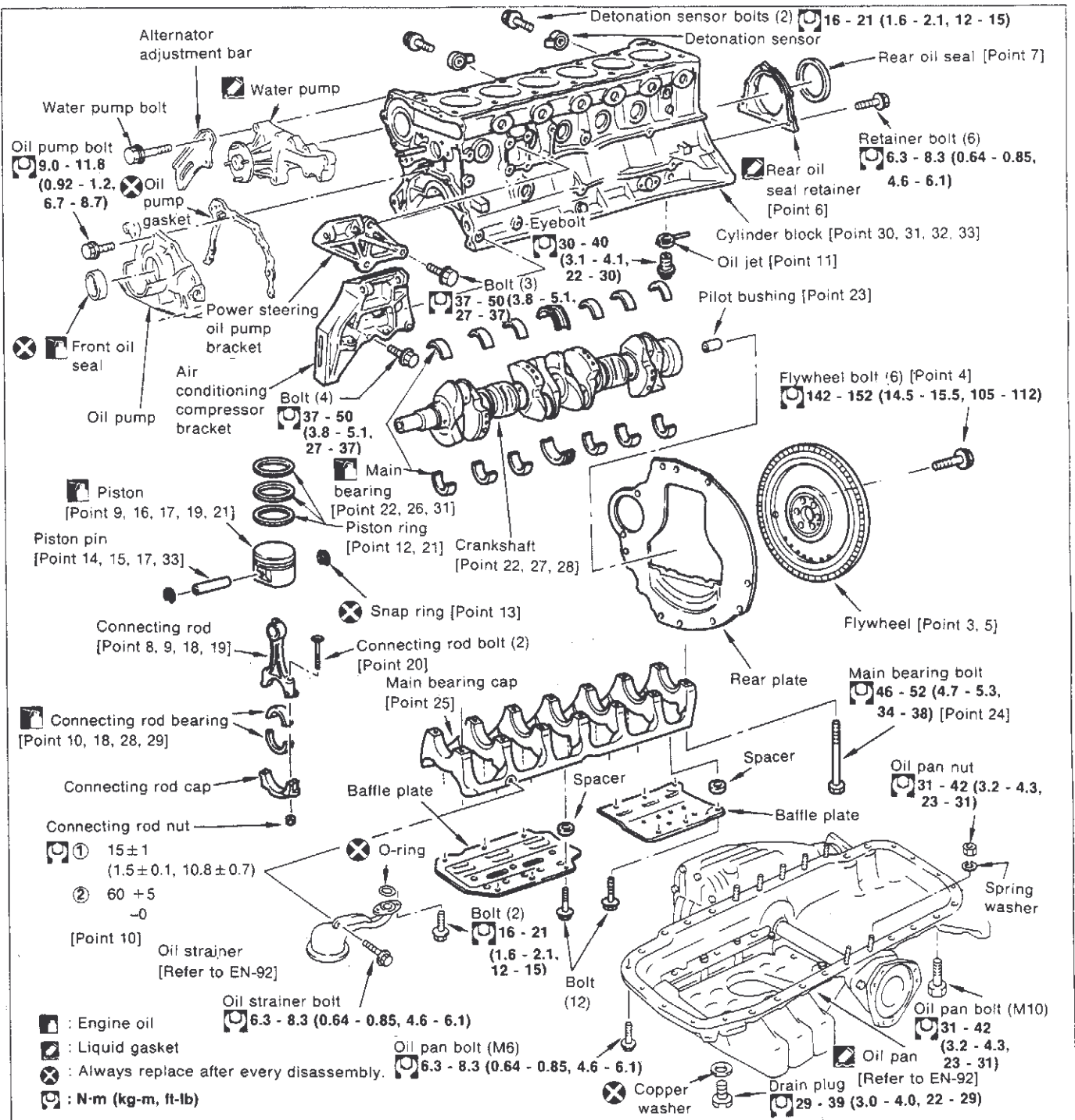

Additional work required:

- Drain and refill: cooling water [Point 1]
 - Remove and install:
 - Engine
 - Collector
 - Throttle chamber
 - Intake manifold
 - Turbocharger, exhaust manifold
 - Timing belt
 - Cylinder head ASSY
 - Alternator
 - Starter motor
 - Clutch cover, clutch disc
 - Oil pan, oil strainer
- Water pump
 Oil pump
 Oil cooler, oil strainer
 All harnesses and connectors

B2 RB26 DOHC EGI (ECCS) TWIN-TURBOCHARGER ENGINE

13. Engine Overhaul (Cont'd)

Reference: Engine selection assembly

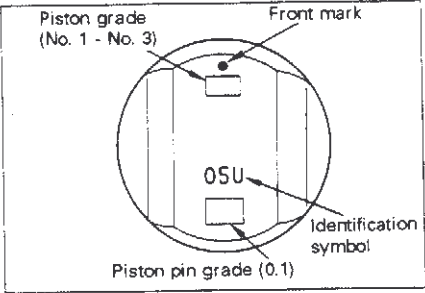
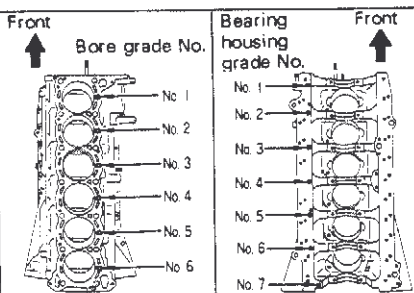
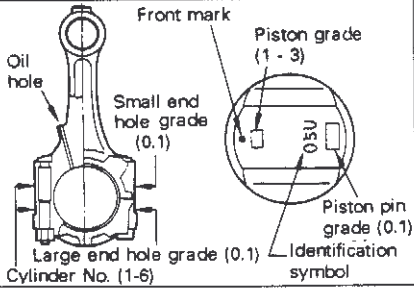
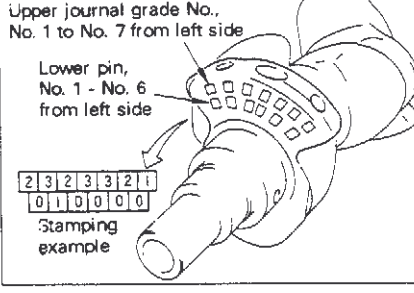
Part	Grade Indication	Selection Combination																																																																																																		
Piston		<p>① Piston selection Unit: mm (in)</p> <table border="1"> <thead> <tr> <th>(Stamp)</th> <th>1</th> <th>2</th> <th>3</th> </tr> </thead> <tbody> <tr> <td>Grade No.</td> <td></td> <td></td> <td></td> </tr> <tr> <td>Cylinder block bore diameter</td> <td>86.010 (3.3852) Max. Greater than 86.000 (3.3858)</td> <td>86.020 (3.3866) Max. Greater than 86.010 (3.3862)</td> <td>86.030 (3.3870) Max. Greater than 86.020 (3.3866)</td> </tr> <tr> <td>Piston diameter</td> <td>85.965 (3.3844) Max. Greater than 85.955 (3.3840)</td> <td>85.975 (3.3848) Max. Greater than 85.965 (3.3844)</td> <td>85.985 (3.3852) Max. Greater than 85.975 (3.3848)</td> </tr> <tr> <td>Piston clearance</td> <td colspan="3">0.035 - 0.055 (0.0014 - 0.0022)</td> </tr> </tbody> </table> <p>Service setting part Piston and piston pin STD 1, STD 2, STD 3, 0.50S, 1.00S</p>	(Stamp)	1	2	3	Grade No.				Cylinder block bore diameter	86.010 (3.3852) Max. Greater than 86.000 (3.3858)	86.020 (3.3866) Max. Greater than 86.010 (3.3862)	86.030 (3.3870) Max. Greater than 86.020 (3.3866)	Piston diameter	85.965 (3.3844) Max. Greater than 85.955 (3.3840)	85.975 (3.3848) Max. Greater than 85.965 (3.3844)	85.985 (3.3852) Max. Greater than 85.975 (3.3848)	Piston clearance	0.035 - 0.055 (0.0014 - 0.0022)																																																																																
	(Stamp)	1	2	3																																																																																																
	Grade No.																																																																																																			
	Cylinder block bore diameter	86.010 (3.3852) Max. Greater than 86.000 (3.3858)	86.020 (3.3866) Max. Greater than 86.010 (3.3862)	86.030 (3.3870) Max. Greater than 86.020 (3.3866)																																																																																																
Piston diameter	85.965 (3.3844) Max. Greater than 85.955 (3.3840)	85.975 (3.3848) Max. Greater than 85.965 (3.3844)	85.985 (3.3852) Max. Greater than 85.975 (3.3848)																																																																																																	
Piston clearance	0.035 - 0.055 (0.0014 - 0.0022)																																																																																																			
Main bearing		<p>② Main bearing selection Unit: mm (in)</p> <table border="1"> <thead> <tr> <th rowspan="2">Cylinder block bearing housing inner diameter</th> <th rowspan="2">Grade No stamp</th> <th>58.651 (2.3091) Max. Greater than 58.645 (2.3089)</th> <th>58.657 (2.3093) Max. Greater than 58.651 (2.3091)</th> <th>58.663 (2.3096) Max. Greater than 58.657 (2.3093)</th> <th>58.670 (2.3098) Max. Greater than 58.663 (2.3096)</th> </tr> <tr> <th>0</th> <th>1</th> <th>2</th> <th>3</th> </tr> </thead> <tbody> <tr> <td rowspan="4">Crankshaft journal diameter</td> <td rowspan="4">0</td> <td>Bearing grade No.</td> <td>STD 0</td> <td>STD 1</td> <td>STD 2</td> <td>STD 3</td> </tr> <tr> <td>Bearing thickness</td> <td>1.818 - 1.821 (0.0716 - 0.0717)</td> <td>1.821 - 1.824 (0.0717 - 0.0718)</td> <td>1.824 - 1.827 (0.0718 - 0.0719)</td> <td>1.827 - 1.830 (0.0719 - 0.0720)</td> </tr> <tr> <td>Oil clearance</td> <td>0.028/0.046 (0.0011/0.0018)</td> <td>0.028/0.046 (0.0011/0.0018)</td> <td>0.028/0.046 (0.0011/0.0018)</td> <td>0.028/0.047 (0.0011/0.0019)</td> </tr> <tr> <td>Identification color</td> <td>Black</td> <td>Brown</td> <td>None</td> <td>Yellow</td> </tr> <tr> <td rowspan="4">54.975 (2.1644) Max. Greater than 54.969 (2.1641)</td> <td rowspan="4">1</td> <td>Bearing grade No.</td> <td>STD 1</td> <td>STD 2</td> <td>STD 3</td> <td>STD 4</td> </tr> <tr> <td>Bearing thickness</td> <td>1.821 - 1.824 (0.0717 - 0.0718)</td> <td>1.824 - 1.827 (0.0718 - 0.0719)</td> <td>1.827 - 1.830 (0.0719 - 0.0720)</td> <td>1.830 - 1.833 (0.0720 - 0.0722)</td> </tr> <tr> <td>Oil clearance</td> <td>0.028/0.046 (0.0011/0.0018)</td> <td>0.028/0.046 (0.0011/0.0018)</td> <td>0.028/0.046 (0.0011/0.0018)</td> <td>0.028/0.047 (0.0011/0.0019)</td> </tr> <tr> <td>Identification color</td> <td>Brown</td> <td>None</td> <td>Yellow</td> <td>Blue</td> </tr> <tr> <td rowspan="4">54.963 (2.1639) Max. Greater than 54.957 (2.1637)</td> <td rowspan="4">2</td> <td>Bearing grade No.</td> <td>STD 2</td> <td>STD 3</td> <td>STD 4</td> <td>STD 5</td> </tr> <tr> <td>Bearing thickness</td> <td>1.824 - 1.827 (0.0718 - 0.0719)</td> <td>1.827 - 1.830 (0.0719 - 0.0720)</td> <td>1.830 - 1.833 (0.0720 - 0.0722)</td> <td>1.833 - 1.836 (0.0722 - 0.0723)</td> </tr> <tr> <td>Oil clearance</td> <td>0.028/0.046 (0.0011/0.0018)</td> <td>0.028/0.046 (0.0011/0.0018)</td> <td>0.028/0.046 (0.0011/0.0018)</td> <td>0.028/0.047 (0.0011/0.0019)</td> </tr> <tr> <td>Identification color</td> <td>None</td> <td>Yellow</td> <td>Blue</td> <td>Green</td> </tr> <tr> <td rowspan="4">54.957 (2.1637) Max. Greater than 54.951 (2.1634)</td> <td rowspan="4">3</td> <td>Bearing grade No.</td> <td>STD 3</td> <td>STD 4</td> <td>STD 5</td> <td>STD 6</td> </tr> <tr> <td>Bearing thickness</td> <td>1.827 - 1.830 (0.0719 - 0.0720)</td> <td>1.830 - 1.833 (0.0720 - 0.0722)</td> <td>1.833 - 1.836 (0.0722 - 0.0723)</td> <td>1.836 - 1.839 (0.0723 - 0.0724)</td> </tr> <tr> <td>Oil clearance</td> <td>0.028/0.046 (0.0011/0.0018)</td> <td>0.028/0.046 (0.0011/0.0018)</td> <td>0.028/0.046 (0.0011/0.0018)</td> <td>0.028/0.047 (0.0011/0.0019)</td> </tr> <tr> <td>Identification color</td> <td>Yellow</td> <td>Blue</td> <td>Green</td> <td>Pink</td> </tr> </tbody> </table> <p>Service setting parts. STD 0 - 6. US 0.25 mm (0.0098 in)</p>	Cylinder block bearing housing inner diameter	Grade No stamp	58.651 (2.3091) Max. Greater than 58.645 (2.3089)	58.657 (2.3093) Max. Greater than 58.651 (2.3091)	58.663 (2.3096) Max. Greater than 58.657 (2.3093)	58.670 (2.3098) Max. Greater than 58.663 (2.3096)	0	1	2	3	Crankshaft journal diameter	0	Bearing grade No.	STD 0	STD 1	STD 2	STD 3	Bearing thickness	1.818 - 1.821 (0.0716 - 0.0717)	1.821 - 1.824 (0.0717 - 0.0718)	1.824 - 1.827 (0.0718 - 0.0719)	1.827 - 1.830 (0.0719 - 0.0720)	Oil clearance	0.028/0.046 (0.0011/0.0018)	0.028/0.046 (0.0011/0.0018)	0.028/0.046 (0.0011/0.0018)	0.028/0.047 (0.0011/0.0019)	Identification color	Black	Brown	None	Yellow	54.975 (2.1644) Max. Greater than 54.969 (2.1641)	1	Bearing grade No.	STD 1	STD 2	STD 3	STD 4	Bearing thickness	1.821 - 1.824 (0.0717 - 0.0718)	1.824 - 1.827 (0.0718 - 0.0719)	1.827 - 1.830 (0.0719 - 0.0720)	1.830 - 1.833 (0.0720 - 0.0722)	Oil clearance	0.028/0.046 (0.0011/0.0018)	0.028/0.046 (0.0011/0.0018)	0.028/0.046 (0.0011/0.0018)	0.028/0.047 (0.0011/0.0019)	Identification color	Brown	None	Yellow	Blue	54.963 (2.1639) Max. Greater than 54.957 (2.1637)	2	Bearing grade No.	STD 2	STD 3	STD 4	STD 5	Bearing thickness	1.824 - 1.827 (0.0718 - 0.0719)	1.827 - 1.830 (0.0719 - 0.0720)	1.830 - 1.833 (0.0720 - 0.0722)	1.833 - 1.836 (0.0722 - 0.0723)	Oil clearance	0.028/0.046 (0.0011/0.0018)	0.028/0.046 (0.0011/0.0018)	0.028/0.046 (0.0011/0.0018)	0.028/0.047 (0.0011/0.0019)	Identification color	None	Yellow	Blue	Green	54.957 (2.1637) Max. Greater than 54.951 (2.1634)	3	Bearing grade No.	STD 3	STD 4	STD 5	STD 6	Bearing thickness	1.827 - 1.830 (0.0719 - 0.0720)	1.830 - 1.833 (0.0720 - 0.0722)	1.833 - 1.836 (0.0722 - 0.0723)	1.836 - 1.839 (0.0723 - 0.0724)	Oil clearance	0.028/0.046 (0.0011/0.0018)	0.028/0.046 (0.0011/0.0018)	0.028/0.046 (0.0011/0.0018)	0.028/0.047 (0.0011/0.0019)	Identification color	Yellow	Blue	Green	Pink
	Cylinder block bearing housing inner diameter	Grade No stamp			58.651 (2.3091) Max. Greater than 58.645 (2.3089)	58.657 (2.3093) Max. Greater than 58.651 (2.3091)	58.663 (2.3096) Max. Greater than 58.657 (2.3093)	58.670 (2.3098) Max. Greater than 58.663 (2.3096)																																																																																												
			0	1	2	3																																																																																														
	Crankshaft journal diameter	0	Bearing grade No.	STD 0	STD 1	STD 2	STD 3																																																																																													
Bearing thickness			1.818 - 1.821 (0.0716 - 0.0717)	1.821 - 1.824 (0.0717 - 0.0718)	1.824 - 1.827 (0.0718 - 0.0719)	1.827 - 1.830 (0.0719 - 0.0720)																																																																																														
Oil clearance			0.028/0.046 (0.0011/0.0018)	0.028/0.046 (0.0011/0.0018)	0.028/0.046 (0.0011/0.0018)	0.028/0.047 (0.0011/0.0019)																																																																																														
Identification color			Black	Brown	None	Yellow																																																																																														
54.975 (2.1644) Max. Greater than 54.969 (2.1641)	1	Bearing grade No.	STD 1	STD 2	STD 3	STD 4																																																																																														
		Bearing thickness	1.821 - 1.824 (0.0717 - 0.0718)	1.824 - 1.827 (0.0718 - 0.0719)	1.827 - 1.830 (0.0719 - 0.0720)	1.830 - 1.833 (0.0720 - 0.0722)																																																																																														
		Oil clearance	0.028/0.046 (0.0011/0.0018)	0.028/0.046 (0.0011/0.0018)	0.028/0.046 (0.0011/0.0018)	0.028/0.047 (0.0011/0.0019)																																																																																														
		Identification color	Brown	None	Yellow	Blue																																																																																														
54.963 (2.1639) Max. Greater than 54.957 (2.1637)	2	Bearing grade No.	STD 2	STD 3	STD 4	STD 5																																																																																														
		Bearing thickness	1.824 - 1.827 (0.0718 - 0.0719)	1.827 - 1.830 (0.0719 - 0.0720)	1.830 - 1.833 (0.0720 - 0.0722)	1.833 - 1.836 (0.0722 - 0.0723)																																																																																														
		Oil clearance	0.028/0.046 (0.0011/0.0018)	0.028/0.046 (0.0011/0.0018)	0.028/0.046 (0.0011/0.0018)	0.028/0.047 (0.0011/0.0019)																																																																																														
		Identification color	None	Yellow	Blue	Green																																																																																														
54.957 (2.1637) Max. Greater than 54.951 (2.1634)	3	Bearing grade No.	STD 3	STD 4	STD 5	STD 6																																																																																														
		Bearing thickness	1.827 - 1.830 (0.0719 - 0.0720)	1.830 - 1.833 (0.0720 - 0.0722)	1.833 - 1.836 (0.0722 - 0.0723)	1.836 - 1.839 (0.0723 - 0.0724)																																																																																														
		Oil clearance	0.028/0.046 (0.0011/0.0018)	0.028/0.046 (0.0011/0.0018)	0.028/0.046 (0.0011/0.0018)	0.028/0.047 (0.0011/0.0019)																																																																																														
		Identification color	Yellow	Blue	Green	Pink																																																																																														
Piston pin		<p>③ Piston pin selection Unit: mm (in)</p> <table border="1"> <thead> <tr> <th>(Stamp)</th> <th>1</th> <th>2</th> </tr> </thead> <tbody> <tr> <td>Grade No.</td> <td></td> <td></td> </tr> <tr> <td>Piston pin hole diameter (in)</td> <td>21.006 - 21.000 (0.8270 - 0.8268)</td> <td>21.012 - 21.006 (0.8272 - 0.8270)</td> </tr> <tr> <td>Piston pin external diameter (in)</td> <td>20.995 - 20.989 (0.8266 - 0.8263)</td> <td>21.001 - 20.995 (0.8268 - 0.8266)</td> </tr> <tr> <td>Piston pin clearance (in)</td> <td colspan="2">0.005 - 0.017 (0.0002 - 0.0007)</td> </tr> </tbody> </table> <p>Service setting Piston and piston pin STD 1, STD 2, STD 3, 0.50S, 1.00S</p>	(Stamp)	1	2	Grade No.			Piston pin hole diameter (in)	21.006 - 21.000 (0.8270 - 0.8268)	21.012 - 21.006 (0.8272 - 0.8270)	Piston pin external diameter (in)	20.995 - 20.989 (0.8266 - 0.8263)	21.001 - 20.995 (0.8268 - 0.8266)	Piston pin clearance (in)	0.005 - 0.017 (0.0002 - 0.0007)																																																																																				
	(Stamp)	1	2																																																																																																	
Grade No.																																																																																																				
Piston pin hole diameter (in)	21.006 - 21.000 (0.8270 - 0.8268)	21.012 - 21.006 (0.8272 - 0.8270)																																																																																																		
Piston pin external diameter (in)	20.995 - 20.989 (0.8266 - 0.8263)	21.001 - 20.995 (0.8268 - 0.8266)																																																																																																		
Piston pin clearance (in)	0.005 - 0.017 (0.0002 - 0.0007)																																																																																																			
Connecting rod bearing		<p>④ Connecting rod bearing selection Unit: mm (in)</p> <table border="1"> <thead> <tr> <th rowspan="2">Crank pin diameter</th> <th rowspan="2">Grade No. stamp</th> <th>Less than 51.007 (2.0081) 51.000 (2.0079) Min.</th> <th>51.013 (2.0084) Max. 51.007 (2.0081) Max.</th> </tr> <tr> <th>0</th> <th>1</th> </tr> </thead> <tbody> <tr> <td rowspan="3">47.974 (1.8887) Max. Greater than 47.968 (1.8885)</td> <td rowspan="3">0</td> <td>Bearing grade No.</td> <td>STD 0</td> </tr> <tr> <td>Bearing thickness</td> <td>1.500 - 1.503 (0.0591 - 0.0592)</td> </tr> <tr> <td>Oil clearance</td> <td>0.020/0.039 (0.0008/0.0015)</td> </tr> <tr> <td rowspan="3">47.968 (1.8885) Max. Greater than 47.961 (1.8882)</td> <td rowspan="3">1</td> <td>Bearing grade No.</td> <td>STD 1</td> </tr> <tr> <td>Bearing thickness</td> <td>1.503 - 1.506 (0.0592 - 0.0593)</td> </tr> <tr> <td>Oil clearance</td> <td>0.020/0.040 (0.0008/0.0016)</td> </tr> </tbody> </table> <p>Service setting parts US 0.08 mm (0.0031 in), US 0.12 mm (0.0047 in), US 0.25 mm (0.0098 in)</p>	Crank pin diameter	Grade No. stamp	Less than 51.007 (2.0081) 51.000 (2.0079) Min.	51.013 (2.0084) Max. 51.007 (2.0081) Max.	0	1	47.974 (1.8887) Max. Greater than 47.968 (1.8885)	0	Bearing grade No.	STD 0	Bearing thickness	1.500 - 1.503 (0.0591 - 0.0592)	Oil clearance	0.020/0.039 (0.0008/0.0015)	47.968 (1.8885) Max. Greater than 47.961 (1.8882)	1	Bearing grade No.	STD 1	Bearing thickness	1.503 - 1.506 (0.0592 - 0.0593)	Oil clearance	0.020/0.040 (0.0008/0.0016)																																																																												
Crank pin diameter	Grade No. stamp	Less than 51.007 (2.0081) 51.000 (2.0079) Min.			51.013 (2.0084) Max. 51.007 (2.0081) Max.																																																																																															
		0	1																																																																																																	
47.974 (1.8887) Max. Greater than 47.968 (1.8885)	0	Bearing grade No.	STD 0																																																																																																	
		Bearing thickness	1.500 - 1.503 (0.0591 - 0.0592)																																																																																																	
		Oil clearance	0.020/0.039 (0.0008/0.0015)																																																																																																	
47.968 (1.8885) Max. Greater than 47.961 (1.8882)	1	Bearing grade No.	STD 1																																																																																																	
		Bearing thickness	1.503 - 1.506 (0.0592 - 0.0593)																																																																																																	
		Oil clearance	0.020/0.040 (0.0008/0.0016)																																																																																																	

B2 RB26 DOHC EGI (ECCS) TWIN-TURBOCHARGER ENGINE

13. Engine Overhaul (Cont'd)

[Point 1] Cooling water, drain and refill

Draining

- Drain the water in the cylinder block completely from the drain plug.

Refilling

- Refer to Cooling Water Filling Method (B6) for details.

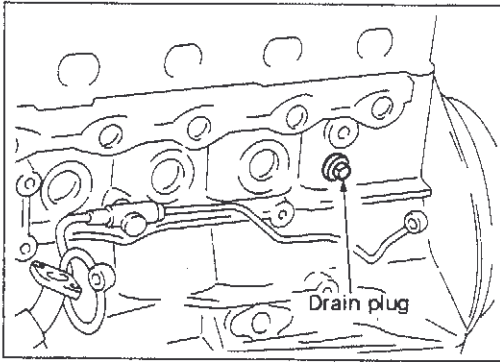

[Point 2] Engine stand installation and removal

- The engine sub-attachment is attached by 6 bolts to engine mounting bracket on right side of engine.

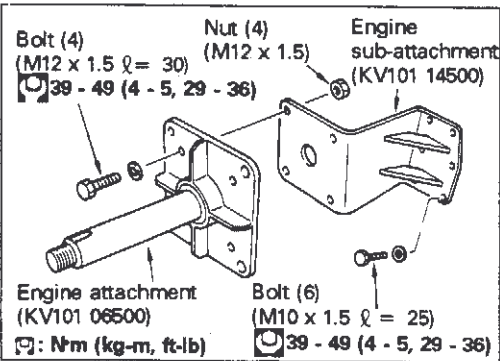
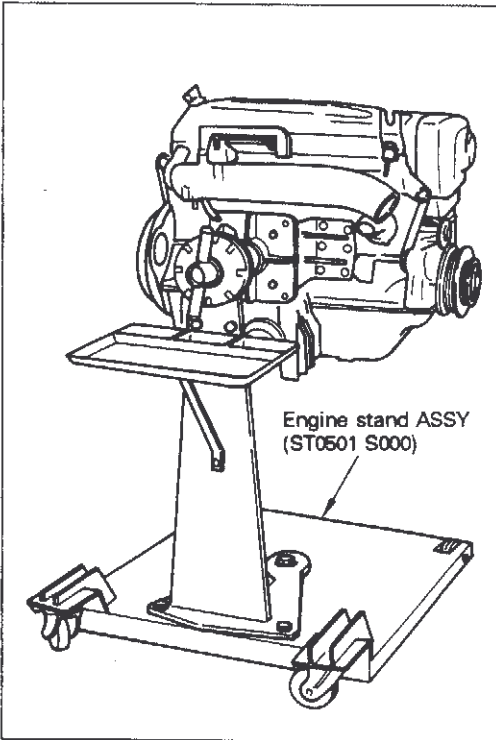

[Point 3] Flywheel runout

- Set dial gauge to flywheel where it contacts clutch.
- Turn the flywheel and measure the runout.

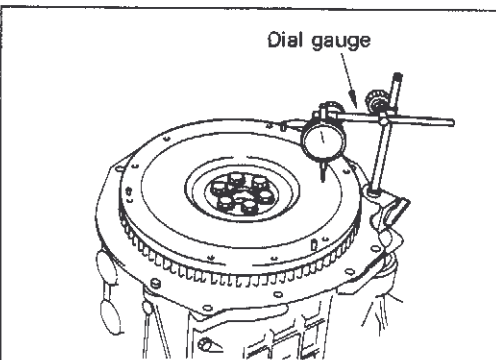

Runout (total indicator reading)	0.10 mm (0.0039 in)
----------------------------------	---------------------

13. Engine Overhaul (Cont'd)

[Point 4] Flywheel removal and installation

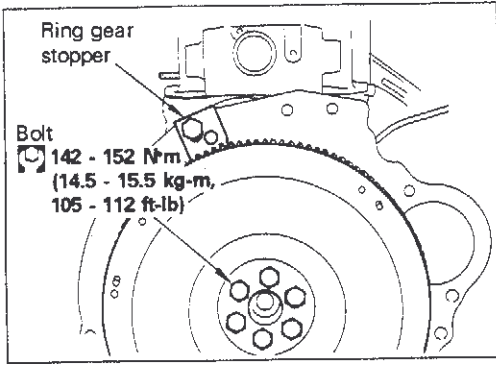

Removal

- Use ring gear stopper to secure flywheel and remove.

Installation

- Before installing bolts, coat the thread and flange of bolt with engine oil.
- After tightening the flywheel installation bolts halfway, use the ring gear stopper to secure flywheel and tighten bolts.

Flywheel bolt tightening torque	142 - 152 N·m (14.5 - 15.5 kg-m, 105 - 112 ft-lb)
---------------------------------	--

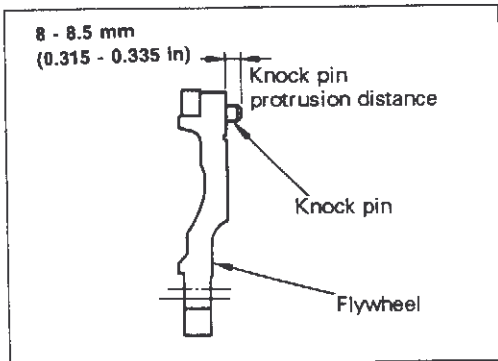

[Point 5] Flywheel knock pin insertion

- Insert the flywheel knock pin so pin protrudes 8 to 8.5 mm (0.315 to 0.335 in).

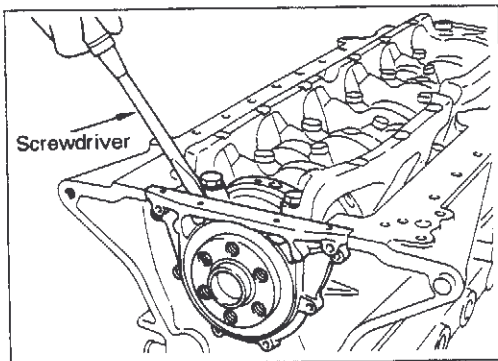

[Point 6] Rear oil seal retainer removal and installation

Removal

- Insert a screwdriver in the gap between main bearing cap and rear oil seal retainer to remove seal.

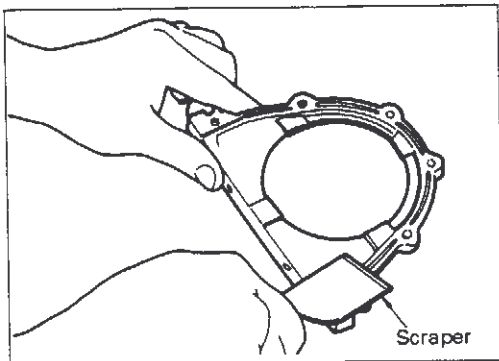

Cleaning

- Use a scraper to remove liquid gasket.

CAUTION:

Also remove liquid gasket in grooves.

- Clean the cylinder block side in the same way.
- Clean mating surface with white gasoline or equivalent.

13. Engine Overhaul (Cont'd)

Installation

- Apply liquid gasket to mating surface and install unit within 5 minutes after coating.
- Cut nozzle end of liquid gasket (KP510 00150) tube as shown in figure and use tube presser for application.

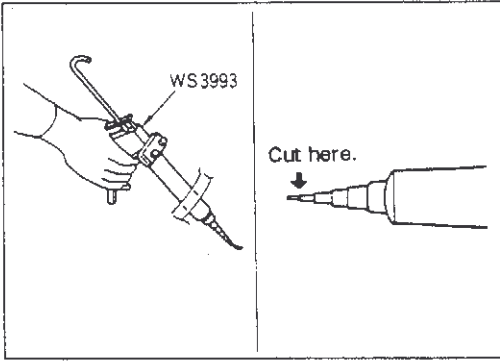

Apply a continuous bead of liquid gasket to mating surfaces 2.0 to 3.0 mm (0.079 to 0.118 in) wide.

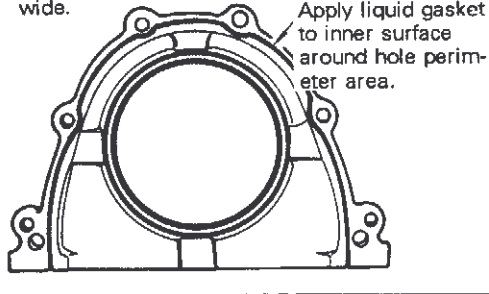

- Apply liquid gasket continuously to rear oil seal retainer as shown in the figure on left.

CAUTION:

- (1) Be sure liquid gasket is 2.0 to 3.0 mm (0.079 to 0.118 in) wide.
- (2) Refill engine oil and start engine 30 minutes after assembly is completed.

- Align rear oil seal retainer with dowel pins.
- Tighten the 6 bolts uniformly.

Rear oil seal retainer bolt tightening torque	6.3 - 8.3 N·m (0.64 - 0.85 kg·m, 4.6 - 6.1 ft·lb)
---	--

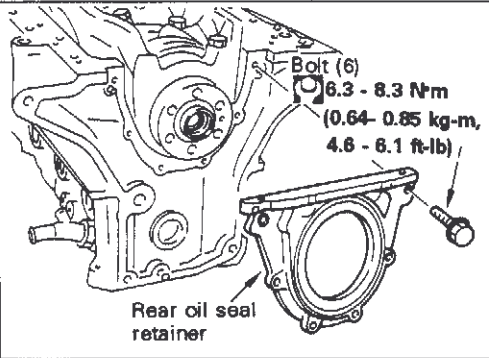

[Point 7] Rear oil seal removal and installation

Removal

- Use a screwdriver or suitable tool to remove the seal.

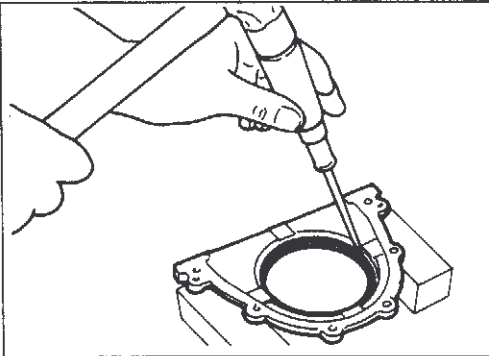

Installation

- Be careful not to scratch or damage the oil seal perimeter area. Use an oil seal drift [outside diameter: 100 mm (3.94 in)] to install new oil seal.
- Apply a coat of engine oil or chassis grease to oil seal lip perimeter area.

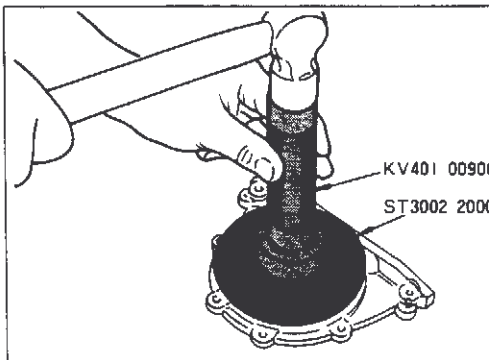

B2 RB26 DOHC EGI (ECCS) TWIN-TURBOCHARGER ENGINE

13. Engine Overhaul (Cont'd)

[Point 8] Connecting rod side clearance inspection

- Use a feeler gauge to measure the thrust clearance between the connecting rod and crank arm.

Unit: mm (in)

Standard	0.2 - 0.3 (0.008 - 0.012)
Limit	0.4 (0.016)

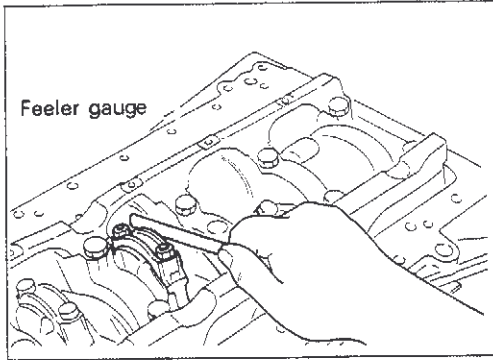

[Point 9] Piston and connecting rod ASSY removal and installation

- Use a hammer handle or similar tool to press unit to cylinder head side.

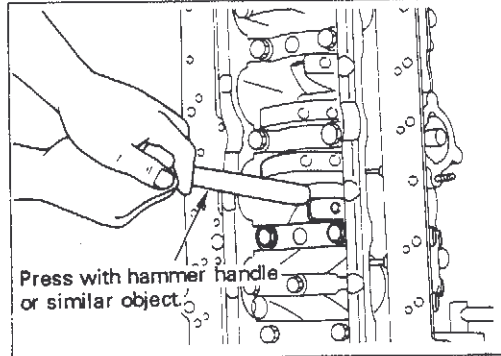

Installation

- Set crank pin at B.D.C. (bottom dead center) position.
- Coat cylinder bore, crank pin and piston with engine oil.
- Assemble piston with front mark on piston head facing the front of engine.
- Use a piston ring compressor to install piston and connecting rod assembly in cylinder block.

CAUTION:

Be careful not to strike or deform oil jet pipe with large end of connecting rod.

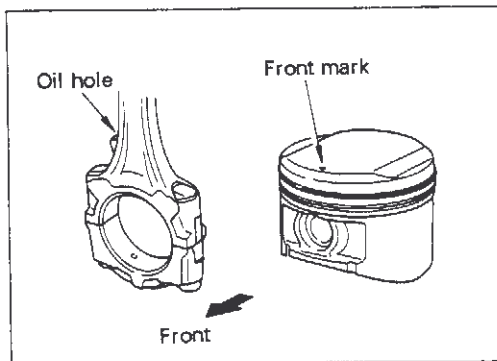
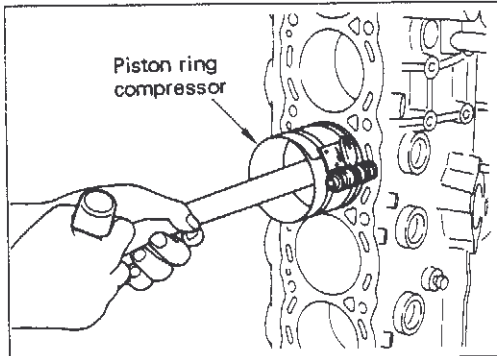

[Point 10] Connecting rod nut tightening

- Apply engine oil to connecting rods and nuts before assembly.
- Tighten nuts in two or three stages.

1st time	Torque wrench	14 - 16 N·m (1.4 - 1.6 kg-m, 10 - 12 ft-lb)
2nd time	Angle wrench (°)	60 - 65

CAUTION:

Do not use visual angle measurement for tightening torque if an angle wrench is not available.

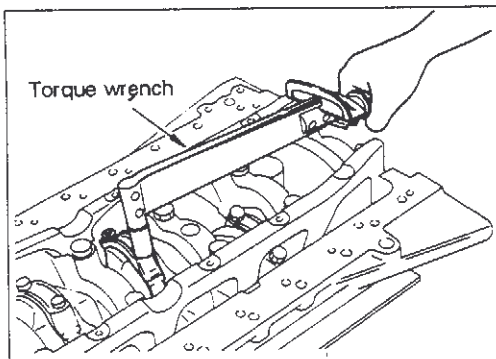

13. Engine Overhaul (Cont'd)

[Point 10] Connecting rod bearing installation

- Apply engine oil to bearing surfaces when assembling connecting rods and bearings. Do not apply engine oil to rear side of bearing, only clean this area.
- Align connecting rod bearing retainer notches and install.
- Align connecting rod oil holes and bearing oil holes.

[Point 11] Oil jet installation

- Set oil jet position securely and check that it does not interfere with piston.
- If oil jet pipe contacts piston or is bent, replace it with new part.

Oil jet tightening torque	30 - 40 N·m (3.1 - 4.1 kg·m, 22 - 30 ft·lb)
---------------------------	--

[Point 12] Piston ring removal and installation

Removal

- Use piston ring expander to remove rings.

CAUTION:

Be careful not to scratch piston.

Installation

- Use piston ring expander to install piston rings in correct position.

- The stamped marks on top and second piston ring openings must face up.

Position piston ring openings as shown in the figure on left and install.

CAUTION:

Be careful not to scratch piston.

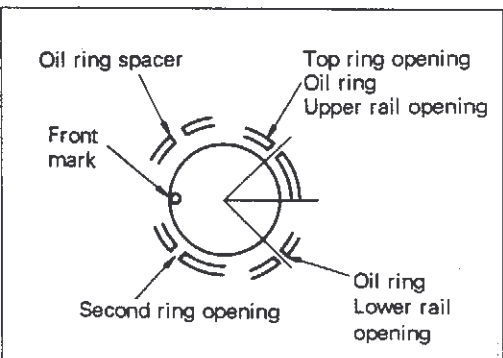
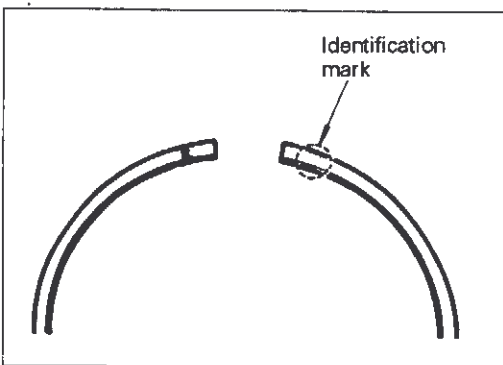
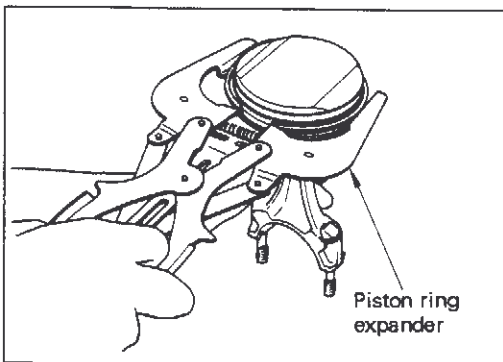
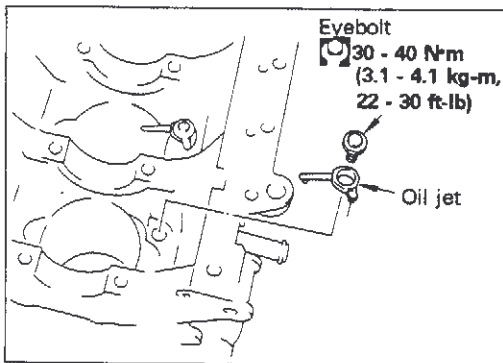
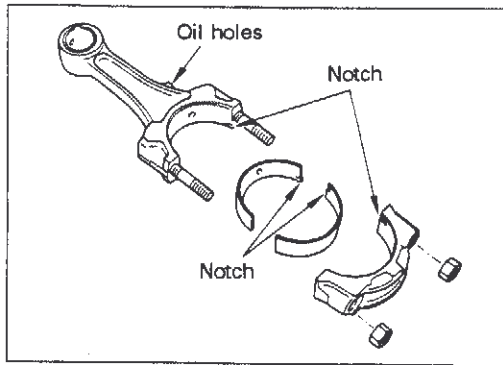

B2 RB26 DOHC EGI (ECCS) TWIN-TURBOCHARGER ENGINE

13. Engine Overhaul (Cont'd)

[Point 13] Snap ring removal and installation

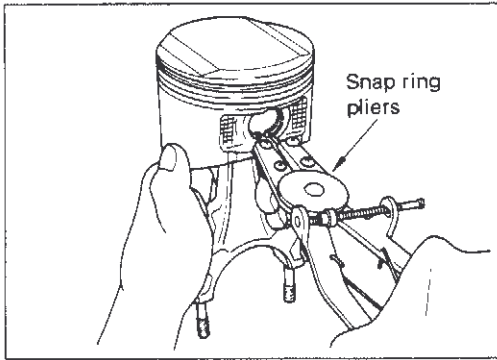

Removal

- Use snap ring pliers to remove rings.

Installation

- Use snap ring pliers and install ring securely in groove.

CAUTION:

Do not reuse snap rings.

[Point 14] Piston pin removal and installation

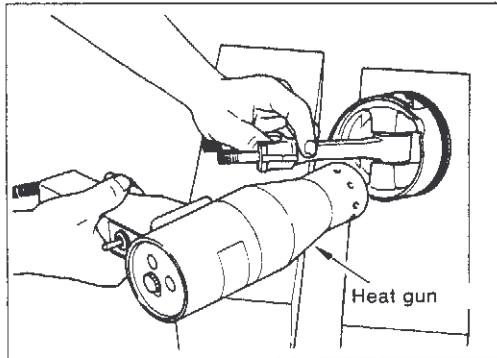

- When removing and installing piston pin, use a heat gun to heat piston to 60 to 70°C (140 to 158°F).

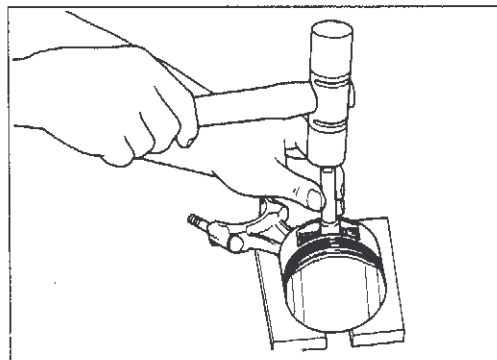

- Place suitable tool against piston pin and use press or plastic hammer.

Piston pin press-fit

- Apply a liberal amount of oil to pin, pin hole, and connecting rod small hole.

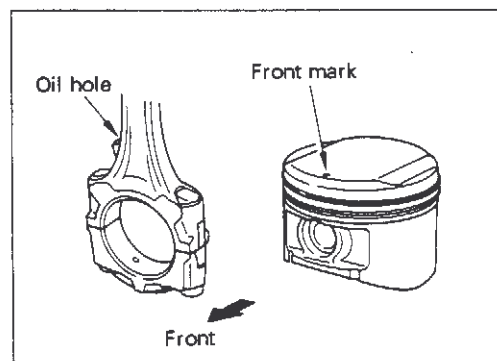

- Position piston front mark so the connecting rod oil hole faces right side of engine (left side when viewed from front) and press-fit.

CAUTION:

Press-fit piston pin from the front of piston to the rear side of piston.

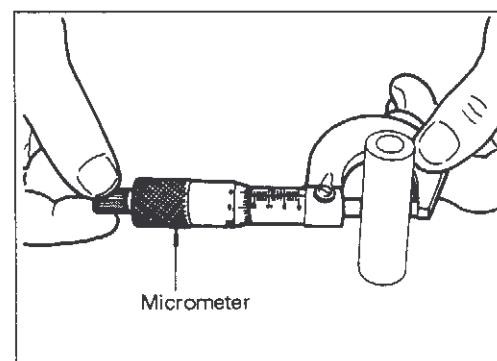

[Point 15] Piston pin inspection

- Measure outside diameter of piston pin with micrometer.

Standard	20.989 - 21.001 mm (0.8263 - 0.8268 in)
----------	--

B2 RB26 DOHC EGI (ECCS) TWIN-TURBOCHARGER ENGINE

13. Engine Overhaul (Cont'd)

[Point 16] Piston inspection

- Measure outside piston skirt diameter with micrometer.

Measuring point	Distance from bottom: 13 mm (0.51 in)
Standard	85.955 - 85.985 mm (3.3840 - 3.3852 in)

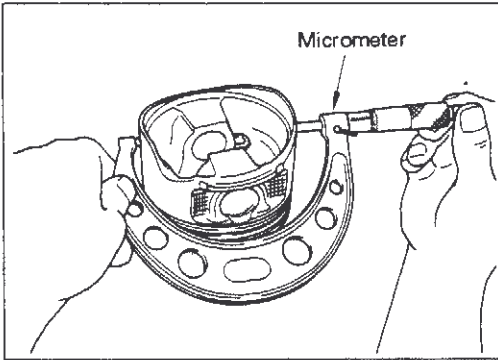

- Measure inside diameter of piston pin hole with inside micrometer.

Standard	20.987 - 20.999 mm (0.8263 - 0.8267 in)
----------	---

- Five types of pistons are available for service (STD1, STD2, STD3, 0.50S, 1.00S).

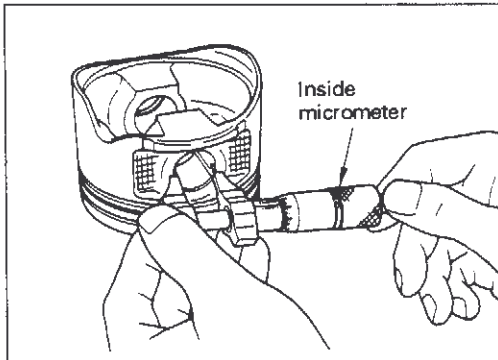

[Point 17] Piston pin clearance inspection

- Piston pin clearance is the figure obtained by subtracting the piston pin outside diameter [Point 15] from the piston pin hole inside diameter [Point 16].

Piston pin clearance at normal temperature [20°C (68°F)]	0 to -0.004 (0 to -0.0002 in)
--	-------------------------------

[Point 18] Connecting rod inspection

Bend and torsion inspection

- Measure the bend and torsion with connecting rod aligner.

Bend limit	0.15 mm (0.0059 in)
Torsion limit	0.3 mm (0.012 in)

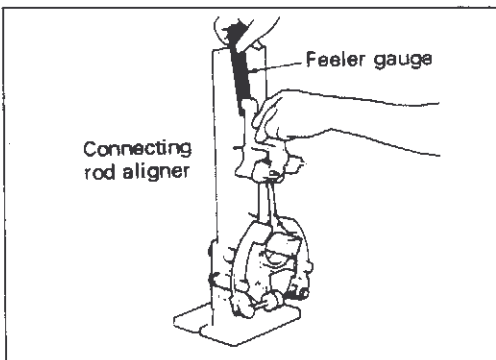

Small end inside diameter inspection

- Using an inside micrometer, measure inside diameter of connecting rod small end.

Standard	21.000 - 21.012 mm (0.8268 - 0.8272 in)
----------	---

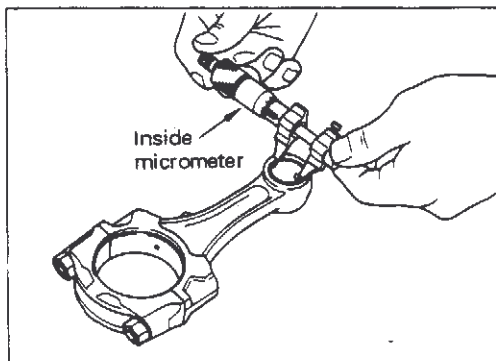

B2 RB26 DOHC EGI (ECCS) TWIN-TURBOCHARGER ENGINE

13. Engine Overhaul (Cont'd)

Connecting rod bearing inside diameter inspection

- Install connecting rod bearing in connecting rod and cap. Tighten connecting rod nuts to specified torque and measure connecting rod bearing inside diameter.

Connecting rod nut tightening torque	1st time	Torque wrench	14 - 16 N·m (1.4 - 1.6 kg-m, 10 - 12 ft-lb)
	2nd time	Angle wrench	60° - 65°
Standard value	47.989 - 48.007 mm (1.8893 - 1.8900 in)		

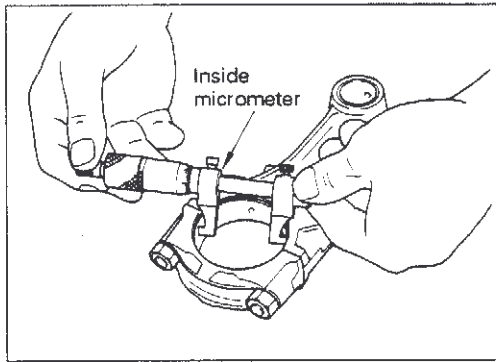

[Point 19] Connecting rod small end bushing clearance

- The measurement difference of the small end inside diameter [Point 18] and outside diameter of piston pin [Point 15] is the bushing clearance. (Full float type)

Bushing clearance standard	0.005 - 0.017 mm (0.0002 - 0.0007 in)
----------------------------	---------------------------------------

- The connecting rod small end and piston pin outside diameter are separated into two grades at the factory. Check that the grades (0.1) conform for both parts because the rod and pin are selected and fitted according to bushing clearance.

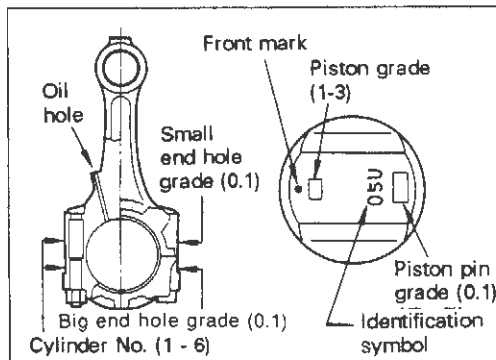

[Point 20] Connecting rod cap bolts

- Connecting rod cap bolts have grooves to prevent them from disengaging.
- For this reason, do not tap the ends to remove bolts.

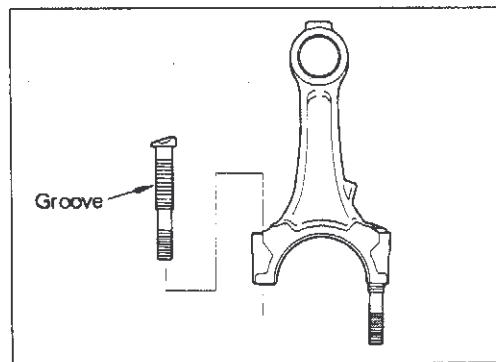

[Point 21] Piston ring end gap and side clearance

Ring end gap inspection

- Using a piston, press the piston ring into the middle of the cylinder, and measure the gap.

Item	Part	Top ring	2nd ring	Oil ring
Standard mm (in)	Bore grade 1, 2, 3: 0.24 - 0.34 (0.0094 - 0.0134)	0.42 - 0.57 (0.0165 - 0.0224)	0.20 - 0.60 (0.0079 - 0.0236)	

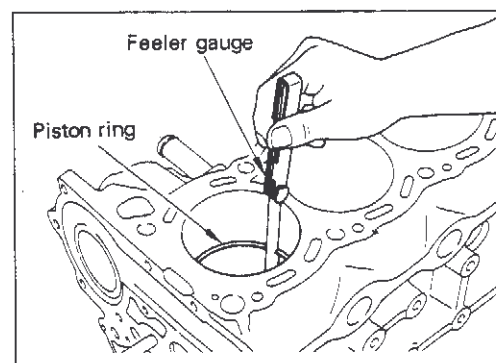

Side clearance inspection

- Measure the clearance between piston ring and piston ring groove.

Item	Part	Top ring	2nd ring	Oil ring
Standard mm (in)		0.040 - 0.075 (0.0016 - 0.0030)	0.030 - 0.065 (0.0012 - 0.0026)	0.065 - 0.135 (0.0026 - 0.0053)

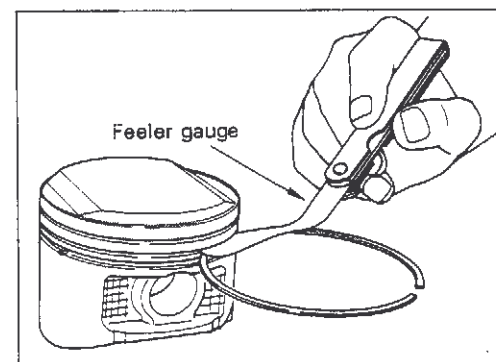

- Three types of piston rings (STD, 0.50S, 1.00S) are available for service.

B2 RB26 DOHC EGI (ECCS) TWIN-TURBOCHARGER ENGINE

13. Engine Overhaul (Cont'd)

[Point 22] Crankshaft thrust clearance inspection

- Use a feeler gauge to measure the clearance between the thrust bearing (No. 4 bearing) and the crank arm when moving the crankshaft toward front and rear of engine.

Standard	0.05 - 0.18 mm (0.0020 - 0.0071 in)
Limit	0.3 mm (0.012 in)

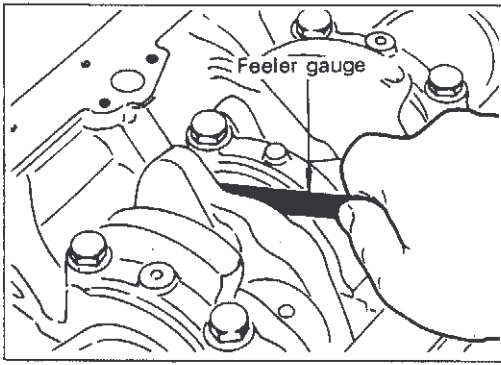

[Point 23] Pilot bushing removal and installation

Removal

- Use a pilot bearing puller to remove pilot bushing.

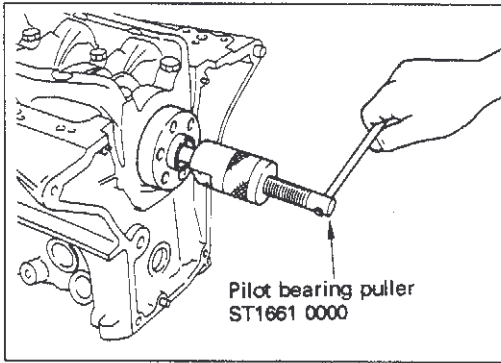

Installation

- The pilot bushing installation position is shown in figure on left.

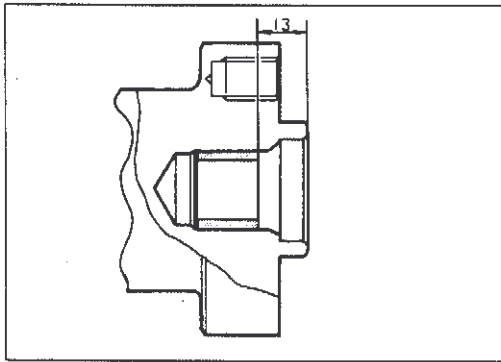

[Point 24] Main bearing bolt removal and installation

Removal

- Remove bearing bolts in reverse order of numbered sequence shown in the figure.

Installation

- Tighten the bearing bolts to the specified torque in two or three steps in the sequence shown in the figure. After tightening to the specified torque, check that crankshaft turns smoothly.

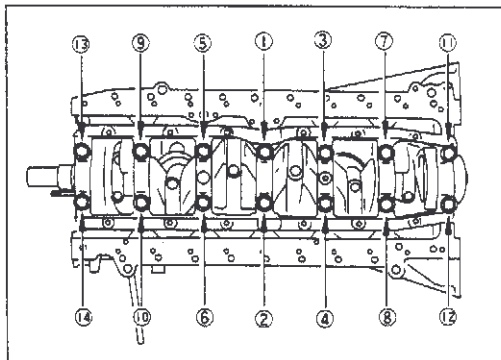

Main bearing bolt tightening torque	46 - 52 N·m (4.7 - 5.3 kg-m, 34 - 38 ft-lb)
-------------------------------------	---

CAUTION:

Apply a coating of engine oil to the bolt threads and bolt seats.

B2 RB26 DOHC EGI (ECCS) TWIN-TURBOCHARGER ENGINE

13. Engine Overhaul (Cont'd)

[Point 25] Main bearing cap removal and installation

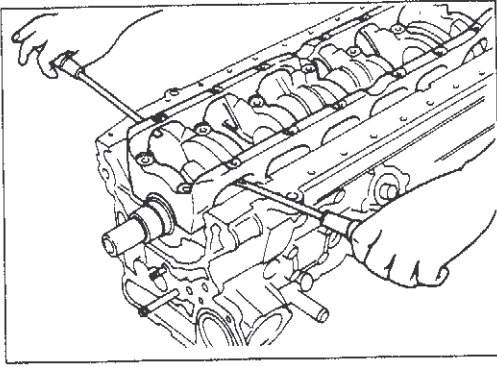

Removal

- Use screwdrivers to pry the bearing caps open.

CAUTION:

Be careful not to scratch the oil pan rail surface.

Installation

- Position main bearing cap ensuring the installation direction, then fit onto cylinder block by lightly tapping it in a number of locations with a copper hammer or suitable tool.

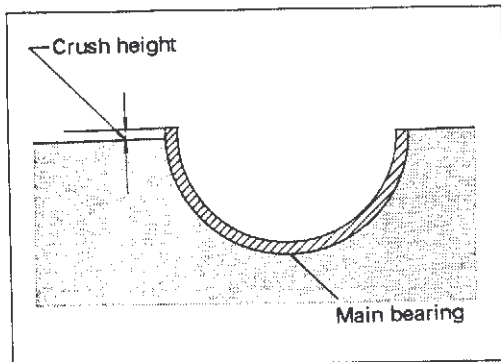

[Point 26] Main bearing inspection

- The bearing end should protrude when installed in main bearing cap or cylinder block.

This protrusion is called the crush height.

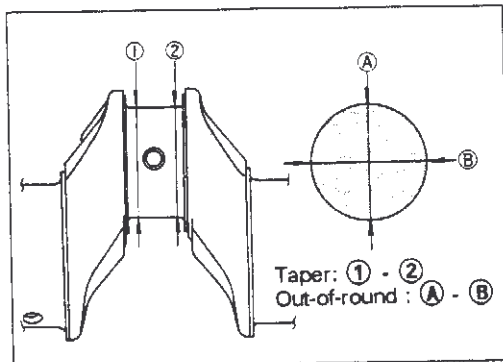

[Point 27] Crankshaft inspection

Out-of-round and taper inspection

- Use a micrometer to check each journal (No. 1 to No. 7) and each pin (No. 1 to No. 6) in four locations shown in the figure.
- The out-of-round value is the difference of the dimensions in directions **A** and **B**.
- The taper value is the difference of the dimensions measured at points **1** and **2**.

Out-of-round and taper limit	0.005 mm (0.0002 in)
------------------------------	----------------------

Pin and journal inspection

- Use a micrometer to measure pin and journal diameters.

Pin diameter standard	47.961 - 47.974 mm (1.8882 - 1.8887 in)
Journal diameter standard	54.951 - 54.975 mm (2.1634 - 2.1644 in)

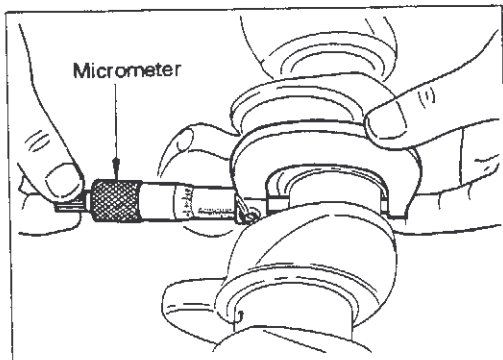

B2 RB26 DOHC EGI (ECCS) TWIN-TURBOCHARGER ENGINE

13. Engine Overhaul (Cont'd)

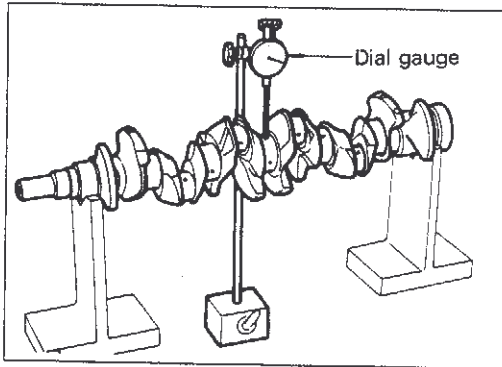

Curve inspection

- Use V-blocks on a fixed surface and support journals on both ends of crankshaft (No. 1 and No. 7).
- Position the dial gauge vertically on middle of No. 4 journal as shown.
- Turn crankshaft by hand in one direction and read dial gauge movement.
- The runout is equal to one-half of dial gauge movement.

Limit	0.05 mm (0.0020 in)
-------	---------------------

[Point 28] Connecting rod bearing oil clearance inspection

Method A (using inside micrometer and micrometer)

- The oil clearance can be calculated from the connecting rod bearing inside diameter and the crankshaft pin diameter measured in [Point 18] and [Point 27].
 $(\text{oil clearance}) = (\text{bearing inside diameter}) - (\text{crankshaft pin diameter})$

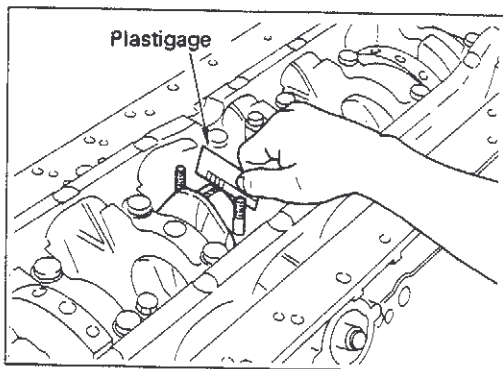

Method B (using plastigage)

- Remove all dust from crankshaft pins and bearing surfaces
- Cut off a piece of plastigage slightly shorter than the bearing width. Place the plastigage on crankshaft in direction of axis, being careful not to place on oil hole.
- Assemble connecting rod bearing in connecting rod cap and tighten connecting rod nuts to specified torque.

Connecting rod nut tightening torque	1st time	Torque wrench	14 - 16 N·m (1.4 - 1.6 kg-m, 10 - 12 ft-lb)
	2nd time	Angle wrench (°)	60 - 65

CAUTION:

Do not turn crankshaft or connecting rod while plastigage is being inserted.

- Remove connecting rod cap and bearing. Measure plastigage width with plastigage scale.

Standard	0.020 - 0.040 mm (0.0008 - 0.0016 in)
Limit	0.090 mm (0.0035 in)

- If the oil clearance exceeds the limit, refer to [Point 29] and select the appropriate bearing.

B2 RB26 DOHC EGI (ECCS) TWIN-TURBOCHARGER ENGINE

13. Engine Overhaul (Cont'd)

[Point 29] Connecting rod bearing selection and engaging

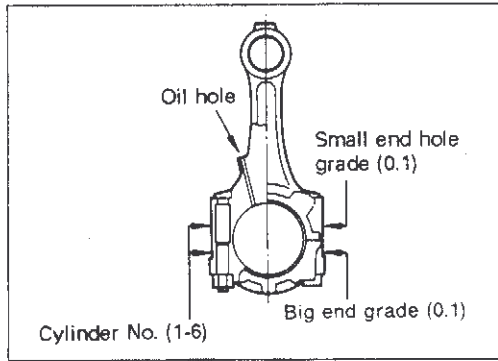

- Select the proper sized bearing because connecting rod bearing prevents fluctuation in the oil clearance. Three bearing thicknesses are available to fit the inside diameter of the big end of connecting rod and the crank pin diameter grade.
- When replacing connecting rod bearing, check big end inside diameter grade (indicated on the opposite side of connecting rod oil hole) and the pin diameter grade (indicated on crankshaft No. 1 counterweight front surface). Select connecting rod bearing with proper thickness according to the following table.

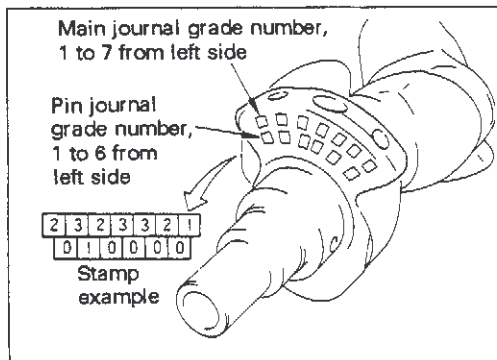

Connecting rod bearing selection chart

Unit: mm (in)

Connecting rod large end inside diameter	Less than 51.007 (2.0081) 51.000 (2.0079) max.		51.013 (2.0084) max. 51.007 (2.0081) min.
	Crank pin diameter	Grade number stamp	
47.974 (1.8887) max. Greater than 47.968 (1.8885)	0	Bearing grade No.: STD 0 Bearing thickness: 1.500 - 1.503 (0.0591 - 0.0592) Oil clearance: 0.020/ 0.039 (0.0008/0.0015) Identification color: None	STD 1 1.503 - 1.506 (0.0592 - 0.0593) 0.021/0.039 (0.0008/0.0015) Brown
47.968 (1.8885) max. 47.961 (1.8882) min.	1	STD 1 1.503 - 1.506 (0.0592 - 0.0593) 0.020/0.040 (0.0008/0.0016) Brown	STD 2 1.506 - 1.509 (0.0593 - 0.0594) 0.021/0.040 (0.0008/0.0016) Green

B2 RB26 DOHC EGI (ECCS) TWIN-TURBOCHARGER ENGINE

13. Engine Overhaul (Cont'd)

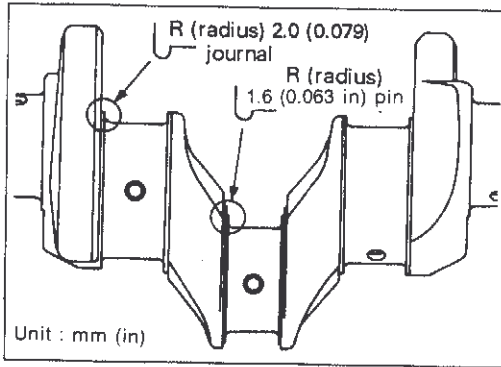

- When using undersize bearings, measure bearing inside diameter when bearing is installed. Grind pin so oil clearance conforms to specified value.

Unit: mm (in)		
Size	Thickness	Grade No.
US0.08 (0.0031)	1.541/1.549 (0.0607/0.0610)	8
US0.12 (0.0047)	1.561/1.569 (0.0615/0.0618)	12
US0.25 (0.0098)	1.626/1.634 (0.0640/0.0643)	25

CAUTION:

Be careful not to scratch fillet roll when the crank pin is being ground for use with undersize bearing.

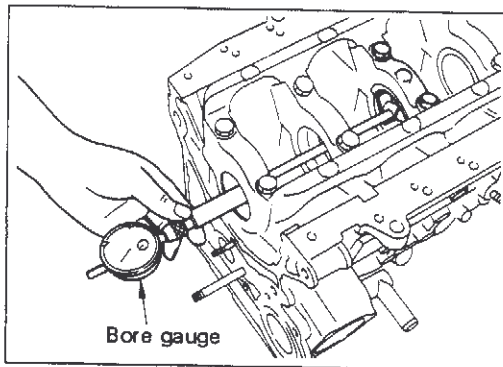

[Point 30] Main bearing oil clearance

Method A (using bore gauge and micrometer)

- Install main bearing in cylinder block and attach bearing cap. Tighten bearing cap bolts to specified torque and measure bearing inside diameter.

Bearing cap bolt tightening torque	46 - 52 N·m (4.7 - 5.3 kg-m, 34 - 38 ft-lb)
------------------------------------	---

- The oil clearance distance can be calculated from the values for the outside diameter of crank journal measured in [Point 27].
 $(\text{Oil clearance}) = (\text{bearing inside diameter} - (\text{crankshaft outside diameter}))$

B2 RB26 DOHC EGI (ECCS) TWIN-TURBOCHARGER ENGINE

13. Engine Overhaul (Cont'd)

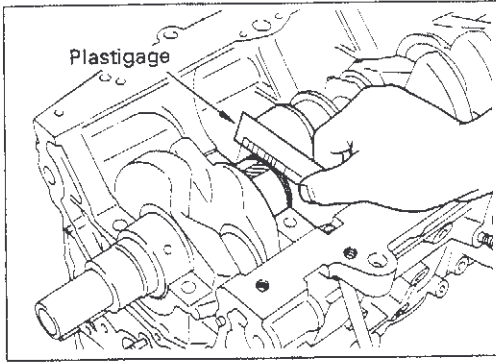

Standard	0.028 - 0.047 mm (0.0011 - 0.0019 in)
Limit	0.090 mm (0.0035 in)

- If oil clearance exceeds limit value, refer to [Point 31] and select suitable bearing.

Method B (using plastigage)

- Remove all dust and oil from each crankshaft journal and bearing surface.
- Cut off a piece of plastigage slightly shorter than the bearing width. Place the plastigage on crankshaft in direction of axis, being careful not to place on oil hole.
- Assemble main bearing and bearing cap. Install bearing cap onto cylinder block and tighten cap bolts to the specified torque.

Bearing cap bolt tightening torque	46 - 52 N·m (4.7 - 5.3 kg-m, 34 - 38 ft-lb)
------------------------------------	---

CAUTION:

Do not turn crankshaft while plastigage is being inserted.

- Remove bearing cap and bearing. Measure plastigage width on plastigage scale.

CAUTION:

If excessive bearing clearance still exists, use a thicker main bearing or undersized bearing so that the specified bearing clearance is obtained when measured by Method A as well.

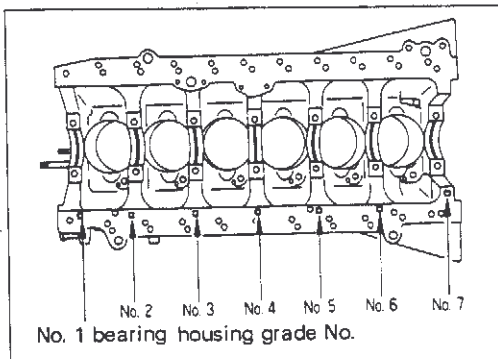

[Point 31] Main bearing selection and engagement

- Select the proper sized bearing because main bearing prevents fluctuation in the oil clearance. Seven bearing thicknesses are available to fit the cylinder block bearing housing and crank journal diameter grade.

Note: Selection engagement is performed only for standard size.

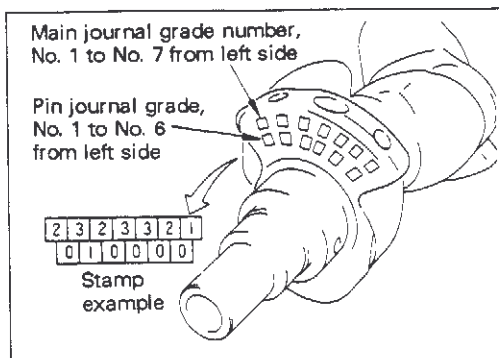

- When replacing main bearing, check the bearing grade (indicated on bottom face of cylinder block) and journal diameter grade (indicated on crankshaft No. 1 counterweight front surface). Select main bearing with proper thickness according to the following table.

B2 RB26 DOHC EGI (ECCS) TWIN-TURBOCHARGER ENGINE

13. Engine Overhaul (Cont'd)

Main bearing selection table

Unit: mm (in)

Cylinder block bearing housing inner diameter	Grade No. stamp	58.651 (2.3091)	58.657 (2.3093)	58.663 (2.3096)	58.670 (2.3098)	
		Max. Greater than 58.645 (2.3089)	Max. Greater than 58.651 (2.3091)	Max. Greater than 58.657 (2.3093)	Max. Greater than 58.663 (2.3096)	
Crankshaft journal diameter		0	1	2	3	
54.975 (2.1644) Max. Greater than 54.969 (2.1641)	0	Bearing grade No.	STD 0	STD 1	STD 2	STD 3
		Bearing thickness	1.818 - 1.821 (0.0716 - 0.0717)	1.821 - 1.824 (0.0717 - 0.0718)	1.824 - 1.827 (0.0718 - 0.0719)	1.827 - 1.830 (0.0719 - 0.0720)
		Oil clearance	0.028/0.046 st.0011/0.0018)	0.028/0.046 (0.0011/0.0018)	0.028/0.046 (0.0011/0.0018)	0.028/0.047 (0.0011/0.0019)
		Identification color	Black	Brown	None	Yellow
54.969 (2.1641) Max. Greater than 54.963 (2.1639)	1	Bearing grade No.	STD 1	STD 2	STD 3	STD 4
		Bearing thickness	1.821 - 1.824 (0.0717 - 0.0718)	1.824 - 1.827 (0.0718 - 0.0719)	1.827 - 1.830 (0.0719 - 0.0720)	1.830 - 1.833 (0.0720 - 0.0722)
		Oil clearance	0.028/0.046 (0.0011/0.0018)	0.028/0.046 (0.0011/0.0018)	0.028/0.046 (0.0011/0.0018)	0.028/0.047 (0.0011/0.0019)
		Identification color	Brown	None	Yellow	Blue
54.963 (2.1639) Max. Greater than 54.957 (2.1637)	2	Bearing grade No.	STD 2	STD 3	STD 4	STD 5
		Bearing thickness	1.824 - 1.827 (0.0718 - 0.0719)	1.827 - 1.830 (0.0719 - 0.0720)	1.830 - 1.833 (0.0720 - 0.0722)	1.833 - 1.836 (0.0722 - 0.0723)
		Oil clearance	0.028/0.046 (0.0011/0.0018)	0.028/0.046 (0.0011/0.0018)	0.028/0.046 (0.0011/0.0018)	0.028/0.047 (0.0011/0.0019)
		Identification color	None	Yellow	Blue	Green
54.957 (2.1637) Max. Greater than 54.951 (2.1634)	3	Bearing grade No.	STD 3	STD 4	STD 5	STD 6
		Bearing thickness	1.827 - 1.830 (0.0719 - 0.0720)	1.830 - 1.833 (0.0720 - 0.0722)	1.833 - 1.836 (0.0722 - 0.0723)	1.836 - 1.839 (0.0723 - 0.0724)
		Oil clearance	0.028/0.046 (0.0011/0.0018)	0.028/0.046 (0.0011/0.0018)	0.028/0.046 (0.0011/0.0018)	0.028/0.047 (0.0011/0.0019)
		Identification color	Yellow	Blue	Green	Pink

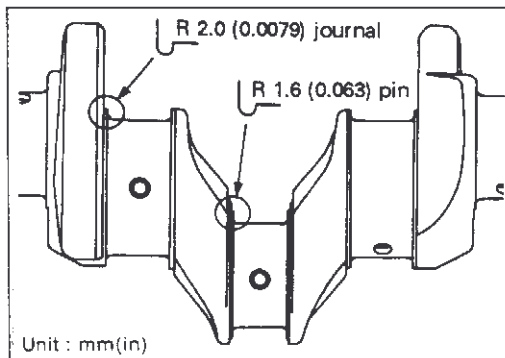

- When using undersize bearings, measure bearing inside diameter when bearing is installed and grind journal so oil clearance conforms to specified clearance.

Unit: mm (in)

Size	Thickness	Grade No.
US0.25 (0.0098)	1.950/1.958 (0.0768/0.0771)	25

CAUTION:

When crankshaft journal is being ground for use with undersize bearings, do not scratch the fillet roll.

B2 RB26 DOHC EGI (ECCS) TWIN-TURBOCHARGER ENGINE

13. Engine Overhaul (Cont'd)

[Point 32] Cylinder block inspection and correction

- Remove all oil and water deposits, gasket, seal material and carbon from cylinder block.

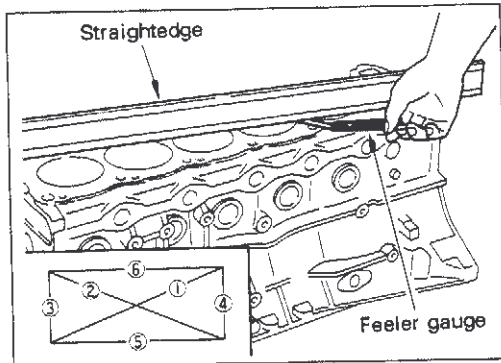
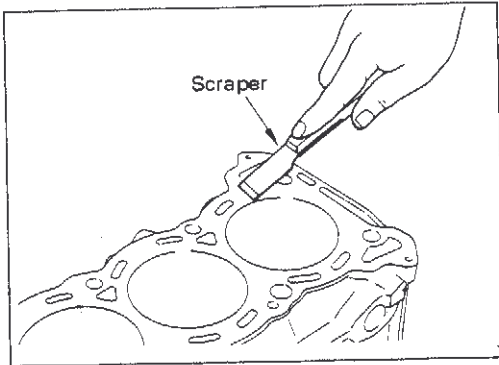

Upper surface distortion and wear inspection

- Clean upper face of cylinder block and measure the distortion in six directions.

Limit	0.1 mm (0.004 in)
-------	-------------------

- If the distortion exceeds the specified limit, resurface face with surface grinder or replace block if necessary.

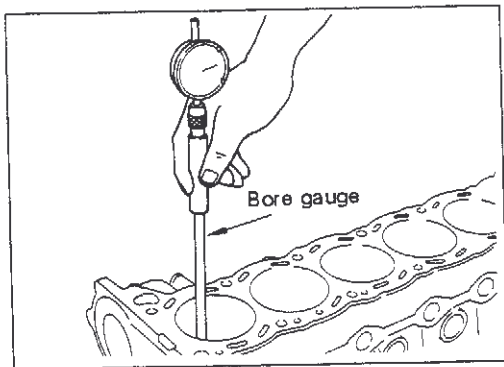

Cylinder inside diameter inspection

- Use bore gauge and measure cylinder bore for wear, out-of-round and taper. Measure in three vertical locations (A, B, C) and two directions (X, Y) for a total of six locations.

Unit: mm (in)

Cylinder inside diameter standard	86.000 - 86.050 (3.3858 - 3.3878)
Wear limit	0.2 (0.008)
Out-of-round limit	0.015 (0.0006)
Taper limit	0.010 (0.0004)

- Out-of-round measurement is difference of measurement in two directions (X, Y).
- Taper is difference of measurement at top and bottom (A, C).

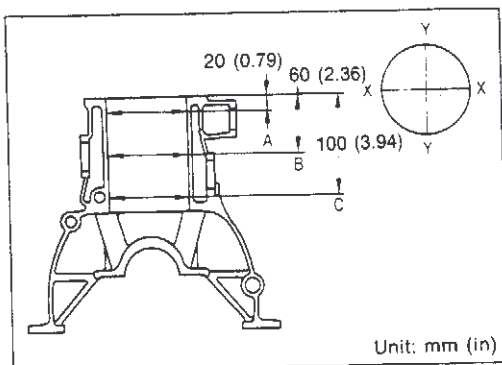

Unit: mm (in)

- Perform honing or boring when abnormality is inspected.

B2 RB26 DOHC EGI (ECCS) TWIN-TURBOCHARGER ENGINE

13. Engine Overhaul (Cont'd)

Cylinder honing

- There are three types of oversize pistons, STD (standard - 0.02), OS (0.5) and OS (1.0). When oversize pistons are used, hone the cylinder so the clearance between piston and cylinder conforms to the specified value described in [Point 33]. Oversize piston rings must be used that fit the oversize piston.

[Point 33] Piston-to-cylinder bore clearance

- The clearance can be calculated from the measured value for the piston skirt outside diameter [Point 16] and cylinder inside diameter [Point 32] (X direction B location).
(Clearance) = (cylinder inside diameter) — (piston skirt outside diameter)

Standard at normal temperature	0.035 - 0.055 mm (0.0014 - 0.0022 in)
--------------------------------	---------------------------------------

B3 ECCS (Electronically Concentrated Engine Control System)

Tools required

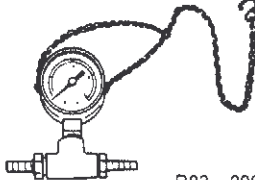
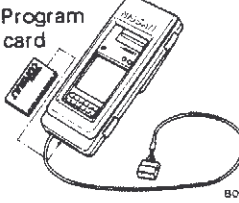
	Name		Application
Measurement tool	EGL fuel pressure gauge ST1959 0000	 B02-0064	Fuel pressure measurement
	Circuit tester		Resistance, voltage measurement
	Handy vacuum pump EG1513 000		Part inspection
	Engine tachometer		Engine speed inspection
	Electronic system diagnosis tester CONSULT EG1180 0000	 Program card B09-0001	System inspection, diagnosis
	Check adapter II EG1771 0000		Control unit input and output signal inspection
	Oscilloscope		

B3 ECCS (Electronically Concentrated Engine Control System)

1. Trouble Diagnosis

1-1 TROUBLE DIAGNOSTIC PROCEDURE

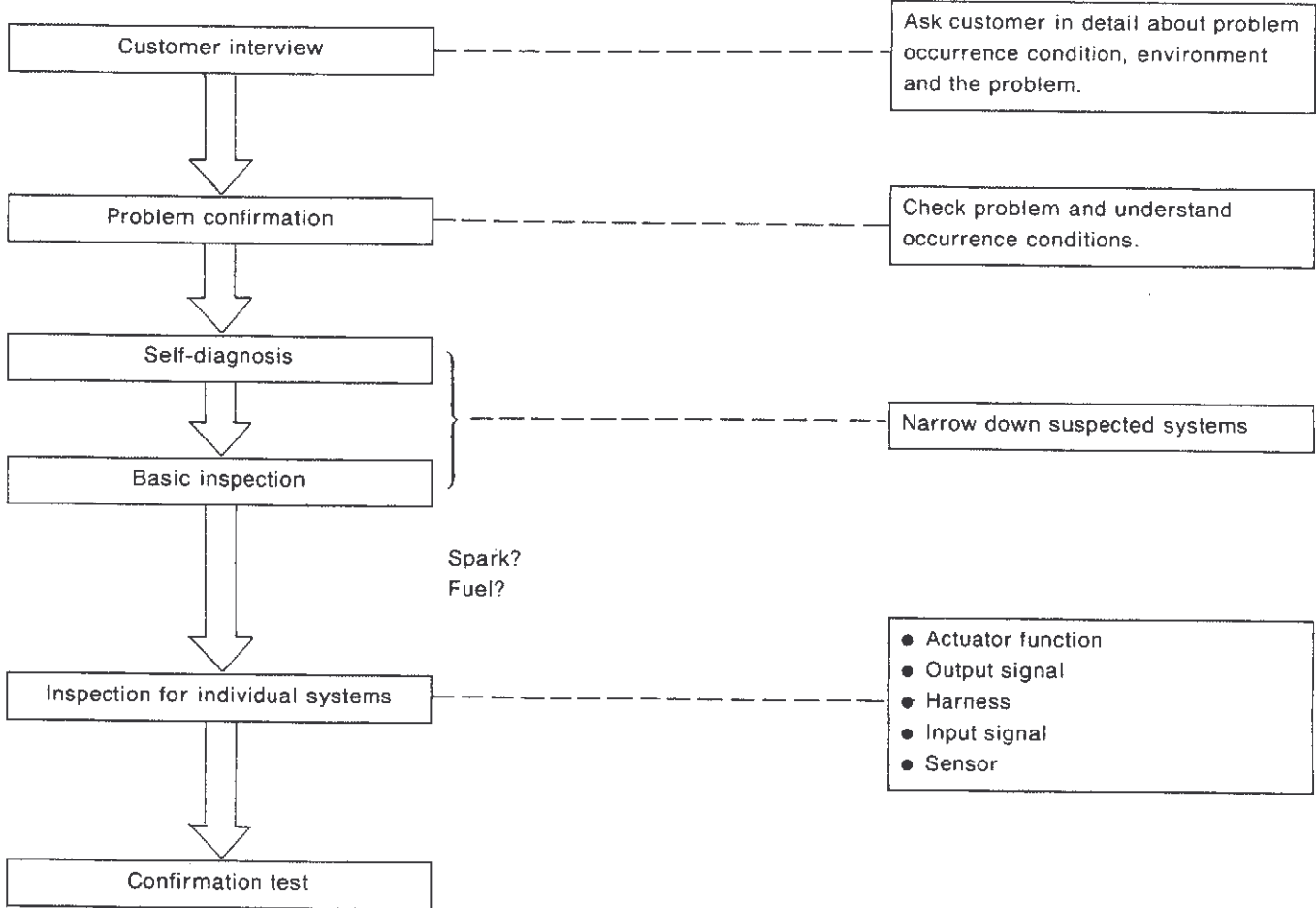

CAUTION:

Engine problems are roughly divided into two types: problems relating to engine main body and those related to control system. This section explains the trouble diagnostic method for the control system under the assumption that the engine main body is normal. Consequently, attention should also be paid to the condition of the engine main body and gasoline quality.

B3 ECCS (Electronically Concentrated Engine Control System)

1. Trouble Diagnosis (Cont'd)

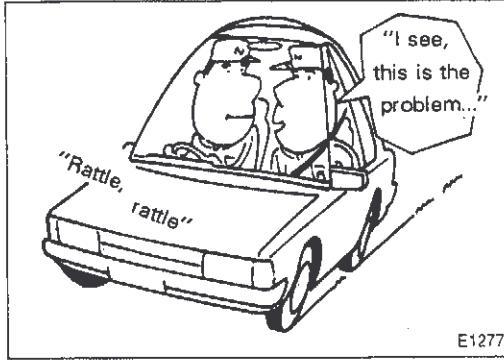

(2) Problem confirmation

- Customer's explanation is often insufficient in clarifying the status of the problem. Reproduction of the problem on the actual car and its confirmation and analysis are therefore essential. If unable to reproduce the problem, ask the customer in detail about its occurrence conditions and try to reproduce it under the indicated conditions. If unable to reproduce, manually shake the concerned harness to check for poor contact or other problems.
- It is also recommended to collect and analyze the data using CONSULT while driving.
- When checking the actual vehicle, record data on normal portions to assist in diagnosing a problem.

(3) Self-diagnosis

- If problems are attributable to the ECCS signal system, problem diagnosis should be narrowed down using the self-diagnostic function.

● What happened up to present?	Self-diagnosis
● How about the signal system at present?	Real-time diagnosis or switch ON/OFF diagnosis using the CONSULT "Data Monitor" function.

(4) Basic inspection

- Check if the three elements of combustion are functioning normally. Find out which system is faulty; fuel system, ignition system or idling control system.

● Fuel?	Are injector and fuel pump operating?
● Ignition?	Are sparks present?
● Idling control?	Is AAC valve operating?
● Air-fuel ratio?	Is air-fuel ratio feedback function normal?

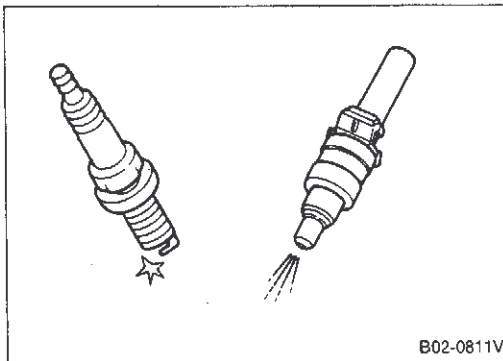

B3 ECCS (Electronically Concentrated Engine Control System)

1. Trouble Diagnosis (Cont'd)

(5) Individual system inspection

An efficient method for ECCS diagnosis is to check the control unit output signals first. Continue by checking individual parts such as actuators and sensors as well as input signals according to the results of the output signal check.

[Procedure]

Note: The input data must be monitored first when using CONSULT.
(Only checking the output data does not provide accurate results.)

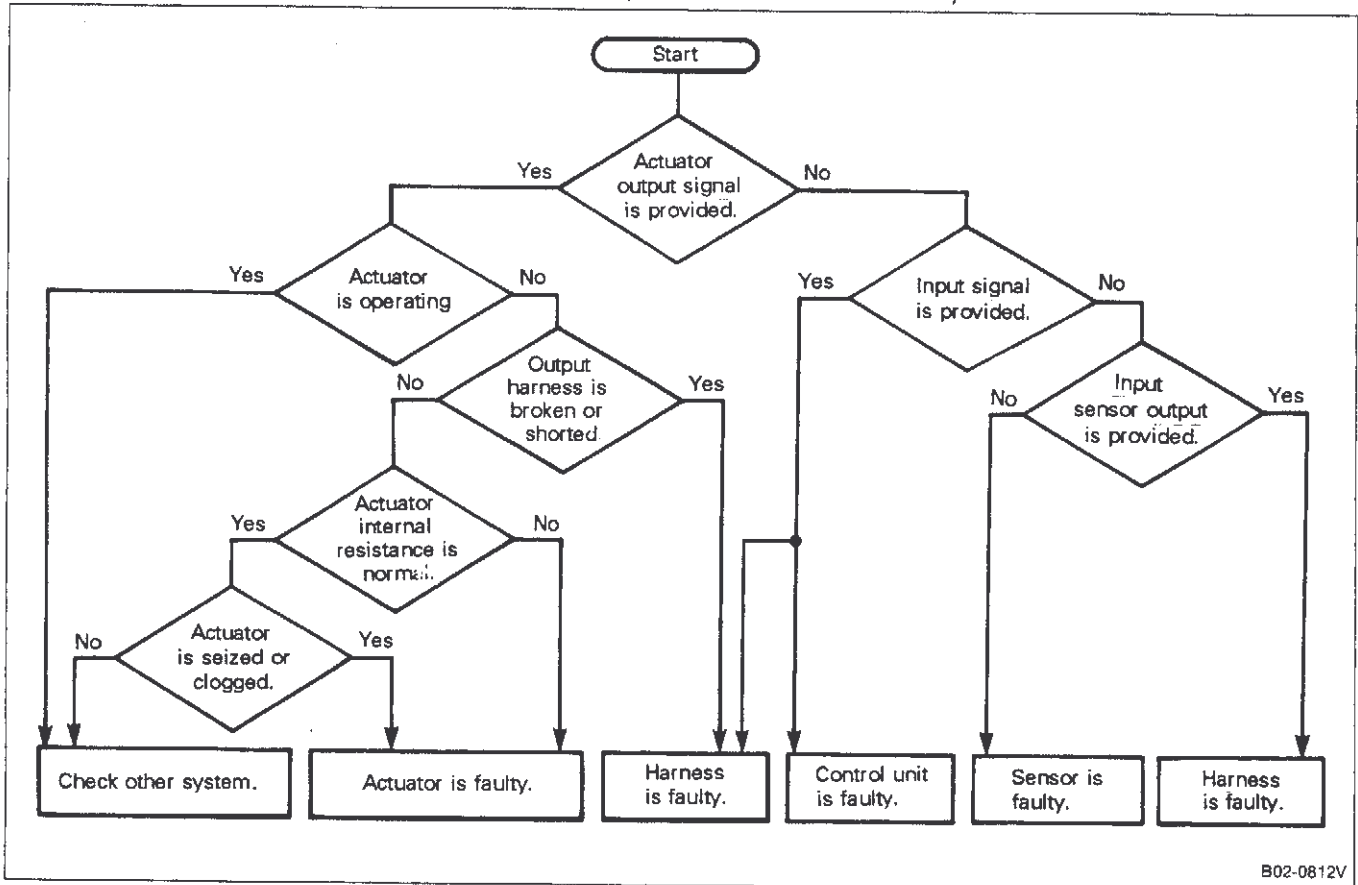

B02-0812V

B3 ECCS (Electronically Concentrated Engine Control System)

1. Trouble Diagnosis (Cont'd)

[Analysis]

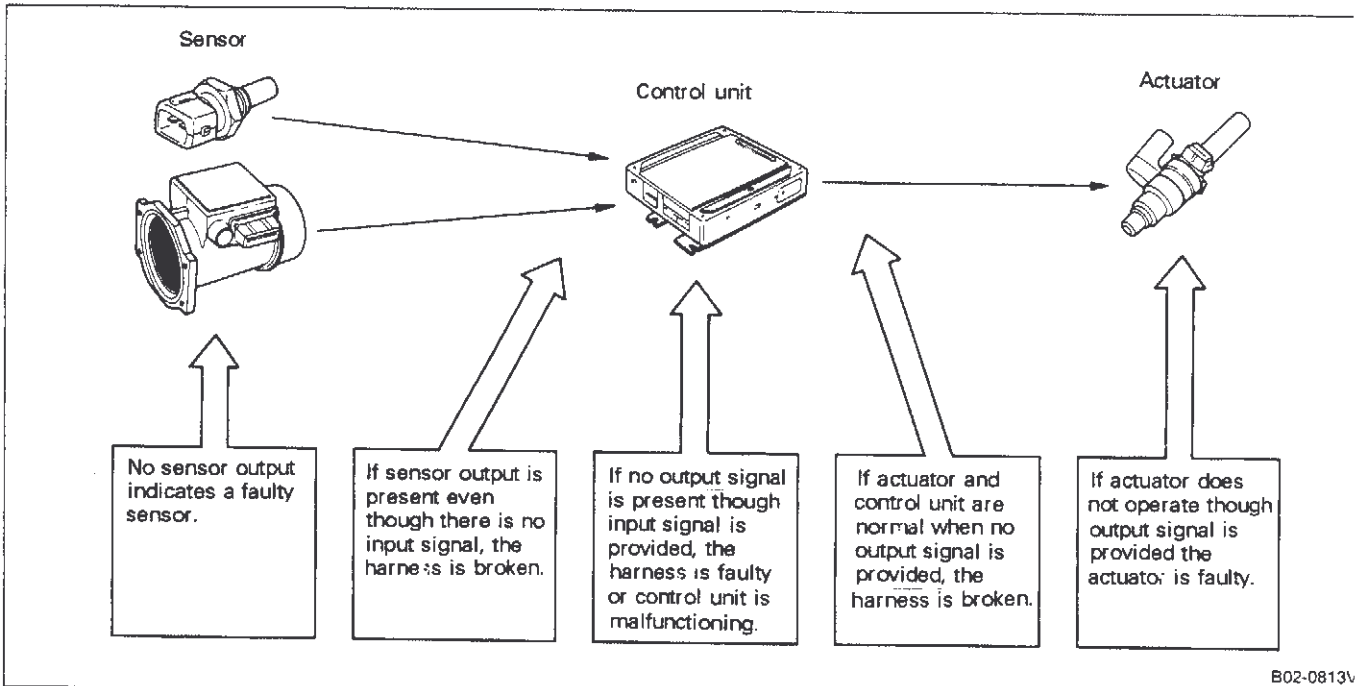

B02-0813v

B3 ECCS (Electronically Concentrated Engine Control System)

1. Trouble Diagnosis (Cont'd)

(6) Trouble diagnosis using measuring instruments (Operations in square frames to be performed with CONSULT.)

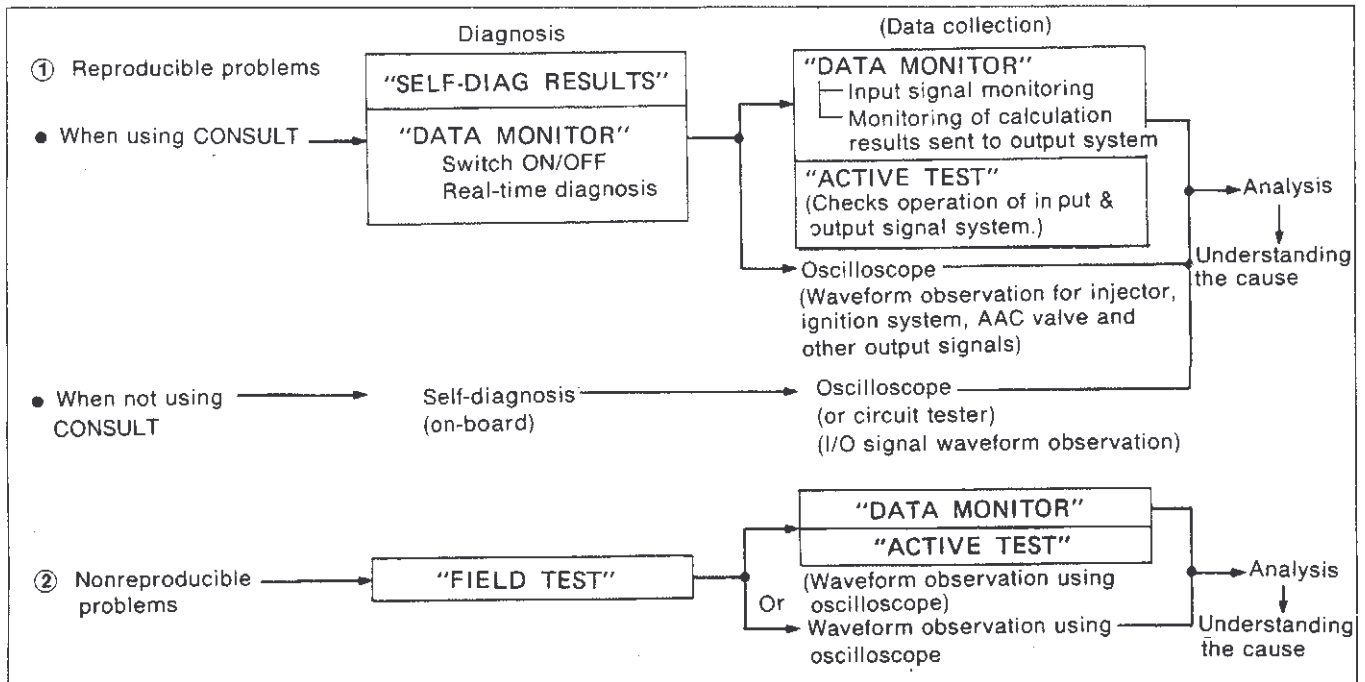

B3 ECCS (Electronically Concentrated Engine Control System)

1. Trouble Diagnosis (Cont'd)

1-2 MAJOR ECCS INPUT SIGNALS AND CONTROL ITEMS

Understanding the relationship between the input signals and control items (output) of ECCS is essential to efficiently determine the cause of problems.

Input \ Output	Fuel injection control (injector)	Ignition control (power transistor, IGN coil)	Idle control (ACC valve)
Crank angle sensor 120° signal	<ul style="list-style-type: none"> ● Determination of injector injection timing ● Engine rpm input signal 	<ul style="list-style-type: none"> ● Ignition timing start point 	<ul style="list-style-type: none"> ● Engine rpm input signal
Crank angle sensor 1° signal	<ul style="list-style-type: none"> ● Engine speed input signal 	<ul style="list-style-type: none"> ● Ignition timing count 	<ul style="list-style-type: none"> ● Engine speed input signal
Air flow meter	<ul style="list-style-type: none"> ● Intake air volume measurement and control of injector injection pulse width 	<ul style="list-style-type: none"> ● Ignition timing control 	
Engine temperature sensor	<ul style="list-style-type: none"> ● Engine temperature enrichment correction ● Fuel cut range change 	<ul style="list-style-type: none"> ● Ignition timing alteration due to water temperature 	<ul style="list-style-type: none"> ● Target speed change according to water temperature
Start signal	<ul style="list-style-type: none"> ● Start time enrichment 	<ul style="list-style-type: none"> ● Ignition timing control during cranking 	
Throttle sensor	<ul style="list-style-type: none"> ● Fuel injection interrupt ● Enrichment correction during acceleration and deceleration ● Fuel cut judgment during speed change control ● Intake air volume measurement 		
Soft idle switch (idle judgment by throttle opening angle)	<ul style="list-style-type: none"> ● Fuel cut due to ON signal ● ON* → OFF time enrichment 	<ul style="list-style-type: none"> ● Ignition timing change 	<ul style="list-style-type: none"> ● Idle control start by ON signal

Note *: Throttle sensor judges ON-OFF time instead of idle contact. During the ON time, fully closed throttle or "fully closed throttle + α (partially open)" throttle is detected. (The idle contact is used as backup system if throttle sensor problem occurs.)

B3 ECCS (Electronically Concentrated Engine Control System)

1. Trouble Diagnosis (Cont'd)

Input \ Output	Fuel injection control (injector)	Ignition control (power transistor, IGN coil)	Idle control (ACC valve)
Vehicle speed sensor	<ul style="list-style-type: none"> ● Fuel cut changeover vehicle speed ● Fuel cut at 0 km/h (0 MPH) vehicle speed ● Transmission shift position judgment 		<ul style="list-style-type: none"> ● Idle control start at vehicle speed below 8 km/h (5 MPH)
Exhaust gas sensor	<ul style="list-style-type: none"> ● Pulse width control by air-fuel ratio feedback 		
Detonation sensor		<ul style="list-style-type: none"> ● Ignition timing change 	
Battery voltage	<ul style="list-style-type: none"> ● Pulse width correction 	<ul style="list-style-type: none"> ● Excitation angle change 	<ul style="list-style-type: none"> ● Target rpm change
Air conditioner switch			<ul style="list-style-type: none"> ● Target rpm change after engine warms up
Neutral switch		<ul style="list-style-type: none"> ● Ignition timing change (at idle) 	<ul style="list-style-type: none"> ● Idle control start in neutral position
Power steering switch			<ul style="list-style-type: none"> ● Prevention of engine speed reduction when power steering is turned.

1-3 DIAGNOSIS CHART ITEM BY PROBLEM

- (1) Unable to start ... No initial combustion
- (2) Unable to start ... Initial combustion occurs but is incomplete.
- (3) Hard to start ... Hard to start when engine is cold.
- (4) Hard to start ... Hard to start after warm-up.
- (5) Hard to start ... Hard to start when engine is hot or cold.
- (6) Poor idling ... Fast idling inoperative
- (7) Poor idling ... Low idle rpm (after warm-up)
- (8) Poor idling ... High idle rpm (after warm-up)
- (9) Unstable idling ... Cold engine only
- (10) Unstable idling ... During warm-up
- (11) Poor driveability ... Engine breathing
- (12) Poor driveability ... Knocking
- (13) Poor driveability ... Lack of output, poor acceleration, poor response
- (14) Engine stalls when starting off
- (15) Engine stall during idling
- (16) Engine stall during driving
- (17) Engine stall when decelerating or immediately after stopping
- (18) Engine stall when electrical load or power steering load is applied

B3 ECCS (Electronically Concentrated Engine Control System)

1. Trouble Diagnosis (Cont'd)

Diagnostic chart by problem

(1) Unable to start ... No initial combustion

[Analysis]

Ignition spark is not generated or no fuel is injected.

- Check if fuel pump is rotating.
- If no ignition spark is generated and no injector operating noise is heard, check the control unit input (crank angle sensor signal) or control unit power supply.
- If injector is operating but no spark is generated, the control unit and crank angle sensor can be judged as normal. In this case, check the ignition output system (power transistor, ignition coil, etc.)
- If ignition spark is generated but injector is not operating, check the ignition output system (injector power supply, harness, etc.).

[Chart]

Fuel pump?

(See 5-1)

Operating?

Check fuel hose for tension in CONSULT active test mode.

Or

Check if pump operating noise is heard for five seconds after turning ignition switch ON. (If NOT, check fuel pump system.)

Injector?

(See 5-2)

Operating?

Check if injector operating noise is heard when cranking engine.

Or

Check using CONSULT data monitor mode if injection pulse is output when cranking engine.

(The injection pulse value monitored on CONSULT indicates the calculation results of input signals from the crank angle sensor and air flow meter. As a result, the injector may not be operating even if this value is correct.)

If not correct:

- Check control unit terminal voltage when cranking engine.
- Check injector power supply circuit
- Crank angle sensor input signal inspection

Ignition spark?

Is there a spark?

Check if tachometer needle moves during cranking.

Check using real-time diagnostic mode. (CONSULT data monitor)

Check using a timing light.

- Remove plug and visually check for spark.

If NOT O.K.:

- Check control unit output signal (ignition signal)
- Check control unit input signal (crank angle sensor)
- Check power transistor and ignition coil resistance value

B3 ECCS (Electronically Concentrated Engine Control System)

1. Trouble Diagnosis (Cont'd)

(2) Unable to start ... Initial combustion occurs but is incomplete

[Analysis]

Occurrence of initial combustion means that sparks are created. The following three cases are possible.

- ① Initial combustion only
 - Is fuel system (fuel pump, fuel injector) operating?
- ② Engine fires incompletely
 - Check if fuel injection quantity is too small or large.
 - Check if fuel pressure is normal.
 - Check if water temperature enrichment is provided.
 - Check if start-time enrichment is provided.
 - Check if ignition timing is normal.
- ③ Engine fires completely if accelerator pedal is moved up and down.
 - Check if AAC valve operation is normal.

[Chart]

Fuel pressure?

(See 3-3)

- Is pump operating? ————— Check fuel hose for tension in CONSULT active test mode.
Or
Check if fuel pump operating noise is heard for five seconds after ignition switch is turned ON.
Is fuel pump operating during cranking?
(If NOT O.K., check the fuel pump system.)

Injection quantity?

- Engine temperature enrichment provided? ——— Check water temperature of CONSULT data monitor mode.
Or
Disconnect engine temperature sensor connector and check for any change.
 - Check water temperature resistance value.
 - Check engine temperature sensor output voltage.
- Start-time enrichment provided? ——— Check "START" signal [ON/OFF] (CONSULT data monitor mode)

Idling control?

(See 5-4)

- Is idling rpm increased? ————— Check AAC valve operation (CONSULT active test).
Check if AAC valve is fully closed (CONSULT data monitor).
Check AAC valve circuit for disconnection or loose connectors.

Ignition system?

- Is ignition timing normal? ————— Try to advance or retard timing angle.
- Is ignition correct? ————— Check spark plugs for fouling.
Check for ignition misfiring
(Check using a timing light or CONSULT real-time diagnostic mode.)

B3 ECCS (Electronically Concentrated Engine Control System)

1. Trouble Diagnosis (Cont'd)

(3) Hard start ... Hard to start when engine is cold.

[Analysis]

The systems relating to water temperature must be checked because this problem only occurs when the engine is cold.

- Fuel injection enrichment from engine temperature sensor signal is not functioning when temperature is low.
- Idling speed control is not functioning normally.
- Start-time enrichment is not functioning.
- Cranking speed is too low.

[Chart]

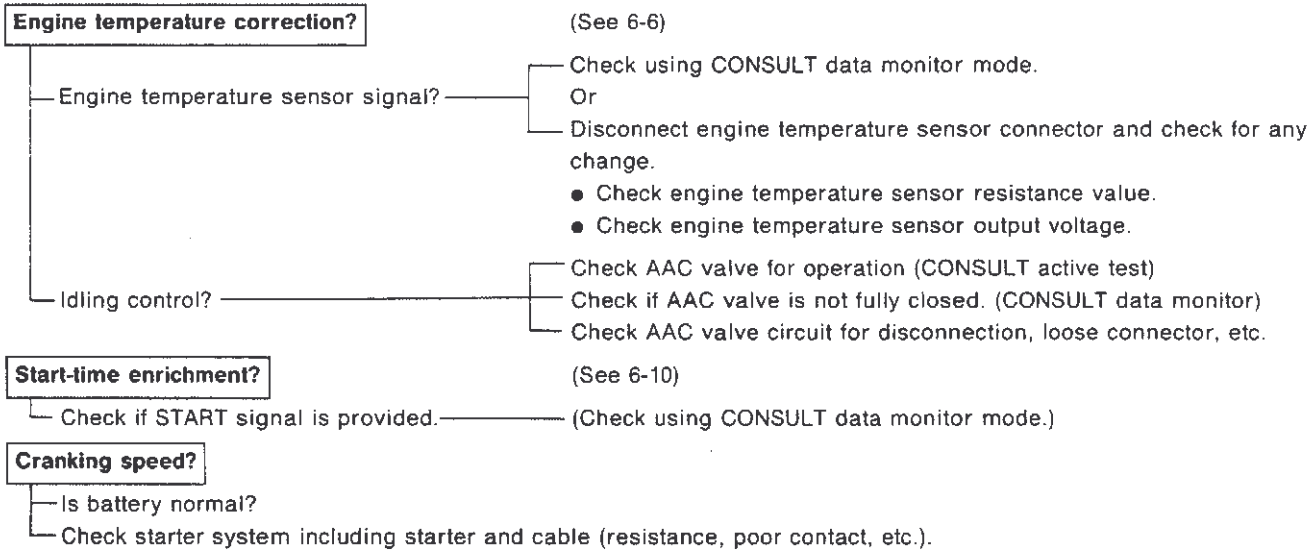

B3 ECCS (Electronically Concentrated Engine Control System)

1. Trouble Diagnosis (Cont'd)

(4) Hard start ... Hard to start after warm-up

[Analysis]

This problem may be related to the water temperature control.

- Check if engine temperature correction is inaccurate.
- Check if fuel pressure is correct or if air bubbles are generated in the fuel when the engine is hard to start, especially when water temperature is high.
- Check if engine cranking speed is low.

[Chart]

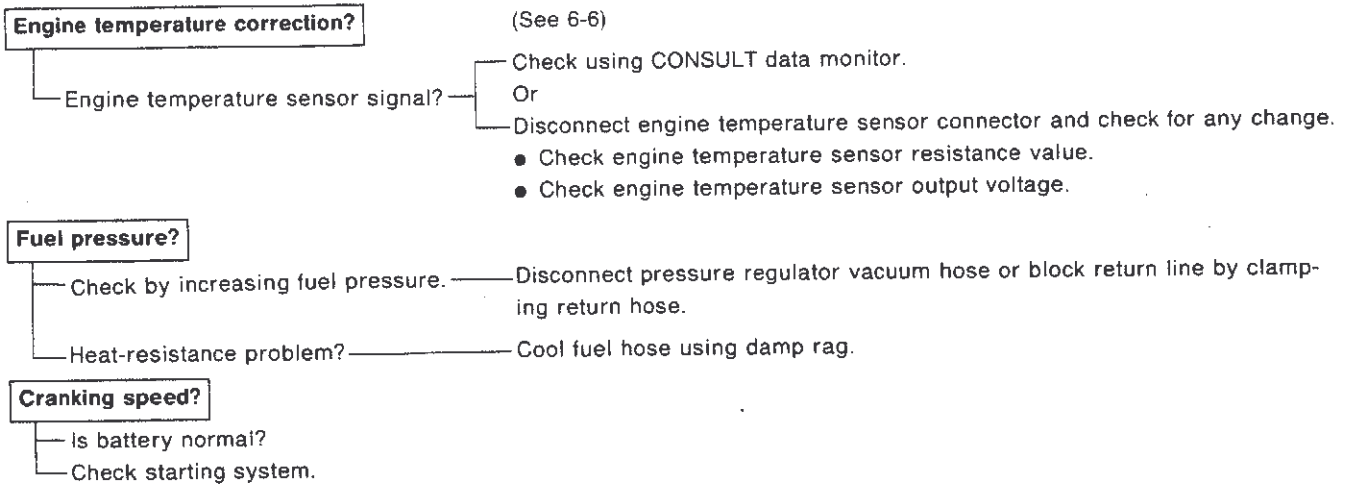

B3 ECCS (Electronically Concentrated Engine Control System)

1. Trouble Diagnosis (Cont'd)

(5) Hard start ... Hard to start regardless of engine temperature

[Analysis]

Spark arc is created but air-fuel ratio seems to be incorrect.

- Check fuel pressure.
- Check fuel injection quantity. (Is engine temperature correction accurate?)
- Check if idling speed is controlled.
- Check for misfiring and incorrect ignition timing.
- Check if cranking speed is too low.

[Chart]

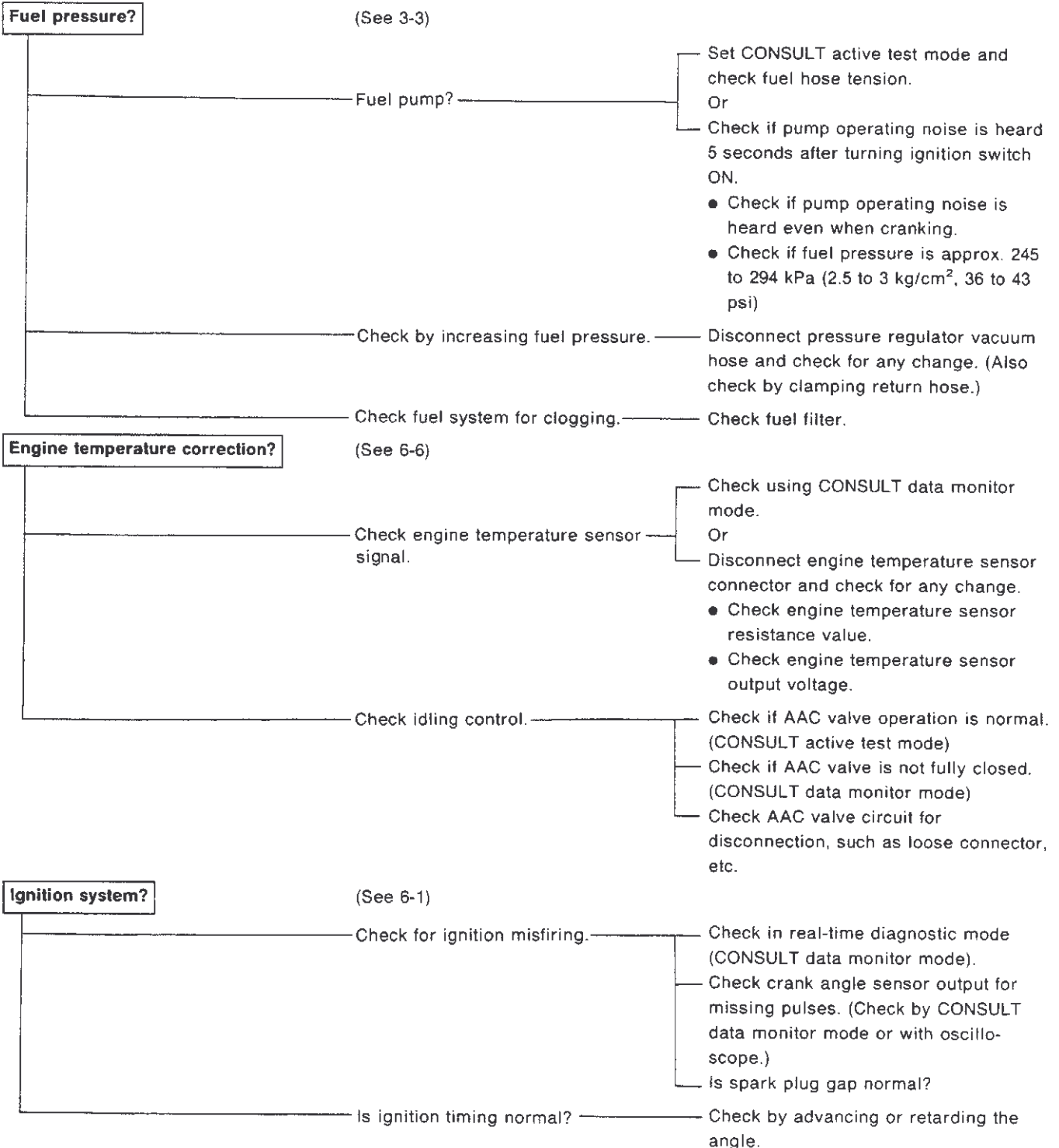

B3 ECCS (Electronically Concentrated Engine Control System)

1. Trouble Diagnosis (Cont'd)

Cranking Speed?

Is battery normal?

Check charged state.

Check starting system.

B3 ECCS (Electronically Concentrated Engine Control System)

1. Trouble Diagnosis (Cont'd)

(6) Poor idling ... Fast idle inoperative

[Analysis]

This problem may be due to abnormal control of AAC valve and air regulator because idling speed is controlled by these devices.

The air-fuel ratio and ignition timing also relate to this problem.

[Chart]

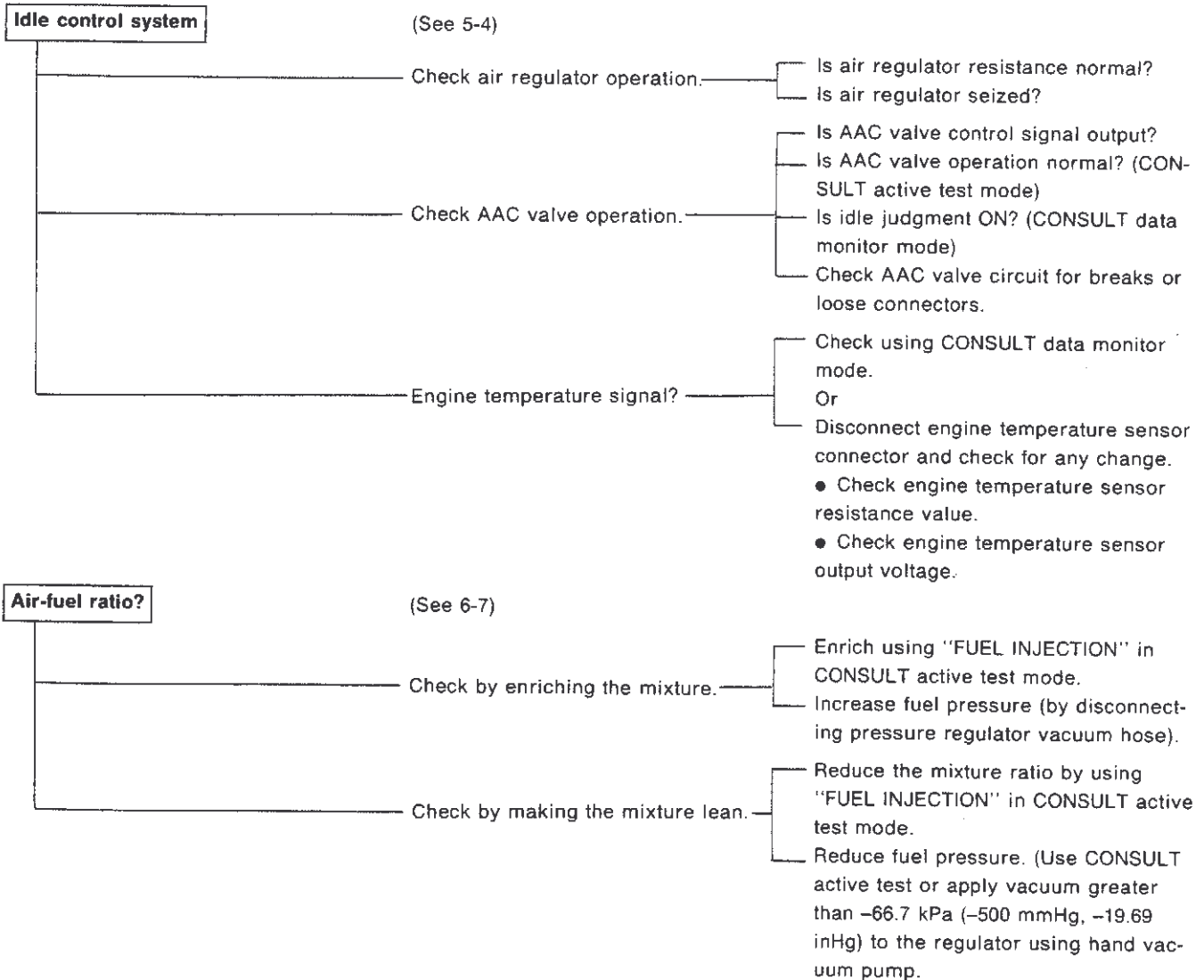

B3 ECCS (Electronically Concentrated Engine Control System)

1. Trouble Diagnosis (Cont'd)

(7) Poor idling ... Low idling rpm (after warm-up)

[Analysis]

Idling speed is controlled by the AAC valve. A low idling rpm means insufficient auxiliary air volume through AAC valve.

[Chart]

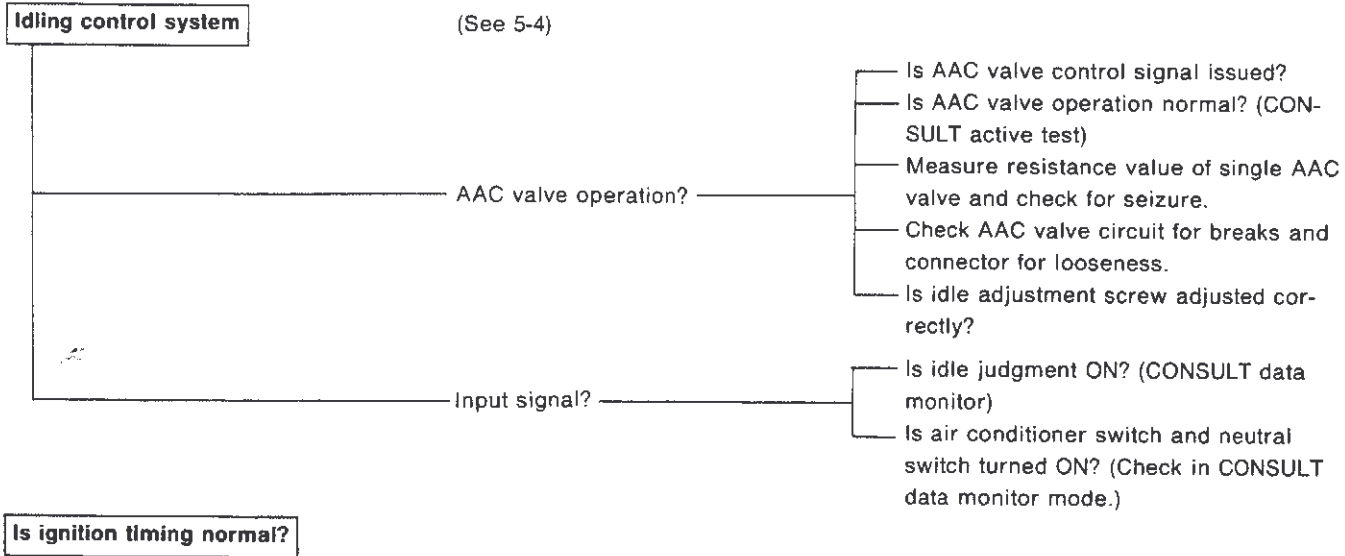

B3 ECCS (Electronically Concentrated Engine Control System)

1. Trouble Diagnosis (Cont'd)

(8) Poor idling ... High idle rpm (after warm-up)

[Analysis]

High idling can be caused by the following factors.

- Low engine temperature signal. (Actual engine temperature differs from monitored temperature.)
- Idle judgment (throttle sensor) is OFF.
- Air conditioner switch and power steering switch are ON continuously.
- AAC value is seized.
- Idle adjustment screw is not adjusted correctly. (Excessive throttle open position does not reduce engine rpm even if AAC valve is fully closed.)
- Air regulator is not energized.
- Air regulator is seized.
- Control unit adjustment knob is set at HIGH position.
- Throttle valve is open.
- Air is being sucked in.

[Chart]

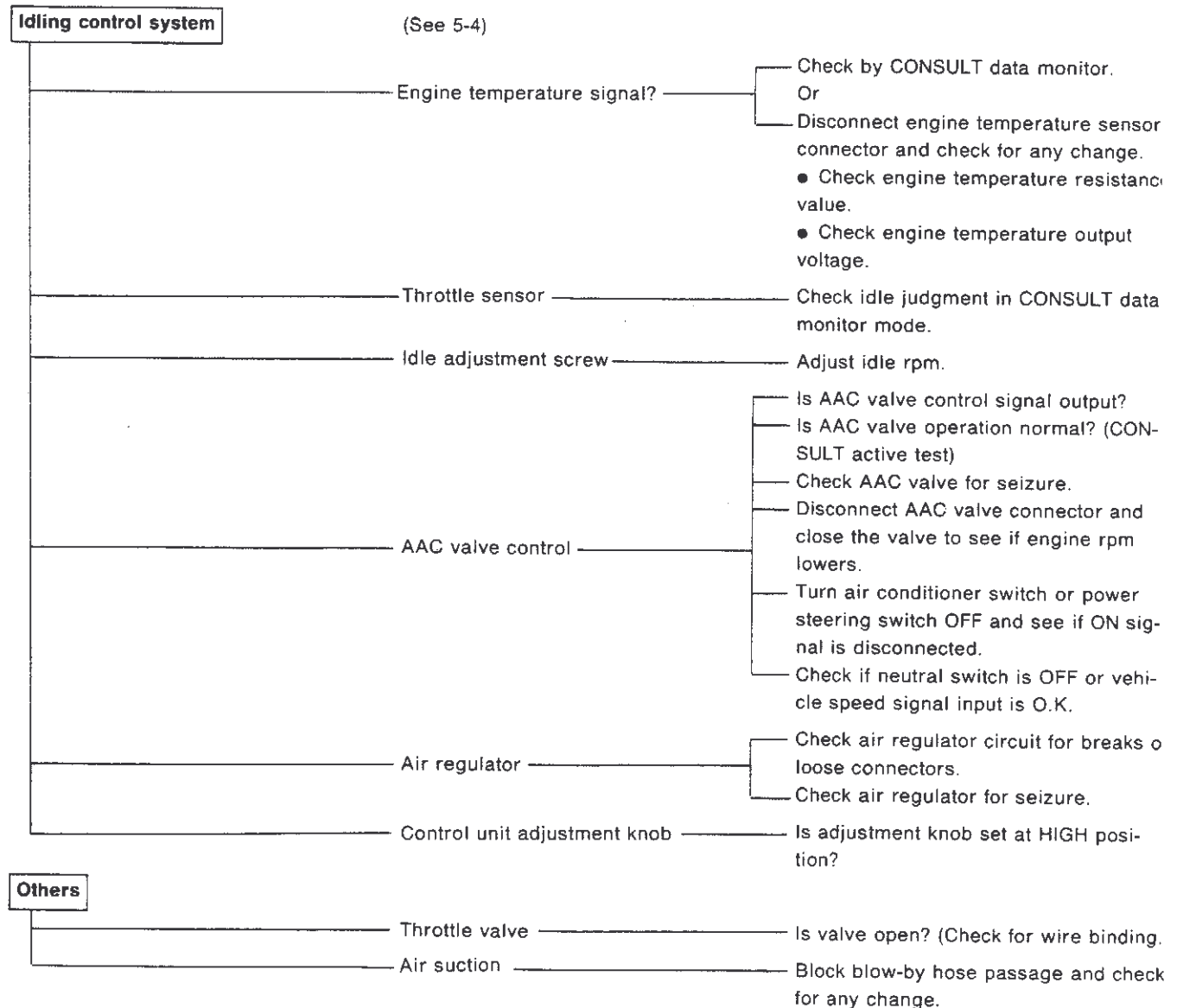

B3 ECCS (Electronically Concentrated Engine Control System)

1. Trouble Diagnosis (Cont'd)

(9) Unstable idling ... Cold engine only

[Analysis]

Since idling is unstable only when the engine is cold, cause of this problem can be narrowed down to the relationship between the engine temperature and idle control system. This problem also relates to the air-fuel ratio, ignition timing, misfiring, etc.

[Chart]

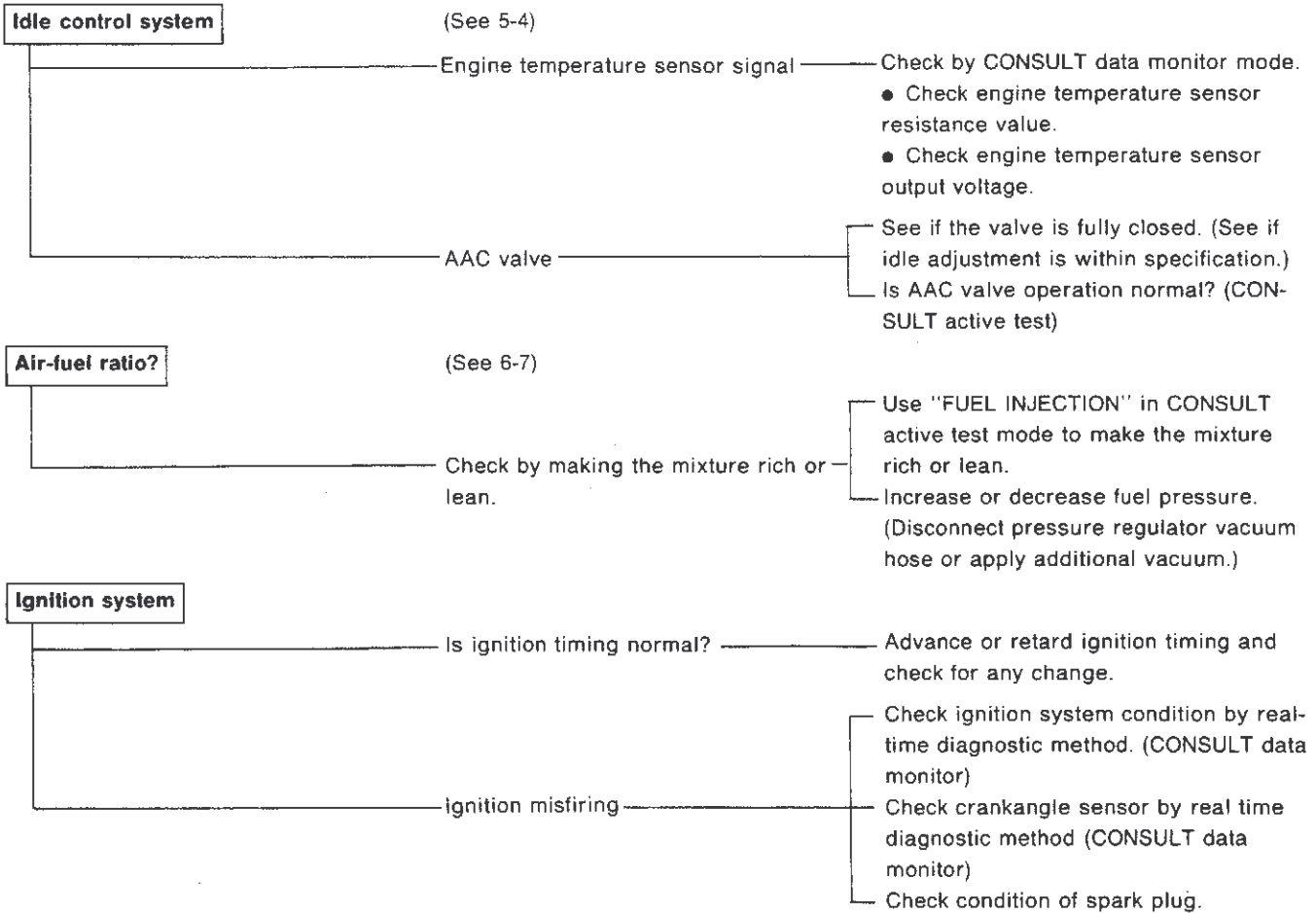

(10) Unstable idling ... After warm-up

[Analysis]

This problem relates to various factors including air-fuel ratio, ignition system and compression. It is necessary to determine factors beginning with items that are easy to check.

- Idle rpm control system ... AAC valve operation?
- Air-fuel ratio ... Fuel pressure?
 - Injection quantity? (Enriched?)
 - Air suction?
- Ignition system ... Ignition timing
 - Ignition misfiring (missing signal pulse)
- Engine main unit ... Poor compression

B3 ECCS (Electronically Concentrated Engine Control System)

1. Trouble Diagnosis (Cont'd)

[Chart]

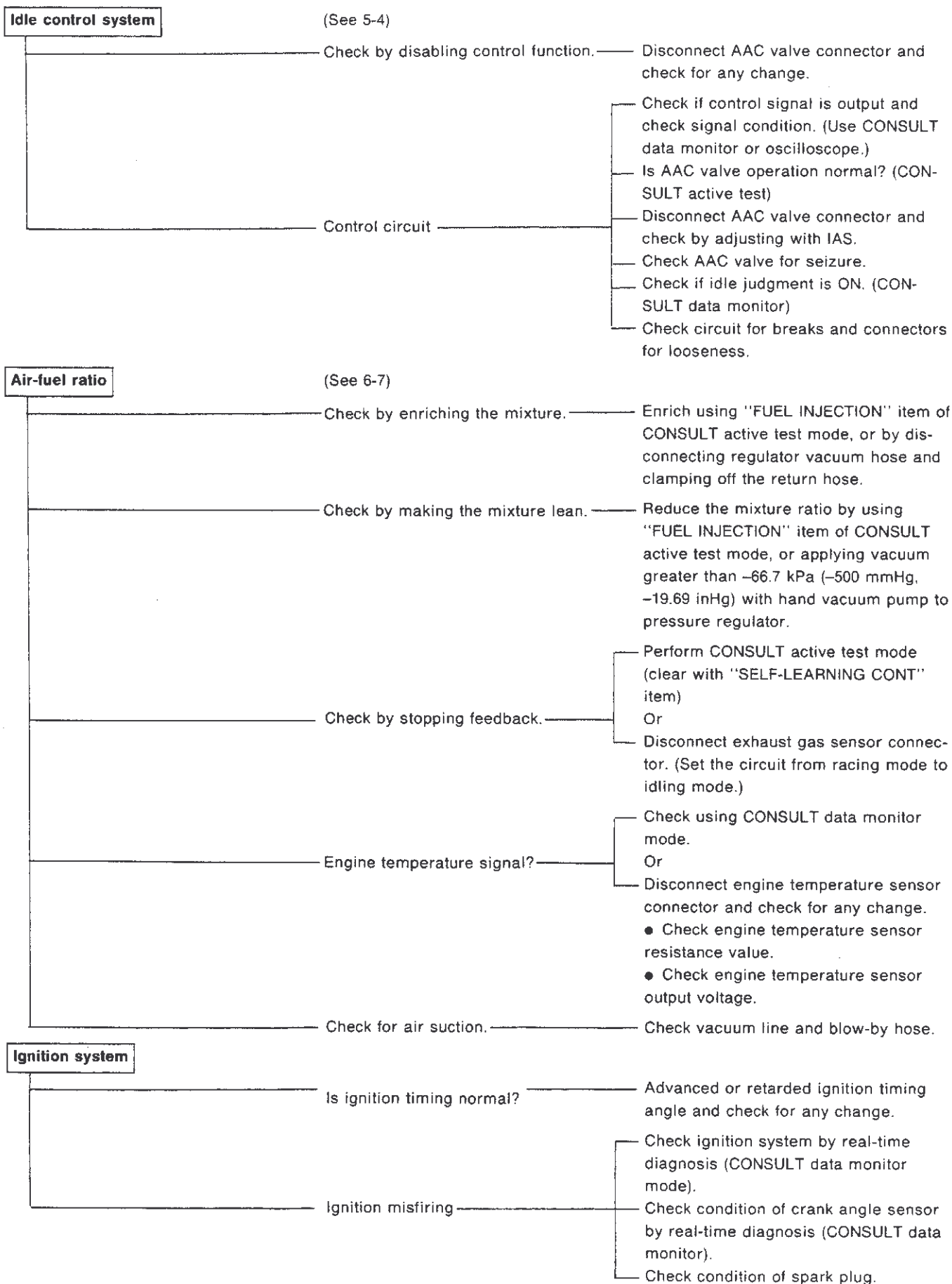

B3 ECCS (Electronically Concentrated Engine Control System)

1. Trouble Diagnosis (Cont'd)

Engine main body

Compression pressure? Measure compression pressure. (Check valve timing, valve seats, piston rings, etc.)

(11) Poor driveability ... Engine breathing

[Analysis]

Items to be checked vary if this problem occurs during acceleration or during cruising.

① During acceleration

- Engine breathing while depressing the accelerator may be caused by momentary misfiring, or momentary occurrence of lean mixture (no interrupt injection).
- Increased tension of harnesses or air duct due to inclination of engine during acceleration can also be a cause of poor contact.
- Clogging in fuel system is a cause for engine breathing because sufficient fuel pressure cannot be maintained during acceleration.

② During cruising

- Lean mixture and engine breathing caused by poor feedback of air-fuel ratio data.
- Misfiring of ignition system caused by leaks.
- Poor contact or malfunction of signal system, use of low quality gasoline.

[Chart]

① When accelerating

Air-fuel ratio	(See 6-7)
Stop feedback	Perform CONSULT active test mode (set to 0% by "FUEL INJECTION" item). Or Check by disconnecting exhaust gas sensor.
Enrich mixture	Perform CONSULT active test mode (increasing "FUEL INJECTION" item) or enrich mixture by disconnecting engine temperature sensor connector and inserting a 600Ω resistance after warming up the engine.
Idle judgment	Check idle judgment ON/OFF operation in CONSULT data monitor mode.
Throttle sensor	Check if output voltage varies with throttle opening.
Fuel pressure	Check if fuel pressure is maintained even while racing the engine.
Air leak	Check air duct for looseness.
Air flow meter output	Check output voltage (by CONSULT data monitor).

B3 ECCS (Electronically Concentrated Engine Control System)

1. Trouble Diagnosis (Cont'd)

Ignition system

Ignition misfiring

Check signal system (ignition signal, crank angle sensor signal, air flow meter signal) for instantaneous break by using real-time diagnosis (CONSULT data monitor) or oscilloscope.
Check spark plug gap.
Check if ignition coil power supply voltage is lowered.

Ignition timing

Check if fail-safe mode is not set due to a detonation sensor error. (Check by self-diagnosis.)

② When cruising

Air-fuel ratio

(See 6-7)

Feedback function

Check by CONSULT active test mode. (Set mixture ratio by fuel injection quantity correction to 0%.)

Or

Check by disconnecting exhaust gas sensor connector.

Set self-diagnosis mode 2 and see if exhaust gas temperature warning lamp (or control unit red lamp) is flashing (exhaust gas sensor monitor diagnosis) or check in CONSULT data monitor mode.

Set self-diagnosis mode 2 and check if exhaust gas temperature warning lamp (or control unit red lamp) is flashing more than 5 times in 10 seconds when engine is running at 2,000 rpm, or check by CONSULT data monitor.

Idle judgment

Check if throttle sensor is OFF when accelerator pedal is depressed. (CONSULT data monitor)

Ignition system

Ignition misfiring

Check for instantaneous break in signal system using real-time diagnosis. (Ignition signal, crank angle sensor signal, air flow meter signal) (Use CONSULT data monitor or oscilloscope.)

B3 ECCS (Electronically Concentrated Engine Control System)

1. Trouble Diagnosis (Cont'd)

(13) Poor driveability ... Lack of output, poor acceleration, poor response

[Analysis]

Lack of power, poor acceleration and poor response are generally caused by insufficient mixture quantity (lack of fuel, lack of air) or incorrect air-fuel mixture ratio.

In the injection system, these problems are caused by lack of ignition energy or incorrect ignition timing.

Lack of compression pressure and excessive friction due to seizure in engine main body are also causes of these conditions.

[Chart]

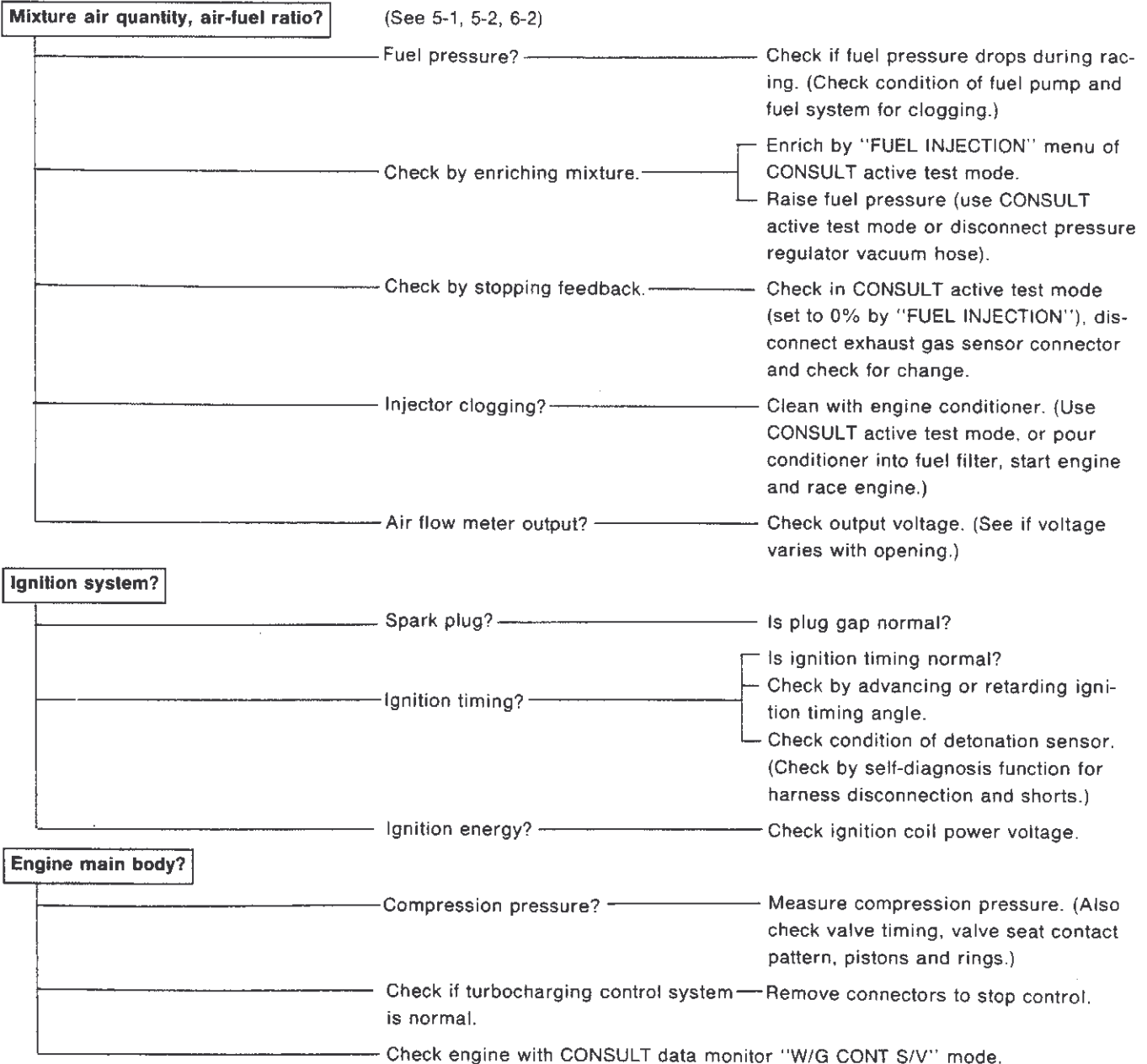

B3 ECCS (Electronically Concentrated Engine Control System)

1. Trouble Diagnosis (Cont'd)

(14) Engine stalls when starting

[Analysis]

Misfiring while depressing accelerator pedal or insufficient torque causes engine to stall when starting off.

- Misfiring
 - Too lean or too rich air-fuel mixture ratio
 - Large error in ignition timing
 - Weak spark
- Insufficient torque
 - Lean or rich mixture
 - Insufficient intake air quantity
 - Insufficient compression pressure

[Chart]

Self-diagnosis

Check if occurrence of error is stored by self-diagnosis function.

Air-fuel ratio?

(See 6-4, 6-6, 6-7)

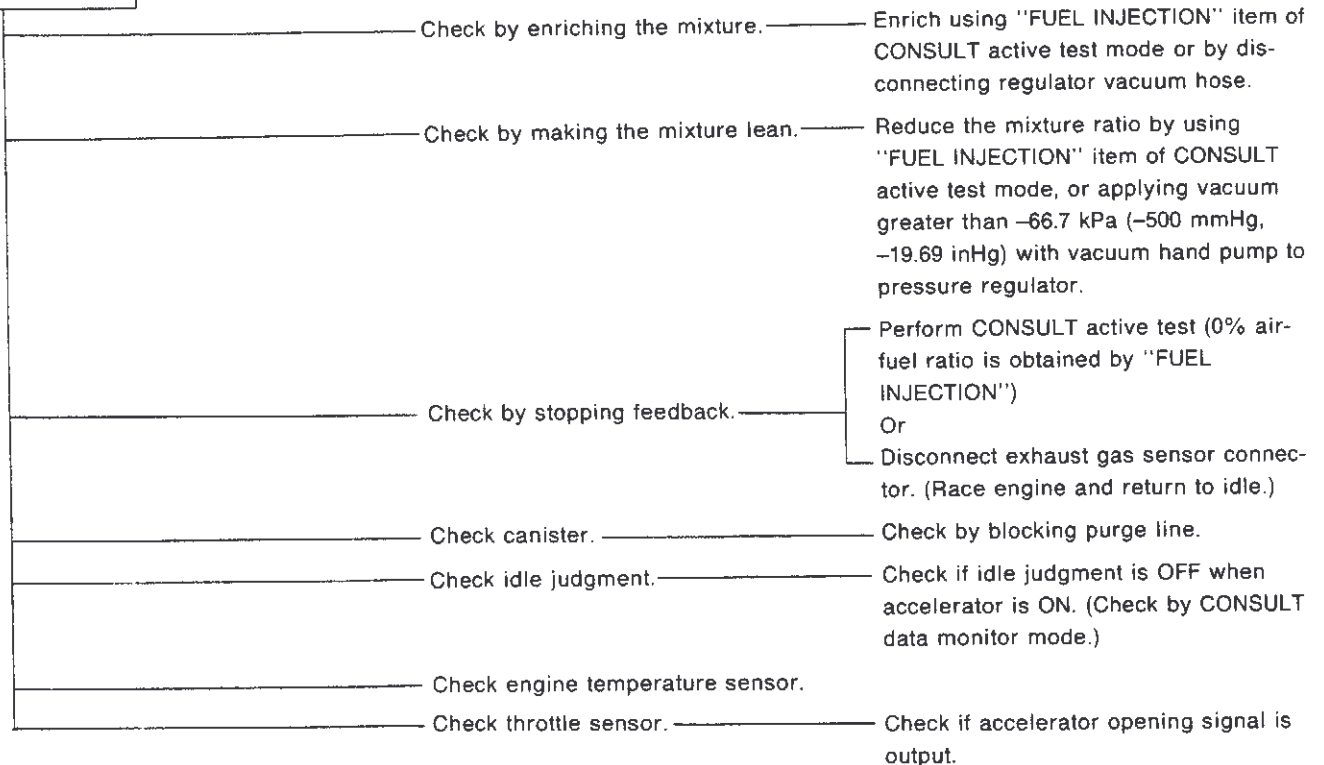

Ignition?

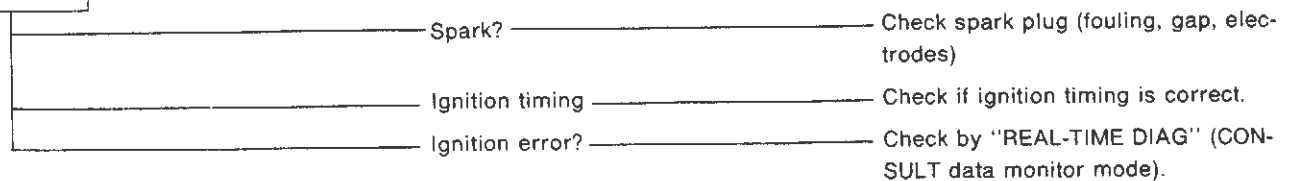

Intake air quantity?

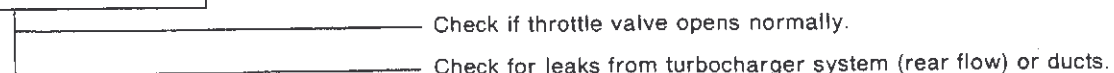

B3 ECCS (Electronically Concentrated Engine Control System)

1. Trouble Diagnosis (Cont'd)

Compression pressure?

Measure compression

Check valve timing for error, valves for incorrect contact pattern, pistons and rings for damage.

(15) Engine stall during idling

[Analysis]

Engine stall during idling may be caused by one of the following conditions. (Check idling speed, and then check for misfiring.)

- Improper idling speed
- Improper AAC valve control (Check for delayed response.)
- Excessively lean or rich mixture ratio
- Ignition error
- Poor contact of connector, etc.
- Relation to electrical load ON-OFF

[Chart]

Self-diagnosis

Check if any abnormal data is stored in self-diagnosis.

Idling control? (See 5-4)

Check for proper control.

- Is idling speed normal or adjusted?
- Is AAC valve fully closed? (Check for loose connector.)
- Close AAC valve and check for any change.
- Is AAC valve control signal issued? (Race engine and check voltage.)
- Is AAC valve operation normal? (CONSULT active test)
- Disconnect AAC valve connector, and check by adjusting with IAS.
- See if idle judgment is ON.

B3 ECCS (Electronically Concentrated Engine Control System)

1. Trouble Diagnosis (Cont'd)

Air-fuel ratio? (See 6-7)

- Is air-fuel ratio normal? ————— Select self-diagnosis mode 2 and check if exhaust gas temperature warning lamp (or red lamp on control unit) is flashing more than 5 times in 10 seconds when engine is running at 2,000 rpm, or check by CONSULT data monitor.
- Check by enriching the mixture. ————— Enrich using "FUEL INJECTION" item of CONSULT active test mode, by disconnecting pressure regulator vacuum hose or closing off the return hose.
- Check by making the mixture lean. ————— Reduce the mixture ratio by using "FUEL INJECTION" item of CONSULT active test mode, or applying vacuum greater than -66.7 kPa (-500 mmHg, -19.69 inHg) with hand pump to pressure regulator.
- Check by stopping feedback. ————— Perform CONSULT active test (0% air-fuel ratio is obtained by "FUEL INJECTION")
Or
Disconnect exhaust gas sensor connector. (Set circuit from racing mode one time and return to idling mode.)
- Check fuel pump operation. ————— Check for pump stop.
- Check fuel system for clogging. ————— Race engine and check fuel pressure for drop.

Others

- Check for poor contact. ————— Using real-time diagnosis mode, check ignition signal, crank angle sensor signal and air flow meter signal for instantaneous break and missing pulses. (Use CONSULT data mode or oscilloscope.)
- Check spark plugs. ————— Check for fouling and plug gap.

B3 ECCS (Electronically Concentrated Engine Control System)

1. Trouble Diagnosis (Cont'd)

(16) Engine stalls during driving

[Analysis]

Engine stall during cruising may be caused by misfiring. If engine stalls during acceleration, it may be caused by misfiring or insufficient torque.

- Too rich or lean air fuel mixture
- Ignition error
- Incorrect ignition timing
- Insufficient intake air quantity
- Insufficient compression pressure
- Misfiring, fuel pump stop, etc. caused by poor electrical contact

[Chart]

Self-diagnosis

Check the stored data by self-diagnosis for any abnormality.

① When cruising

Air-fuel ratio? (See 6-7)

Idle judgment?

Check if idle judgment goes OFF when accelerator pedal is pressed. (Check in CONSULT data monitor mode.)

Check for normal feedback.

Race engine at 2,000 rpm in self-diagnosis mode and check if exhaust gas temperature warning lamp (or red lamp on control unit) is flashing more than 5 times in 10 seconds or check by CONSULT data monitor.

Stop feedback and check for any change.

Perform CONSULT active test.
Or
Check by disconnecting exhaust gas sensor connector.

Intake air quantity signal

Check for poor contact using CONSULT data monitor ("REAL-TIME DIAG") mode.

Ignition?

Ignition timing?

Is ignition timing normal?

Ignition misfiring

Check ignition signal and crank angle sensor signal for missing pulses in CONSULT data monitor ("REAL-TIME DIAG") mode.

B3 ECCS (Electronically Concentrated Engine Control System)

1. Trouble Diagnosis (Cont'd)

② During acceleration

Air-fuel ratio?

Idle judgment? ————— Check if idle judgment goes OFF-ON when accelerator pedal is pressed and released. (Check in CONSULT data monitor mode.)

Throttle sensor? ————— Check if voltage output varies with throttle opening. (Check in CONSULT data monitor mode.)

Check for normal feedback. ————— Race engine at 2,000 rpm in self-diagnosis mode and check if exhaust gas temperature warning lamp (or red lamp on control unit) is flashing more than 5 times in 10 seconds or check by CONSULT data monitor.

Stop feedback and check for any change. ————— Perform CONSULT active test. ("FUEL INJECTION" set to 0%)
Or
Check by disconnecting exhaust gas sensor connector.

Intake air quantity signal ————— Check for poor contact using CONSULT data monitor ("REAL-TIME DIAG") mode.
Check for air flow or leaking after turbocharger operation.

Misfiring?

Ignition timing? ————— Is ignition timing normal?

Ignition misfiring? ————— Check ignition signal and crank angle sensor signal for missing pulses in CONSULT data monitor ("REAL-TIME DIAG") mode.

Compression pressure?

Measure compression pressure.

B3 ECCS (Electronically Concentrated Engine Control System)

1. Trouble Diagnosis (Cont'd)

(17) Engine stalls when decelerating or immediately after stopping.

[Analysis]

Reduced engine rpm when releasing accelerator can lead to engine stall. Another cause is misfiring.

- Incorrect adjustment of idling control
- Incorrect air-fuel ratio
- Ignition error

[Chart]

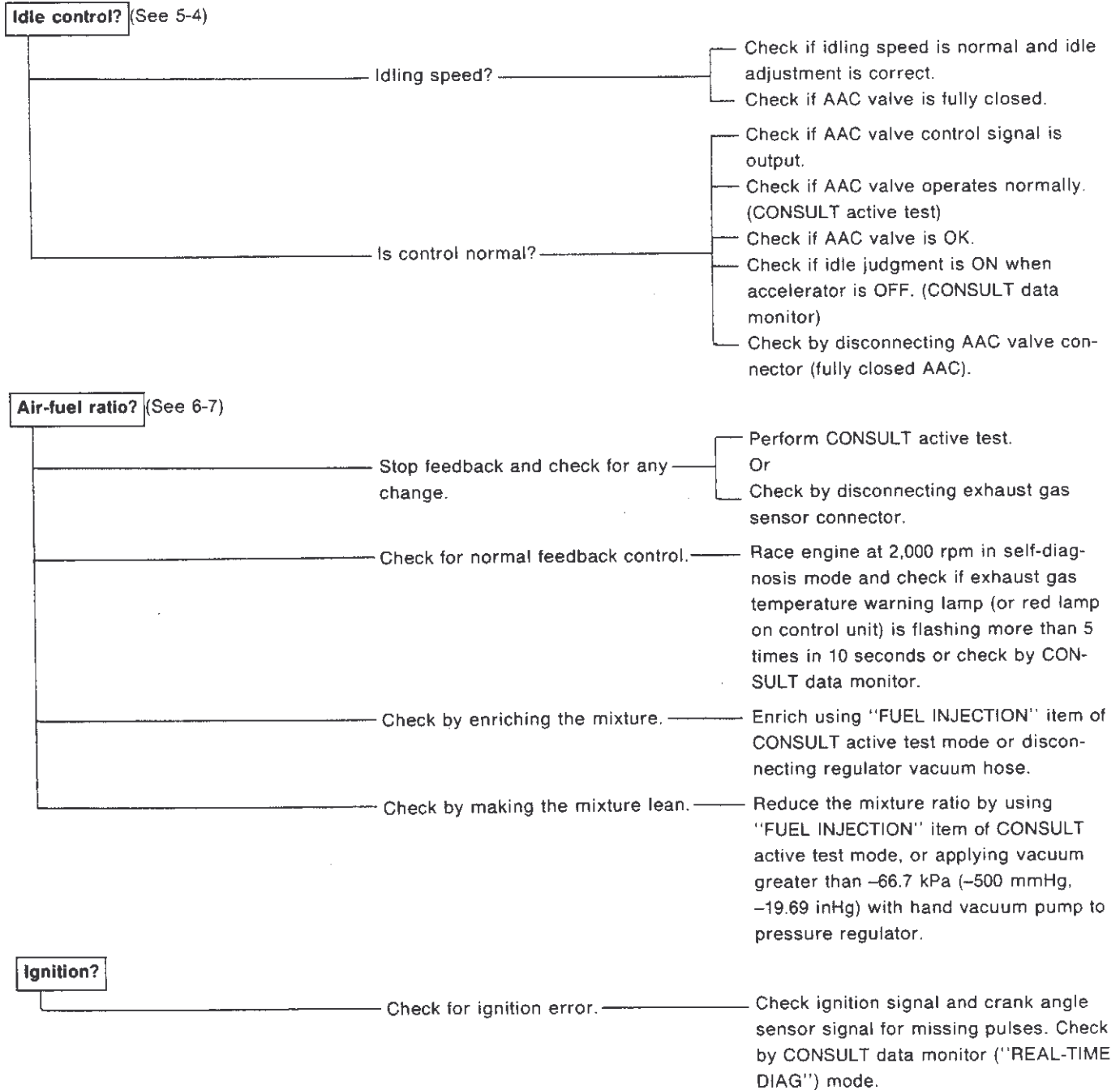

B3 ECCS (Electronically Concentrated Engine Control System)

1. Trouble Diagnosis (Cont'd)

(18) Engine stalls when electrical load or power steering load is applied

[Analysis]

Check if idling is increased when load switch is turned ON (AAC valve correction quantity increases when load is applied).

- Check if ON signal is input from each switch.
- Check if AAC valve is operating.

[Chart]

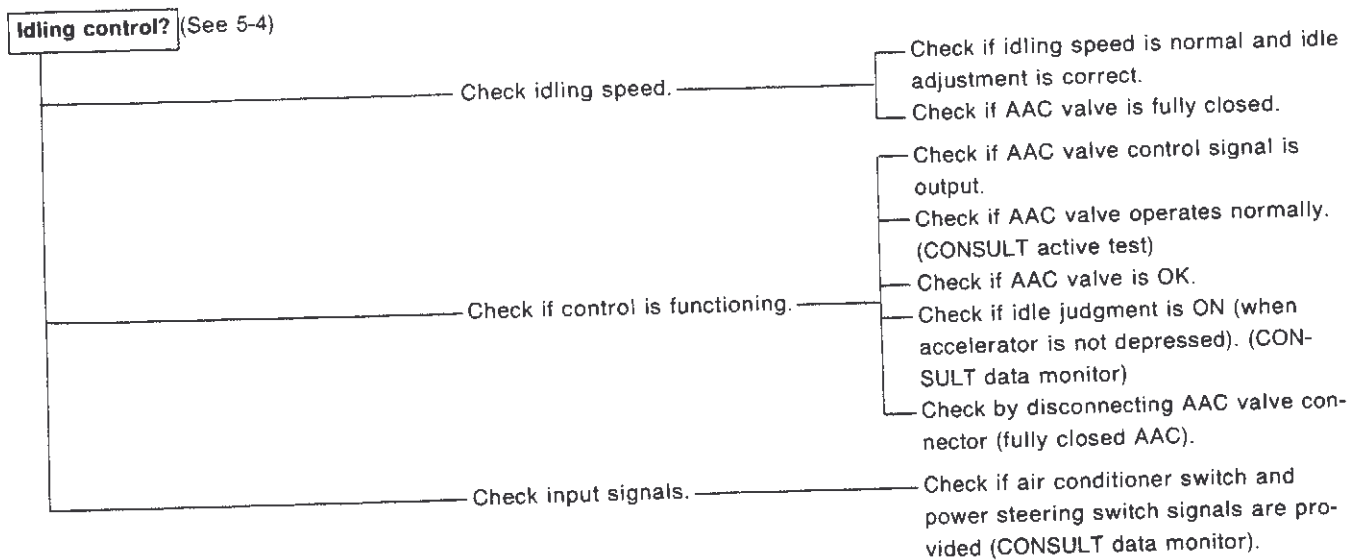

2. Diagnostic System

2-1 GENERAL

The diagnostic system performance has been greatly improved concerning warning indication to drivers, operation of the self-diagnostic system, and application of the newly developed electrical system diagnostic tester CONSULT.

(1) Enhanced fault alarm items

If an error occurs in the ECCS system during driving, the exhaust gas temperature warning lamp flashes in the combination meter. At the same time, the backup function is activated to ensure the safety of the occupants and vehicle.

(2) Simplified troubleshooting

The following features have been incorporated for ease of inspection and problem diagnosis of ECCS system.

① Improvement of self-diagnostic function

The diagnostic modes have been rearranged and the mode shift and display systems have been simplified.

New system			Current system		
Diagnostic mode	Mode selection	Display	Diagnostic mode	Mode selection	Display
1	Fault alarm (Same as the former backup display mode)	Indicated by exhaust gas temperature warning lamp (also linked with the red lamp on control unit)	1	Backup display	By adjustment knob on control unit. Indicated by red or green lamps on control unit.
	Exhaust gas sensor monitor (Same as the former air-fuel ratio feedback display)		2	Air-fuel ratio feedback display	
Self-diagnosis	3		Ordinary self-diagnosis		
(The former ON/OFF switch diagnosis and real-time diagnosis are included in the operations performed by CONSULT as explained in item ② on the next page.)	4		ON/OFF switch diagnosis		
	5		Real-time diagnosis		



B3 ECCS (Electronically Concentrated Engine Control System)

2. Diagnostic System (Cont'd)

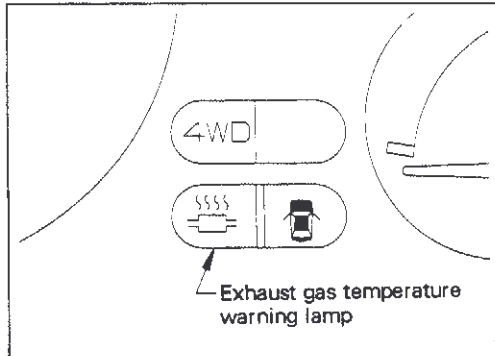
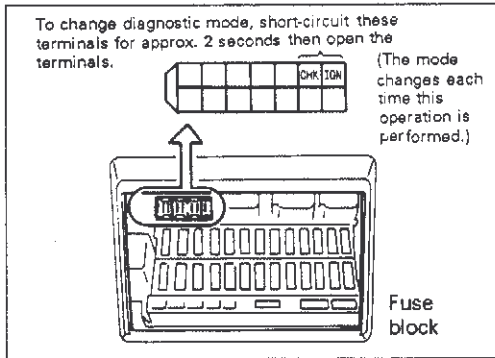

② Adoption of electronic system diagnostic tester for problem diagnosis.

The diagnostic functions have been modified to enable use of the newly developed electrical system diagnostic tester CONSULT to simplify complex diagnosis procedures.

CONSULT is a compact and lightweight hand-held type test device especially designed for automotive service operations, and can be used by simply connecting it to the diagnostic connector installed on the vehicle. This tester permits data display, recording and printing.

B3 ECCS (Electronically Concentrated Engine Control System)

2. Diagnostic System (Cont'd)

The CONSULT system has the following functions.

Mode	Description		Mode selection	Display	
Diagnostic mode	SELF-DIAGNOSTIC RESULTS	Self-diagnosis	Diagnostic modes can be selected easily by the touch-sensitive keys of CONSULT.	Displayed data can be read easily on the CONSULT screen.	
	DATA MONITOR	<ul style="list-style-type: none"> ● Used to identify major cause of fault, according to results of self-diagnosis. ● Permits monitoring (observation and recording) and printing of input and output data of the control unit. ● Permits data to be recorded in case of engine damage or engine stall. ● The former diagnostic modes listed below are included in this monitor item. 			
		<ul style="list-style-type: none"> ● Exhaust gas sensor monitor 			Displays exhaust gas sensor output voltage and if mixture is lean or rich.
		<ul style="list-style-type: none"> ● Switch ON/OFF 			Same as former function.
		<ul style="list-style-type: none"> ● Real-time diagnosis 			Same as the former function
ACTIVE TEST	<ul style="list-style-type: none"> ● Used to examine major causes of problems according to self-diagnosis results and data monitor. ● Used to check actuator operation by giving driving signal to the actuator. 				
Supplemental	WORK SUPPORT	<ul style="list-style-type: none"> ● Used to reduce additional operation when checking idling, etc. (Example: When adjusting AAC valve, feedback control can be fixed by using this mode.) 			

B3 ECCS (Electronically Concentrated Engine Control System)

2. Diagnostic System (Cont'd)

ECCS control unit input/output signals and applicable modes

Signal name		Mode	Self-diagnosis	Data monitor	Active test	Work support
Input	Crank angle sensor		○	○		
	Air flow meter		○	○		
	Engine temperature sensor		○	○	○	
	Exhaust gas sensor			○		
	Vehicle speed sensor			○		
	Battery voltage			○		
	Throttle sensor		○	○		○
	Idle position (throttle sensor)			○		
	Intake temperature sensor		○	○		
	Detonation sensor		○			
	Ignition switch (Start signal)			○		
	Air conditioner, neutral, power steering oil pressure switch			○		
	Output	Injectors			○	○
Power transistor (ignition signal)			○	○ (Ignition timing)	○ (Ignition timing)	
A.A.C. valve				○	○	○
Air conditioner relay				○		
Fuel pump relay				○	○	
Wastegate valve control solenoid valve				○		

B3 ECCS (Electronically Concentrated Engine Control System)

2. Diagnostic System (Cont'd)

2-2 SELF-DIAGNOSIS

Self-diagnosis can be performed by indications from the exhaust gas temperature warning lamp in the combination meter and the red lamp on the ECCS control unit, or by displaying data on the CONSULT screen.

(1) Exhaust gas temperature warning lamp indication

Two diagnostic modes are available. In each mode, diagnosis is performed by operating the diagnostic connector terminal installed on the vehicle. (Diagnosis can also be performed using the adjustment knob on the control unit.) The diagnosis results are displayed by the exhaust gas temperature warning lamp in the combination meter and the red warning lamp on the control unit.

Basic operation and indication

Mode \ Item		Operation	Indication (Flashing of exhaust gas temperature warning lamp and red warning lamp of control unit.)
Mode 1	Fault alarm	Ignition switch ON Engine rotation	Alarm: Faulty system is indicated by warning lamp flashing pattern (backup function). Normal: Warning lamp remains OFF.
Mode 2	Self-diagnosis	Ignition switch ON ↓ Diagnosis mode shift ↓ Engine stop (with ignition switch remaining ON)	Fault: Faulty system is indicated by flashing code. Normal: Flashing code "55" is displayed.
	Exhaust gas sensor monitor	Self-diagnosis status described above ↓ Engine rotation	Lamp ON means "lean" mixture; OFF means "rich" mixture.

① Fault alarm mode (Mode 1)

Step	Operation	Indication			
1	Turn ignition switch ON. Mode 1 is normally set by this operation. [Pay attention to the following case that may occur: If the ignition switch is turned OFF in the self-diagnosis mode and then turned ON in a few seconds, the self-diagnosis mode will be executed. In this case, the self-diagnosis mode must be selected. (See item ②.)]	Indicated by flashing exhaust gas temperature warning lamp in combination meter and red lamp of control unit. (These lamps are linked together.)			
			Engine rotation	Indication	Condition
		Alarm	Stop	ON (lamp check)	—
			Rotating	ON OFF	
		Normal	OFF	ON (lamp check)	—
Rotating	OFF		—		
2	Run engine.				

B3 ECCS (Electronically Concentrated Engine Control System)

2. Diagnostic System (Cont'd)

② Self-diagnostic mode (Mode 2)

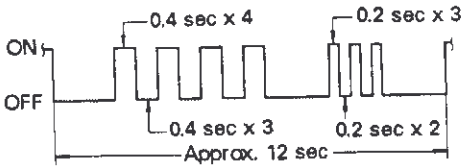
Step	Operation	Indication
1	<p>Turn ignition switch ON. Select the diagnostic mode by the method indicated below because the fault alarm mode is normally set after turning the ignition switch ON. Use a lead to short-circuit the CHK and IGN terminals connected on the diagnosis connector located on the vehicle (near the fuse block) for approx. 2 seconds, then separate the terminals. (Diagnosis connector)</p> <div style="text-align: center;">  </div> <p>(The fault alarm mode and self-diagnosis mode alternate each time the operation described above is performed.)</p>	<p>By flashing of the exhaust gas temperature warning lamp in combination meter and red lamp in control unit is used. (Operation of these two lamps is linked together.)</p> <p>Example: Indication of code number "43".</p> <div style="text-align: center;">  </div>
2	<p>Shut off engine (with the ignition switch remaining in ON position.) (If the engine is operated in this condition, the exhaust gas sensor monitor in the next mode is activated.)</p>	

(Reference) Names of diagnostic connector terminals
 CHK: Diagnosis start (check)
 IGN: Ignition power supply
 ⊖: GND
 RX: Control unit data reception
 TX: Control unit data transmission
 CLK: Transmission synchronization signal (clock)

Code No.	Diagnosis item	Error (code number) state
11	Crank angle sensor signal system	<ul style="list-style-type: none"> ● 1° signal or 120° signal is not input for a certain period of time after starting engine. ● Incorrect signal waveform (abnormal correlation between 1° signal and 120° signal)
12	Air flow meter signal system	<ul style="list-style-type: none"> ● Hot wire disconnection ● Disconnection or short-circuit in air flow meter power supply line, ground line or signal system. ● Signal output is below 0.5 volts for a certain period during engine operation. ● Signal output is higher than 2 volts for a certain period of time with engine stalled, or when ignition switch is set to ON from OFF.
13	Engine temperature sensor signal system	<ul style="list-style-type: none"> ● Break or short-circuit in engine temperature sensor signal system
21	Ignition signal system	<ul style="list-style-type: none"> ● Ignition signal is not generated continuously even though crank angle sensor signal is entered. (Disconnection between power transistor and control unit)
34	Detonation sensor signal system	<ul style="list-style-type: none"> ● Disconnection or short-circuit in detonation sensor signal system
41	Intake temperature sensor signal system	<ul style="list-style-type: none"> ● Disconnection or short-circuit in intake temperature sensor signal system
43	Throttle sensor signal system	<ul style="list-style-type: none"> ● Disconnection or short-circuit in throttle sensor signal system (When engine is running, short-circuit occurs when voltage is 0.2V maximum except for N range. Disconnection occurs when voltage is 5V minimum.)
55	No error	<ul style="list-style-type: none"> ● No abnormality was detected in any of the above signal systems.

B3 ECCS (Electronically Concentrated Engine Control System)

2. Diagnostic System (Cont'd)

How to erase memory

- (a) Stop engine in mode 2 and short-circuit terminals "CHK" and "IGN" of the diagnostic connector for approx. 2 seconds, then disconnect. This will erase the memory on all diagnosis items. (The memory is also erased when the self-diagnosis mode is switched to the fault alarm mode.) Refer to the diagram indicated in table above.
- (b) When method (a) is not used: The memory is erased automatically if the ignition switch "START" operation is performed successfully 50 times.
(The memory is automatically erased every 50 "START" operations of the ignition switch.)
- ③ Exhaust gas sensor monitor mode (mode 2)

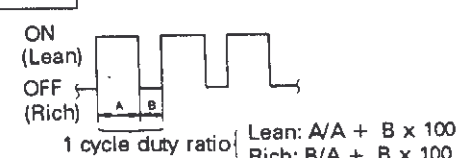
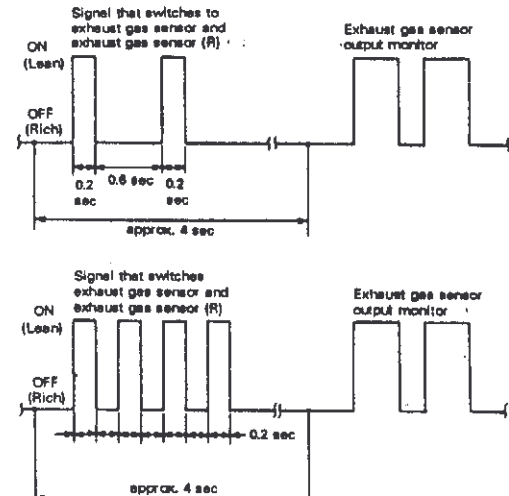
Step	Operation	Indication
1	<p>Set ignition switch to "ON".</p> <p>Make sure self-diagnosis mode is set. If problem alarm mode is set, connect diagnostic connector "CHK" and "IGN" terminals for approx. 2 seconds then disconnect the terminals. (See item ② above.)</p>	<p>Indication is made by the warning lamp (exhaust gas temperature warning lamp) on the instrument panel and the red lamp on the control unit. (These two lamps are linked together.)</p> <p>① During air-fuel ratio feedback control: When exhaust gas sensor output is "RICH": Lamps are OFF When exhaust gas sensor output is "LEAN": Lamps are ON (Reference) The lamp ON and OFF indication is the same as that of the air-fuel ratio feedback correction coefficient indicated by the red lamp in the former control unit.</p> <p>② When air-fuel ratio feedback control is clamped: The status immediately before clamping is maintained.</p> <p>③ When air-fuel ratio feedback control is faulty: OFF</p> <p>Display example</p> 
2	<p>Start engine.</p> <p>Note: Mode cannot be changed while engine is operating.</p> <p>After engine warms up adequately, increase engine speed until exhaust gas temperature warning lamp (approx. 2,000 rpm or until red lamp in control unit starts to flash) and exhaust gas sensor output monitor (R) mode is set.</p> <p>Caution: Check by pressing the accelerator pedal slightly because the air-fuel ratio feedback control is clamped during idling.</p> <p>Check that exhaust gas temperature warning lamp (or red lamp in control unit) flashes in this condition.</p> <p>Connect terminals "CHK" and "IGN" of the diagnostic connector for approx. 2 seconds, then disconnect. After the exhaust gas temperature warning lamp (or red lamp in control unit) flashes 2 times, the exhaust gas sensor output monitor mode is switched.</p>	<p>The status of the air-fuel ratio is indicated by the duty ratio in one cycle.</p> 

B3 ECCS (Electronically Concentrated Engine Control System)

2. Diagnostic System (Cont'd)

(2) CONSULT display screen

- Connect CONSULT to the diagnostic connector on the vehicle (lower side of fuse block) on the vehicle. Data is displayed on the CONSULT screen as the touch-sensitive keys of CONSULT are operated. The exhaust gas sensor monitoring, switch ON/OFF operation and real-time diagnosis are performed using the data monitor mode (see item 2-4).

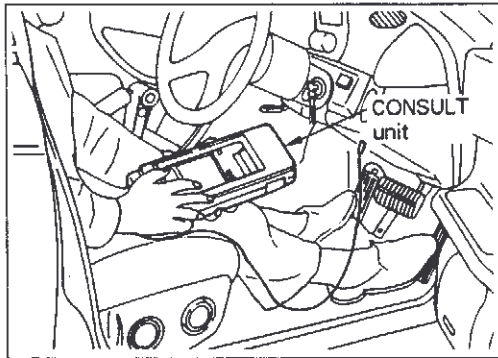
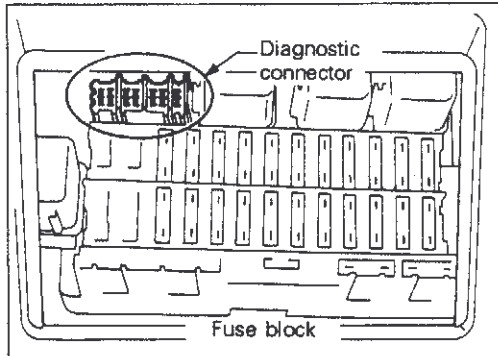

① "SELF-DIAGNOSTIC RESULTS" mode

The diagnosis items are the same as those listed in item (1) ②. Faulty system name is indicated.

Step	Operation	Display
1	Connect CONSULT to diagnostic connector of vehicle.	<div style="border: 1px solid black; padding: 5px; width: fit-content;"> <p style="text-align: center;">■ SELF-DIAG RESULTS ■</p> <p>FAILURE DETECTED TIME</p> <p>ENGINE TEMP SENSOR 0</p> </div> <p style="font-size: small; margin-top: 10px;">← The number of times the vehicle has been driven after detecting the last problem is displayed here. If the same problem is still present, "0" is displayed.</p>
2	Set ignition switch to "ON". (Shut off engine.)	
3	Check with "SELF-DIAGNOSTIC RESULTS".	
4	To print, touch "PRINT" key. To erase stored data, touch "ERASE" key.	

B3 ECCS (Electronically Concentrated Engine Control System)

2. Diagnostic System (Cont'd)

2-3 FAIL-SAFE FUNCTION AND BACKUP FUNCTION

The fail-safe function ensures the safety of the driver and vehicle using the control unit control signals in case of an error in an important system device such as a sensor, etc.

The backup function ensures normal vehicle operation even when an error occurs in a vital sensor. For this purpose, the control unit ignores the signal sent from a failed sensor like this and outputs prearranged control signals.

When the backup function is operating, the fault alarm mode is set and the exhaust gas temperature warning lamp flashes in the combination meter.

Item	Description of problem	Fail-safe or backup	Alarm indication
CPU backup	When detecting error in internal circuit of control unit	<ul style="list-style-type: none"> ● Ignition timing is fixed at a specified value. ● Fuel injection is fixed in 3 patterns: start-time injection, idling injection and driving injection. 	<ul style="list-style-type: none"> ● Exhaust gas temperature warning lamp flashes in 1-sec intervals. ● Reduce driving speed when CPU backup is performed.
Air flow meter	When intake air quantity signal is disconnected during engine operation.	<ul style="list-style-type: none"> ● There are two air flow meters to provide a backup meter if one is faulty (which enables almost normal operation). If both meters malfunction, the fail-safe function is set. ● Fuel injection pulse width is fixed at a specified value. ● Fuel is cut off at 2,400 rpm. 	("12" is indicated in self-diagnosis mode.)
Engine temperature sensor	When short-circuited or disconnected.	Normal engine operation is enabled.	("13" is indicated in self-diagnosis mode.)
Detonation sensor	When short-circuited or disconnected.	A maximum 5° angle is delayed in knock control area.	("34" is indicated in self-diagnosis mode.)
Throttle sensor backup	When short-circuited (approx. 0.2V max.) or disconnected (approx. 5V min.) during engine operation.	Idle judgment is switched from a software switch (throttle sensor) to mechanical switch (throttle valve switch).	("43" is indicated in self-diagnosis mode.)

B3 ECCS (Electronically Concentrated Engine Control System)

2. Diagnostic System (Cont'd)

2-4 DATA MONITOR

The data monitor can be utilized when performing troubleshooting or trouble diagnosis according to the self-diagnosis results.

CONSULT performs monitoring (display and recording) and printing of the ECCS control unit input and output signal data. In case of engine malfunction or engine stall, the data before and after occurrence of the error can be recorded by manual or automatic operation.

(1) Monitoring items and description

Some monitor items are not applicable to all vehicles. (Inapplicable items are not displayed.)

Monitor item	Unit	Description	Remarks
CAS. RPM (POS)	rpm	Engine rpm computed from POS (1°) signal sent from crank angle sensor	Accuracy slightly lowered at less than idle speed.
AIR FLOW METER	V	Air flow meter output voltage	Voltage is fixed at approximately 0V when engine is stopped.
AIR FLOW METER-R			
ENG TEMP SEN	°C °F	Engine temperature value converted from engine temperature sensor voltage	If disconnection or short-circuit occurs in sensor circuit, fail-safe function is activated and engine temperature is fixed at a certain level. (The value increases until a certain value of the timer is reached right after the ignition switch is turned ON.)
EXH GAS SEN	V	Exhaust gas sensor output voltage	Sensor output is fixed at 0V when engine is stopped.
EXH GAS SEN-R			
M/R F/C MNT	(RICH/ LEAN)	Air-fuel ratio of exhaust gas sensor signal during air-fuel ratio feedback control RICH: Sensor detects rich mixture and control is performed to reduce mixture ratio. LEAN: Sensor detects lean mixture and control is performed to increase mixture ratio.	<ul style="list-style-type: none"> ● After turning ignition switch "ON", "LEAN" status is displayed until air-fuel ratio feedback control starts. ● If clamp occurs, the status just before clamp occurrence is indicated.
M/R F/C MNT-R			
CAR SPEED SEN	km/h, mph	Value computed from vehicle speed sensor signal	—
BATTERY VOLT	V	ECCS control unit power supply voltage	—
THROTTLE SEN		Throttle sensor output voltage	—
INT/A TEMP SEN	°C °F	The value converted from intake temperature sensor output voltage to intake temperature.	Fail-safe is activated if disconnection or short-circuit occurs and this value is fixed. (The value right after ignition switch is turned ON is increased to a certain value by the timer.)
START SIGNAL	(ON/ OFF)	ON/OFF setting is determined from each signal output.	"OFF" is indicated irrespective of starter signal after starting engine.
IDLE POSITION			Idle judgment determined from throttle sensor output. (When throttle sensor is faulty, a backup is performed using the throttle valve switch.)
AIR COND SIG			—
NEUTRAL SW			—
PW/ST SIGNAL			—
INJ PULSE	msec	Value computed by control unit	A value is indicated with engine stopped.
INJ PULSE-R			

B3 ECCS (Electronically Concentrated Engine Control System)

2. Diagnostic System (Cont'd)

Monitor item	Unit	Description	Remarks
IGN TIMING	BTDC (°)	Value computed by control unit	A fixed value is indicated with engine stopped.
AAC VALVE	%	Value computed by control unit "%%": Proportional solenoid system (Opening increases with numerical value.)	
A/F ALPHA A/F ALPHA-R		Mean value of air-fuel ratio feedback correction factor for each cycle	
AIR COND RLY FUEL PUMP RLY	(ON/ OFF)	Control condition computed by control unit.	
W/G CONT S/V	(ON/ OFF)	Control condition computed by control unit	—
■ VOLTAGE	Voltage probe measurement value is indicated.		
■ PULSE	Pulse probe measurement value is indicated.		

Note: AIR FLOW METER, EXH GAS SEN, M/R F/C MNT, INJ PULSE, A/F ALPHA are monitored independently by cylinders groups 1-3 (-R) and 4-6.

B3 ECCS (Electronically Concentrated Engine Control System)

2. Diagnostic System (Cont'd)

(2) Operation and display

Step	Operation	Display (example)																				
1	Connect CONSULT to diagnostic connector on vehicle.	<div style="display: flex; justify-content: space-between; align-items: center;"> ☆MONITOR ☆NO FAIL <input checked="" type="checkbox"/> </div> <table style="width: 100%; border-collapse: collapse;"> <tr><td>CAS-RPM (POS)</td><td style="text-align: right;">950rpm</td></tr> <tr><td>AIR FLOW MTR</td><td style="text-align: right;">0.92V</td></tr> <tr><td>AIR FLOW MTR-R</td><td style="text-align: right;">0.82V</td></tr> <tr><td>ENG TEMP SEN</td><td style="text-align: right;">57°C</td></tr> <tr><td>EXH GAS SEN</td><td style="text-align: right;">1.44V</td></tr> <tr><td>EXH GAS SEN-R</td><td style="text-align: right;">0.02V</td></tr> <tr><td>M/R F/C MNT</td><td style="text-align: right;">RICH</td></tr> <tr><td>M/R F/C MNT-R</td><td style="text-align: right;">RICH</td></tr> <tr><td>CAR SPEED SEN</td><td style="text-align: right;">0km/h</td></tr> <tr><td>BATTERY VOLT</td><td style="text-align: right;">14.0V</td></tr> </table> <div style="border: 1px solid black; text-align: center; padding: 2px; margin-top: 5px;">RECORD</div>	CAS-RPM (POS)	950rpm	AIR FLOW MTR	0.92V	AIR FLOW MTR-R	0.82V	ENG TEMP SEN	57°C	EXH GAS SEN	1.44V	EXH GAS SEN-R	0.02V	M/R F/C MNT	RICH	M/R F/C MNT-R	RICH	CAR SPEED SEN	0km/h	BATTERY VOLT	14.0V
CAS-RPM (POS)	950rpm																					
AIR FLOW MTR	0.92V																					
AIR FLOW MTR-R	0.82V																					
ENG TEMP SEN	57°C																					
EXH GAS SEN	1.44V																					
EXH GAS SEN-R	0.02V																					
M/R F/C MNT	RICH																					
M/R F/C MNT-R	RICH																					
CAR SPEED SEN	0km/h																					
BATTERY VOLT	14.0V																					
2	Run engine or drive vehicle.																					
3	Select a desired item on "DATA MONITOR" menu.	<div style="display: flex; justify-content: space-between; align-items: center;"> ★RECORD4/8 ☆NO FAIL <input checked="" type="checkbox"/> </div> <table style="width: 100%; border-collapse: collapse;"> <tr><td>CAS-RPM (POS)</td><td style="text-align: right;">950rpm</td></tr> <tr><td>AIR FLOW MTR</td><td style="text-align: right;">0.92V</td></tr> <tr><td>AIR FLOW MTR-R</td><td style="text-align: right;">0.82V</td></tr> <tr><td>ENG TEMP SEN</td><td style="text-align: right;">62°C</td></tr> <tr><td>EXH GAS SEN</td><td style="text-align: right;">1.40V</td></tr> <tr><td>EXH GAS SEN-R</td><td style="text-align: right;">0.90V</td></tr> <tr><td>M/R F/C MNT</td><td style="text-align: right;">RICH</td></tr> <tr><td>M/R F/C MNT-R</td><td style="text-align: right;">RICH</td></tr> <tr><td>CAR SPEED SEN</td><td style="text-align: right;">0km/h</td></tr> <tr><td>BATTERY VOLT</td><td style="text-align: right;">14.0V</td></tr> </table> <div style="border: 1px solid black; text-align: center; padding: 2px; margin-top: 5px;">RECORD</div>	CAS-RPM (POS)	950rpm	AIR FLOW MTR	0.92V	AIR FLOW MTR-R	0.82V	ENG TEMP SEN	62°C	EXH GAS SEN	1.40V	EXH GAS SEN-R	0.90V	M/R F/C MNT	RICH	M/R F/C MNT-R	RICH	CAR SPEED SEN	0km/h	BATTERY VOLT	14.0V
CAS-RPM (POS)	950rpm																					
AIR FLOW MTR	0.92V																					
AIR FLOW MTR-R	0.82V																					
ENG TEMP SEN	62°C																					
EXH GAS SEN	1.40V																					
EXH GAS SEN-R	0.90V																					
M/R F/C MNT	RICH																					
M/R F/C MNT-R	RICH																					
CAR SPEED SEN	0km/h																					
BATTERY VOLT	14.0V																					
4	Press "RECORD" key.																					

① Exhaust gas sensor monitor

Exhaust gas sensor output voltage and RICH/LEAN status are displayed.

Step	Operation	Display (example)										
1	Connect CONSULT to diagnostic connector on vehicle.											
2	Run engine.											
3	Select EXH GAS SEN, EXH GAS SEN-R, M/R F/C MNT and M/R F/C MNT-R items on "DATA MONITOR" menu.	<div style="display: flex; justify-content: space-between; align-items: center;"> ☆MONITOR ☆NO FAIL <input type="checkbox"/> </div> <table style="width: 100%; border-collapse: collapse;"> <tr><td>CAS-RPM (POS)</td><td style="text-align: right;">950rpm</td></tr> <tr><td>EXH GAS SEN</td><td style="text-align: right;">1.23V</td></tr> <tr><td>EXH GAS SEN-R</td><td style="text-align: right;">1.10V</td></tr> <tr><td>M/R F/C MNT</td><td style="text-align: right;">RICH</td></tr> <tr><td>M/R F/C MNT-R</td><td style="text-align: right;">RICH</td></tr> </table> <div style="border: 1px solid black; text-align: center; padding: 2px; margin-top: 5px;">RECORD</div>	CAS-RPM (POS)	950rpm	EXH GAS SEN	1.23V	EXH GAS SEN-R	1.10V	M/R F/C MNT	RICH	M/R F/C MNT-R	RICH
CAS-RPM (POS)	950rpm											
EXH GAS SEN	1.23V											
EXH GAS SEN-R	1.10V											
M/R F/C MNT	RICH											
M/R F/C MNT-R	RICH											
4	To record data, press "RECORD" key.											

B3 ECCS (Electronically Concentrated Engine Control System)

2. Diagnostic System (Cont'd)

② Switch ON/OFF

The ON/OFF status of each switch is indicated.

Step	Operation	Display (example)										
1	Connect CONSULT to vehicle's diagnostic connector.	<div style="border: 1px solid black; padding: 5px; width: fit-content; margin: auto;"> <div style="display: flex; justify-content: space-between; align-items: center;"> ☆ MONITOR ☆ NO FAIL <input type="checkbox"/> </div> <table style="width: 100%; border-collapse: collapse;"> <tr><td>START SIGNAL</td><td style="text-align: right;">OFF</td></tr> <tr><td>IDLE POSITION</td><td style="text-align: right;">ON</td></tr> <tr><td>AIR COND SIG</td><td style="text-align: right;">OFF</td></tr> <tr><td>NEUTRAL SW</td><td style="text-align: right;">ON</td></tr> <tr><td>PW/ST SIGNAL</td><td style="text-align: right;">OFF</td></tr> </table> <div style="border: 1px solid black; padding: 2px; text-align: center; margin-top: 5px;">RECORD</div> </div>	START SIGNAL	OFF	IDLE POSITION	ON	AIR COND SIG	OFF	NEUTRAL SW	ON	PW/ST SIGNAL	OFF
START SIGNAL	OFF											
IDLE POSITION	ON											
AIR COND SIG	OFF											
NEUTRAL SW	ON											
PW/ST SIGNAL	OFF											
2	Run engine or drive vehicle.											
3	Select each switch on "DATA MONITOR" menu.											
4	Set operating condition for applicable switch and check ON/OFF display.											

Diagnosis item

- (1) Ignition switch START signal system
- (2) Air conditioner switch signal system
- (3) Neutral switch signal system
- (4) Power steering switch signal system
- (5) Throttle position (throttle sensor system)

③ Real-time diagnosis

Although the diagnosis items are the same as those listed in item (2) Self-diagnosis, and Switch ON/OFF in section 2-2, this diagnostic mode provides higher detection capability than the self-diagnosis mode (2).

Step	Operation	Display (example)
1	Connect CONSULT to vehicle's diagnostic connector.	<div style="border: 1px solid black; padding: 5px; width: fit-content; margin: auto;"> <div style="display: flex; justify-content: space-between; align-items: center;"> ■ REAL-TIME DIAG ■ <input type="checkbox"/> </div> <p style="text-align: center; margin-top: 5px;">ENGINE TEMP SENSOR</p> <div style="border: 1px solid black; padding: 2px; text-align: center; margin-top: 5px;">STORE (RECORD1)</div> <div style="display: flex; justify-content: space-around; margin-top: 5px;"> <div style="border: 1px solid black; padding: 2px;">RECORD2</div> <div style="border: 1px solid black; padding: 2px;">DISPLAY</div> </div> </div>
2	Run engine or drive vehicle.	
3	Check using "DATA MONITOR" REAL-TIME DIAG mode. [If any abnormality is detected, data monitoring is stopped and data is recorded automatically.]	

B3 ECCS (Electronically Concentrated Engine Control System)

2. Diagnostic System (Cont'd)

2-5 ACTIVE TEST

The active test mode is utilized to examine the problem diagnosis according to self-diagnosis results and data monitor results. CONSULT gives driving signals to the actuators while isolating the on-board ECCS control unit, to check if the actuator is functioning normally.

(1) Test items and description

Some test items do not apply to all vehicle models. (Inapplicable items are not displayed.)

Active test item	Description
FUEL INJECTION	Varies air-fuel ratio.
AAC VALVE OPENING	Sets control value (opening).
ENGINE TEMPERATURE	Sets engine temperature.
IGNITION TIMING	Sets delay angle correction value.
POWER BALANCE	Fixes AAC valve opening and can stop specified injector operation. Engine speed at this time can be displayed.
FUEL PUMP RELAY	Turns ON/OFF.
SELF-LEARNING CONT	Clears learned data on air-fuel ratio feedback correction factor.

(2) Operation and display

Step	Operation	Display (example)
1	Connect CONSULT to vehicle diagnostic connector.	
2	Run engine or drive vehicle.	
3	Select desired test item on "ACTIVE TEST" menu.	
4	Press "START" key and input a set value.	

- Note:
- The set value will be canceled if test is terminated, canceled or power is turned OFF (CONSULT power OFF, ignition switch OFF, disconnection of battery terminal) during active test.
 - If the diagnostic connector is disconnected during active test, the active test set status is maintained until the ignition switch is turned OFF.

B3 ECCS (Electronically Concentrated Engine Control System)

2. Diagnostic System (Cont'd)

2-6 WORK SUPPORT

CONSULT can be used as a powerful aid for idling checks and other engine tune-up operations. It issues instructions to the ECCS control unit to perform control and displays the input and output signal data being used. Actual tune-up operation (for example, turning adjustment screw, etc.) must be performed manually by the mechanic.

(1) Support items and description

Work support item	Description
AAC VALVE ADJ	Fully closes AAC valve and displays idling rpm.
THROTTLE SENSOR ADJ	Closes AAC valve completely and displays throttle sensor output voltage.

Note: Although it is possible to adjust the "IGNITION TIMING", this adjustment should not be performed because it may cause the timing to become unstabilized.

(2) Operation and display

Step	Operation	Display (example)
1	Connect CONSULT to vehicle diagnostic connector.	<div style="border: 1px solid black; padding: 5px; margin-bottom: 5px;"> <p style="text-align: center;">■ AAC VALVE ADJ ■</p> <p>SET ENGINE RPM AT THE SPECIFIED VALUE UNDER THE FOLLOWING CONDITION</p> <ul style="list-style-type: none"> ● ENG WARMED UP ● NO LOAD </div> <div style="border: 1px solid black; padding: 5px; margin-bottom: 5px; text-align: center;"> <p>START</p> </div> <div style="border: 1px solid black; padding: 5px;"> <p style="text-align: center;">■ AAC VALVE ADJ ■ <input type="checkbox"/></p> <p style="text-align: center;">****ADJ MONITOR****</p> <p>CAS-RPM(POS) 612rpm</p> <p style="text-align: center;">— — CONDITION SETTING — —</p> <p>AAC VALVE FIXED</p> <p style="text-align: center;">= = = MONITOR = = =</p> <p>ENG TEMP SEN 83°C</p> <p>IDLE POSITION ON</p> <p>AIR COND SIG OFF</p> </div>
2	Run engine.	
3	Select desired item on "WORK SUPPORT" menu.	
4	Press "START" key and execute operation.	

Note: The work support mode is maintained until ignition switch is turned OFF if the diagnostic connector is disconnected or while CONSULT is being used as a support.

B3 ECCS (Electronically Concentrated Engine Control System)

3. Basic Inspection

Inspect the three elements of combustion (1. Is fuel injected? 2. Does the spark arc? 3. Does the AAC valve work?) and determine if the faulty system is the fuel system, ignition system or idle control system.

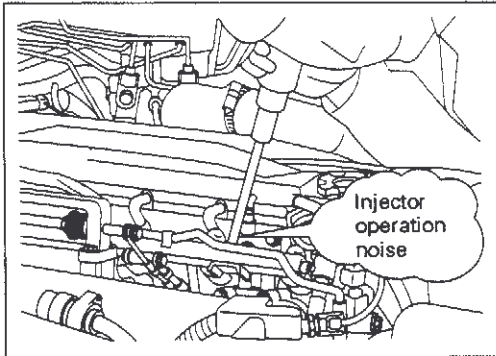

3-1 INJECTOR OPERATION INSPECTION

- Place a stethoscope or screwdriver on the injector and check for injector operation noise (click, click, click) while cranking engine.
If NG: Inspect the injector control circuit.

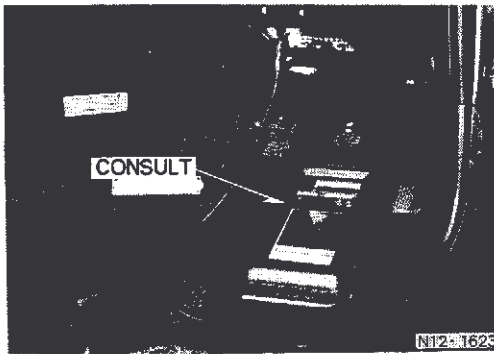

3-2 FUEL PUMP INSPECTION



- Connect CONSULT to the diagnosis terminal on the side of the vehicle (near fuse block).
Note: See B3, 2.2-2 (2)

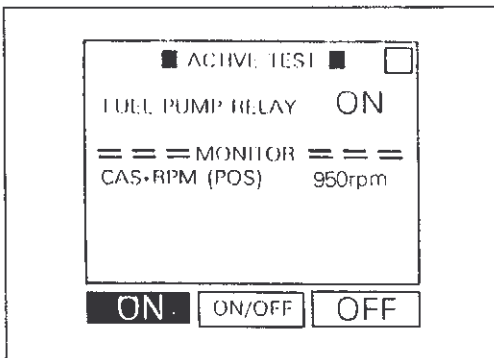

- Turn the ignition switch "ON" and select the "ACTIVE TEST" mode. Press the operation key when "FUEL PUMP RELAY" is displayed and check for pump operation noise.

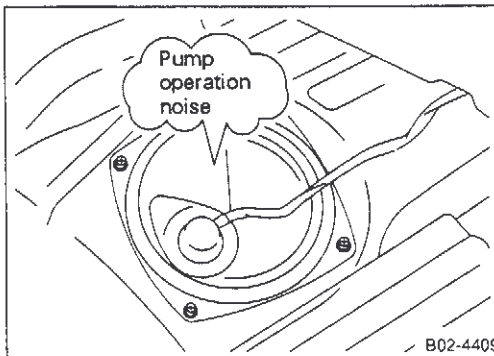

- After turning ignition switch "ON", check for fuel pump operation noise for 5-sec interval.
- There must be a fuel pump operation noise while cranking engine.
If NG: Inspect fuel pump control circuit.

B3 ECCS (Electronically Concentrated Engine Control System)

3. Basic Inspection (Cont'd)

3-3 FUEL PRESSURE INSPECTION

(1) Simple inspection

- When the fuel pump is operating, press the hose between fuel filter and fuel gallery with a finger. There must be tension and pulsations in the hose.

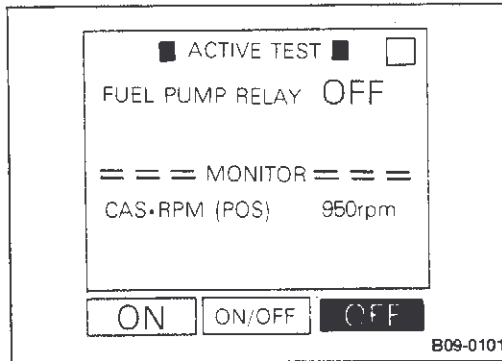
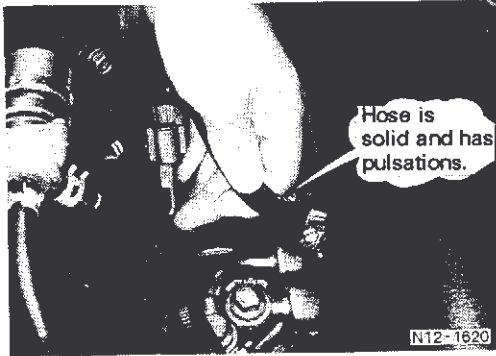

- Run the engine.
- Select the "FUEL PUMP RELAY" item in the "ACTIVE TEST" mode.
- Press the OFF button to release fuel pressure.

(2) Inspection using fuel pressure gauge

Fuel pressure release



- After starting engine, remove fuel pump fuse. Crank engine 2 or 3 times to remove fuel in lines.
- When engine will not start, remove pump fuse and crank engine 4 to 5 times to remove fuel in lines.

Note: The battery may become weak easily, so use booster cables to connect it to another vehicle or battery if necessary.

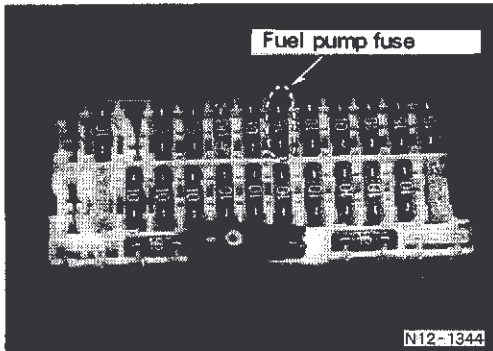

Fuel pressure gauge installation

- Connect the fuel pressure gauge between the fuel strainer and fuel gallery.
- Install the fuel pump fuse.
- Start engine and check if fuel pressure reaches standard value.

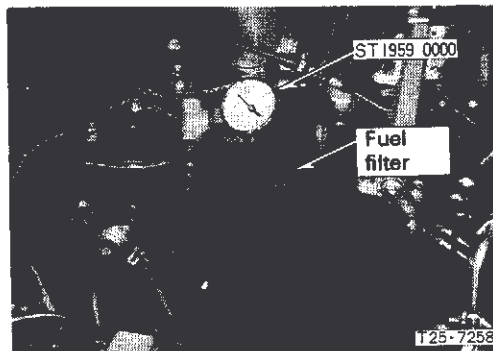

Fuel pressure inspection

Unit: kPa (kg/cm², psi)

Condition	Engine	RB26DETT
	Idling	
When pressure regulator vacuum hose is removed		Approx. 294 (3.0, 43)

B3 ECCS (Electronically Concentrated Engine Control System)

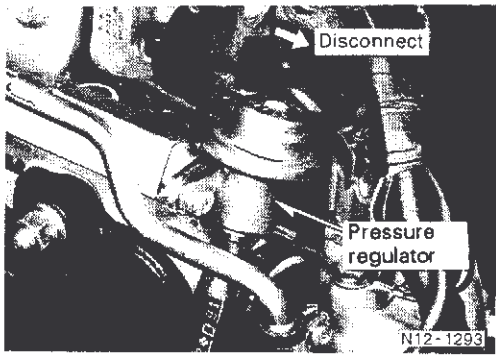

3. Basic Inspection (Cont'd)

- In vehicles with starting problems, turn ignition switch ON and check fuel pressure for 5-sec interval when fuel pump is rotating.

Condition	Engine	RB26DETT
Ignition switch "ON" for 5-sec interval		Approx. 294 kPa (3.0 kg/cm ² , 43 psi)

If NG:

Fuel pressure is abnormally high.	<ul style="list-style-type: none"> ● Pressure regulator is faulty. ● Return system is clogged or hose is bent.
Fuel pressure is abnormally low.	<ul style="list-style-type: none"> ● Pressure regulator is faulty. ● Fuel pump output is faulty. ● Fuel supply system is clogged.

Note: The fuel pressure should be also checked when the engine speed is increased.

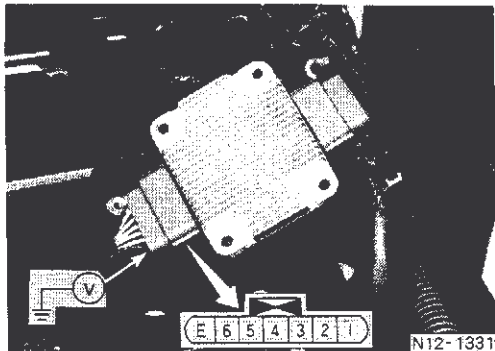

3-4 SPARK INSPECTION

- Measure the voltage with a test probe at power transistor coil side terminal for spark signal of the primary system.

Terminals 1 - 6 when cranking engine Approx. 9.5V

- Primary system check can also be performed by timing light or tachometer needle deflection.

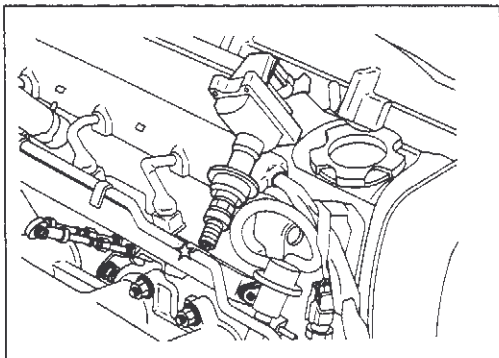

- To check if spark actually arcs or not, remove ignition coil (No. 1 cylinder is easiest), connect spark plug and place it against collector or other part for ground. Check if spark arcs when engine is cranked.

If NG: Inspect ignition control system.

3-5 AAC VALVE OPERATION INSPECTION



- Start the engine.
- Set any angle in the "AAC VALVE OPENING" item of "ACTIVE TEST" mode.
- Check if idle speed at this time varies from set value.

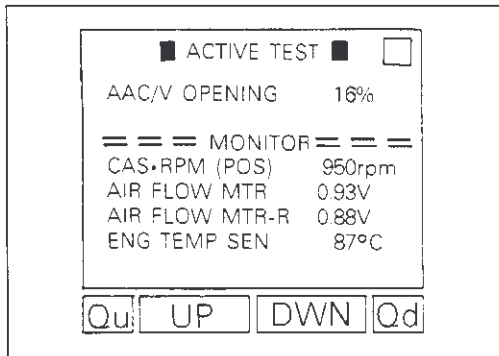

B3 ECCS (Electronically Concentrated Engine Control System)

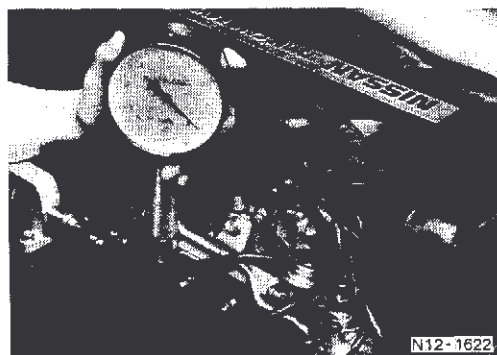
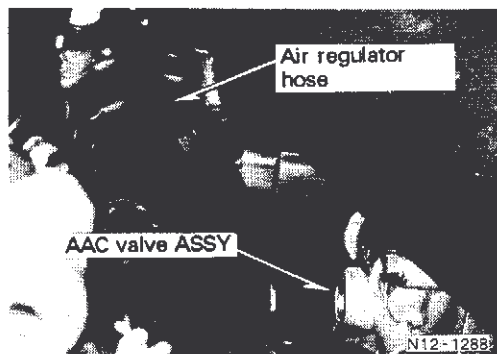
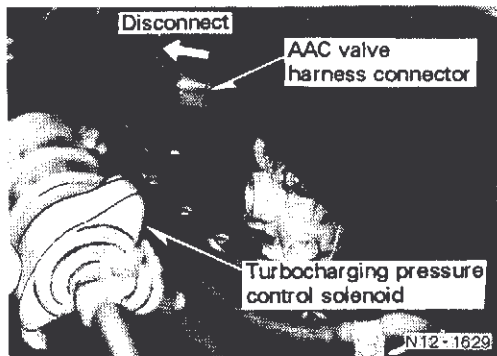

3. Basic Inspection (Cont'd)

- After warming engine, check if idle speed lowers from specified value when AAC valve connector is removed.

3-6 AIR REGULATOR OPERATION INSPECTION

- Start engine when cold, and check if idle speed lower when air regulator hose is closed or partially pressed.
- Start engine when cold and check if specified idle speed increases after AAC valve connector is removed and engine warms up.
- Connect AAC valve connector, and warm up engine adequately.
- After warming up, remove AAC valve connector again and check if idle speed gradually decreases below specified value.

3-7 INTAKE MANIFOLD VACUUM

- After warming up engine, check vacuum when idling.

Reference	Approx. -64.0 kPa (-480 mmHg, -18.90 inHg)
-----------	--

- The vacuum value will be abnormal if there are air leak or other problems with combustion or main engine body. Locate and correct the cause of problem.

4. System Figure and Circuit Diagram

4-1 SYSTEM FIGURE (RB26DETT)

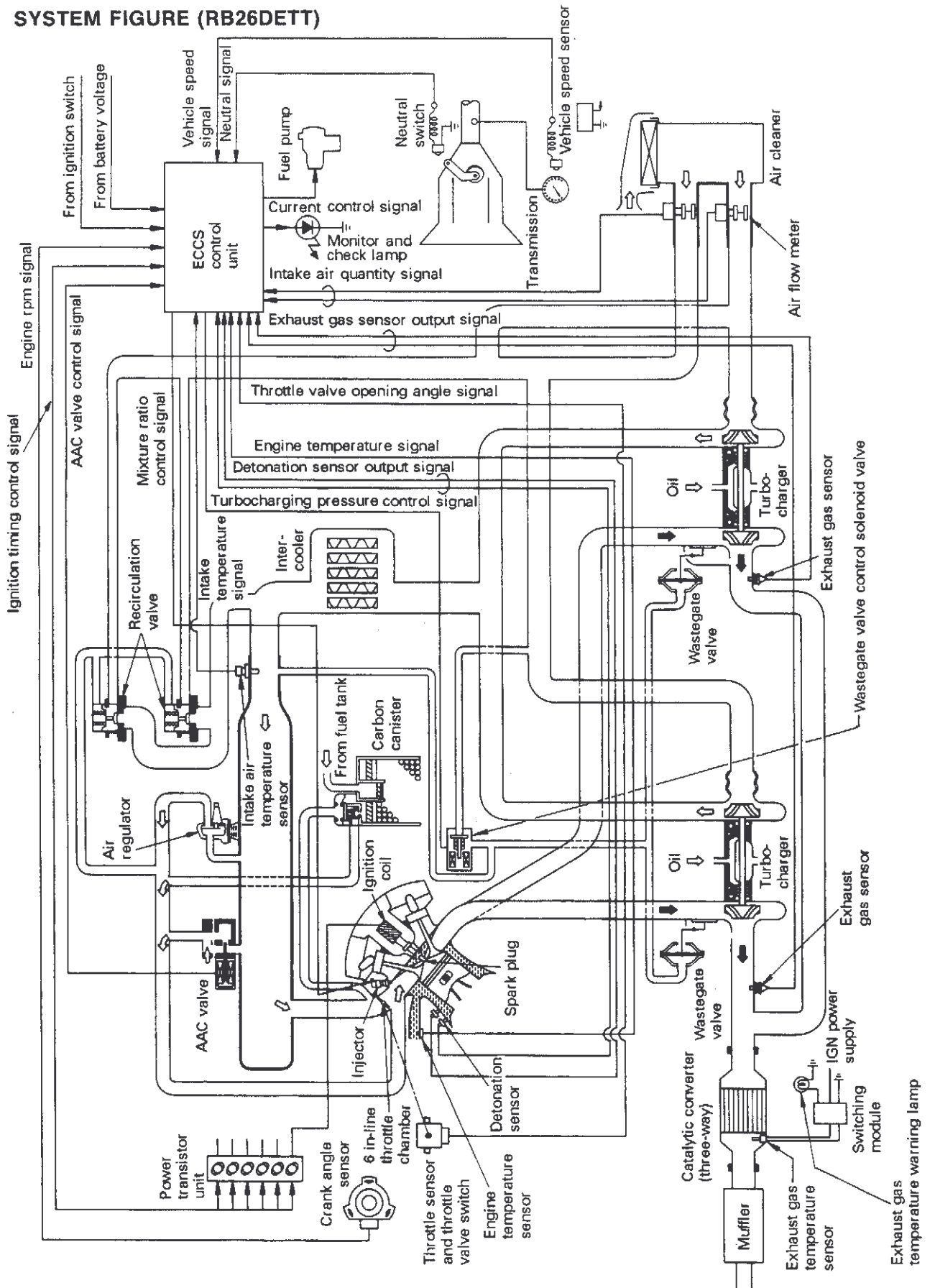

B3 ECCS (Electronically Concentrated Engine Control System)

4. System Figure and Circuit Diagram (Cont'd)

4-2 CIRCUIT DIAGRAM (RB26DETT)

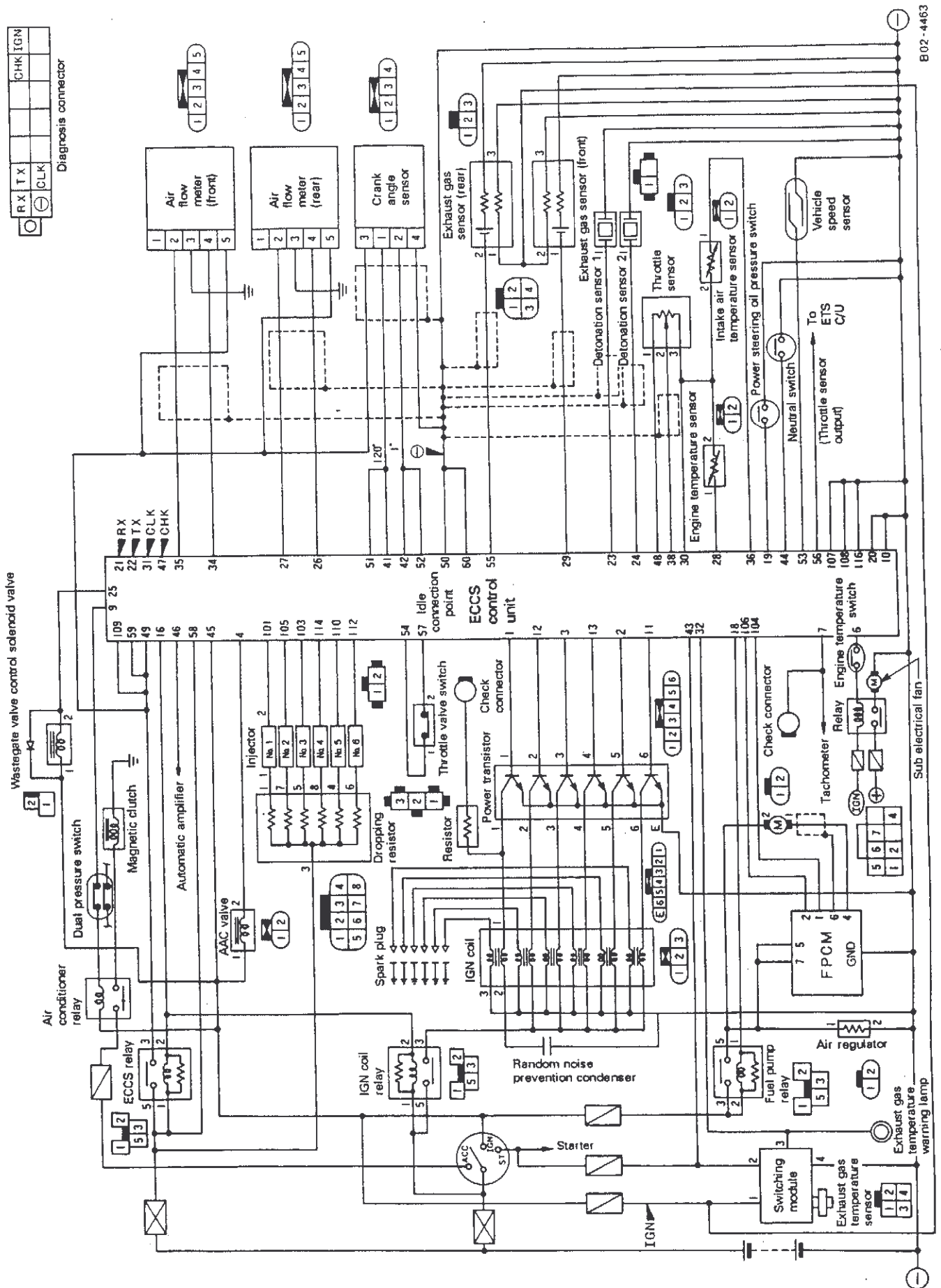

B02-4463

B3 ECCS (Electronically Concentrated Engine Control System)

4. System Figure and Circuit Diagram (Cont'd)

ECCS control unit pin layout figure: RB26DETT



B02-3431

Terminal number	Description	Terminal number	Description
1	Ignition signal (power transistor) Cyl. No. 1	11	Ignition signal (power transistor) Cyl. No. 6
2	Ignition signal (power transistor) Cyl. No. 5	12	Ignition signal (power transistor) Cyl. No. 2
3	Ignition signal (power transistor) Cyl. No. 3	13	Ignition signal (power transistor) Cyl. No. 4
4	AAC valve	14	—
5	—	15	—
6	Sub electrical fan relay (engine temperature switch)	16	ECCS relay
7	Tachometer speed signal	17	—
8	—	18	Fuel pump relay
9	Air conditioner relay (air condi- tioner cut signal)	19	Power steering oil pressure switch
10	Ground (ignition signal system)	20	Ground (ignition signal system)
21 (RX)	Receive (control unit data recep- tion)	31 (CLK)	Clock (synchronization signal)
22 (TX)	Transmit (data sent from control unit)	32	Monitor and check lamp (red)
23	Detonation sensor 1 (cyl 1 to 3)	33	—
24	Detonation sensor 2 (cyl 4 to 6)	34	Air flow meter ground
25	Wastegate valve control solenoid valve	35	Air flow meter intake air quantity signal (front)
26	Air flow meter ground	36	Intake air temperature sensor
27	Air flow meter intake air quantity signal (rear)	37	—
28	Engine temperature sensor	38	Throttle opening output
29	Exhaust gas sensor (front)	39	—
30	Sensor ground (throttle sensor, engine temperature sensor)	40	—
41	Crank angle sensor (120° signal)	51	Crank angle sensor (120° signal)
42	Crank angle sensor (1° signal)	52	Crank angle sensor (1° signal)
43	Ignition switch START signal	53	Vehicle speed sensor
44	Neutral switch	54	Throttle valve switch (idle connec- tion point)
45 (IGN)	Ignition switch (IGN)	55	Exhaust gas sensor (Rear)
46	Air conditioner switch	56	Throttle sensor output signal

B3 ECCS (Electronically Concentrated Engine Control System)

4. System Figure and Circuit Diagram (Cont'd)

47 (CHK)	Check (diagnosis activation)	57	Throttle valve switch power supply
48	Throttle sensor power supply supply	58	Battery power supply
49	Control unit power supply	59	Control unit power supply
50	Ground (control unit)	60 (⊖)	Ground (control unit)
101	Injector No. 1	109	Injector power supply. (counter electromotive reflex circuit)
102	—	110	Injector No. 5
103	Injector No. 3	111	—
104	Fuel pump terminal voltage control output (FPCM) 1	112	Injector No. 6
105	Injector No. 2	113	—
106	Fuel pump terminal voltage control output (FPCM) 2	114	Injector No. 4
107	Injector ground	115	—
108	Injector ground	116	Injector ground

The terminal symbol enclosed in parentheses () is the self-diagnosis connector symbol.

B3 ECCS (Electronically Concentrated Engine Control System)

4. System Figure and Circuit Diagram (Cont'd) ECCS Component Parts

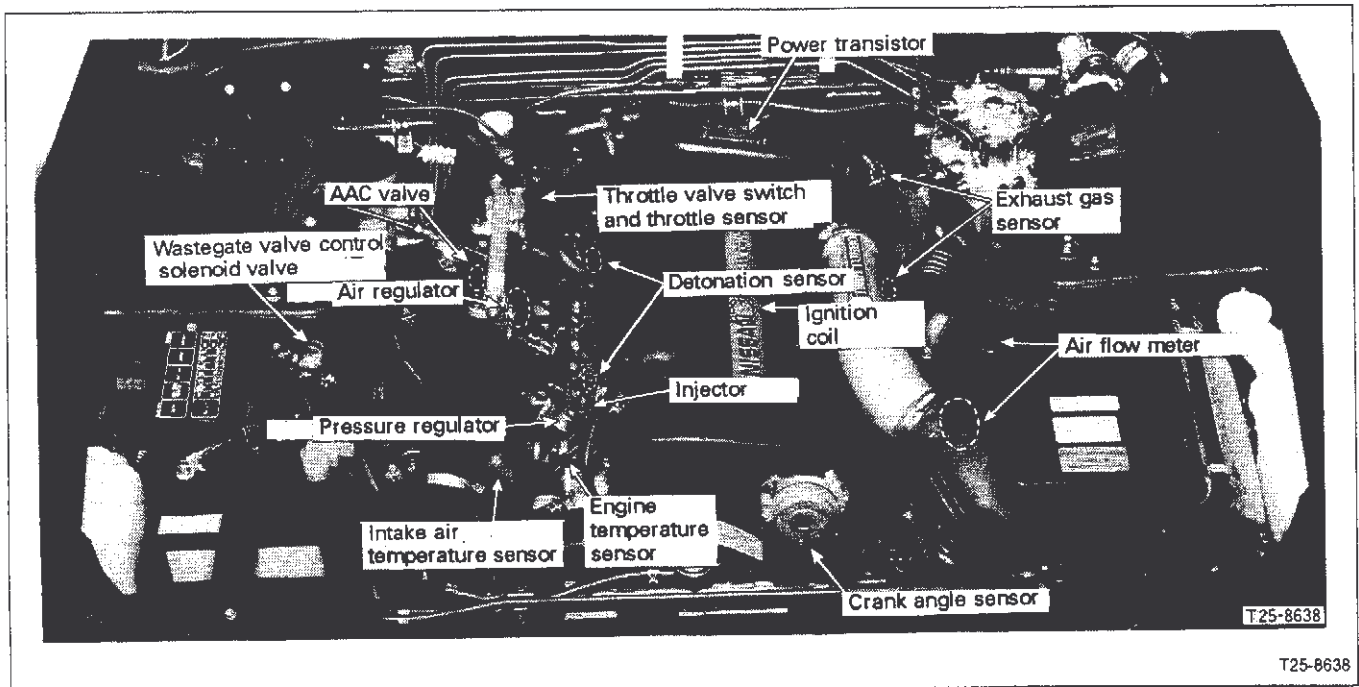

	Component part	Type	Installation position
Actuator system	Wastegate valve control solenoid valve	Solenoid system	Strut tower right
	Pressure regulator	Diaphragm system	Fuel pipe front end
	Injector	Top feed type	Intake manifold
	Fuel pump	Roller vane type	Fuel tank
	Air regulator	Bi-metal type	Intake manifold lower part
	AAC valve	Solenoid type	Intake manifold collector lower part
	Ignition coil	Mini mold type	Cylinder head (above each plug)
	Power transistor unit	For 6-channel low-voltage electronic distribution	Rocker cover ornament
Sensor system	Crank angle sensor	Photocell (camshaft drive)	Cylinder head left front
	Air flow meter (2)	Hot wire type	Front left
	Intake air temperature sensor	Thermistor type	Intake manifold collector
	Throttle sensor	Variable resistor type	Accelerator work unit
	Throttle valve switch	ON/OFF switch	Accelerator work unit
	Engine temperature sensor	Thermistor type	Water outlet
	Exhaust gas sensor	Heater attached (titanium)	Front and rear exhaust outlets
	Detonation sensor	Pressure-electrical type	Cylinder block
	Fuel pump modulator	Operation amplifier	Rear pillar inner

B3 ECCS (Electronically Concentrated Engine Control System)

5. Actuator System Inspection

Use measurement equipment such as a circuit tester, CONSULT electrical system diagnosis tester and oscilloscope to perform the inspection. Refer to item 1., 1-1 (6) for the measurement equipment operation procedures.

The following preparation must be performed when using this equipment.

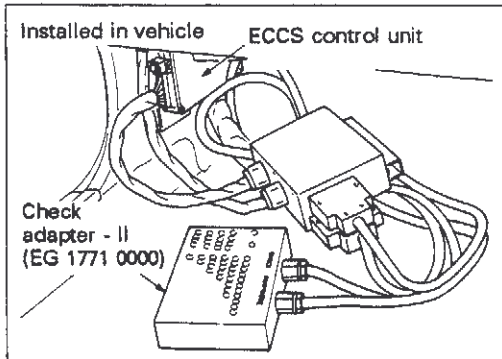

(1) Using circuit tester and oscilloscope

- Use check adapter to perform the measurement.

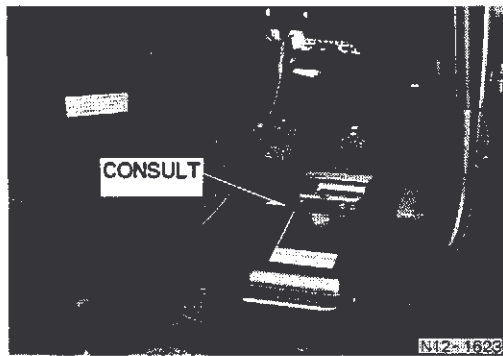

(2) Using CONSULT

- Connect CONSULT to the diagnostic connector on vehicle (near the fuse block).

Note: See section 2, 2-2 (2) for details.

B3 ECCS (Electronically Concentrated Engine Control System)

5. Actuator System Inspection (Cont'd)

5-1 FUEL PUMP SYSTEM INSPECTION

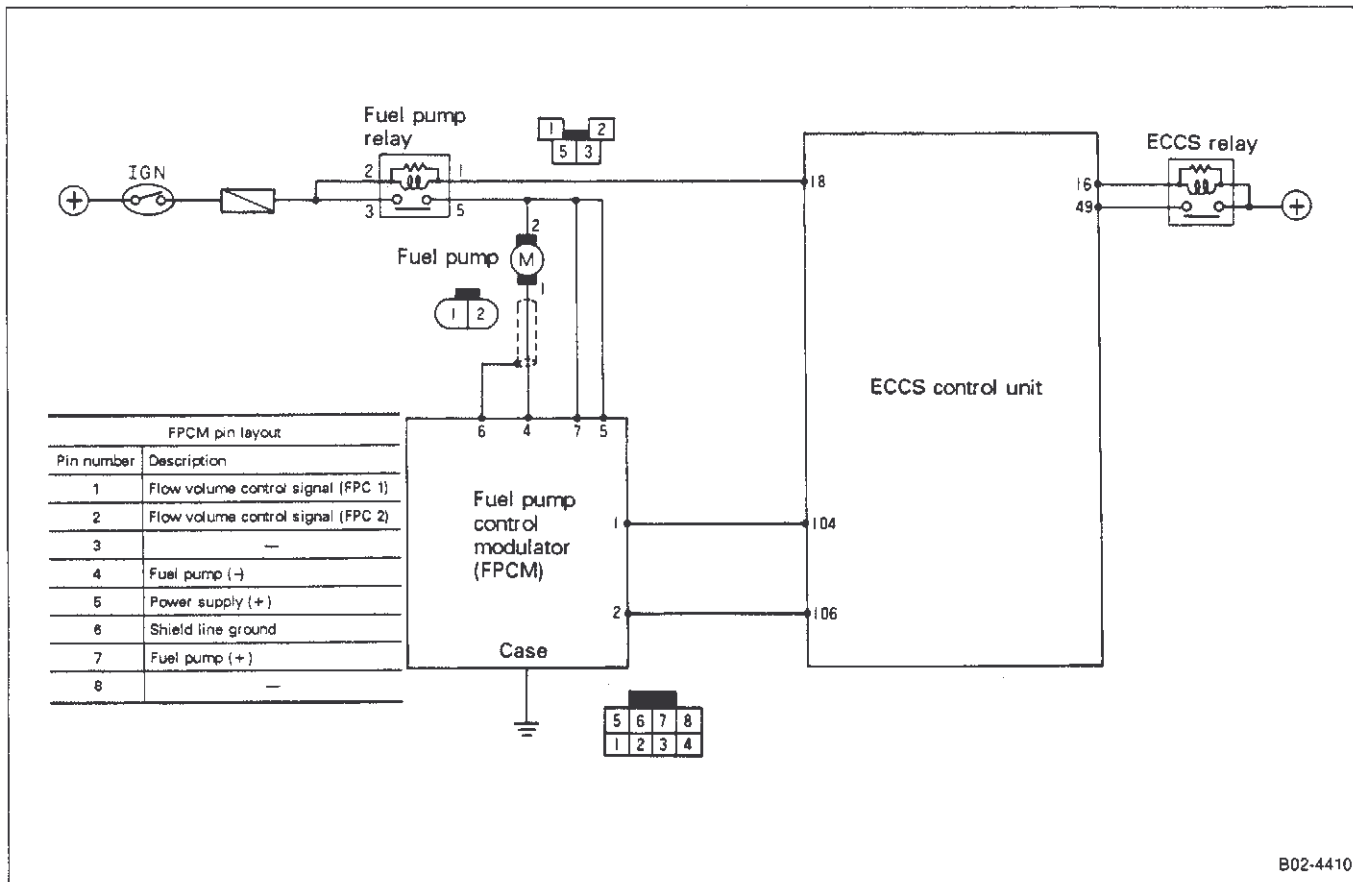

B02-4410

B3 ECCS (Electronically Concentrated Engine Control System)

5. Actuator System Inspection (Cont'd)

Fuel pump system trouble diagnosis flowchart

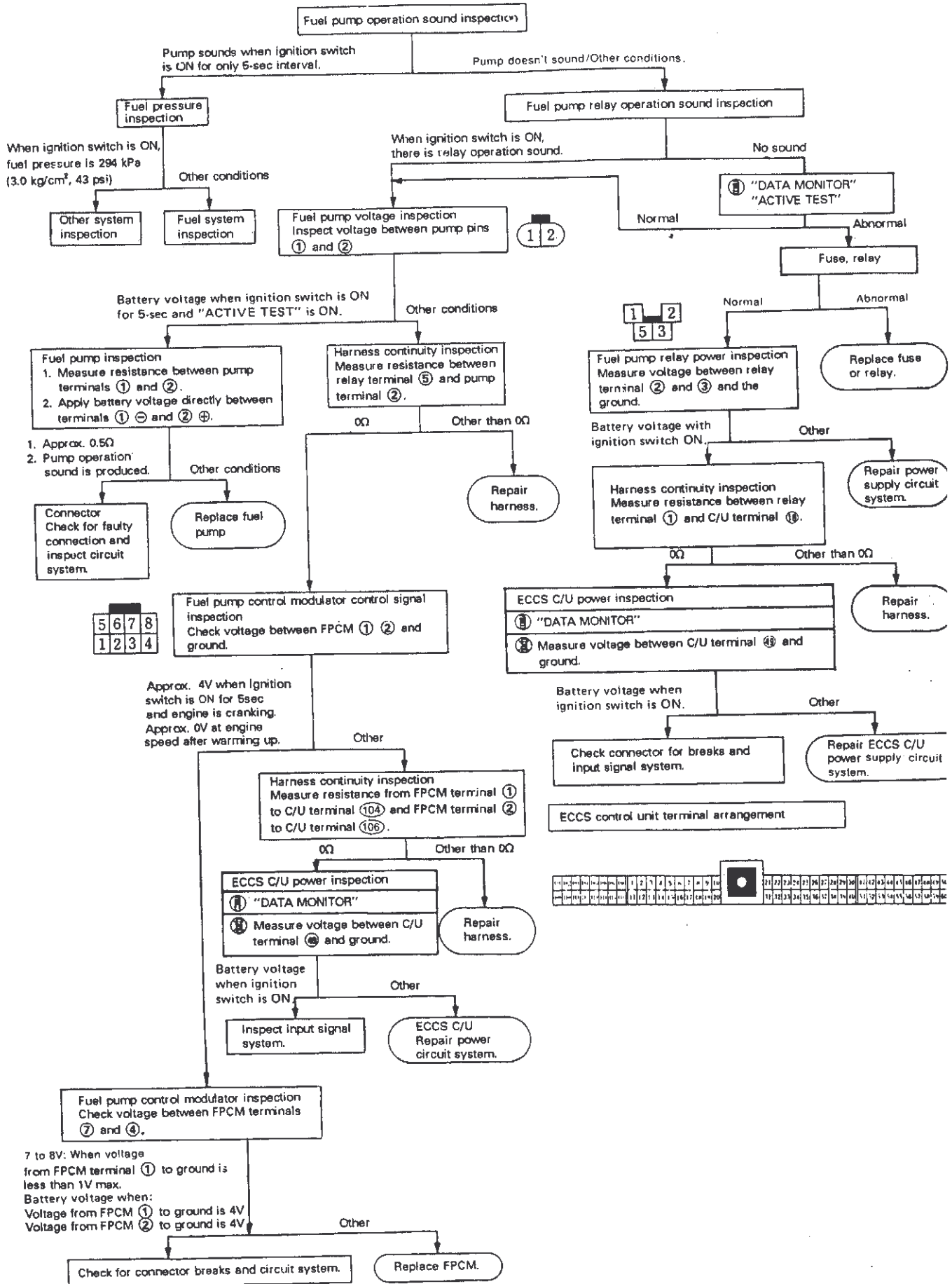

B3 ECCS (Electronically Concentrated Engine Control System)

5. Actuator System Inspection (Cont'd)

(1) Fuel pump relay operation inspection

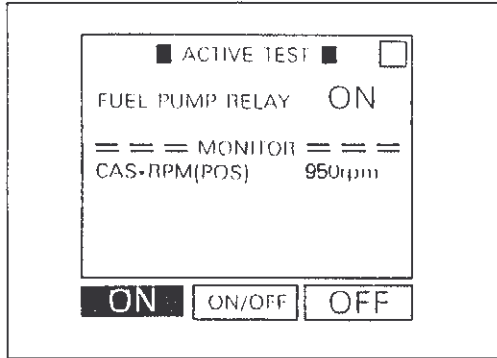

- Turn ignition switch "ON", select "FUEL PUMP RELAY" of "ACTIVE TEST" mode. Press the ON key and check if pump operation makes an operation sound.

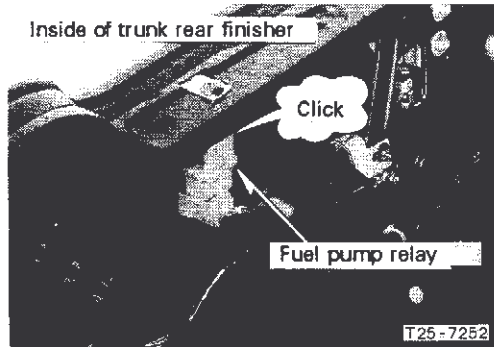

- When the ignition switch is "ON", the relay operation sound must be audible. The pump must sound in 5 sec after relay is turned on.
- After the engine has stopped, turn ignition key to OFF in 1.5 sec.

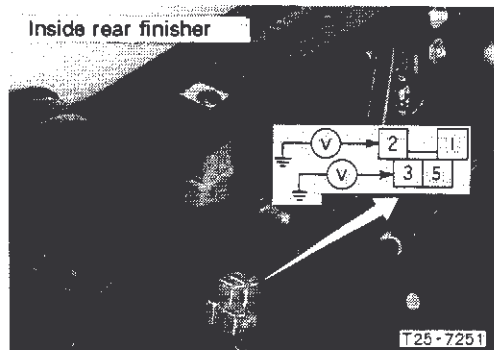

(2) Fuel pump relay power inspection

- Disconnect fuel pump relay and measure the voltage between following terminals and ground when the ignition switch is ON.

Engine	RB26DETT	
Measurement location	Between ground and terminal (2) on fuel pump relay harness side.	Between ground and terminal (3) on fuel pump relay harness side.
Condition		
When ignition switch is ON.	Battery voltage	←

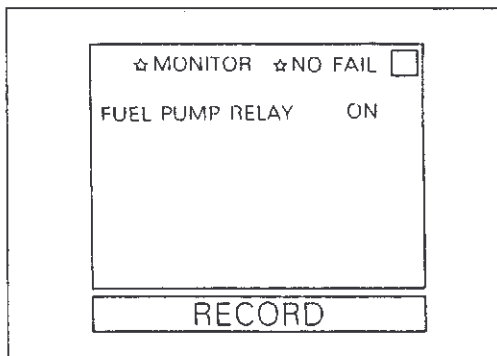

(3) Fuel pump control signal inspection



- Select "FUEL PUMP RLY" item of "DATA MONITOR" mode and check following items.

Condition	Item	Fuel pump relay
When ignition switch is ON (engine is not running)		OFF
When cranking engine		ON
When idling		ON

B3 ECCS (Electronically Concentrated Engine Control System)

5. Actuator System Inspection (Cont'd)

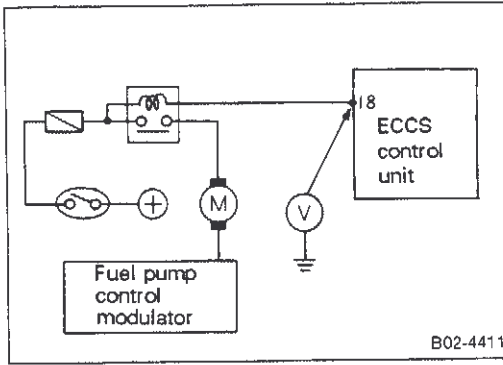

- Measure the voltage between the following terminals and the ground when the ECCS control unit connectors are connected.

Engine		RB26DETT
Measurement location		Between ECCS C/U terminal (18) and ground
Condition	When ignition switch is ON (with engine stopped).	Approx. 1V
	After 5 seconds right after turning switch ON.	Battery voltage
Cranking engine		Approx. 1V
Idling		Approx. 1V

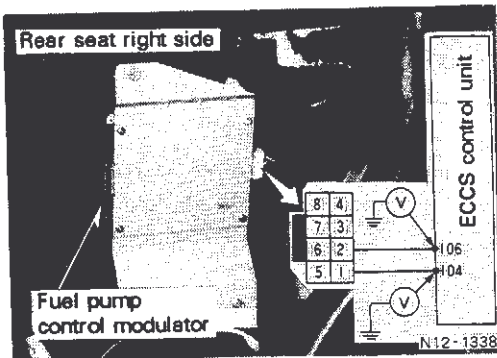

(4) Fuel pump control modulator control signal inspection

- Measure the voltage between the following terminals and the ground when the ECCS control unit connectors are connected.

Engine		RB26DETT	
Measurement location		Between ECCS C/U terminal (104) and ground (FPCM1)	Between ECCS C/U terminal (106) and ground (FPCM2)
Condition	Ignition switch ON (with engine stopped)	Approx. 4V 0V after 5 sec.	←
Starting or with high load		Approx. 4V	←
Idling		Approx. 0V	—
Medium load		Approx. 4V	Approx. 0V

- Check voltage at FPCM terminals 4 and 7.

Measurement location		Between FPCM terminal 4 and ground	Between FPCM terminal 7 and ground
Condition	Idling	Battery voltage – Approx. 6V	Battery voltage
Medium load		Battery voltage – Approx. 8V	
Starting or with high load		Approx. 0V	

B3 ECCS (Electronically Concentrated Engine Control System)

5. Actuator System Inspection (Cont'd)

(5) ECCS control unit power inspection

- Select "BATTERY VOLTAGE" item in "DATA MONITOR" mode and perform the following inspection.

Condition	Item	Battery voltage
Ignition switch ON		11 - 14V

CAUTION:

The same setting as ON state is maintained for a few seconds right after the ignition switch is turned ON → OFF and then ON again.

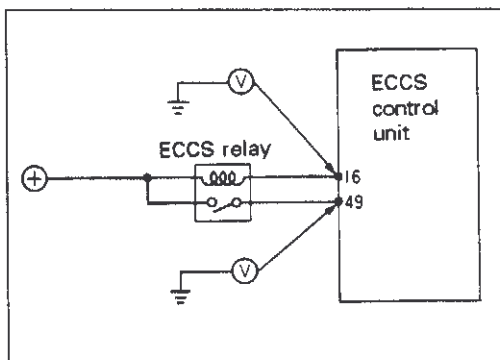

- Measure the voltage between the following terminals and the ground when the ECCS control unit connectors are connected.

Engine	RB26DETT	
Measurement location	Between ECCS C/U terminal (16) and ground	Between ECCS C/U terminal (49) and ground
Condition		
Ignition switch OFF	Battery voltage	Approx. 0V
Ignition switch ON	Approx. 0V	Battery voltage
Cranking	Approx. 0V	Battery voltage
Idling	Approx. 0V	Battery voltage

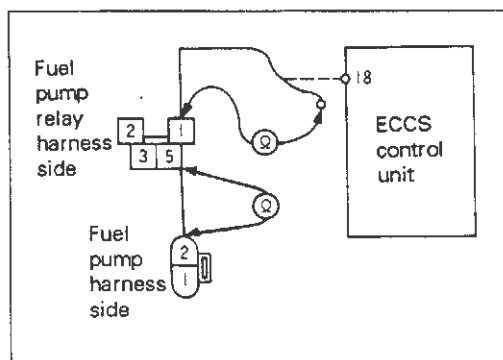

(6) Harness continuity inspection

- Disconnect harness connectors of ECCS control unit, fuel pump relay and fuel pump and measure resistance between the following terminals.

Engine	RB26DETT
Measurement location	
Between ECCS C/U harness terminal (18) and fuel pump relay harness terminal (1)	0Ω
Between fuel pump harness terminal (2) and fuel pump relay harness terminal (5)	0Ω

B3 ECCS (Electronically Concentrated Engine Control System)

5. Actuator System Inspection (Cont'd)

- Remove each connector and measure the resistance between the following terminals.

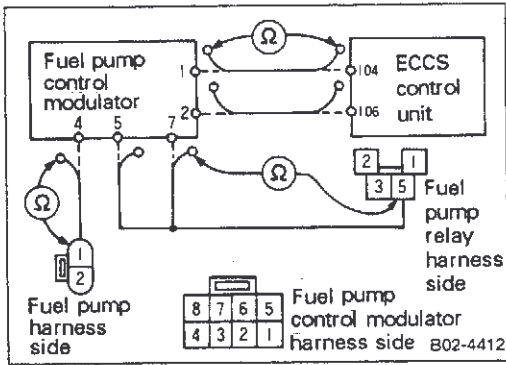

Measurement location	Engine	RB26DETT
Between ECCS C/U terminal (104) and FPCM harness terminal (1)		0Ω
Between ECCS C/U terminal (106) and FPCM harness terminal (2)		
Between fuel pump relay harness terminal (5) and FPCM harness terminal (5)		
Between fuel pump relay harness terminal (5) and FPCM harness terminal (7)		
Between fuel pump harness terminal (1) and FPCM harness terminal (4)		

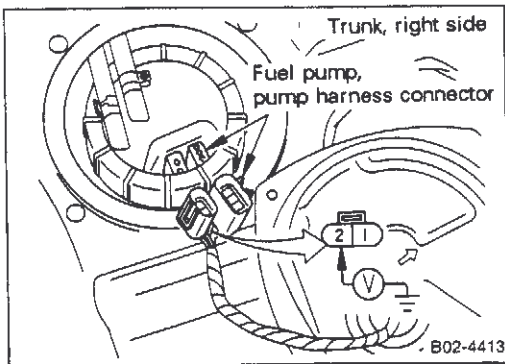

(7) Fuel pump voltage inspection

- Disconnect the fuel pump connector and measure the voltage between the following terminals and ground.

Measurement location	Engine	RB26DETT
Condition		Between fuel pump harness terminal (2) and ground
5 sec after ignition switch is turned ON		Battery voltage
Cranking		Battery voltage

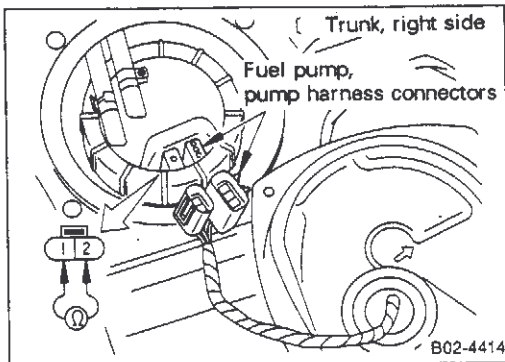

(8) Fuel pump inspection

- Disconnect the fuel pump connector and measure the resistance between the following fuel pump terminals.

Measurement location	Engine	RB26DETT
Between fuel pump terminal (1) and (2)		Approx. $0.4 - 0.7\Omega$

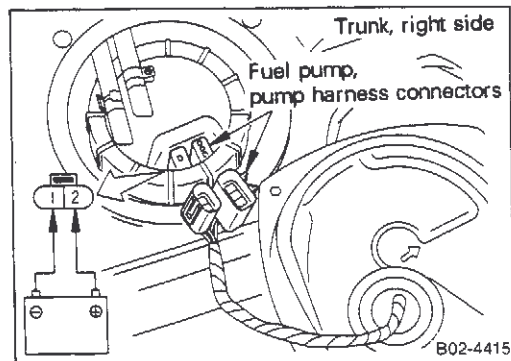

- Disconnect the fuel pump connectors, apply the battery voltage directly to the following fuel pump terminals and check fuel pump operation.

- Pump terminal (2) to battery positive terminal (+)
- Pump terminal (1) to battery negative terminal (-)

CAUTION:

Be careful because damage will occur if connection is made with the incorrect battery polarity. Do not generate any sparks because fuel tank is nearby.

B3 ECCS (Electronically Concentrated Engine Control System)

5. Actuator System Inspection (Cont'd)

(9) Fuel pump control modulator inspection

- When fuel pump control modulator connector is connected, measure the voltage between the following terminals.

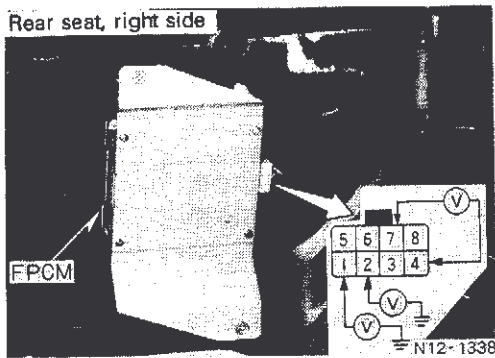

Measurement location	Condition	Voltage between FPCM terminal (1) and ground	Voltage between FPCM terminal (2) and ground
		Voltage between FPCM terminals (7) and (4)	6.6 - 7.0V
		8.8 - 9.2V	Approx. 4V
	Battery voltage	Approx. 4V	←

B3 ECCS (Electronically Concentrated Engine Control System)

5. Actuator System Inspection (Cont'd)

5-2 INJECTOR SYSTEM INSPECTION

[Control circuit diagram]

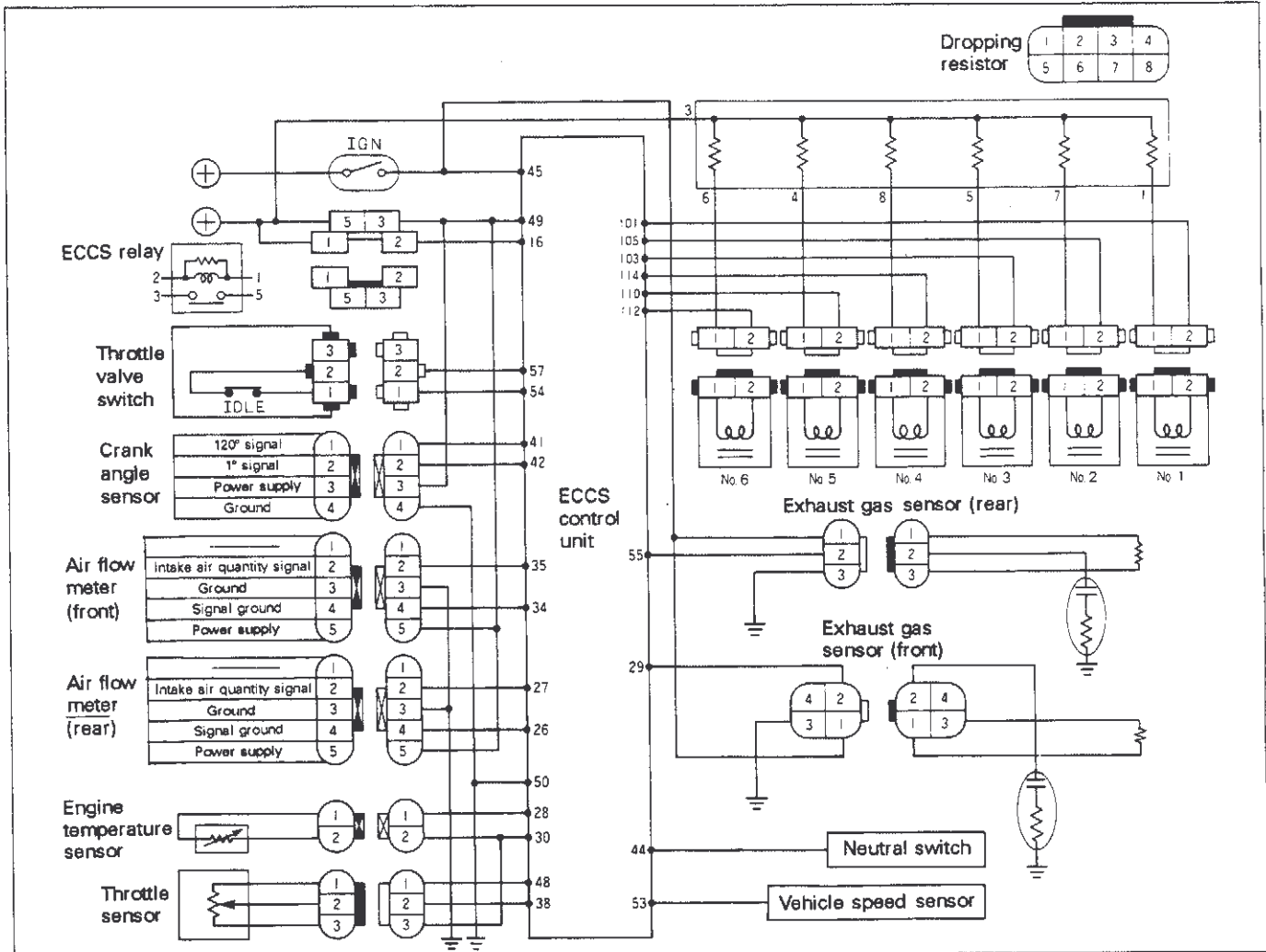

[Control description]

Input signal	Terminal number	Control description	Remarks
Crank angle sensor 120° signal Crank angle sensor 1° signal	41, 51 42, 52	<ul style="list-style-type: none"> ● Determines injector injection timing. ● Reads engine speed. 	—
Air flow meter intake air quantity signal	27, 35	<ul style="list-style-type: none"> ● Detects intake air quantity, and determines basic injection quantity (injection pulse width) based on engine load. 	<ul style="list-style-type: none"> ● Fail-safe function activated when disconnected.
START signal	43	<ul style="list-style-type: none"> ● Increases fuel quantity when starting. Determines injection quantity when starter SW is ON. 	—
Engine temperature sensor signal	28	<ul style="list-style-type: none"> ● Performs injection increase according to engine temperature. ● Fuel cut range changes according to engine temperature. 	<ul style="list-style-type: none"> ● Fail-safe activated when short-circuit or disconnection occurs.
Exhaust gas sensor signal	29, 55	<ul style="list-style-type: none"> ● Injection pulse width control according to air-fuel ratio feedback. 	<ul style="list-style-type: none"> ● According to control block condition.
Throttle valve SW (idle connection point)	54	—	<ul style="list-style-type: none"> ● Activated when throttle sensor damage occurs. ● Idle judgment backup.

B3 ECCS (Electronically Concentrated Engine Control System)

5. Actuator System Inspection (Cont'd)

Input signal	Terminal number	Control description	Remarks
Throttle sensor	38	<ul style="list-style-type: none">● Fuel cut during deceleration● Flow correction during acceleration or deceleration● Interruption injection● Idle judgment● Deceleration fuel cut according to ON signal.● Acceleration increase when ON goes to OFF.	—
Vehicle speed sensor	53	<ul style="list-style-type: none">● Fuel cut interrupts speed and fuel cut at 0 km/h (0 MPH) vehicle speed	—
Battery voltage	49	<ul style="list-style-type: none">● Injection pulse width correction	—
Intake air temperature sensor	36	<ul style="list-style-type: none">● Detects intake air quantity temperature and corrects injection pulse width.	—

B3 ECCS (Electronically Concentrated Engine Control System)

5. Actuator System Inspection (Cont'd)

Injector system trouble diagnosis flowchart

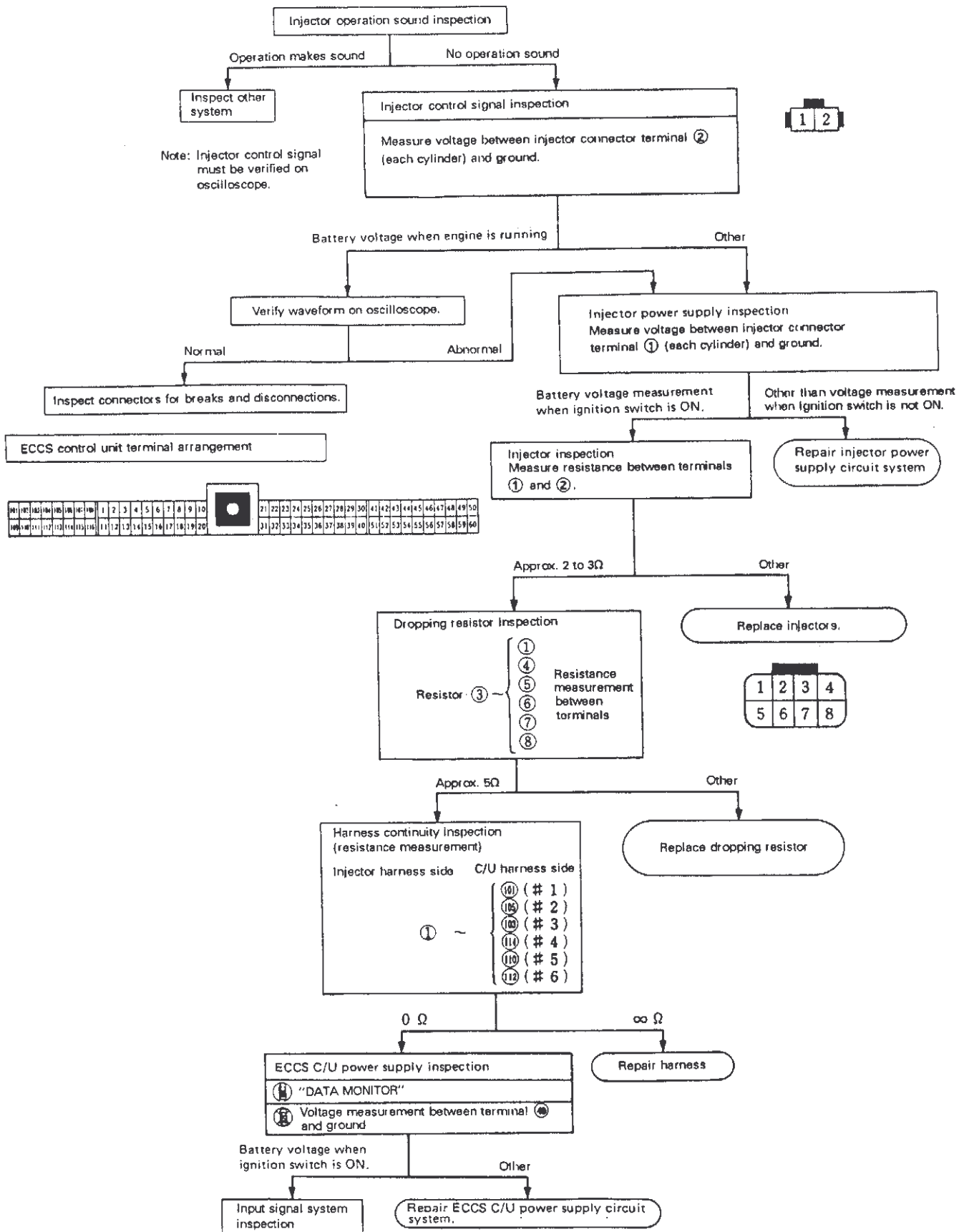

B3 ECCS (Electronically Concentrated Engine Control System)

5. Actuator System Inspection (Cont'd)

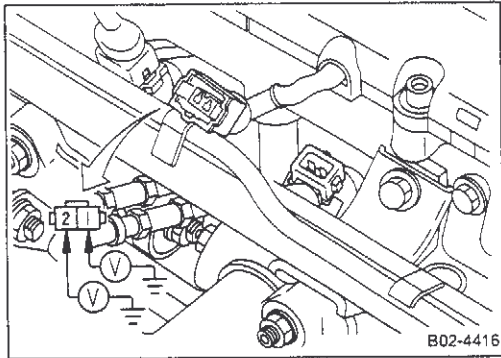
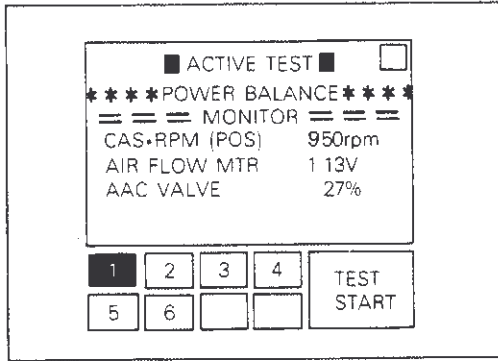

- Use "POWER BALANCE" in the CONSULT active test mode to change the idle speed and check the injector operation.

CAUTION:

- (1) There is a necessary minimum test time limit to prevent error.
- (2) Avoid performing the test during driving.

(1) Injector control signal and power inspection

[Injector connectors]



- Disconnect the injector connectors and measure the voltage between the following terminals and ground.

Engine	RB26DETT		
	Measurement location	Control circuit	Power supply circuit
Condition	Between harness terminal (2) and ground	Between harness terminal (1) and ground	
Ignition switch ON	Battery voltage		←
Cranking engine	Approx. 10V		←
Engine running	The voltage decreases as the engine speed increases (approx. 0.2V decrease for each engine speed increase of 2,000 rpm).		Battery voltage

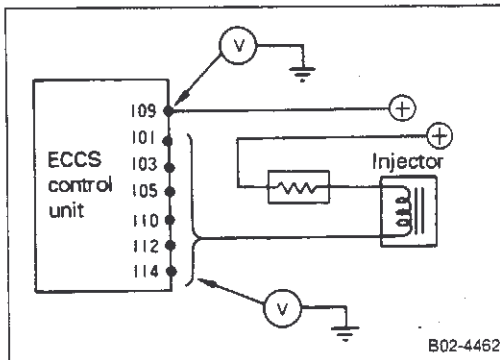

[ECCS control unit connectors]

Engine	RB26DETT		
	Measurement location	Control circuit	Power supply circuit
Condition	Between ECCS C/U terminals (101), (103), (105), (110), (112), (114) and ground	Between ECCS C/U terminal (109) and ground	
Ignition switch ON	Battery voltage		←
Cranking engine	Approx. 10V		←
Engine running	The control unit voltage decreases as the battery voltage and engine speed increases (approx. 0.2V decrease for each engine speed increase of 2,000 rpm).		Battery voltage

(2) ECCS control unit power supply inspection

- Refer to fuel pump system.

B3 ECCS (Electronically Concentrated Engine Control System)

5. Actuator System Inspection (Cont'd)

(3) Harness continuity inspection

- Disconnect the control unit and injector connectors and measure the resistance between the following terminals.

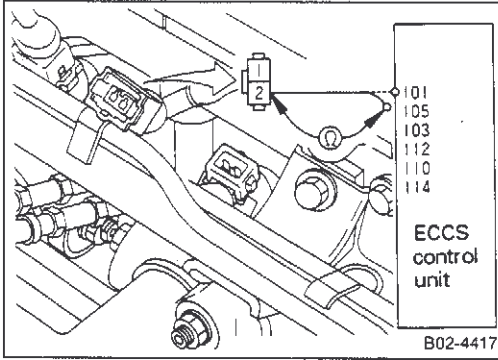

Measurement location		Engine	RB26DETT
ECCS C/U harness	Injector harness terminal (2)		0Ω
Terminal (101)	to	No. 1 cylinder	
Terminal (105)	to	No. 2 cylinder	
Terminal (103)	to	No. 3 cylinder	
Terminal (114)	to	No. 4 cylinder	
Terminal (110)	to	No. 5 cylinder	
Terminal (112)	to	No. 6 cylinder	

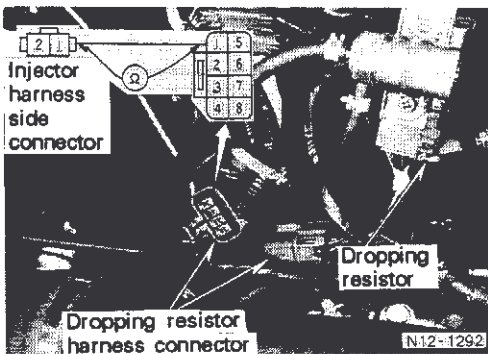

- Disconnect the harness connector from the injector and dropping resistor and measure the resistance between the following terminals.

Measurement location		Engine	RB26DETT
Dropping register harness	Injector harness terminal (1)		0Ω
Terminal (1)	to	No. 1 cylinder	
Terminal (4)	to	No. 5 cylinder	
Terminal (5)	to	No. 3 cylinder	
Terminal (6)	to	No. 6 cylinder	
Terminal (7)	to	No. 2 cylinder	
Terminal (8)	to	No. 4 cylinder	

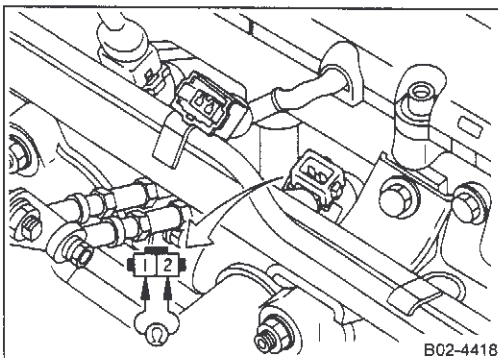

(4) Injector inspection

- Disconnect the injector connectors and measure the resistance between the terminals for each injector.

Measurement location		Engine	RB26DETT
Between injector terminals (1) and (2) (for all cylinders)			Approx. 2 - 3Ω

B3 ECCS (Electronically Concentrated Engine Control System)

5. Actuator System Inspection (Cont'd)

(5) Dropping resistor inspection

- Disconnect the dropping resistor connector and measure the resistance between the following terminals.

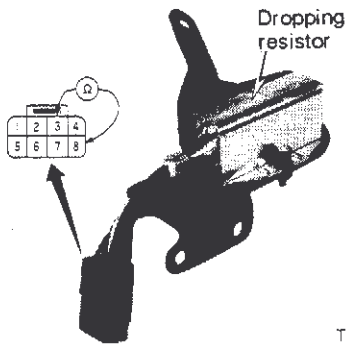

T25-7256

Measurement location		Engine
		RB26DETT
Dropping resistor terminal (3) and	<ul style="list-style-type: none"> Terminal (1) Terminal (4) Terminal (5) Terminal (6) Terminal (7) Terminal (8) 	Approx. 5Ω

B3 ECCS (Electronically Concentrated Engine Control System)

5. Actuator System Inspection (Cont'd)

5-3 IGNITION SYSTEM INSPECTION

[Control circuit]

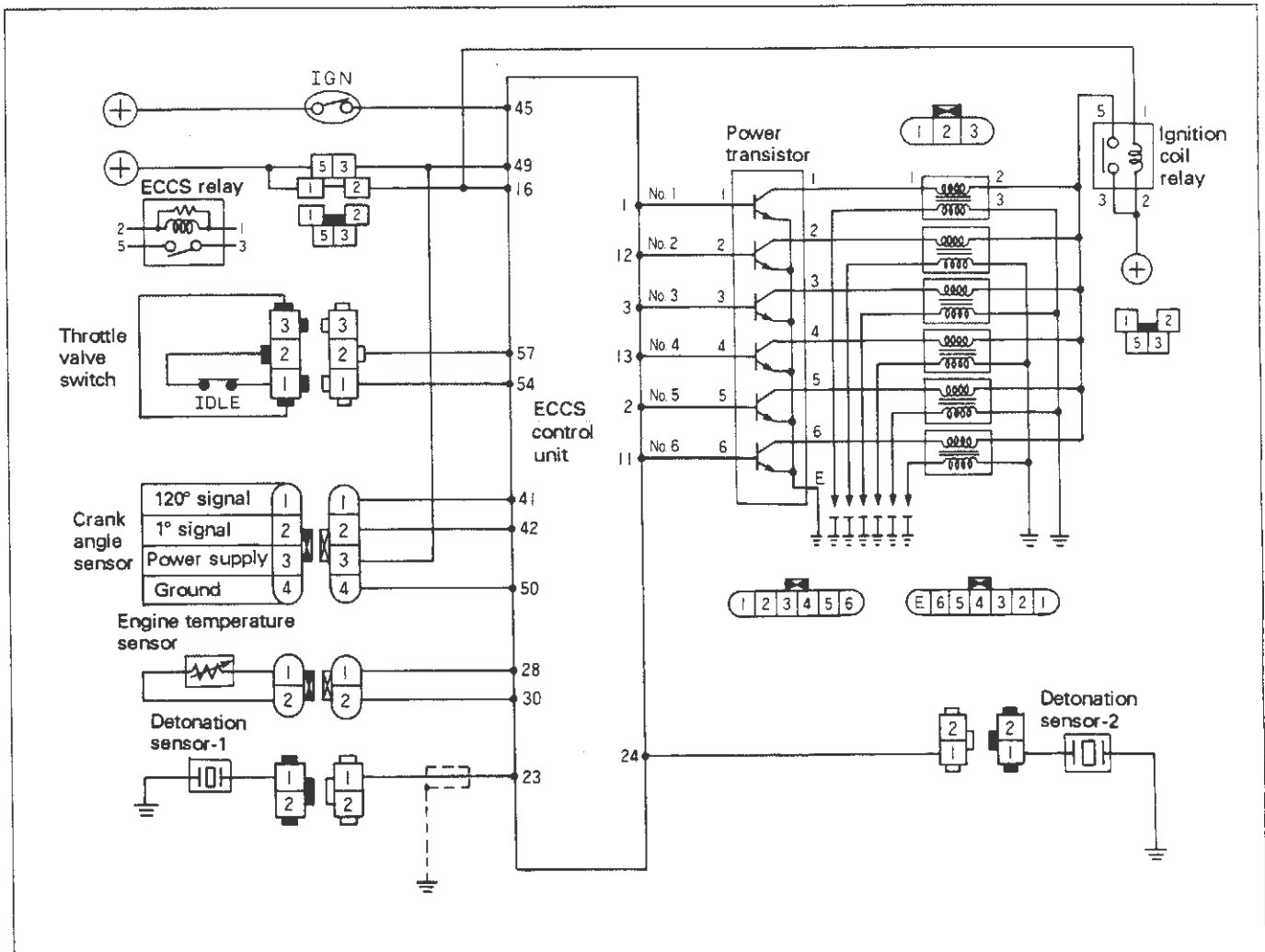

[Control description]

Input signal	Terminal number	Control description	Remarks
Crank angle sensor 120° signal	41, 51	<ul style="list-style-type: none"> Ignition timing start point. 	<ul style="list-style-type: none"> The ignition cannot be performed if there is an instantaneous break in the 120° signal. The ignition cannot be performed if there is an instantaneous break in the 1° signal.
Crank angle sensor 1° signal	42, 52	<ul style="list-style-type: none"> Ignition timing count. The ignition timing is set according to the map indicated by 120° signal. 	
Engine temperature sensor	28	<ul style="list-style-type: none"> Changes injector injection timing according to engine temperature. Control for low and high engine temperature conditions. 	<ul style="list-style-type: none"> Fail-safe is performed when there is a short-circuit or disconnection. [20°C (68°F) at starting, gradually increasing to 80°C (176°F)]
Throttle valve SW (idle connection point)	54	—	<ul style="list-style-type: none"> Activated when throttle sensor damage occurs. Idle judgment backup.

B3 ECCS (Electronically Concentrated Engine Control System)

5. Actuator System Inspection (Cont'd)

Input signal	Terminal number	Control description	Remarks
Throttle sensor	38	<ul style="list-style-type: none">● Fuel cut during deceleration● Flow correction during acceleration or deceleration● Interruption injection● Idle judgment● Deceleration fuel cut according to ON signal.● Acceleration fuel increase during ON-OFF operation.	—
START signal	43	<ul style="list-style-type: none">● Controls ignition timing when cranking engine.	—
Detonation sensor	23, 24	<ul style="list-style-type: none">● Detects detonation and changes ignition timing.	<ul style="list-style-type: none">● Fail-safe is activated if short-circuit or disconnection occurs. (Fixed volume delay angle)

B3 ECCS (Electronically Concentrated Engine Control System)

5. Actuator System Inspection (Cont'd)

Ignition system trouble diagnosis flowchart

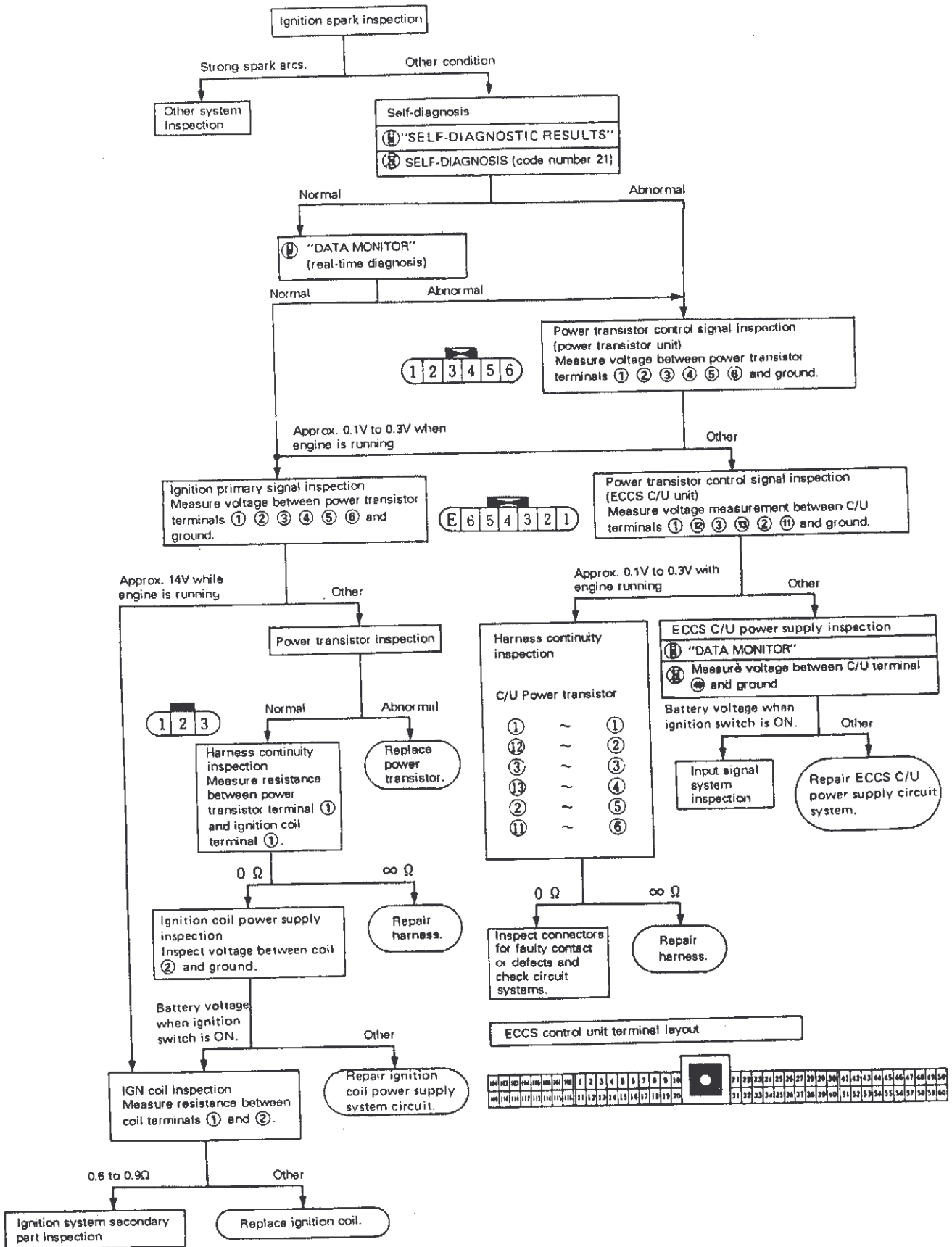

Note: An oscilloscope must be used to check the output waveform of the ignition system.

B3 ECCS (Electronically Concentrated Engine Control System)

5. Actuator System Inspection (Cont'd)

(1) Self-diagnosis

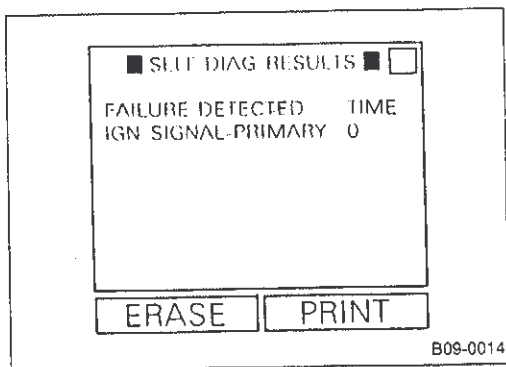

- When the ignition switch is ON and engine is cranking, check faulty system name in "SELF-DIAGNOSTIC RESULTS" mode.

- When there is abnormal output, inspect the assumed locations in the following sequence.

Power transistor (short) → ECCS harness (short) → ECCS control unit



- Set ignition switch to ON.
- Perform the diagnosis mode selection procedure with the diagnosis connector in vehicle. Check the code number of the faulty system displayed by the flashing exhaust gas temperature warning lamp on the instrument panel. (See 2, 2-2, ②.)

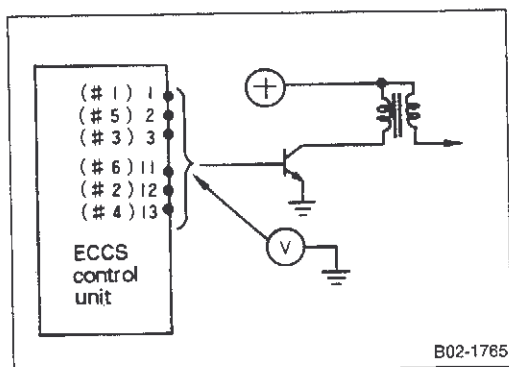

B02-1765

(2) Power transistor control signal inspection

- Measure voltage between the following connectors and ground when ECCS control unit connectors are connected.

Engine	RB26DETT
Measurement location	Voltage between ECCS C/U terminals 1, 2, 3, 11, 12, 13 and ground
Condition	
Cranking	0.2 - 0.3V
Idling	0.2 - 0.3V
2,500 rpm	Approx. 0.4V

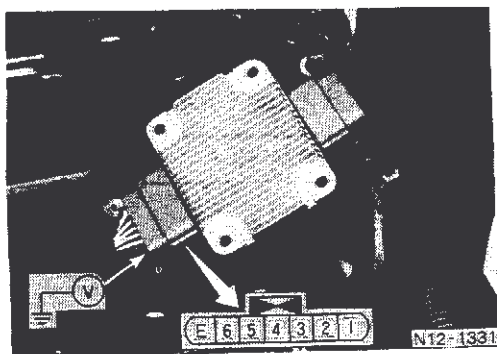

(3) Ignition primary voltage signal inspection

- Measure the primary voltage of coil side connector of power transistor.

Engine	RB26DETT	
Measurement location	Voltage between power transistor IGN coil side terminals 1, 2, 3, 4, 5, 6, and ground	Voltage between IGN coil side terminal E and ground.
Condition		
Cranking	Approx. 10V	0V
Idling	Approx. 14V	0V
2,500 rpm	Approx. 14V	0V

B3 ECCS (Electronically Concentrated Engine Control System)

5. Actuator System Inspection (Cont'd)

(4) Harness continuity inspection

- Disconnect the connectors on the input side of the ECCS control unit and power transistor unit, and measure the resistance between the following terminals.

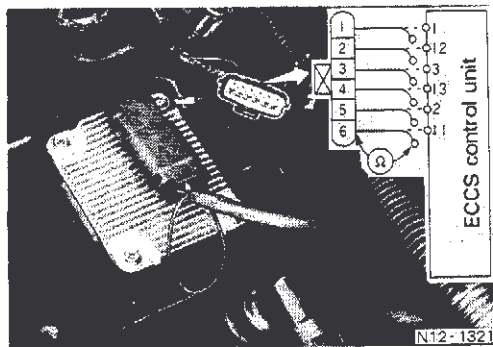

Measurement location		Engine
		RB26DETT
ECCS C/U harness	Power transistor unit harness (6 polarity terminal)	
Between terminal 1	and terminal 1.	0Ω
Between terminal 12	and terminal 2.	
Between terminal 3	and terminal 3.	
Between terminal 13	and terminal 4.	
Between terminal 2	and terminal 5.	
Between terminal 11	and terminal 6.	

B3 ECCS (Electronically Concentrated Engine Control System)

5. Actuator System Inspection (Cont'd)

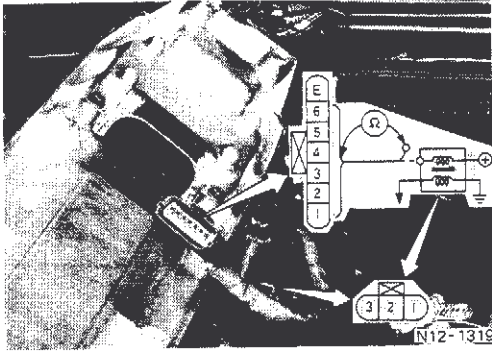

- Disconnect the connector from the power transistor unit output side and ignition coil, and measure the resistance between the following terminals.

Measurement location		Engine	RB26DETT
Power transistor unit harness (7 polarity terminal side)	Ignition coil connector harness (terminal 1)		
Terminal 1	to	No. 1 cylinder	0Ω
Terminal 2	to	No. 2 cylinder	
Terminal 3	to	No. 3 cylinder	
Terminal 4	to	No. 4 cylinder	
Terminal 5	to	No. 5 cylinder	
Terminal 6	to	No. 6 cylinder	

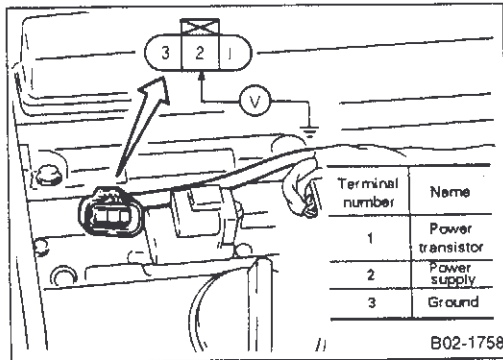

- Disconnect ignition coil connector and measure the voltage between the following terminals.

Measurement location		Engine	RB26DETT
Condition			Between ignition coil connector harness terminal (2) and ground
Ignition switch ON			Battery voltage

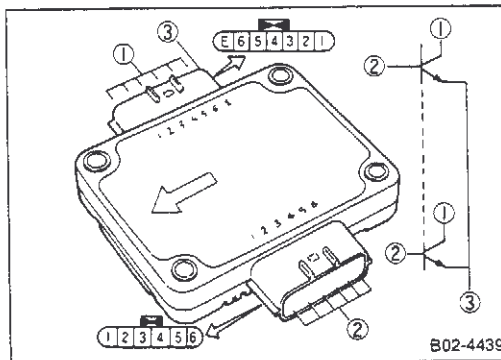

(5) Power transistor inspection

- Check the resistance value between all power transistor terminals with an analog circuit tester probe by changing the positive ⊕ and negative ⊖ poles.

Inspection terminals and values		
① - ③	⊕ - ⊖	Not 0 or ∞Ω < ⊖ - ⊕ ∞Ω
② - ③	⊕ - ⊖	Not 0 or ∞Ω = ⊖ - ⊕ 0 or ∞Ω
① - ②	⊕ - ⊖	Not 0 or ∞Ω < ⊖ - ⊕ ∞Ω

(6) Ignition coil inspection

- Measure primary coil resistance value.

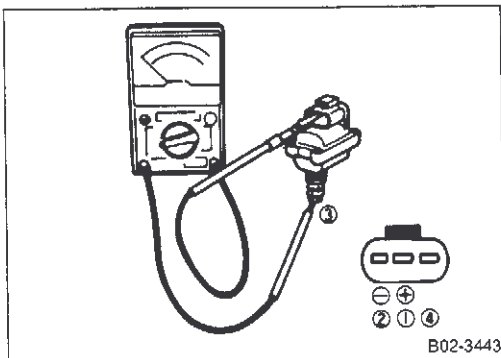

Measurement location		Engine	RB26DETT
Primary coil resistance value (① - ②)	(Ω)		0.6 - 0.9
(Reference): Secondary coil resistance value (③ - ④): ∞Ω			

B3 ECCS (Electronically Concentrated Engine Control System)

5. Actuator System Inspection (Cont'd)

5-4 IDLE SPEED CONTROL SYSTEM INSPECTION

[Control circuit]

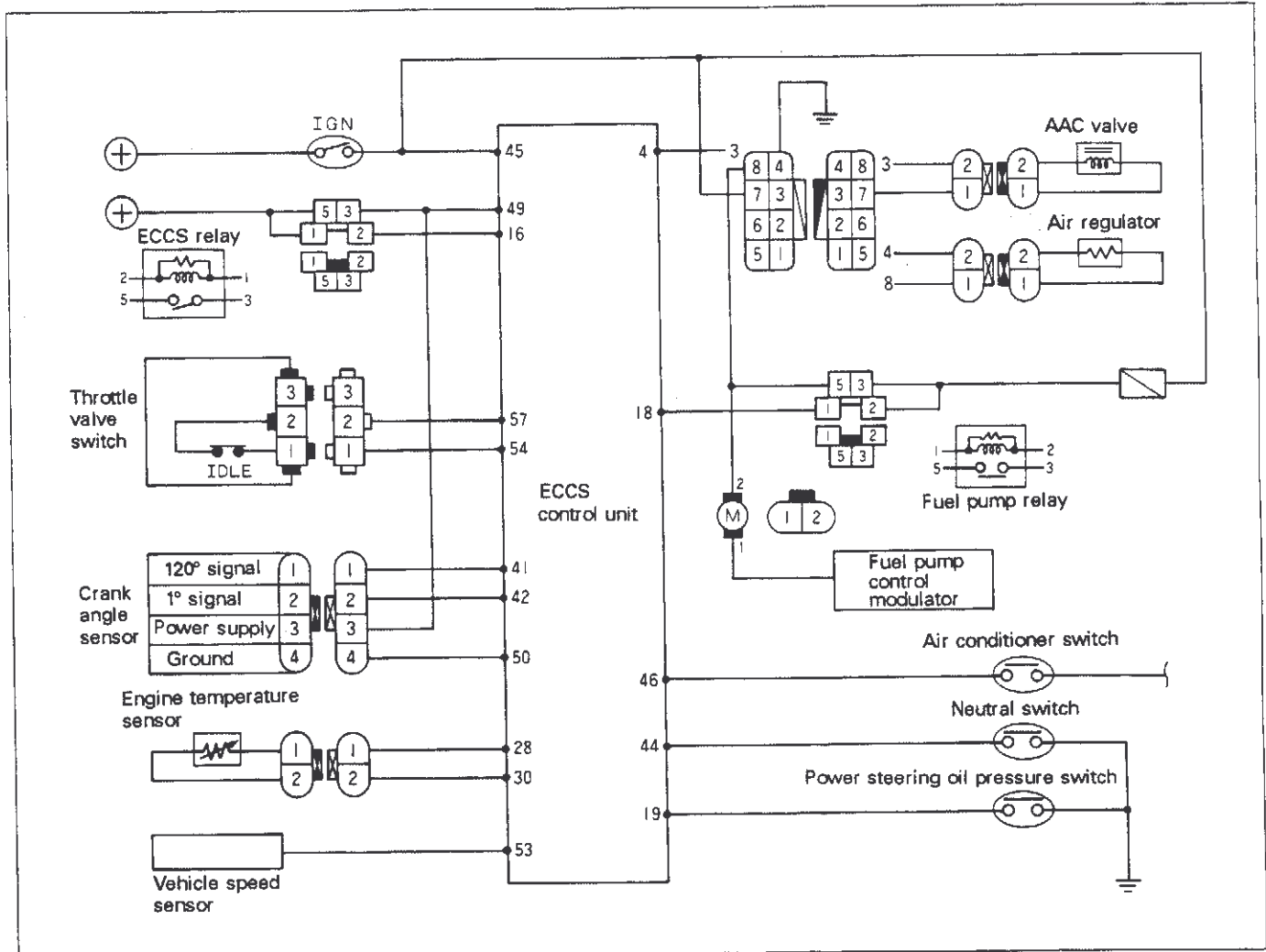

[Control description]

Input signal	Terminal number	Control description
Crank angle sensor 1° signal	42, 52	<ul style="list-style-type: none"> ● Engine speed is read and feedback control is performed for the speed value.
Engine temperature sensor	28	<ul style="list-style-type: none"> ● The target engine speed is changed according to cooling water temperature.
Throttle valve SW (idle connection point)	54	<ul style="list-style-type: none"> ● Activated when throttle sensor damage occurs. (Idle judgment backup.)
Throttle sensor	38	<ul style="list-style-type: none"> ● Deceleration fuel cut ● Flow correction at acceleration or deceleration ● Interruption injection ● Idle judgment ● Deceleration fuel cut according to ON signal. ● Acceleration increase when ON goes to OFF.
Vehicle speed sensor	53	<ul style="list-style-type: none"> ● Idle control starts at vehicle speed under 8 km/h (5 MPH).
Air conditioning switch	46	<ul style="list-style-type: none"> ● After engine warms up, increases idle when air conditioning is turned ON.
Neutral switch	44	<ul style="list-style-type: none"> ● Starts idle control in neutral position.

B3 ECCS (Electronically Concentrated Engine Control System)

5. Actuator System Inspection (Cont'd)

Input signal	Terminal number	Control description
Power steering oil pressure switch	19	● Increases idle speed when power steering fluid pressure is too high.
Battery voltage	49	● When battery voltage is low (less than 12V), idle speed is increased.

B3 ECCS (Electronically Concentrated Engine Control System)

5. Actuator System Inspection (Cont'd)

Idle speed control system trouble diagnosis flowchart

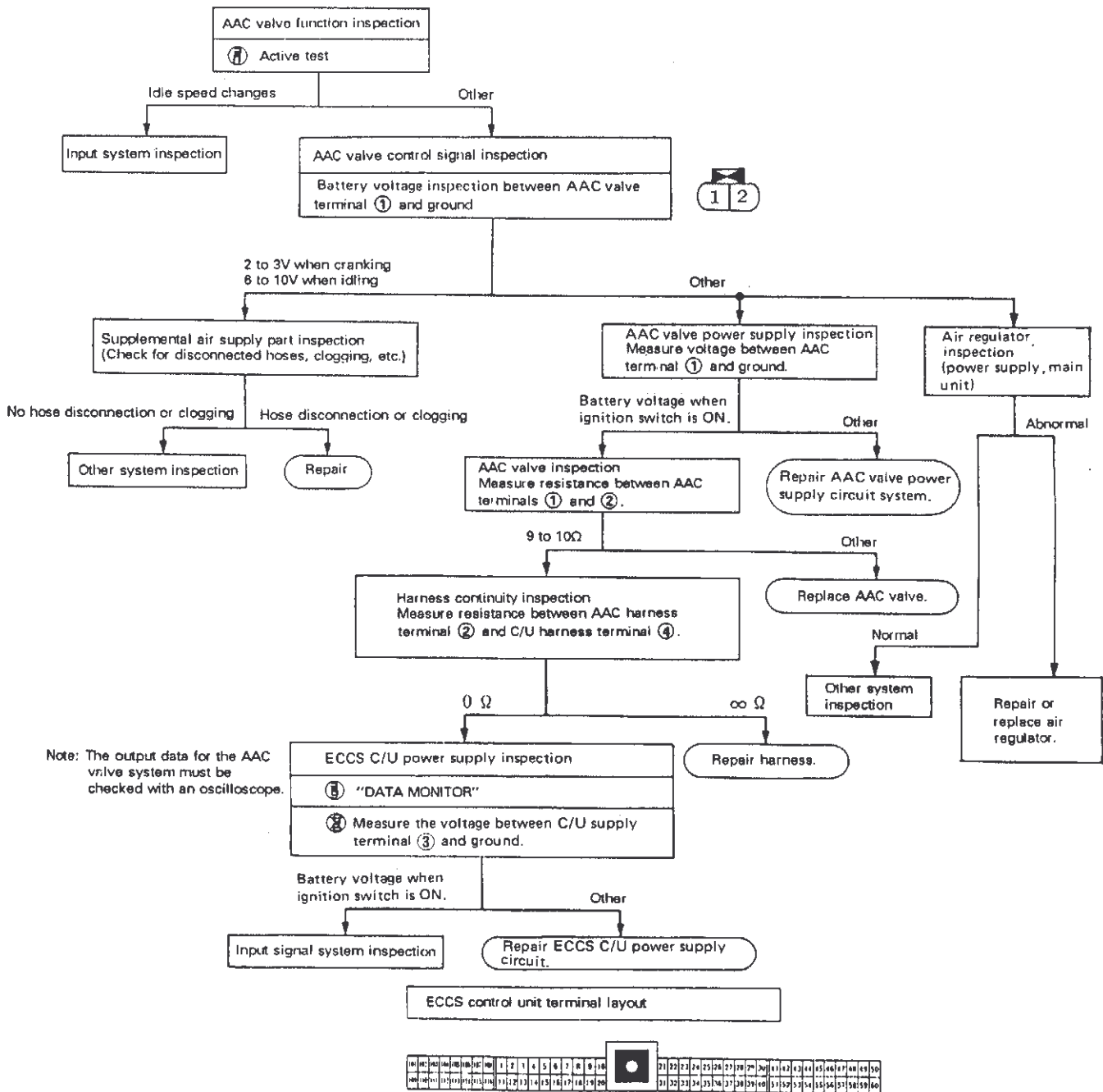

Note: The output data for the AAC valve system must be checked with an oscilloscope.

B3 ECCS (Electronically Concentrated Engine Control System)

5. Actuator System Inspection (Cont'd)

(1) AAC valve control signal inspection

- When ECCS control unit connector is connected, measure the voltage between the following terminals and ground.

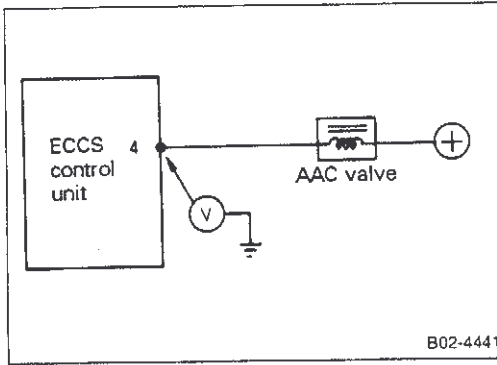

Engine		RB26DETT
Measurement location		Between ECCS C/U terminal (4) and ground
Condition		
Ignition switch is ON		Battery voltage
Cranking engine		2 - 3V
Idling	When cold	6 - 7V
	After warm-up	8 - 10V

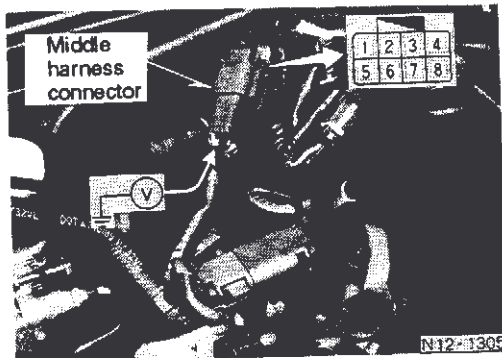
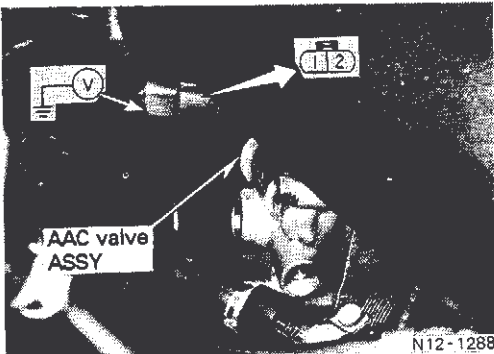

- Measure the voltage between the AAC valve connector terminal (2) and middle harness connector terminal (3) and ground.

(2) AAC valve function inspection



- Use "AAC VALVE OPENING" item of "ACTIVE TEST" mode to set an optional angle.
- Check that idle speed changes corresponding to setting value at this time.

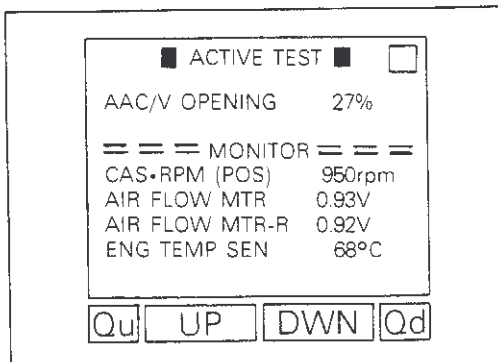

(3) AAC valve power inspection

- Disconnect AAC valve connector and measure voltage between the following terminals and ground.

Engine		RB26DETT
Measurement location		Between AAC valve connector harness terminal (1) and ground.
Condition		
When ignition switch is ON.		Battery voltage



B3 ECCS (Electronically Concentrated Engine Control System)

5. Actuator System Inspection (Cont'd)

- Measure the voltage between the middle harness connector terminal (7) and the ground.

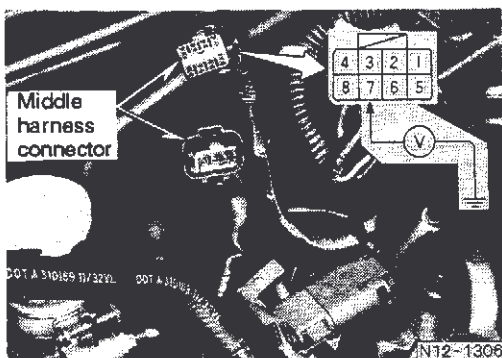

(4) Harness continuity inspection

- Disconnect the connector from the ECCS control unit and AAC valve and measure the resistance between the following terminals.

Engine	RB26DETT	
Measurement location	Between ECCS control unit harness terminal (4) and AAC valve harness terminal (2)	0Ω

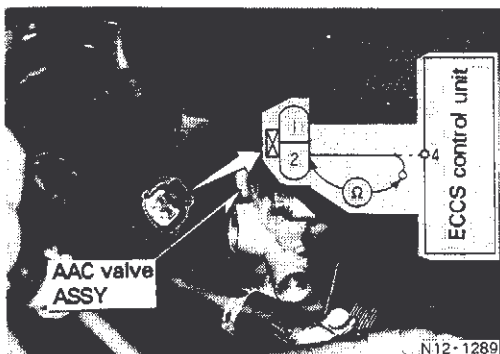

Engine	RB26DETT	
Measurement location	Between Middle connector AAC valve terminal (3) and AAC valve harness terminal (2)	0Ω

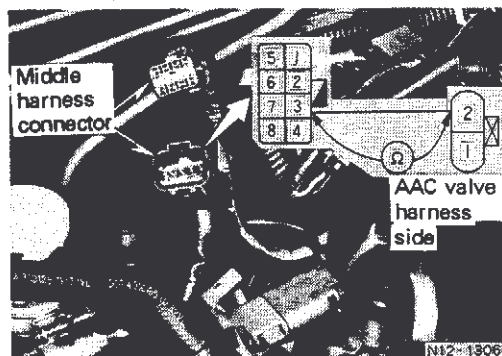

(5) AAC valve inspection

- Disconnect the AAC valve connector and measure the resistance between the following AAC valve terminals.

Engine	RB26DETT
Measurement location	Between AAC valve terminals (1) and (2)
	9 - 10Ω



- Measurement can also be performed at middle connector terminals.

Engine	RB26DETT
Measurement location	Between AAC valve terminals (3) and (7)
	9 - 10Ω

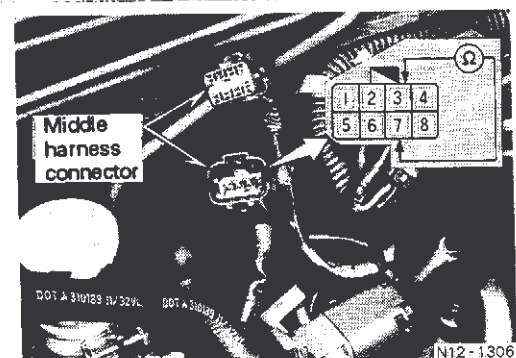

B3 ECCS (Electronically Concentrated Engine Control System)

5. Actuator System Inspection (Cont'd)

(6) Air regulator power supply inspection

- Measure the voltage between the following terminals and ground when the air regulator middle harness is connected.

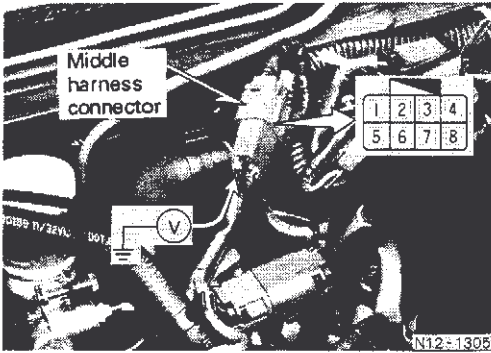

Engine	RB26DETT
Measurement location	Between middle harness connector terminal (8) and ground
Condition	Ignition switch ON
	5-sec interval battery voltage
Cranking	Approx. 1V
Idling	Approx. 1V

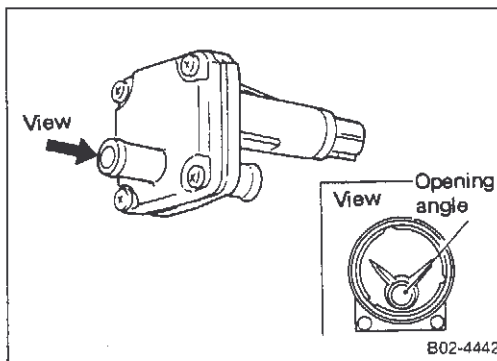

(7) Air regulator inspection

- ① Shutter opening angle inspection (static characteristic)
 - Visually inspect the shutter angle.

Ambient temperature °C (°F)	Shutter opening angle
-20 (-4) max.	Fully open
20 (68)	Half-open
60 (140) min.	Fully closed

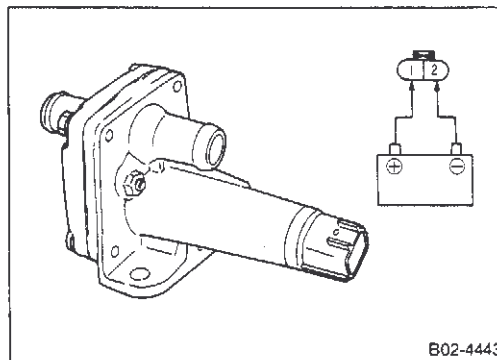

- ② Inspection (dynamic characteristic)
 - Apply current from the battery to the terminals and check changes in shutter opening angle.

The shutter must gradually close fully within 7 minutes.
[Ambient temperature approx. 20°C (68°F)]

(Reference) Heater resistance value: 75Ω [20°C (68°F)]

B3 ECCS (Electronically Concentrated Engine Control System)

5. Actuator System Inspection (Cont'd)

5-5 WASTEGATE VALVE CONTROL SYSTEM INSPECTION

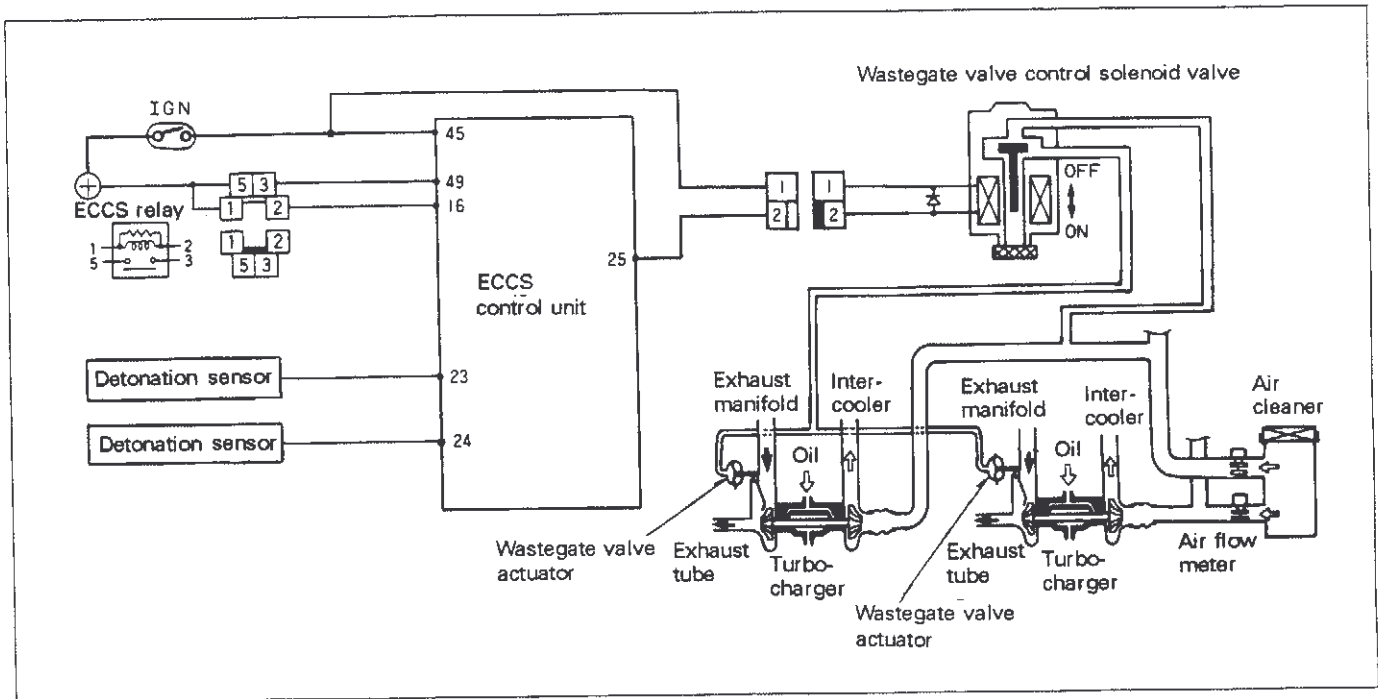

Wastegate valve control system trouble diagnosis flowchart

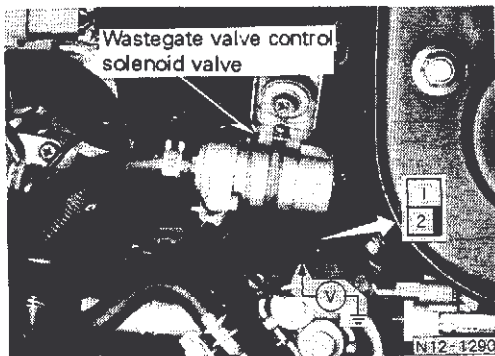
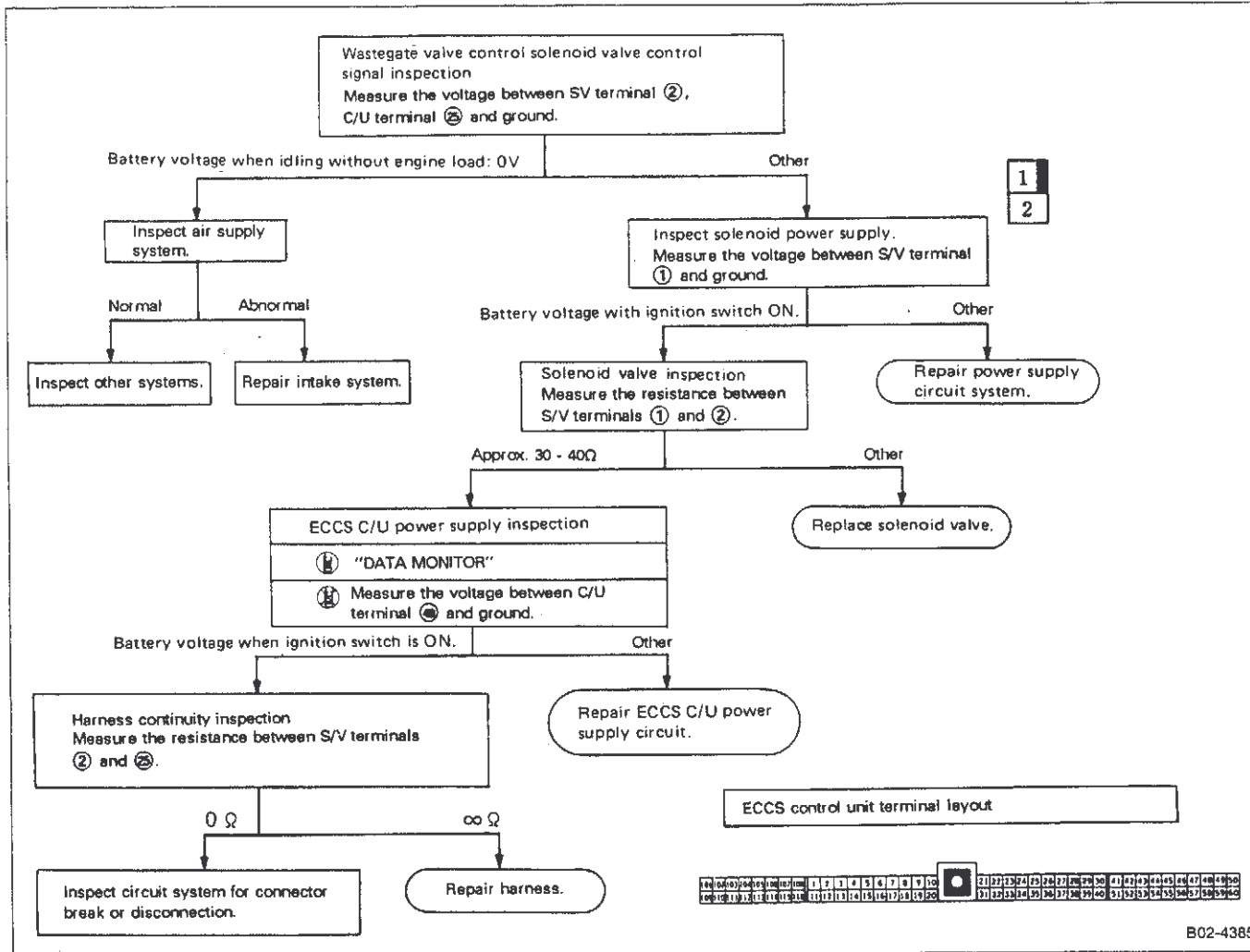

(1) Wastegate valve control solenoid valve control signal inspection

- When wastegate valve control solenoid valve connectors are connected, measure the voltage between the following terminals and ground.
- When ECCS control unit connectors are connected, measure the voltage between the following terminals and ground.

Engine	RB26DETT
Measurement location	<ul style="list-style-type: none"> • Between solenoid valve terminal (2) and ground • Between ECCS C/U terminal (25) and ground
Condition	
Idling	Battery voltage
With accelerator pedal depressed	Approx. 0V

B3 ECCS (Electronically Concentrated Engine Control System)

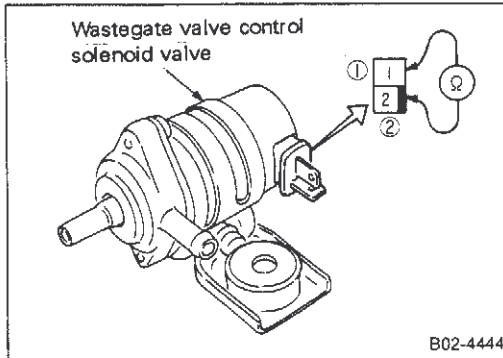
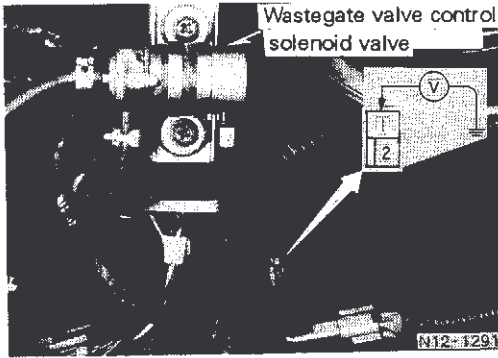

5. Actuator System Inspection (Cont'd)

(2) Wastegate valve control solenoid valve power supply inspection

- Remove the wastegate valve control solenoid valve connector and measure the voltage between the following terminals and the ground.

Engine	RB26DETT
Measurement location	Between solenoid valve harness terminal (1) and ground
Condition	Ignition switch ON
Ignition switch ON	Battery voltage

(3) Wastegate valve control solenoid valve inspection

- Disconnect the wastegate valve control solenoid valve connector and measure the resistance between the following terminals.

Engine	RB26DETT
Measurement location	Between solenoid side terminals (1) and (2)
Between solenoid side terminals (1) and (2)	30 - 40Ω

(4) ECCS control unit power supply inspection

- Refer to the fuel pump system section.

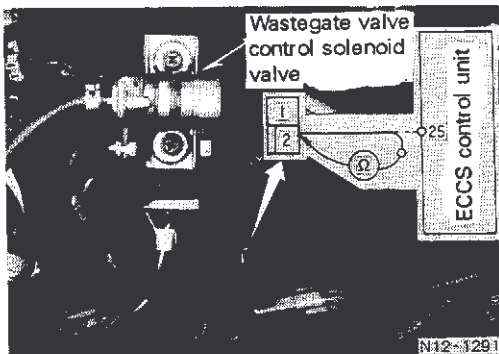

(5) Harness continuity inspection

- Disconnect the connectors from the wastegate valve control solenoid valve and ECCS control unit and measure the resistance between the following terminals.

Engine	RB26DETT
Measurement terminal	Between ECCS C/U harness terminal (25) and solenoid valve harness terminal (2)
Between ECCS C/U harness terminal (25) and solenoid valve harness terminal (2)	0Ω

5-6 SUB ELECTRICAL FAN SYSTEM INSPECTION

Refer to item B6, 6.

B3 ECCS (Electronically Concentrated Engine Control System)

6. Sensor System Inspection

Use a circuit tester, CONSULT electrical system diagnosis tester and oscilloscope to test the sensor system. Refer to section 1, 1-1, (6) for an explanation of the measurement equipment operation procedures. Refer to section 5. for preparation.

6-1 CRANK ANGLE SENSOR SYSTEM INSPECTION

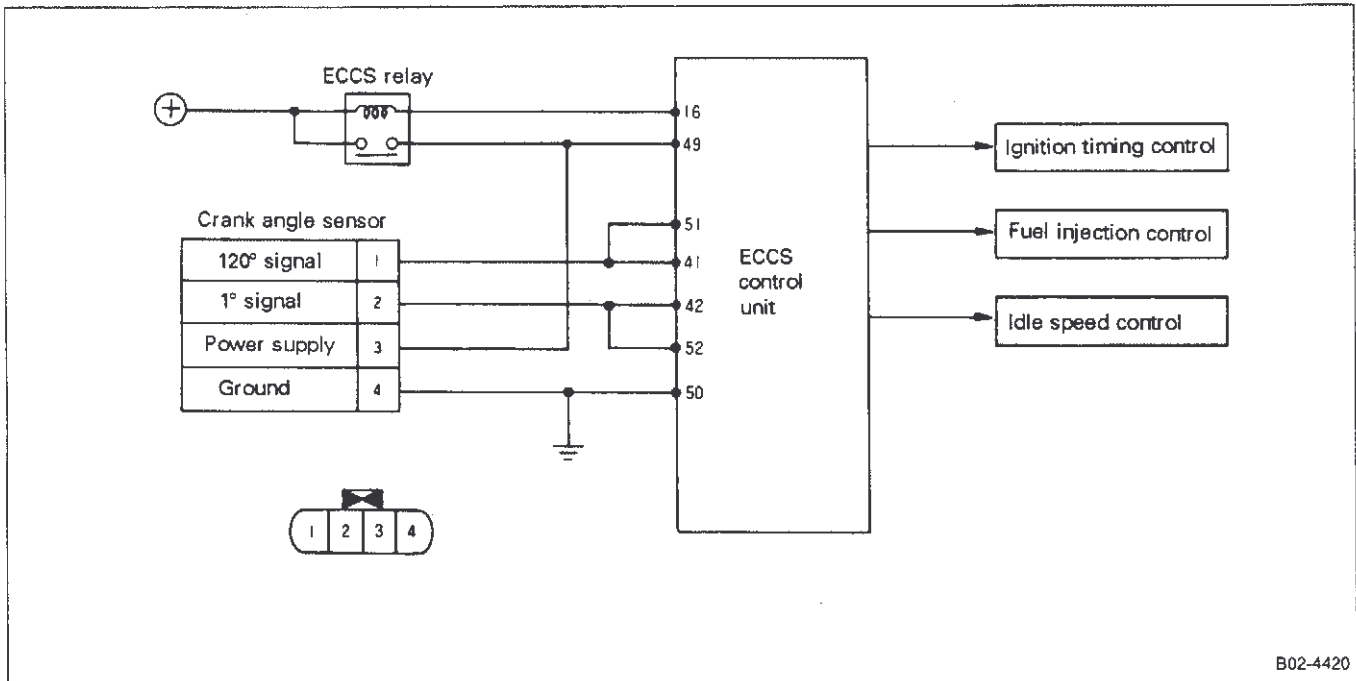

B3 ECCS (Electronically Concentrated Engine Control System)

6. Sensor System Inspection (Cont'd)

Crank angle sensor system trouble diagnosis flowchart

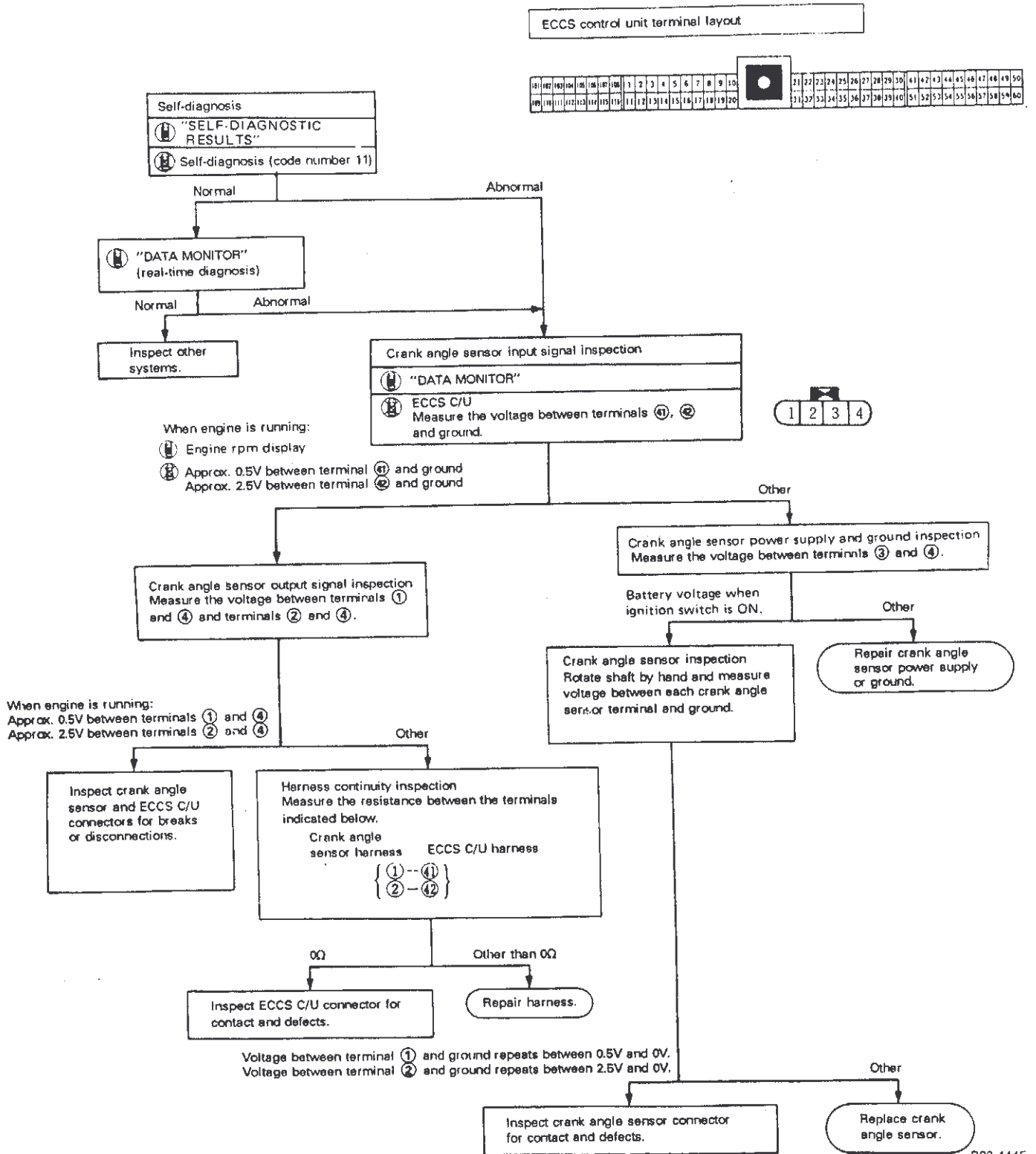

B02-4445

Note: For crank angle sensor system inspection, use CONSULT and oscilloscope to check output waveform.

B3 ECCS (Electronically Concentrated Engine Control System)

6. Sensor System Inspection (Cont'd)

(1) Self-diagnosis

- Normally in a self-diagnosis operation, when "CODE 11" or "FAULTY SYSTEM NAME" (when using CONSULT) is displayed if the 1° or 120° signal is not input within a fixed period of time. When this occurs, examine the following items carefully.

- When the malfunction reoccurs, use the real-time diagnosis (CONSULT "DATA MONITOR" mode) or oscilloscope to detect disconnections.
- When an abnormality is detected, consider these locations in the following sequence because there may be other malfunctions besides the crank angle sensor.

ECCS harness (faulty contact) → crank angle sensor → ECCS control unit

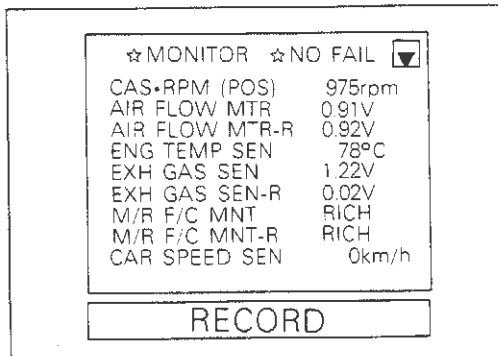

(2) Input signal inspection

- Use the "CAS-RPM(POS)" item of the "DATA MONITOR" mode to determine engine speed.

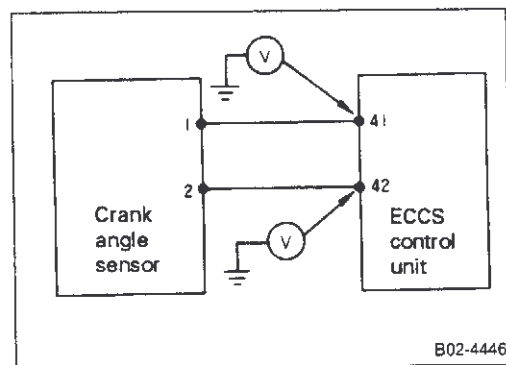

- Measure the voltage between the following terminals and ground with ECCS control unit harness connected.

Engine	RB26DETT	
Measurement location	Between ECCS C/U terminal (41) and ground (120° signal)	Between ECCS C/U terminal (42) and ground (1° signal)
Condition		
Ignition switch ON	0V or approx. 5V	←
Cranking	Approx. 0.5V	2 - 3V
Idling	0.3 - 0.7V	2 - 3V

CAUTION:

The voltages in this chart are average voltage values of the pulse waveform measured by a circuit tester and these are the reference values. The waveform must be checked by an oscilloscope.

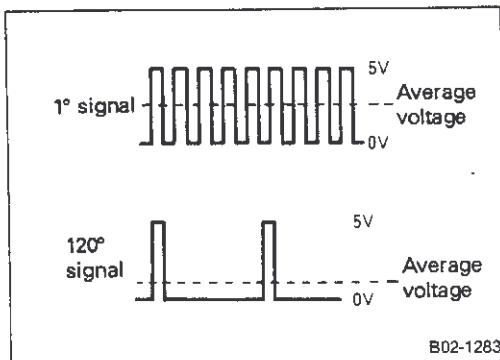

B3 ECCS (Electronically Concentrated Engine Control System)

6. Sensor System Inspection (Cont'd)

(3) Sensor output signal inspection

- Connect crank angle sensor connector, insert voltage measurement probe behind rear of connector and measure the voltages between following terminals.

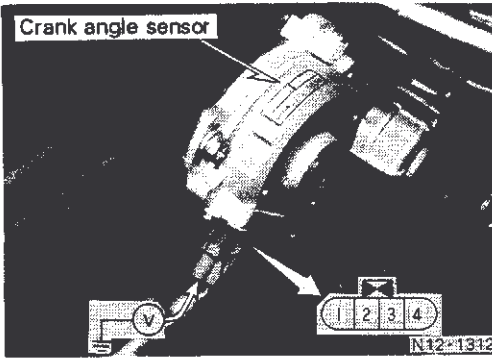

Engine	RB26DETT		
Measurement location	Between crank angle sensor terminal (2) and ground (1° signal)	Between crank angle sensor terminal (1) and ground (120° signal)	Between crank angle sensor terminal (3) and ground (power)
Condition			
Ignition switch ON	0V or approx. 5V	←	Battery voltage
Cranking engine	2 - 3V	Approx. 0.5V	Battery voltage
Idling	2 - 3V	0.3 - 0.7V	Battery voltage

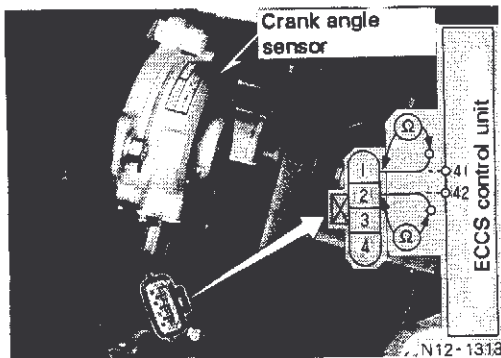

(4) Harness continuity inspection

- Disconnect connectors of ECCS control unit and crank angle sensor. Measure the resistance between the following terminals.

Engine	RB26DETT		
Measurement location	ECCS C/U harness	Crank angle sensor harness	0 Ω
	Terminals (41) - (1) (42) - (2)		

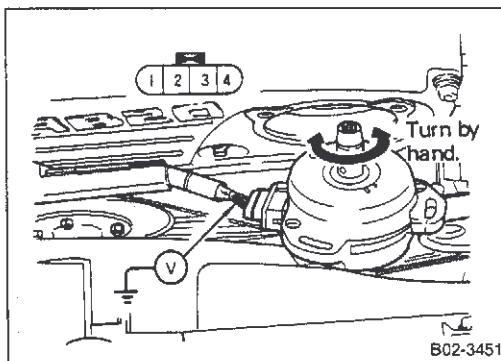

(5) Crank angle sensor inspection

- Disconnect crank angle sensor from engine, turn shaft by hand and measure connector voltage.

Engine	RB26DETT			
Measurement location	Between crank angle sensor terminal (2) and ground (1° signal)	Between crank angle sensor terminal (1) and ground (120° signal)	Between crank angle sensor terminal (3) and ground (power supply)	Between crank angle sensor terminal (4) and ground (ground)
Condition				
Ignition switch ON	0V or approx. 5V	←	Battery voltage	0V

CAUTION:

To prevent injector from operating, remove fuse or connector before inspection. When an apparent abnormality is detected by self-diagnosis according to shaft rotation, be careful because it may not be an actual abnormality in this case.

B3 ECCS (Electronically Concentrated Engine Control System)

6. Sensor System Inspection (Cont'd)

6-2 AIR FLOW METER SYSTEM INSPECTION

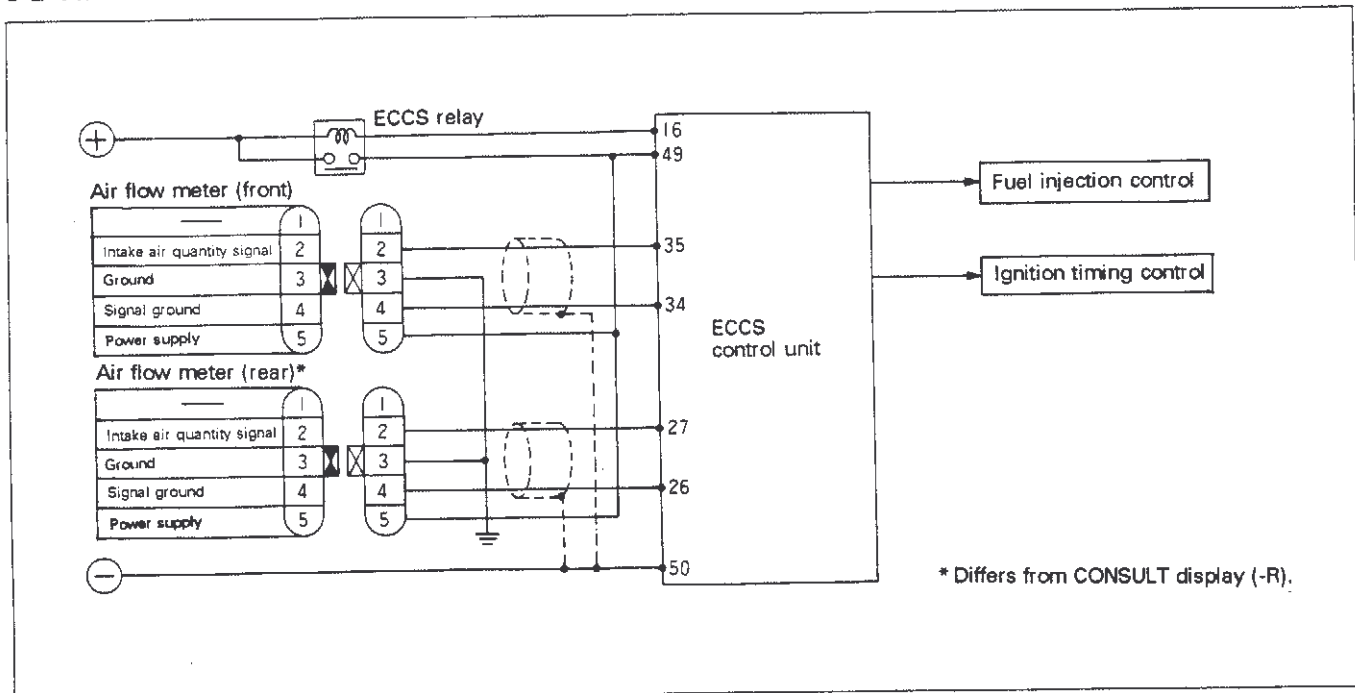

Cylinder air flow meter, CONSULT (data monitor) display items

Cylinder No.	Air flow meter	ECCS C/U terminal number	CONSULT (data monitor) display
No. 1, 2, 3 cyl.	AFM (Front)	ECCS C/U ③⑤	AIR FLOW METER-R
No. 4, 5, 6 cyl.	AFM (Rear)	ECCS C/U ②⑦	AIR FLOW METER

B3 ECCS (Electronically Concentrated Engine Control System)

6. Sensor System Inspection (Cont'd)

Air flow meter system trouble diagnosis flowchart

ECCS control unit terminal layout

11	12	13	14	15	16	17	18	19	20	21	22	23	24	25	26	27	28	29	30	31	32	33	34	35	36	37	38	39	40	41	42	43	44	45	46	47	48	49	50
41	42	43	44	45	46	47	48	49	50	51	52	53	54	55	56	57	58	59	60																				

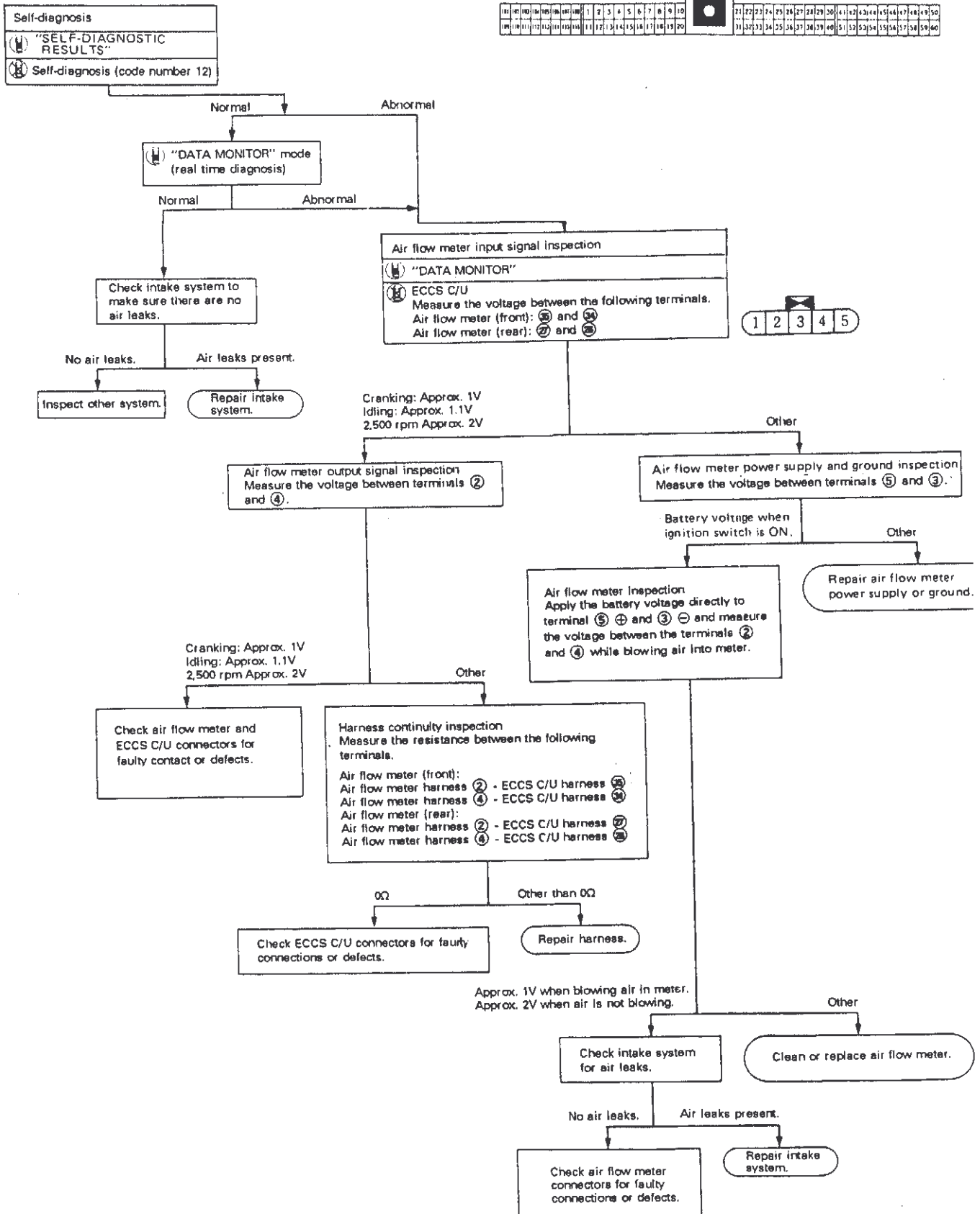

B3 ECCS (Electronically Concentrated Engine Control System)

6. Sensor System Inspection (Cont'd)

(1) Self-diagnosis

- When the "CODE No. 12" or "FAULTY SYSTEM - AIR FLOW METER" (when CONSULT is used) are normally displayed in self-diagnosis, the intake air quantity signal voltage is abnormally high or low, and a disconnection or short-circuit in the signal system should be considered.
- When the malfunction occurs again, use real-time diagnosis (CONSULT "DATA MONITOR" mode) or oscilloscope to detect instantaneous breaks.
- When an abnormality is detected, consider these locations in the following sequence because there may be other malfunctions besides the air flow sensor.

When intake air quantity is low: ECCS harness (faulty contact) → air flow meter → ECCS control unit → intake system (not airtight)

When intake air quantity is high: ECCS harness (faulty contact) → intake system (not airtight), faulty wastegate valve control, air flow meter → ECCS control unit

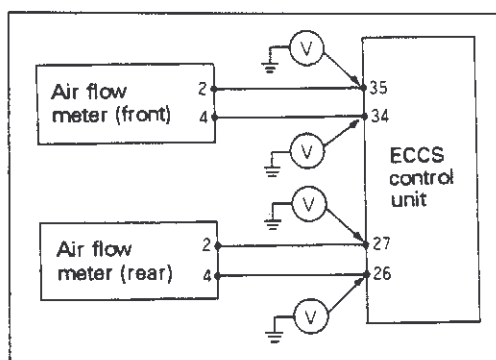
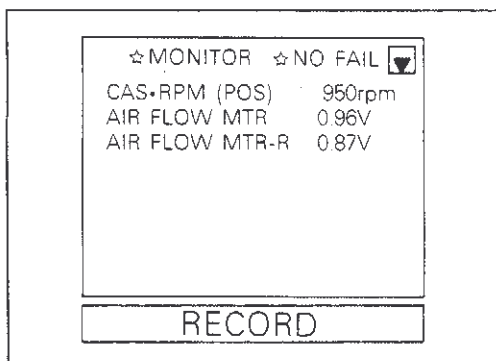

(2) Input signal inspection

- Use "AIR FLOW METER" and "AIR FLOW METER (R)" in the "DATA MONITOR" mode to check the following items.

Condition \ Item	Air flow meter (F)	Air flow meter (R)
Ignition switch ON	Approx. 0.3V	←
Idling	Approx. 1.1V	←
2,500 rpm	1.5 - 2.0	←

- Measure the voltage between the following terminals with the ECCS control unit harness connected.

Measurement location \ Condition	Air flow meter (F)		Air flow meter (R)	
	ECCS C/U terminal (35) and ground (intake air quantity signal)	ECCS C/U terminal (34) and ground (ground signal)	ECCS C/U terminal (27) and ground (intake air quantity signal)	ECCS C/U terminal (26) and ground (ground signal)
Ignition switch ON	Approx. 0.3V	0V	Approx. 0.3V	0V
Cranking engine	Approx. 1V	0V	Approx. 1V	0V
Idling	Approx. 1.1V	0V	Approx. 1.1V	0V

B3 ECCS (Electronically Concentrated Engine Control System)

6. Sensor System Inspection (Cont'd)

(3) Air flow meter output signal inspection

- Measure the voltage between the following terminals with the air flow meter connectors connected.

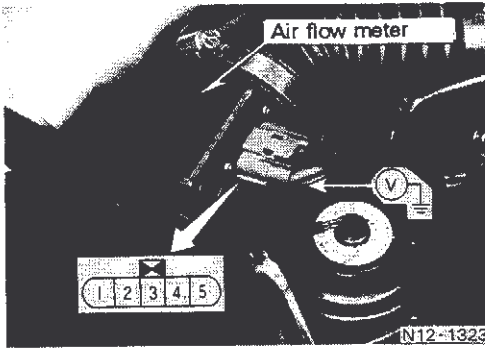

Item	Air flow meter (F)		Air flow meter (R)			
	Measurement location	Condition	Air flow meter terminal (2) and ground (intake air quantity signal)	Air flow meter terminal (4) and ground (ground signal)	Air flow meter terminal (2) and ground (intake air quantity signal)	Air flow meter terminal (4) and ground (ground signal)
Ignition switch ON	Approx. 0.3V	0V	Approx. 0.3V	0V	Approx. 0.3V	0V
Cranking engine	Approx. 1V	0V	Approx. 1V	0V	Approx. 1V	0V
Idling	Approx. 1.1V	0V	Approx. 1.1V	0V	Approx. 1.1V	0V

(4) Air flow meter power supply inspection

- Measure the voltage between the following terminals and the ground with the air flow meter harness connected.

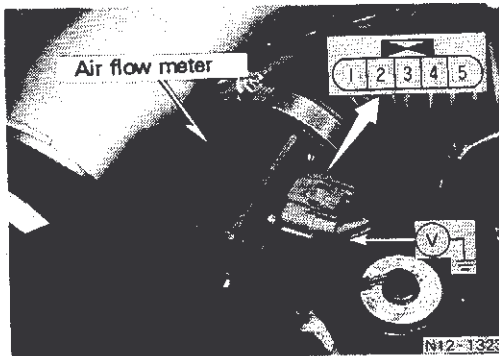

Condition	Engine	RB26DETT
	Measurement location	Between air flow meter terminal (5) and ground
Ignition switch ON and engine running	Battery voltage	

(5) Harness continuity inspection

- Disconnect the ECCS control unit and air flow meter connectors and measure the resistance between the following terminals.

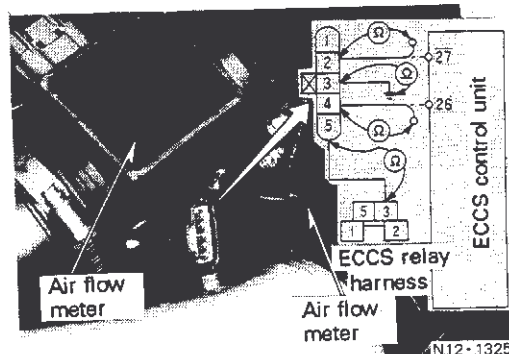
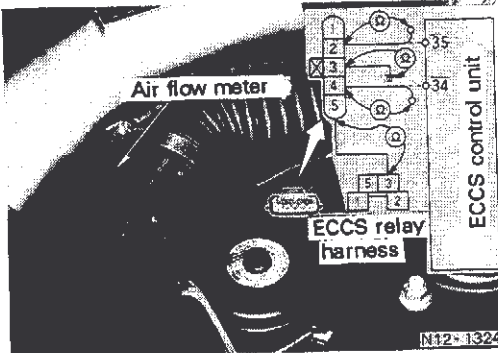

Measurement location	Air flow meter (Front)		Air flow meter (Rear)		0Ω	0Ω
	Air flow meter harness	ECCS C/U harness	Air flow meter harness	ECCS C/U harness		
terminal (2) to terminal (35)			terminal (2) to terminal (27)			
terminal (4) to terminal (34)			terminal (4) to terminal (26)			
terminal (3) to body ground			terminal (3) to body ground			
terminal (5) to ECCS relay harness terminal (3)			terminal (5) to ECCS relay harness terminal (3)			

B3 ECCS (Electronically Concentrated Engine Control System)

6. Sensor System Inspection (Cont'd)

(6) Air flow meter inspection

- Apply the battery voltage directly to terminal (5) ⊕ and (3) ⊖ and measure the voltage change between the terminals (2) and (4) while blowing air on hot wire.

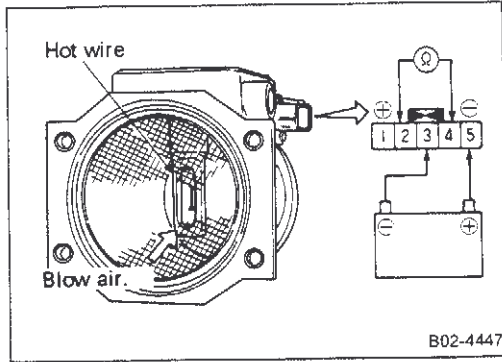

Condition	Engine	RB26DETT
No air blowing		Approx. 0.8V
Blow air.		Approx. 2V

B3 ECCS (Electronically Concentrated Engine Control System)

6. Sensor System Inspection (Cont'd)

6-3 THROTTLE VALVE SWITCH SYSTEM INSPECTION

* The throttle valve switch signal operates when the throttle sensor is faulty.

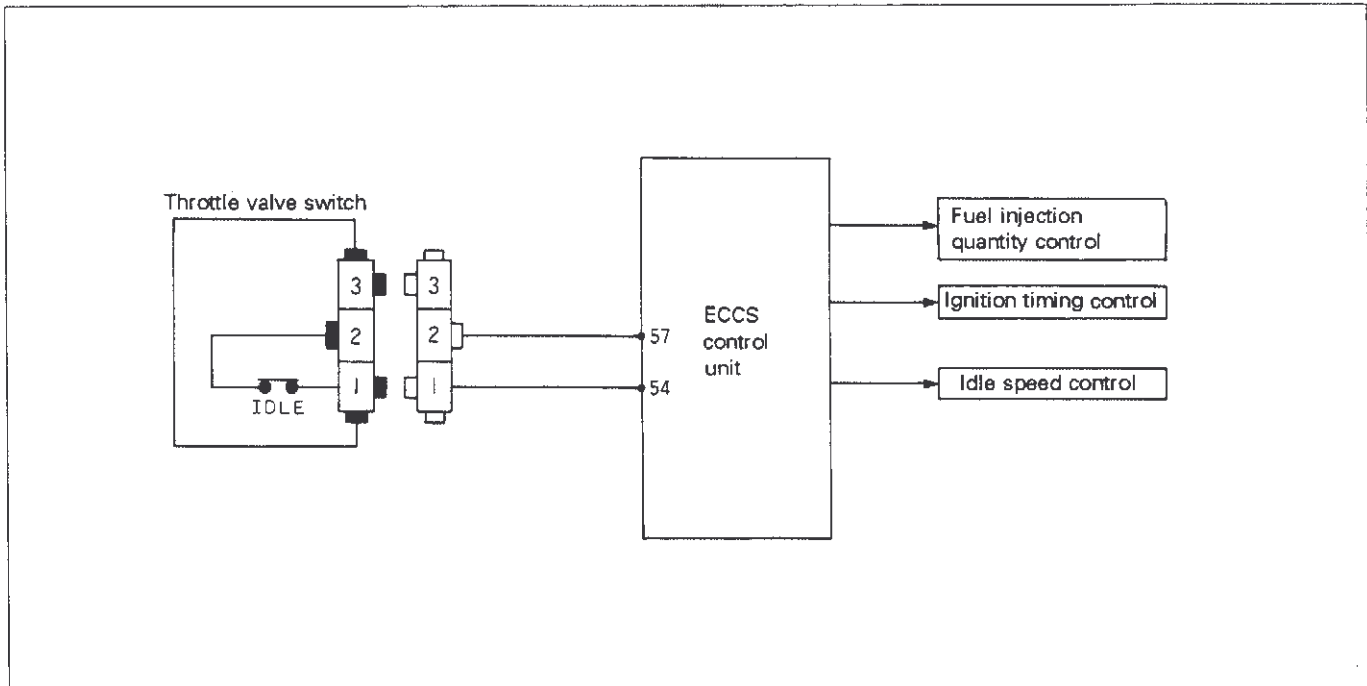

Throttle valve switch system trouble diagnosis flowchart

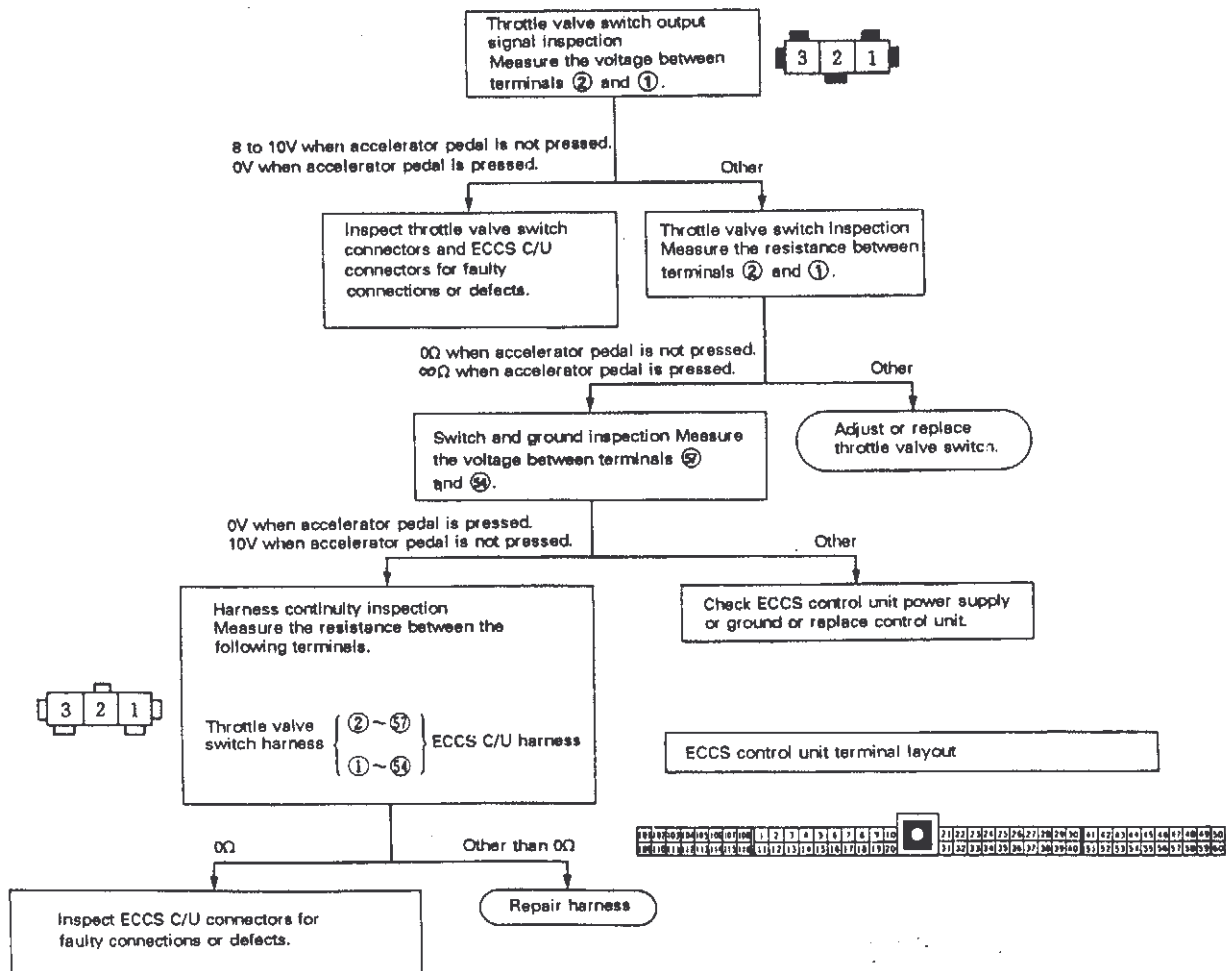

B3 ECCS (Electronically Concentrated Engine Control System)

6. Sensor System Inspection (Cont'd)

(1) Input/output signal inspection

- Measure the voltage between the following terminals and the ground with the ECCS control unit harness connected.
- Measure the voltage between the throttle valve switch connector terminal (2) and body ground.

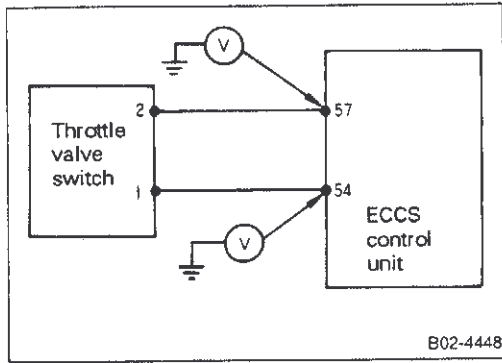

Engine		RB26DETT
Condition	Measurement location	Between ECCS control unit terminal (54) and ground (or throttle valve switch terminal (1) and ground)
	Ignition switch ON or engine running	Accelerator pedal is not pressed (idle contact ON) 8 - 10V Accelerator pedal is pressed (idle contact OFF) 0V
Cranking engine		Approx. 8V

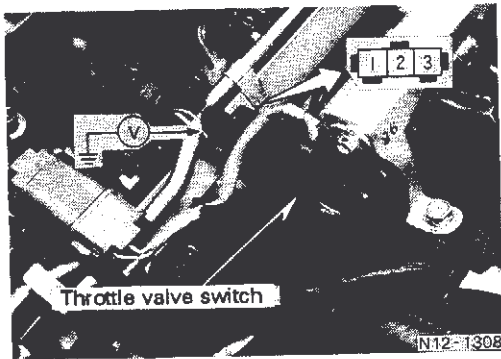

- Measure the voltage between the following terminals and the ground with the ECCS control unit harness connected.
- Measure the voltage between the throttle valve switch connector terminal (2) and body ground.

Engine		RB26DETT
Condition	Measurement location	Between ECCS control unit terminal (57) and ground (or throttle valve switch terminal (2) and ground)
	Ignition switch ON	8 - 10V

B3 ECCS (Electronically Concentrated Engine Control System)

6. Sensor System Inspection (Cont'd)

(2) Throttle valve switch inspection (idle contact point)

- Remove the throttle valve switch connector and measure the resistance between the following throttle valve switch terminals.

Engine	RB26DETT
Measurement location	Between throttle valve switch terminals (2) and (1)
Condition	
Accelerator pedal is not pressed (idle contact ON)	0Ω
Accelerator pedal is pressed (idle contact OFF)	∞ Ω

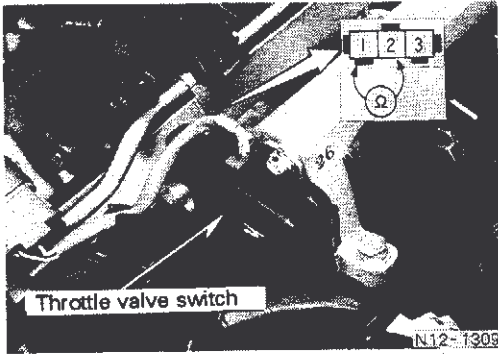

(3) Harness continuity inspection

- Remove the throttle valve switch and ECCS control unit connectors and measure the resistance between the following terminals.

Engine	RB26DETT		
Measurement location	ECCS C/U harness Terminal (54) Terminal (57)	Throttle valve switch harness to terminal (1) to terminal (2)	0Ω

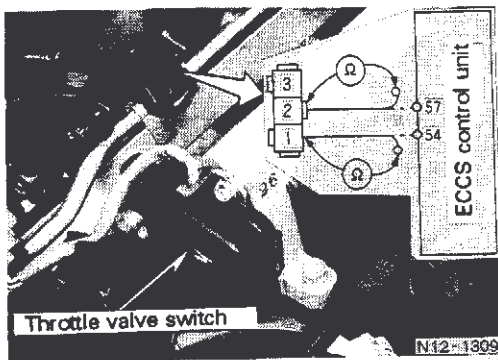

(4) Idle contact point (touch speed) inspection and adjustment

- Remove the AAC valve connector and inspect the unit when the AAC valve is fully opened.

Idle contact point tachometer speed (rpm)	1,200 ± 500
---	-------------

When the tachometer speed does not conform to the specified value, perform the adjustment as follows.

- Loosen the throttle valve switch tightening bolts (2).
- Remove the throttle valve switch connectors, place a test probe between throttle valve switch terminals (1) and (2) and measure the resistance.
- Press on the accelerator pedal and gradually release pedal to lower the engine speed. Rotate the throttle valve switch body and secure it in the position where the tachometer speed conforms to the specified value and the idle contact point is "ON" (the resistance between terminals (1) and (2) is 0Ω).
- Tighten the throttle valve switch tightening bolts.
- Make sure that the idle is ON observing by the tachometer speed as described above.
- Connect the throttle valve switch connectors.

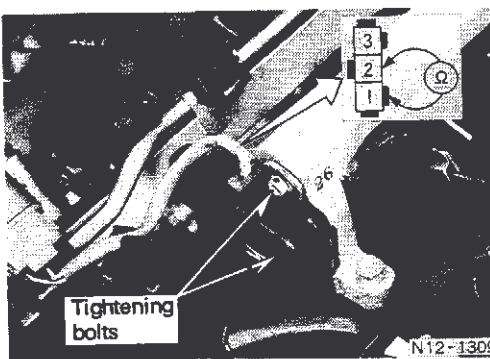

B3 ECCS (Electronically Concentrated Engine Control System)

6. Sensor System Inspection (Cont'd)

6-4 THROTTLE SENSOR SYSTEM INSPECTION

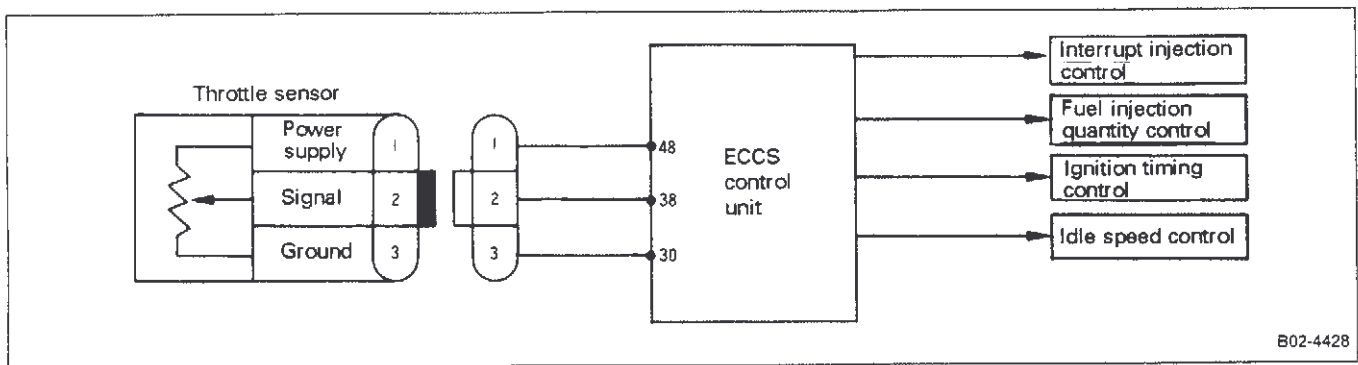

B3 ECCS (Electronically Concentrated Engine Control System)

6. Sensor System Inspection (Cont'd)

Throttle sensor system trouble diagnosis flowchart

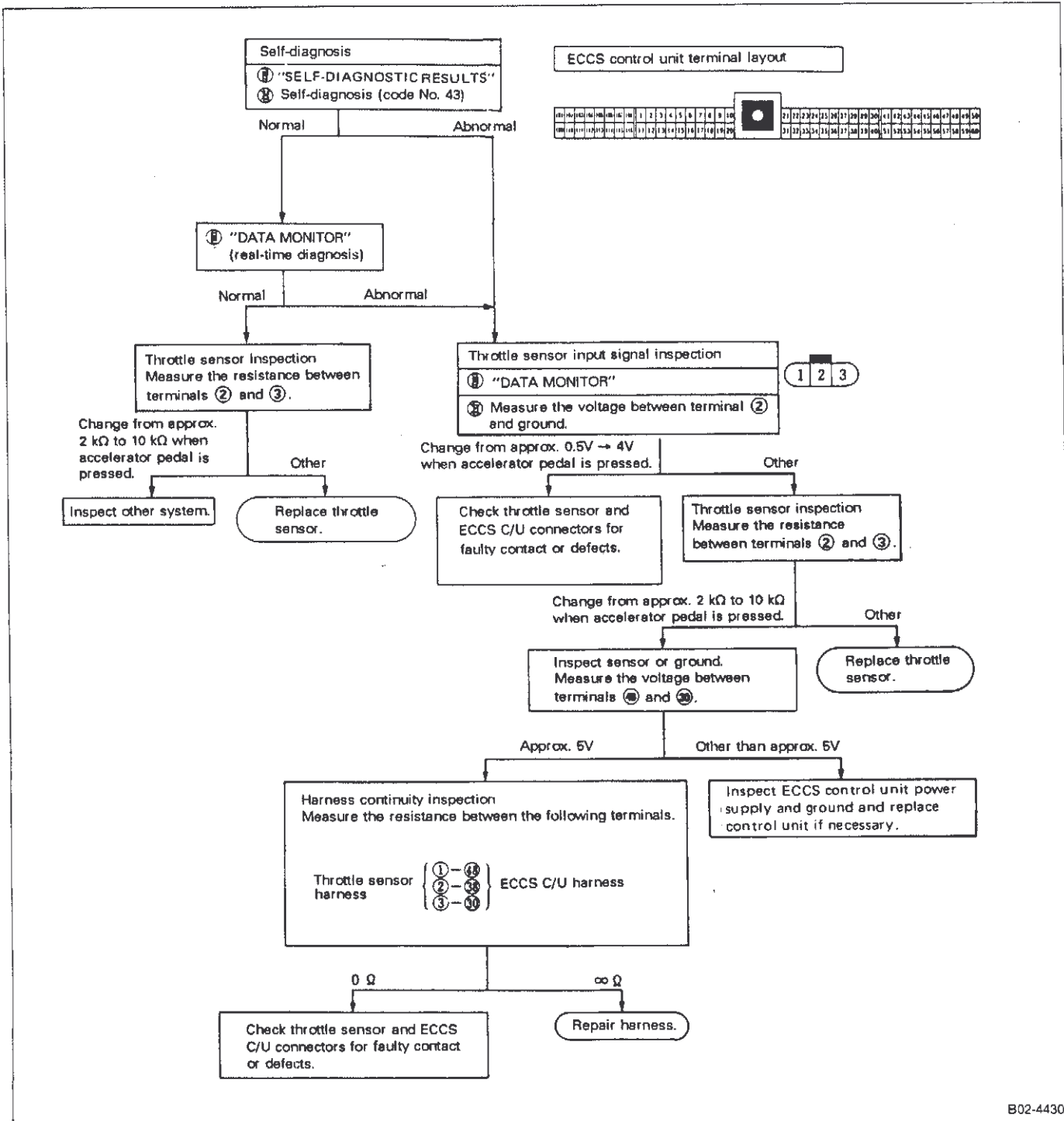

B02-4430

(1) Self-diagnosis

- There is a disconnection or short-circuit in the signal system when "CODE No. 43" is displayed in regular self-diagnosis (mode 2). If this occurs, check throttle sensor resistance, harness continuity, etc.
- If the problem reoccurs, use real-time diagnosis mode or an oscilloscope to check for instantaneous break in the signal.

B3 ECCS (Electronically Concentrated Engine Control System)

6. Sensor System Inspection (Cont'd)

(2) Input signal inspection

- Use the "THROTTLE SENSOR" setting of "DATA MONITOR" mode to check the following items.

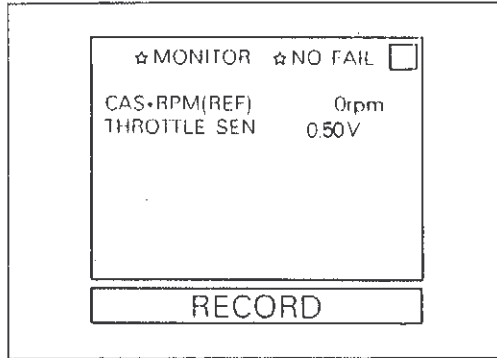

			Throttle sensor
Ignition switch ON	Accelerator pedal not pressed		Approx. 0.5V
	Accelerator pedal pressed	Half-way	0.5 - 4.0V
		Fully pressed	Approx. 4.0V

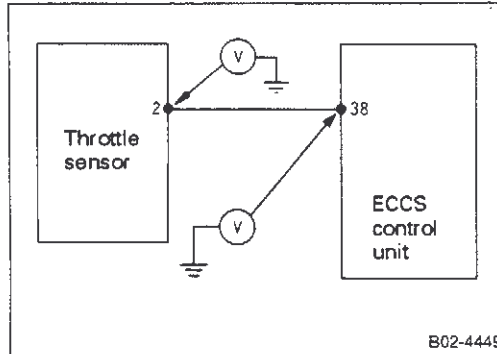

- Measure the voltage between the following terminals and ground with ECCS control unit harness connected.
- Measure the voltage between terminal (2) and ground with throttle sensor harness connected.

		Engine	RB26DETT
Condition	Measurement location		Between ECCS C/U terminal (38) and ground (or throttle sensor terminal (2) and ground)
	Ignition switch ON		Approx. 0.5V
	Cranking engine		Approx. 0.5V
Engine running	Accelerator pedal not pressed		Approx. 0.5V
	Accelerator pedal pressed (half-way)		0.5 - 4V

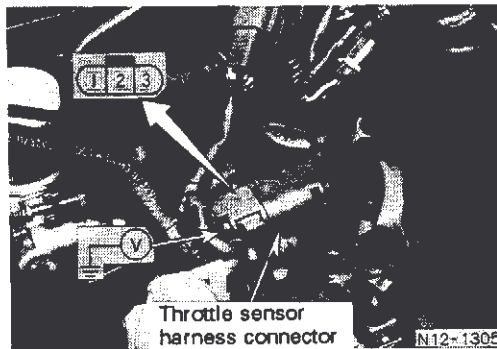

(3) Throttle sensor power inspection

- Measure the voltage between the following terminals and ground with throttle sensor harness connected.

		Engine	RB26DETT
Condition	Measurement location		Between throttle sensor terminal (1) and ground
	Ignition switch ON and engine running		Approx. 5V

B3 ECCS (Electronically Concentrated Engine Control System)

6. Sensor System Inspection (Cont'd)

(4) Throttle sensor inspection

- Remove the throttle sensor connector and measure the resistance between the following terminals when the accelerator pedal is pressed and not pressed.

Engine	RB26DETT
Measurement location	Between throttle sensor terminals (2) and (3)
Condition	
Accelerator pedal not pressed.	Approx. 2 k Ω
Accelerator pedal partially pressed.	Approx. 2 - 10 k Ω (Resistance increases as pedal is pressed.)
Accelerator pedal fully pressed.	Approx. 10 k Ω

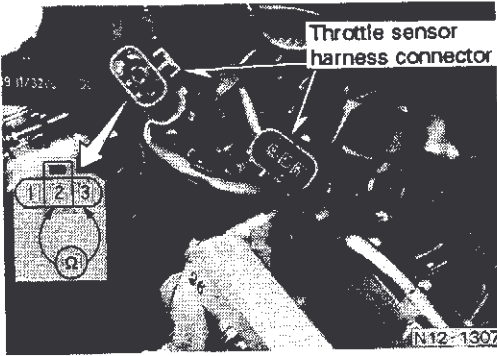

(5) Harness continuity inspection

- Remove the ECCS control unit and throttle sensor connectors and measure the resistance between the following terminals.

Engine	RB26DETT			0 Ω
	ECCS C/U harness	Throttle sensor harness		
Measurement location	Terminals (48)	to (1)		
	(38)	to (2)		
	(30)	to (3)		

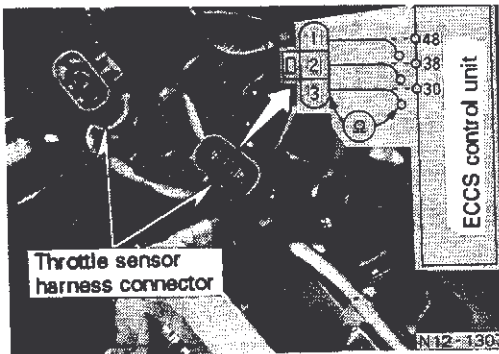

(6) Throttle sensor inspection



- Warm engine adequately and check operation using "THROTTLE SENSOR ADJUSTMENT" in "WORK SUPPORT" mode. (The throttle sensor does not need to be adjusted.)

```

■ THROTTLE SEN ADJ ■
CHECK THE THROTTLE
SENSOR SIGNAL.
ADJUST IT TO THE SPEC-
IFIED VALUE BY ROTATING
THE SENSOR BODY UNDER
THE FOLLOWING CONDITION
• IGN SW "ON"
• ENG NOT RUNNING
• ACC PEDAL KEPT OFF

START
    
```

```

■ THROTTLE SEN ADJ ■ □
**** ADJ MONITOR ****
THROTTLE SEN    0.50V

=== MONITOR ===
CAS-RPM (POS)   950rpm
IDLE POSITION     ON
    
```

B3 ECCS (Electronically Concentrated Engine Control System)

6. Sensor System Inspection (Cont'd)

6-5 INTAKE AIR TEMPERATURE SENSOR SYSTEM INSPECTION

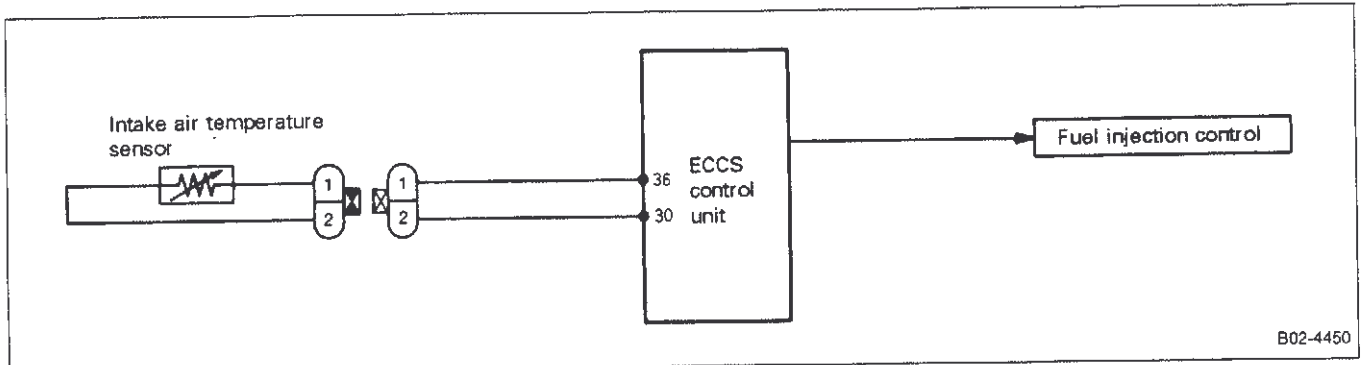

Intake air temperature sensor system trouble diagnosis flowchart

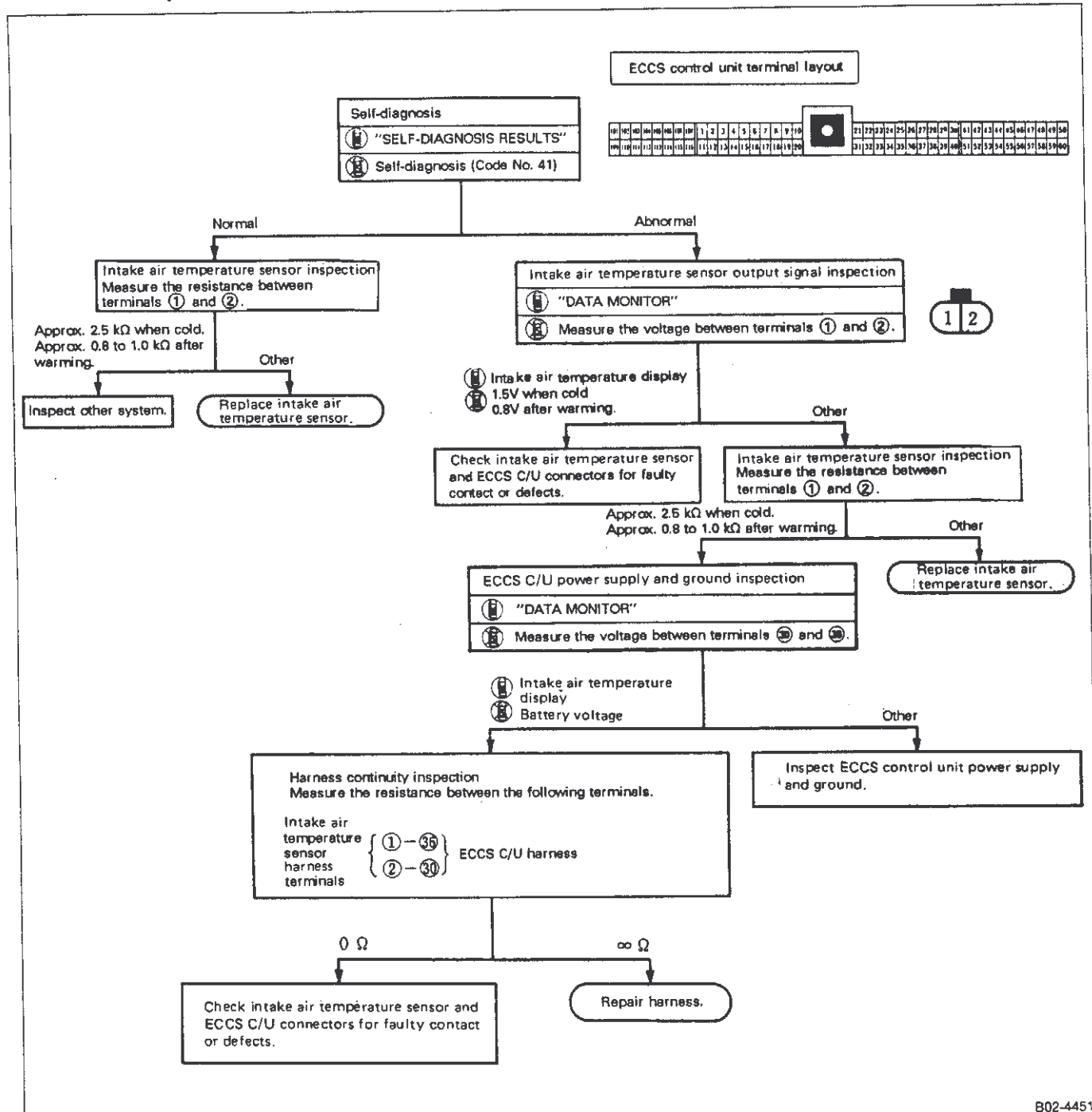

B3 ECCS (Electronically Concentrated Engine Control System)

6. Sensor System Inspection (Cont'd)

(1) Self-diagnosis

- There is a disconnection or short-circuit in the signal system when "CODE No. 41" in regular self-diagnosis or "FAILURE DETECTED IN T/A TEMP SEN" (when CONSULT is used) is displayed.
- If the problem reoccurs, use real-time diagnosis mode (CONSULT data monitor) or an oscilloscope to check for instantaneous break in the signal.

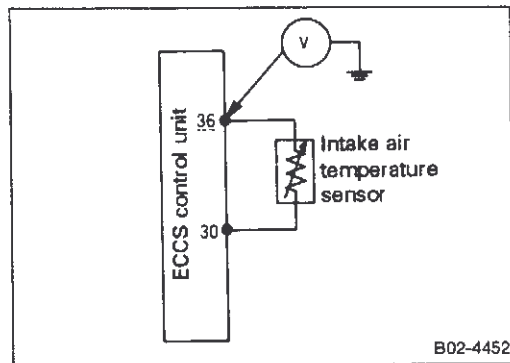
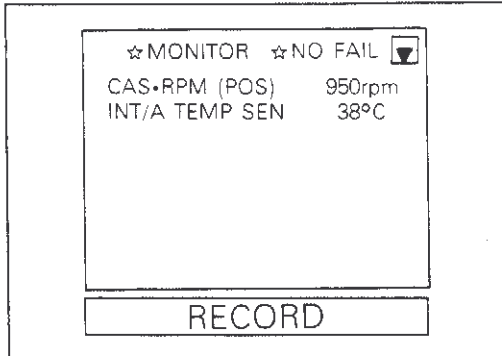

(2) Input signal inspection

- Use the "INT/A TEMP SEN" setting of "DATA MONITOR" mode to check the following items.

Condition	Measurement location
Ignition switch ON	Intake air temperature sensor
Idling	Temperature display corresponds to intake air temperature.

- Measure the voltage between the following terminals and ground with ECCS control unit harness connected.

Condition	Measurement location	Between ECCS C/U terminal (36) and ground
Ignition switch OFF		0V
Ignition switch ON	Approx. 20°C (68°F)	1.5V
	Approx. 45°C (113°F)	0.8V
Idling	Approx. 20°C (68°F)	1.5V
	Approx. 45°C (113°F)	0.8V

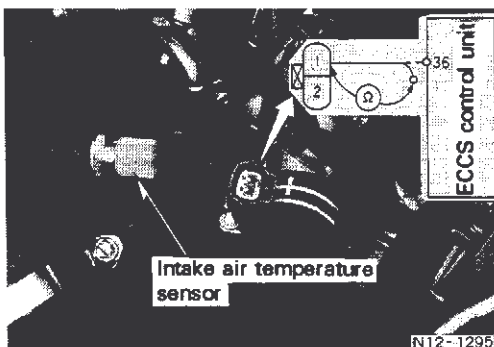

(3) Harness continuity inspection

- Remove the ECCS control unit and intake air temperature sensor connectors and measure the resistance between the following terminals.

Measurement location	Between ECCS control unit harness terminal (36) and intake air temperature sensor harness terminal (1)
	0Ω

B3 ECCS (Electronically Concentrated Engine Control System)

6. Sensor System Inspection (Cont'd)

(4) Intake air temperature sensor inspection

- Remove the intake air temperature sensor connector, heat or cool it with a hair dryer or industrial dryer and measure the resistance between the following terminals.

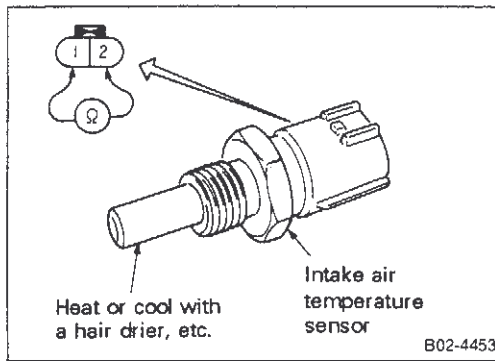

Measurement location	Between intake air temperature sensor terminals (1) and (2)
Condition	
Approx. 20°C (68°F)	Approx. 2.5 kΩ
Approx. 50°C (122°F)	Approx. 0.8 - 1.0 kΩ

B3 ECCS (Electronically Concentrated Engine Control System)

6. Sensor System Inspection (Cont'd)

6-6 ENGINE TEMPERATURE SENSOR SYSTEM INSPECTION

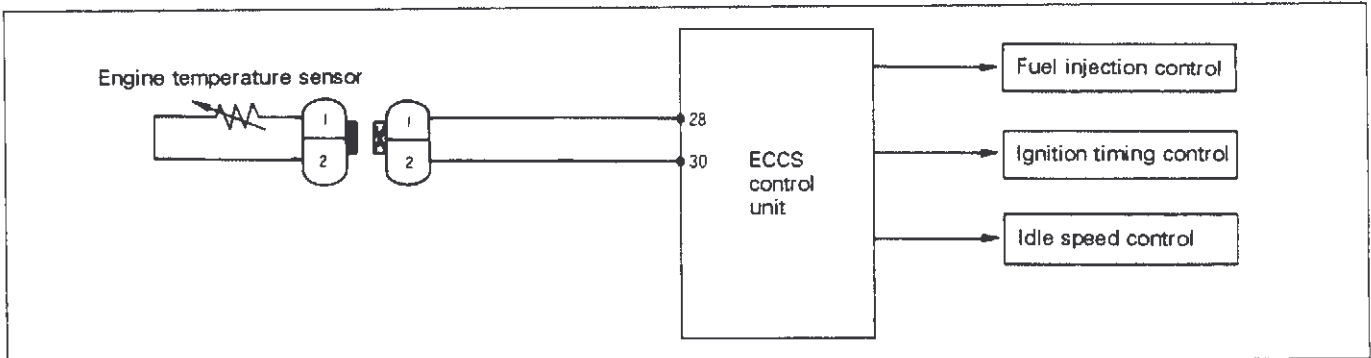

Engine temperature sensor system trouble diagnosis flowchart

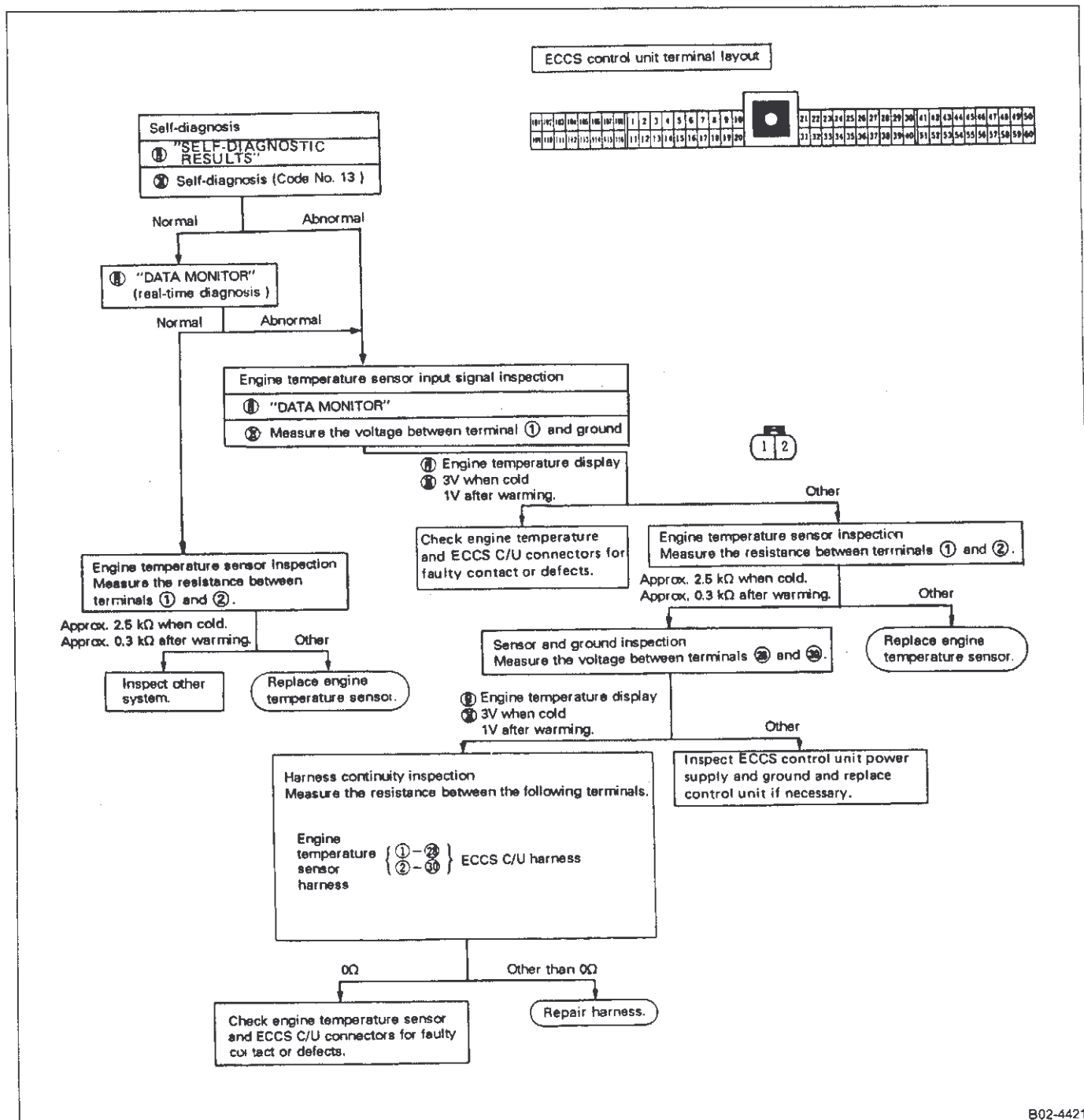

B3 ECCS (Electronically Concentrated Engine Control System)

6. Sensor System Inspection (Cont'd)

(1) Self-diagnosis

- There is a disconnection or short-circuit in the signal system when "CODE No. 13" in regular self-diagnosis or "FAILURE DETECTED ENG TEMP SEN" (when CONSULT is used) is displayed.
-  If the problem reoccurs, use real-time diagnosis mode (CONSULT DATA MONITOR mode) or an oscilloscope to check for instantaneous break in the signal.

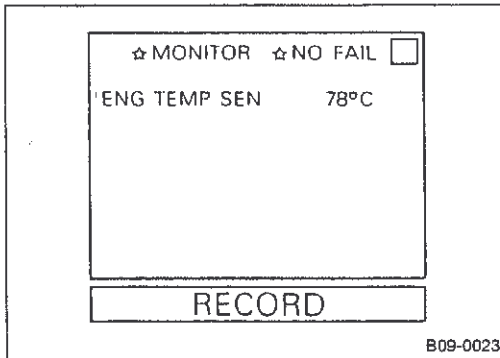

(2) Input signal inspection

-  Use the "WATER TEMP. SENSOR" setting of "DATA MONITOR" to check the following items.

Condition	Item	Engine temperature sensor
Ignition switch ON		Engine temperature is displayed.

CAUTION:

When engine temperature sensor malfunctions, it is set to a fixed value by the fail-safe function.

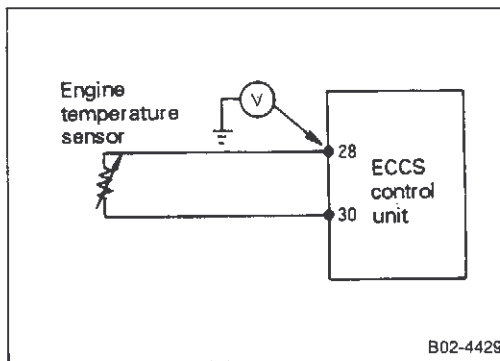

-  Measure the voltage between the following terminals and ground with ECCS control unit harness connected.

Condition	Measurement location	Engine	RB26DETT
		Between ECCS C/U terminal (28) and ground	
Ignition switch ON	Engine temperature	Approx. 20°C (68°F)	Approx. 3V
		Approx. 80°C (176°F)	Approx. 1V

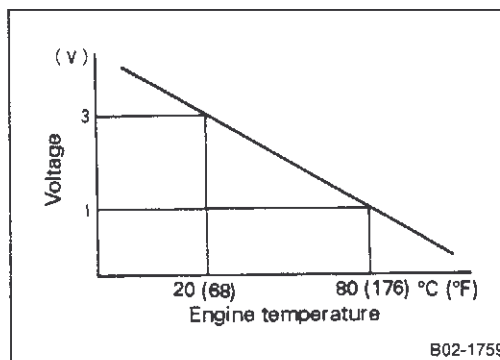

B3 ECCS (Electronically Concentrated Engine Control System)

6. Sensor System Inspection (Cont'd)

(3) Engine temperature sensor resistance value inspection

- Remove the engine temperature sensor connector and measure the resistance between the following terminals.

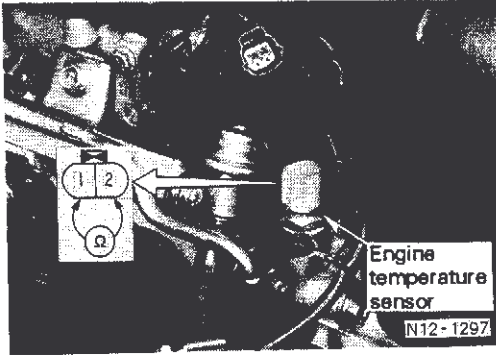

Condition		Engine	RB26DETT
		Measurement location	
		Between engine temperature sensor connector terminals (1) and (2)	
Engine temperature	Approx. 20°C (68°F)	Approx. 2.5 kΩ	
	Approx. 80°C (176°F)	Approx. 0.3 kΩ	

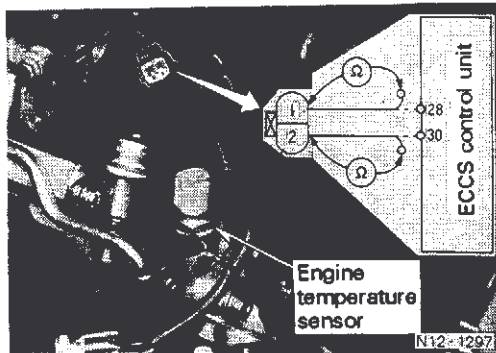

(4) Harness continuity inspection

- Remove the ECCS control unit and engine temperature sensor harness connectors and measure the resistance between the following terminals.

Engine	RB26DETT		
	ECCS C/U harness	Engine temperature sensor harness	
Measurement location	Terminal (28)	to terminal (1)	0Ω
	Terminal (30)	to terminal (2)	

B3 ECCS (Electronically Concentrated Engine Control System)

6. Sensor System Inspection (Cont'd)

6-7 EXHAUST GAS SENSOR SYSTEM INSPECTION

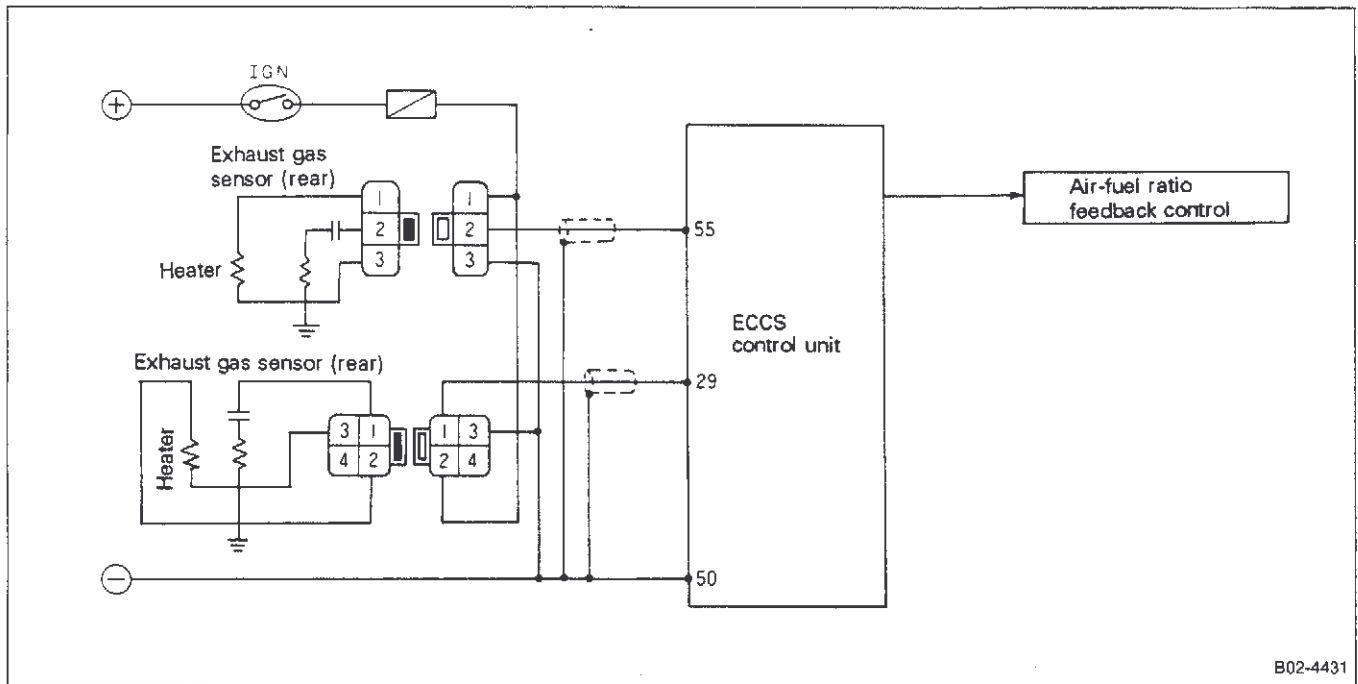

B02-4431

Cylinder, exhaust gas sensor, CONSULT (DATA MONITOR) display

Cylinder No.	Exhaust gas sensor	ECCS C/U terminal number	CONSULT (DATA MONITOR) display
No. 1, 2, 3, cylinders	Exhaust gas sensor (Front)	ECCS C/U terminal (29)	EXH GAS SEN-R
No. 4, 5, 6 cylinders	Exhaust gas sensor (Rear)	ECCS C/U terminal (55)	EXH GAS SEN

B3 ECCS (Electronically Concentrated Engine Control System)

6. Sensor System Inspection (Cont'd)

Exhaust gas sensor system trouble diagnosis flowchart

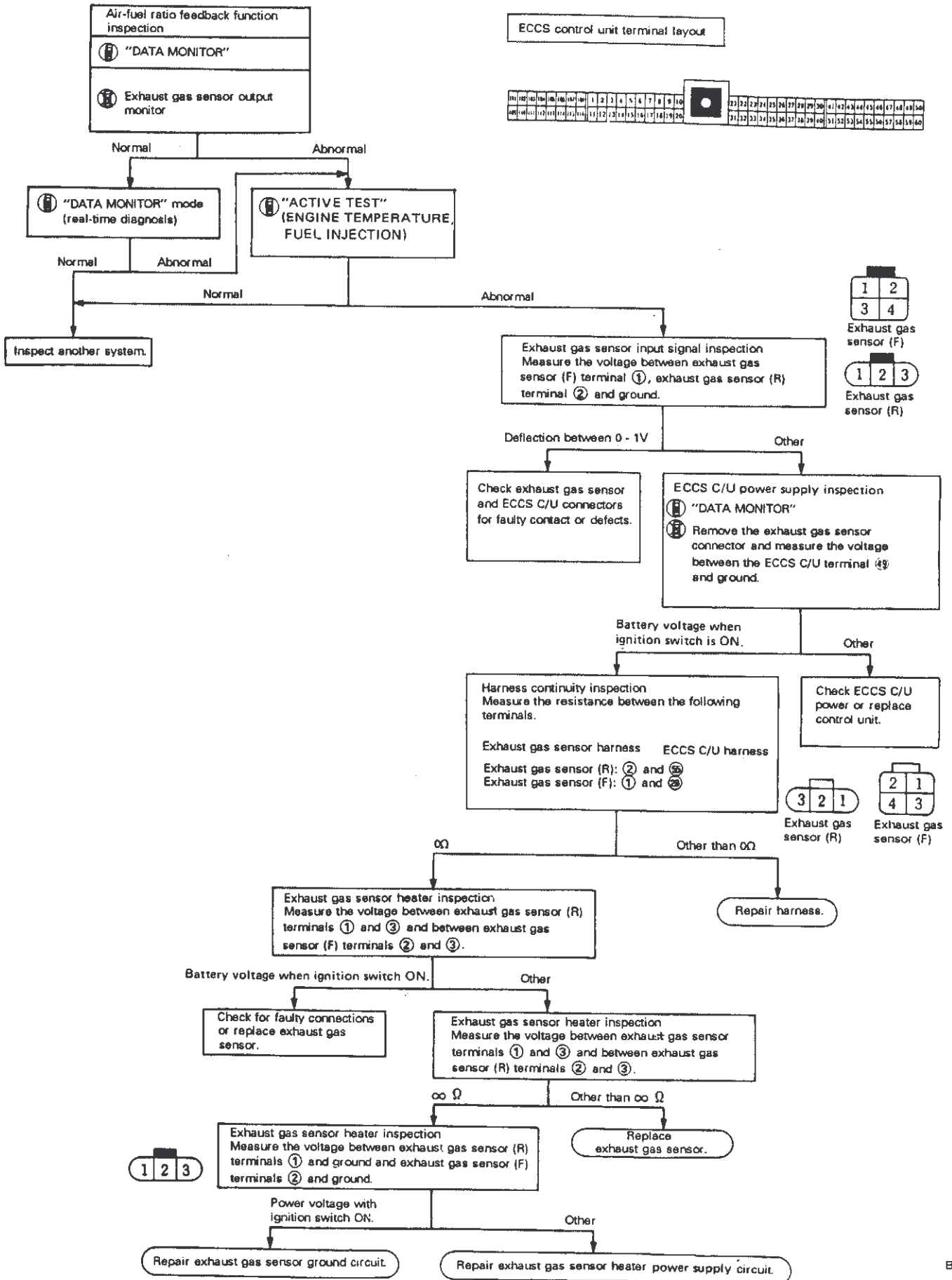

B3 ECCS (Electronically Concentrated Engine Control System)

6. Sensor System Inspection (Cont'd)

(1) Fuel-air ratio feedback function inspection



- Warm the engine and check the following items with "EXH GAS SEN", "EXH GAS SEN-R" (output voltage) and "M/R F/C MNT", "M/R F/C MNT-R" (lean/rich) displayed in "DATA MONITOR" mode.

☆ MONITOR	☆ NO FAIL	<input type="checkbox"/>
CAS•RPM (POS)	1.975rpm	
EXH GAS SEN	1.14V	
EXH GAS SEN-R	1.03V	
M/R F/C MNT	RICH	
M/R F/C MNT-R	RICH	
RECORD		

Condition	Item	Exhaust gas sensor, exhaust gas sensor (R)	Exhaust gas sensor monitor, exhaust gas sensor monitor (R)
		(Output voltage display)	
Engine speed, at approx. 2,000 rpm		Approx. 0 - 1V is displayed. The display cycle is 5 times or more in 10 sec interval.	RICH, LEAN display must be synchronized with output voltage display.

■ ACTIVE TEST	<input type="checkbox"/>		
FUEL INJECTION	0%		
== == MONITOR == ==			
CAS•RPM (REF)	937rpm		
ENG TEMP SEN	59°C		
EXH GAS SEN	1.33V		
EXH GAS SEN-R	1.35V		
INJ PULSE	1.8msec		
AAC VALVE	17%		
Qu	UP	DWN	Qd

- Provide setting value in "ACTIVE TEST" (fuel injection quantity correction) and check exhaust gas sensor function



- Using diagnosis connector on the vehicle side (at fuse block), set CONSULT to "EXHAUST GAS SENSOR MONITOR" and check fuel injection condition by flashing of exhaust gas temperature warning lamp on instrument panel.

Exhaust gas sensor function

Exhaust gas temperature warning lamp must flash 5 times or more in 10-sec interval when engine is running at approx. 2,000 rpm.

Feedback function

Exhaust gas temperature warning lamp must flash periodically when engine speed is running at approx. 2,000 rpm.

B3 ECCS (Electronically Concentrated Engine Control System)

6. Sensor System Inspection (Cont'd)

(1) Fuel-air ratio feedback function inspection



- Warm the engine and check the following items with "EXH GAS SEN", "EXH GAS SEN-R" (output voltage) and "M/R F/C MNT", "M/R F/C MNT-R" (lean/rich) displayed in "DATA MONITOR" mode.

☆MONITOR	☆NO FAIL	<input type="checkbox"/>
CAS-RPM (POS)	1,975rpm	
EXH GAS SEN	1.14V	
EXH GAS SEN-R	1.03V	
M/R F/C MNT	RICH	
M/R F/C MNT-R	RICH	
RECORD		

Condition	Item	Exhaust gas sensor, exhaust gas sensor (R)	Exhaust gas sensor monitor, exhaust gas sensor monitor (R)
			(Output voltage display)
Engine speed, at approx. 2,000 rpm		Approx. 0 - 1V is displayed. The display cycle is 5 times or more in 10 sec interval.	RICH, LEAN display must be synchronized with output voltage display.

■ ACTIVE TEST	■	<input type="checkbox"/>	
FUEL INJECTION	0%		
= = = MONITOR = = =			
CAS-RPM (REF)	937rpm		
ENG TEMP SEN	59°C		
EXH GAS SEN	1.33V		
EXH GAS SEN-R	1.35V		
INJ PULSE	1.8msec		
AAC VALVE	17%		
Qu	UP	DWN	Qd

- Provide setting value in "ACTIVE TEST" (fuel injection quantity correction) and check exhaust gas sensor function



- Using diagnosis connector on the vehicle side (at fuse block), set CONSULT to "EXHAUST GAS SENSOR MONITOR" and check fuel injection condition by flashing of exhaust gas temperature warning lamp on instrument panel.

Exhaust gas sensor function

Exhaust gas temperature warning lamp must flash 5 times or more in 10-sec interval when engine is running at approx. 2,000 rpm.

Feedback function

Exhaust gas temperature warning lamp must flash periodically when engine speed is running at approx. 2,000 rpm.

B3 ECCS (Electronically Concentrated Engine Control System)

6. Sensor System Inspection (Cont'd)

(2) Input signal inspection

- Measure the voltage between the following terminals and ground with ECCS control unit harness connected.

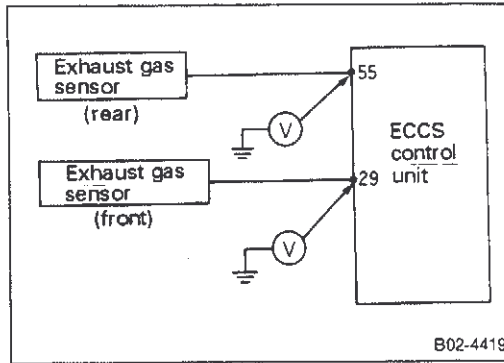

Measurement location	Exhaust gas sensor (Front)	Exhaust gas sensor (Rear)
	Condition	Between ECCS control unit terminal (29) and ground
Racing at approx. 2,000 rpm	Deflection between approx. 0 and 1V	←

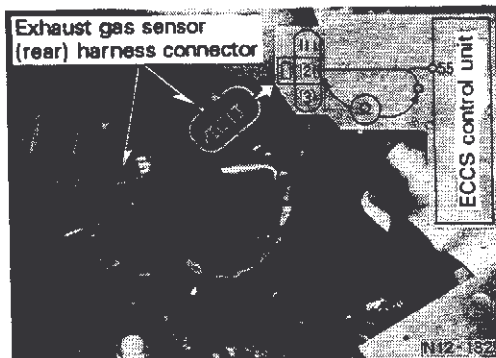

(3) Harness continuity inspection

- Remove the ECCS control unit and exhaust gas sensor connectors and measure the resistance between the following terminals.

Measurement location	Exhaust gas sensor (front)	Exhaust gas sensor (rear)
	Between ECCS control unit harness terminal (29) and exhaust gas sensor harness terminal (1)	0Ω
		0Ω



B3 ECCS (Electronically Concentrated Engine Control System)

6. Sensor System Inspection (Cont'd)

6-8 DETONATION SENSOR SYSTEM INSPECTION

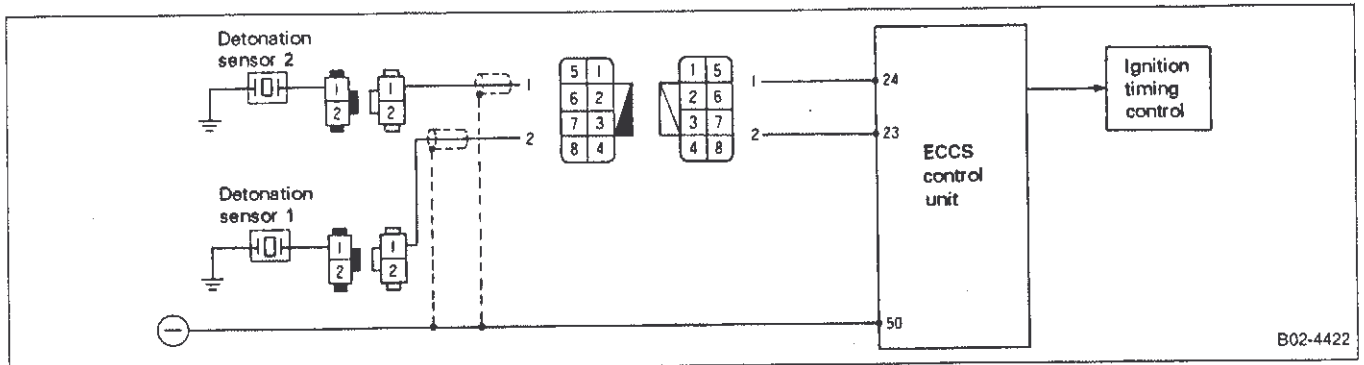

(1) Self-diagnosis

- There is a disconnection or short-circuit in the signal system when "CODE No. 34" in regular self-diagnosis or "FAILURE DETECTED DETONATION SENSOR (when CONSULT is used)" is displayed.
- If the problem reoccurs, use real-time diagnosis mode (CONSULT DATA MONITOR mode) or an oscilloscope to check for instantaneous break in the signal.

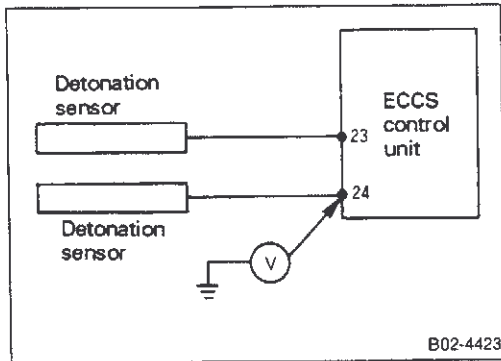

(2) Input signal inspection

- Measure the voltage between the following terminals and ground with ECCS control unit harness connected.

Measurement location	Engine	
	RB26DETT	
Condition	Between ECCS control unit terminal (23) and ground	Between ECCS control unit terminal (24) and ground
Ignition switch ON	Approx. 0.3V	←
Cranking engine	Approx. 0.3V	←
Idling	Approx. 0.3V	←

CAUTION:

The detonation sensor input signal must be measured by an oscilloscope because its resistance is larger than the circuit tester resistance. The signal should also be checked with self-diagnosis and harness continuity inspection.

B3 ECCS (Electronically Concentrated Engine Control System)

6. Sensor System Inspection (Cont'd)

(3) Harness continuity inspection

- Remove the ECCS control unit and detonation sensor middle connector and measure the resistance between the following terminals.

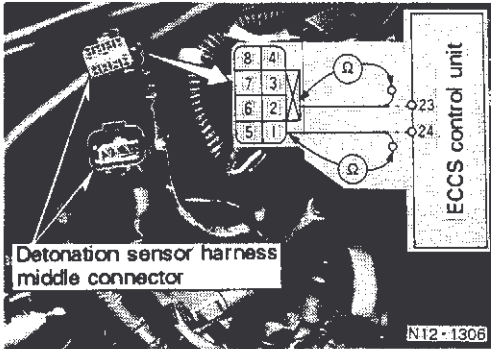

Engine	RB26DETT			
Measurement location	ECCS control unit harness terminal	Detonation sensor middle harness connector terminal		0Ω
	(23) (24)	and	(2) (1)	

6-9 VEHICLE SPEED SENSOR SYSTEM INSPECTION

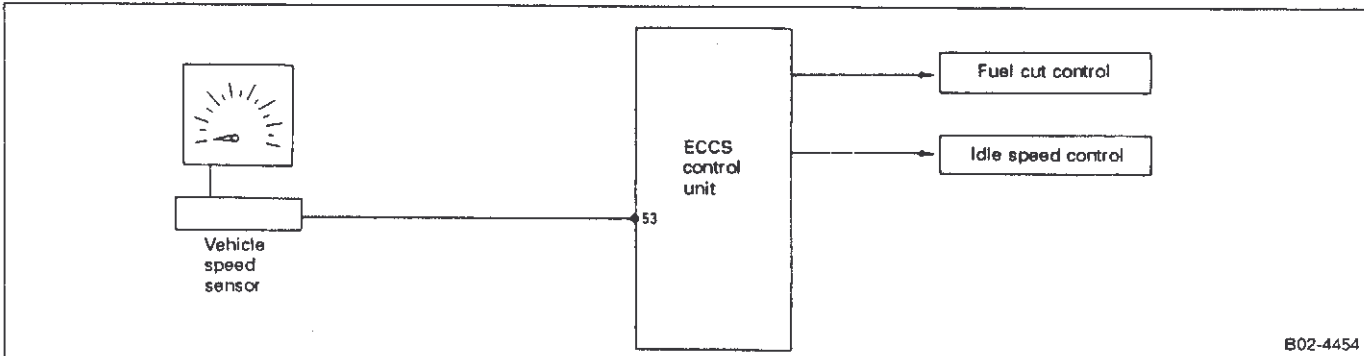

B02-4454

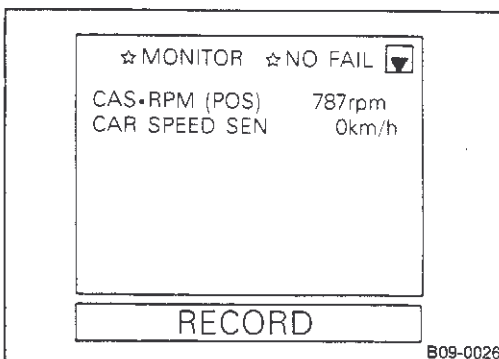

(1) Input signal inspection



- Select "VEHICLE SPEED SENSOR" in "DATA MONITOR" mode and check following items.

Condition	Item	Vehicle speed sensor
When drive wheels are rotating.		Vehicle speed is displayed.

B3 ECCS (Electronically Concentrated Engine Control System)

6. Sensor System Inspection (Cont'd)

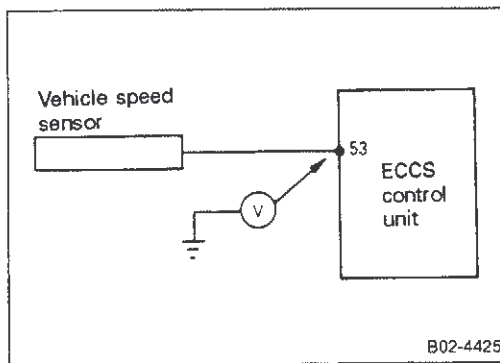

- Measure the voltage between the following terminals and ground with ECCS control unit harness connected.

Engine	RB26DETT
Measurement location	Between ECCS control unit terminal (53) and ground
Condition	When drive wheels are rotating slowly
	Deflection between 0V and 5V (also appears as deflection around 1V).

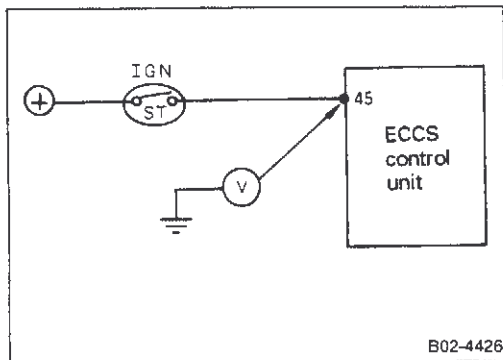

6-10 IGNITION SWITCH (START switch) SIGNAL INSPECTION

(1) Input signal inspection



- In "DATA MONITOR" mode, perform key operation to check if ignition switch "START" signal is input correctly.



- Measure the voltage between the following terminals and ground with ECCS control unit harness connected.

Engine	RB26DETT
Measurement location	Between ECCS control unit terminal (45) and ground
Condition	Other than ignition switch at "START"
	0V
	Ignition switch at "START"
	Battery voltage

6-11 AIR CONDITIONER SIGNAL INSPECTION

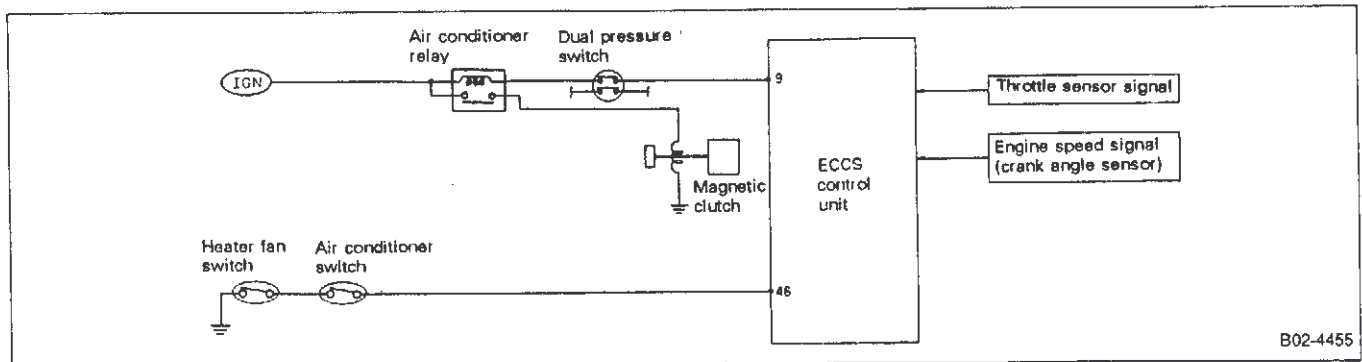

B3 ECCS (Electronically Concentrated Engine Control System)

6. Sensor System Inspection (Cont'd)

(1) Input signal inspection



- In "DATA MONITOR" mode, perform air conditioner switch operation to check if air conditioner switch signal is input correctly.



- Measure the voltage between the following terminals and ground with ECCS control unit harness connected.

Engine	RB26DETT	
Measurement location	Between ECCS control unit terminal (9) and ground	Between ECCS control unit terminal (46) and ground
Condition		
Air conditioner OFF	Battery voltage	8 - 9V
Air conditioner ON	0 - 1V	←

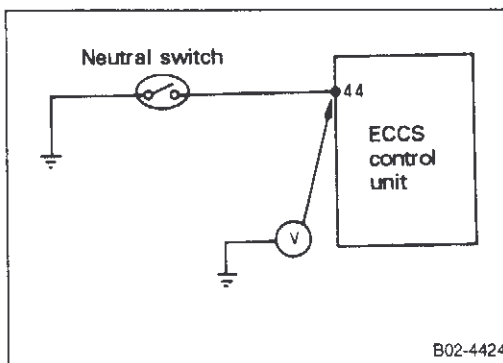

6-12 NEUTRAL SWITCH SIGNAL INSPECTION

(1) Input signal inspection



- In "DATA MONITOR" mode, perform shift lever operation to check if neutral switch signal is input correctly.



- Measure the voltage between the following terminals and ground with ECCS control unit harness connected.

Engine	RB26DETT	
Measurement location	Between ECCS control unit terminal (44) and ground	
Condition		
Ignition switch ON	Not "N" position	4 - 5V
	At "N" position	Approx. 0V

B3 ECCS (Electronically Concentrated Engine Control System)

6. Sensor System Inspection (Cont'd)

6-13 POWER STEERING OIL PRESSURE SWITCH SIGNAL INSPECTION

(1) Input signal inspection



- In "DATA MONITOR" mode, perform power steering operation to check if power steering oil pressure switch signal is input correctly.



- Measure the voltage between the following terminals and ground with ECCS control unit harness connected.

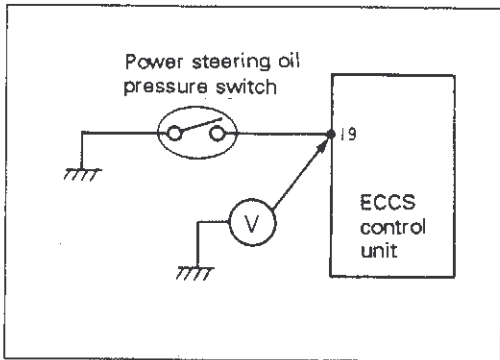

Condition	Measurement location	Between ECCS control unit terminal (19) and ground
Idling	Power steering OFF	Approx. 5V
	Power steering ON	Approx. 0V

B3 ECCS (Electronically Concentrated Engine Control System)

7. ECCS Control Unit Input/Output Signals (RB26DETT)

7-1 CONSULT INSPECTION VALUES

(1) Data monitor

Note: The output signal is displayed as the calculation data on console unit so the correct value will be displayed even if the output circuit (harness) is inadvertently disconnected.

Monitor Item	Data Monitor				Problem Inspection Item	
	Condition		Normal reference value			
CAS-RPM (POS) (detected engine speed according to 1° and 120° signals)	<ul style="list-style-type: none"> ● Tachometer set ● Engine running 		There must be no abnormal change in speed.		Crank angle sensor system	
AIR FLOW MTR (output voltage)	<ul style="list-style-type: none"> ● After warming up engine ● Idling (N range, air conditioner OFF) 		Approx. 0.7 - 1.2V (1.0 - 1.7V at 2,000 rpm with no load) Note: The two air flow meters may have a difference of 0V to 0.4V in some cases.		Air flow meter system	
AIR FLOW MTR-R (output voltage)						
ENG TEMP SEN (engine temperature)	After warming up engine		Above approx. 70°C (158°F)		Engine temperature sensor system	
EXH GAS SEN (output voltage)	After warming up engine	2,000 rpm with no load	Changes between 0 - 0.3V and 0.6 - 1V.		<ul style="list-style-type: none"> ● Exhaust gas sensor system ● Intake system air leak or air intake ● Injector system 	
EXH GAS SEN-R (output voltage)						
M/R F/C MNT (RICH/LEAN)			RICH, LEAN repeats 5 times or more in 10 sec.			
M/R F/C MNT-R (RICH/LEAN)						
CAR SPEED SEN (vehicle speed signal)	While driving or with drive wheels turning.		Should generally conform to speedometer display.		Vehicle speed sensor system	
BATTERY VOLT	<ul style="list-style-type: none"> ● Ignition switch ON ● Engine stopped 		11 - 14V		<ul style="list-style-type: none"> ● Battery ● ECCS control unit power system 	
THROTTLE SEN (output voltage)	<ul style="list-style-type: none"> ● Ignition switch ON ● Engine stopped 	Throttle fully closed.	RB20DET	0.5	● Throttle sensor system	
			RB26DETT	0.5		
		Throttle fully open.	RB20DET	4.0		
			RB26DETT	4.0		
INT/A TEMP SE (intake temperature sensor output)	After warming up engine.		Intake air temperature is displayed.		Intake temperature sensor system	
INJ PULSE (injection pulse width)	After warming up engine.	Idling (N range, air conditioner OFF)	Reference	RB20DET	1.4 - 2.2 msec	<ul style="list-style-type: none"> ● Air flow meter system ● Intake system air leaks or air suction (entire input) ● Input signal system (entire)
INJ PULSE-R (injection pulse width)				RB26DETT		
		2,000 rpm with no load.		RB20DET	1.4 - 2.2 msec	
RB26DETT						

B3 ECCS (Electronically Concentrated Engine Control System)

7. ECCS Control Unit Input/Output Signals (RB26DETT) (Cont'd)

Monitor Item	Data Monitor			Problem Inspection Item	
	Condition	Normal reference value			
IGN TIMING	After warming up engine.	Idling (N range, air conditioner OFF)	RB20DET	15°	● Air flow meter system
			RB26DETT	20°	
		2,000 rpm with no load.	Advance greater than 10° angle compared to idle position.		
AAC VALVE	After warming up engine.	Idling (N range, air conditioner OFF)	Approx. 15 - 35%		● IAS adjustment ● AAC valve system
		2,000 rpm with no load.	(Approx. 30 - 50%)		
A/F ALPHA (air-fuel ratio feedback correction coefficient)	● After warming up engine. ● 2,000 rpm with no load.	75 - 125%		● Air flow meter system ● Injector system ● Canister (purge) inspection ● Intake system air leak or air suction	
A/F ALPHA-R (air-fuel ratio feedback correction coefficient)					
START SIGNAL	● Ignition switch ON ● Engine stopped	"START"	ON		Starter SW system
		"OFF"	OFF		
AIR COND SIG	Idle	Air conditioner SW ON	ON		Air conditioner SW system
		Air conditioner SW OFF	OFF		
NEUTRAL SW		N or P range	ON		Neutral switch system
		Other than N or P range	OFF		
PW/ST SIGNAL		Steering turning	ON		Power steering SW system
		Steering neutral position	OFF		
IDLE POSITION	Idling	ON		Throttle sensor system	
	Other than idling	OFF			
FUEL PUMP RLY	● Ignition switch ON	Stop	OFF		Fuel pump system
		Running	ON		
AIR COND RLY	● Idle	Air conditioner ON	ON		Air conditioner relay system
		Air conditioner OFF	OFF		
	● Within 10 seconds during acceleration	Air conditioner ON	OFF		
W/G CONT S/V		ON			
		OFF			
■ POWER VOLTAGE	Voltage probe measurement value is displayed.				
■ PULSE	Pulse probe measurement value is displayed.				

B3 ECCS (Electronically Concentrated Engine Control System)

7. ECCS Control Unit Input/Output Signals (RB26DETT) (Cont'd)

(2) Active test

Set item	Active Test		Judgment and Inspection Item
	Condition	Active Test Description	
ENGINE TEMPERATURE	Problem occurrence condition	Set engine temperature high or low. Caution: Do not set extreme values as this can cause spark plug burning.	Perform following inspections to check if problem is solved. Eliminate: Engine temperature sensor system Injector system. Air flow meter, exhaust gas sensor system Not eliminated: Other item inspection
FUEL INJECTION	Problem occurrence condition	Set the air-fuel ratio rich or lean. Caution: Do not set extreme values because this may damage engine or catalytic converter.	Perform following inspections to check if problem is solved. Eliminate: Exhaust gas sensor system Air flow meter, engine temperature sensor system Injector system Not eliminated: Other item inspection
IGNITION TIMING	Problem occurrence condition	Delay ignition timing. Caution: Do not set extreme values because this may damage engine or catalytic converter.	Perform following inspections to check if problem is solved. Eliminate: Ignition timing adjustment Detonation sensor system Not eliminated: Other item inspection
AAC VALVE OPENING	Engine running	<ul style="list-style-type: none"> ● Increase control duty ratio. The engine speed should increase. ● Decrease control duty ratio. The engine speed should decrease. 	If the condition described on left cannot be verified, check AAC valve system.
POWER BALANCE	Engine running	Set the AAC valve open to stop the specified injector operation and the injector speed can be displayed at this time. Caution: Do not perform this operation while driving (to preserve the catalyzer.)	Eliminate: Injector system
FUEL PUMP RELAY	<ul style="list-style-type: none"> ● Ignition switch ON. ● Engine stop. 	Turn ignition switch ON, OFF and ON so pump operation makes a sound. The fuel pressure will rise. Caution: Do not perform this operation except under conditions described on left.	If the condition described on left cannot be verified, check relay system of fuel pump and fuel pump system.
SELF-LEARNING CONT	<ul style="list-style-type: none"> ● The air-fuel ratio feedback correction coefficient learning factor is cleared. 		

B3 ECCS (Electronically Concentrated Engine Control System)

7. ECCS Control Unit Input/Output Signals (RB26DETT) (Cont'd)

RB26DETT

RB26DETT



B02-3431

Terminal Number	Signal Name	Circuit	At idle		At approx. 2,500 rpm	
			Standard	Memo	Standard	Memo
1 2 3 11 12 13	Power transistor control signal	<p>B02-1651</p>	<p>0.2 - 0.3V</p> <p>B02-1670</p>		<p>Approx. 0.4V</p> <p>B02-1636</p>	
4	AAC valve control signal	<p>B02-1619</p>	<p>Cold: 6 - 7V Warm: 8 - 10V</p> <p>B02-1668</p>		<p>Approx. 5V</p> <p>B02-1669</p>	
7	Engine speed signal for tachometer	<p>B02-1641</p>	<p>Approx. 1V</p> <p>B02-1658</p>		<p>Approx. 2.4V</p> <p>B02-1659</p>	
9	Air conditioner relay	<p>B02-1623</p>	<p>Air conditioner OFF: Battery voltage Air conditioner ON: Approx. 1V</p>			

B3 ECCS (Electronically Concentrated Engine Control System)

7. ECCS Control Unit Input/Output Signals (RB26DETT) (Cont'd)

RB26DETT

101	102	103	104	105	106	107	108	1	2	3	4	5	6	7	8	9	10		21	22	23	24	25	26	27	28	29	30	41	42	43	44	45	46	47	48	49	50
109	110	111	112	113	114	115	116	11	12	13	14	15	16	17	18	19	20		31	32	33	34	35	36	37	38	39	40	51	52	53	54	55	56	57	58	59	60

RX	TX				CHK	IGN
⊖	CLK					

802-3431

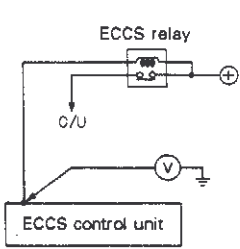
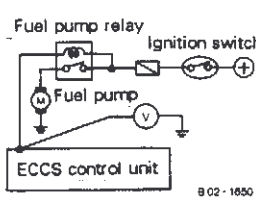
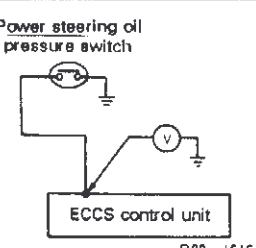
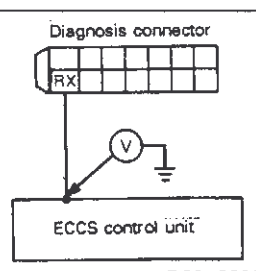
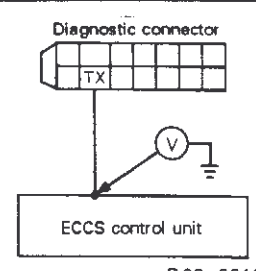
Terminal Number	Signal Name	Circuit	At idle		At approx. 2,500 rpm	
			Standard	Memo	Standard	Memo
16	ECCS relay	 <p>B02-1639</p>	Approx. 1V (Ignition switch OFF: Battery voltage)		Approx. 0V	
18	Fuel pump relay	 <p>802-1650</p>	0V		0V	
19	Power steering oil pressure switch signal	 <p>B02-1616</p>	Power steering ON: 0V Power steering OFF: 5V		←	
21 (RX)	Receive (control unit data reception)	 <p>B02-3609</p>	10V		←	
22 (TX)	Transmit (data transmission from control unit)	 <p>B02-3610</p>	0V		←	

B3 ECCS (Electronically Concentrated Engine Control System)

7. ECCS Control Unit Input/Output Signals (RB26DETT) (Cont'd)

RB26DETT

101	102	103	104	105	106	107	108	1	2	3	4	5	6	7	8	9	10		21	22	23	24	25	26	27	28	29	30	41	42	43	44	45	46	47	48	49	50
109	110	111	112	113	114	115	116	11	12	13	14	15	16	17	18	19	20		31	32	33	34	35	36	37	38	39	40	51	52	53	54	55	56	57	58	59	60

RX	TX			CHK	IGN
	CLK				

B02-3431

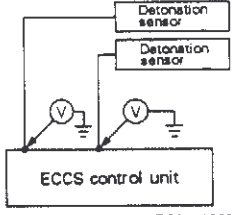
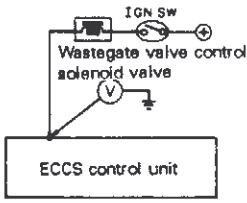
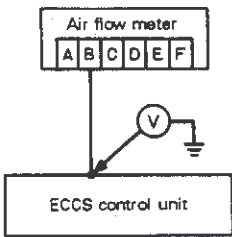
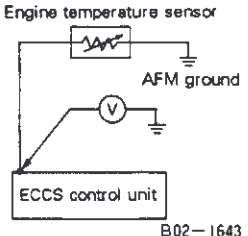
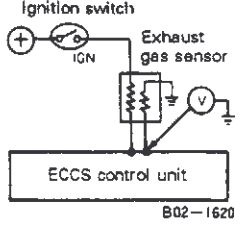
Terminal Number	Signal Name	Circuit	At idle		At approx. 2,500 rpm	
			Standard	Memo	Standard	Memo
23 24	Detonation sensor signal	 <p>B02-1629</p>	Approx. 0.3V		←	
25	Wastegate valve control solenoid valve	 <p>B02-3616</p>	Power voltage		Approx. 0V	
27	Air flow meter (rear) (Intake air quantity signal)	 <p>B02-3611</p>	Approx. 1V		Approx. 1.5V	
28	Engine temperature sensor signal	 <p>B02-1643</p>	Engine temperature 80°C (176°F): Approx. 1V Engine temperature 20°C (68°F): Approx. 3V		←	
29	Exhaust gas sensor signal (front)	 <p>B02-1620</p>	Approx. 0 - 1V		Deflects between approx. 0 - 1V	

B3 ECCS (Electronically Concentrated Engine Control System)

7. ECCS Control Unit Input/Output Signals (RB26DETT) (Cont'd)

RB26DETT

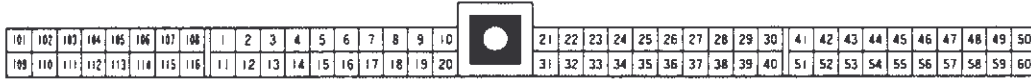

B02-3431

Terminal Number	Signal Name	Circuit	At idle		At approx. 2,500 rpm	
			Standard	Memo	Standard	Memo
31 (CLK)	Clock (synchronization signal)	<p>B02-3612</p>	0V		←	
32	Monitor and check lamp (red lamp)	<p>B02-3476</p>	Lamp not lit: Power voltage Lamp is lit: 0V		←	
35	Air flow meter (front) (Intake air quantity signal)	<p>B02-3611</p>	Approx. 1V		Approx. 1.5V	
36	Intake air temperature sensor signal	<p>B02-2410</p>	Cold: approx. 1.5V Warm: approx. 0.8V		←	
38	Throttle sensor signal	<p>B02-1617</p>	Approx. 0.5V		0.5 - 4V (Voltage increases if accelerator pedal is pressed.)	

B3 ECCS (Electronically Concentrated Engine Control System)

7. ECCS Control Unit Input/Output Signals (RB26DETT) (Cont'd)

RB26DETT



B02-3431

Terminal Number	Signal Name	Circuit	At idle		At approx. 2,500 rpm	
			Standard	Memo	Standard	Memo
41 51	Crank angle sensor 120° signal	<p>B02-1645</p>	<p>0.3 - 0.7V</p> <p>B02-1660</p>		<p>0.3 - 0.7V</p> <p>B02-1661</p>	
42 52	Crank angle sensor 1° signal	<p>B02-1646</p>	<p>2 - 3V</p> <p>B02-1662</p>		<p>2 - 3V</p> <p>B02-1653</p>	
43	Ignition switch (Start signal)	<p>B02-1960</p>	<p>0V (Ignition switch at START: battery voltage)</p>		<p>0V</p>	
44	Neutral switch signal		<p>N. or P. range: 0V Other than N or P range: 4 - 5V</p>		<p>←</p>	
46	Air conditioner switch signal	<p>B02-1627</p>	<p>Air conditioner OFF: Battery voltage Air conditioner ON: 0V</p>		<p>←</p>	

B3 ECCS (Electronically Concentrated Engine Control System)

7. ECCS Control Unit Input/Output Signals (RB26DETT) (Cont'd)

RB26DETT

181	182	183	184	185	186	187	188	1	2	3	4	5	6	7	8	9	10		21	22	23	24	25	26	27	28	29	30	41	42	43	44	45	46	47	48	49	50
189	110	111	112	113	114	115	116	11	12	13	14	15	16	17	18	19	20		31	32	33	34	35	36	37	38	39	40	51	52	53	54	55	56	57	58	59	60

RX	TX			CHK	IGN
⊖	⊖	⊖	⊖		

B02-343

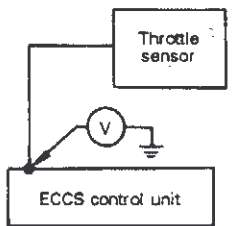
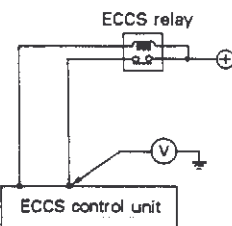
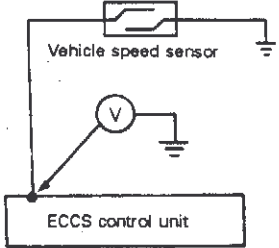
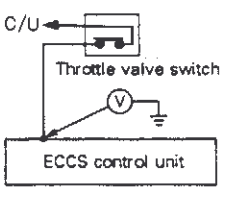
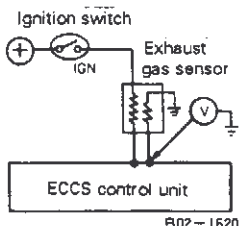
Terminal Number	Signal Name	Circuit	At idle		At approx. 2,500 rpm	
			Standard	Memo	Standard	Memo
48	Throttle sensor (power supply)	 <p>B02-1961</p>	5V		←	
49	Control unit power supply	 <p>B02-3477</p>	Battery voltage		←	
53	Vehicle speed sensor signal	 <p>B02-1618</p>	D range (or 1st) with rear wheels jacked up: 0.5 - 1.5V The value actually deflects between 0V and 5V. However, it appears to deflect around 1V, according to vehicle speed.		←	
54	Throttle valve switch (idle contact point)	 <p>B02-4456</p>	Approx. 10V		Accelerator pressed: 0V	
55	Exhaust gas sensor signal (rear)	 <p>B02-1620</p>	Approx. 1V		Deflects between 0 - 1V	

B3 ECCS (Electronically Concentrated Engine Control System)

7. ECCS Control Unit Input/Output Signals (RB26DETT) (Cont'd)

RB26DETT						
802-3431						
Terminal Number	Signal Name	Circuit	At idle		At approx. 2,500 rpm	
			Standard	Memo	Standard	Memo
56	Throttle sensor output signal	<p style="text-align: center;">B02-4457</p>	Approx. 0.5V		Approx. 0.5 - 4V (Voltage increases as accelerator pedal is pressed.)	
57	Throttle valve switch (power supply)		Battery voltage		←	
101 103 105 110 112 114	Injector control signal	<p style="text-align: center;">B02-1628</p>	Approx. battery voltage.	<p style="text-align: center;">B02-1664</p>	Approx. battery voltage.	<p style="text-align: center;">B02-1665</p>
104	Fuel pump terminal voltage control signal (FPCM1)	<p style="text-align: center;">B02-1630</p>	Idling (after warming engine): 0V		During middle load: 4V	
106	Fuel pump terminal voltage control signal (FPCM2)	<p style="text-align: center;">B02-1630</p>	—		During middle load: 0V	

B3 ECCS (Electronically Concentrated Engine Control System)

7. ECCS Control Unit Input/Output Signals (RB26DETT) (Cont'd)

7-3 ECCS CONTROL UNIT OPERATION CAUTIONS

(1) Control unit equipment

- Never install a control unit that is not specified for the vehicle.
- Do not apply excessive force to the installation bracket.

(2) Connector removal and installation

- When removing and installing connectors, do not bend or apply unnecessary force and observe following points.

① Connector removal

- Turn ignition switch OFF and ECCS relay OFF before removing connectors.
- Hold connector firmly to disconnect without applying force to harness.
- Do not use a screwdriver or similar tool to loosen the connector lock.

② Connector installation

- Turn ignition switch OFF.
- Make sure pins are not bent on control unit connector and then connect securely.
- Tighten bolts securely until injector surface reaches orange color indicator of connector and surface is even.

(3) Control unit power

- Never make a reverse connection to the battery.
- Use battery voltage in 10 - 16V range.

(4) Idle speed adjustment knob

- Do not turn past lock position.
- Do not turn adjustment knob when ambient temperature lower than 0° (32°F).

(5) Water and Oil

- Be careful not to allow rain drops or water to wet the control unit.
- Be careful that condensation does not form due to sudden increase in temperature. If there is any moisture, dry control unit adequately before installing in vehicle.
- Make sure no oil adheres to connectors.
- Do not clean the control unit with volatile solvent cleaners.

(6) Dropping and Impact

- Do not drop the control unit or subject it to strong impact.
- Do not use upper and lower covers for the control unit which are dented.

(7) Control unit screws and cover

- Do not remove the upper and lower covers from the control unit.
- Do not turn the screws in the control unit main body.

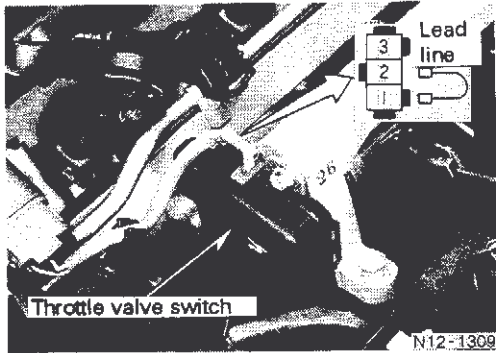

8. Deceleration Exhaust Gas Emission Control Equipment Inspection

8-1

Throttle valve switch short-circuit

- Remove the throttle valve switch harness connector and use a lead line to connect harness connector terminals (2) and (3). (The throttle valve sequence power and idle connection points are set ON.)

Fuel cut inspection

- After warming engine, place the transmission in neutral and run engine at 2,000 rpm. Lower the speed to approx. 1,000 rpm and then raise the speed to 2,000 rpm again and check for fuel cut. (If the accelerator opening angle is fixed, repeat the procedures described above.)

9. Air Conditioner Cut System Inspection

9-1 AIR CONDITIONER CUT SYSTEM FUNCTION INSPECTION

- When the engine is idling, turn air conditioner switch ON and then race the engine. Make sure the air conditioner compressor goes ON and then OFF.

B4 ENGINE ELECTRICAL EQUIPMENT

Preparation tools

	Name	Application
Measurement equipment	Hydrometer	Battery specific gravity inspection
	Circuit tester	Resistance, voltage inspections

Specifications

Item	Engine		RB26DETT
	Standard	(V-Ah)	
Battery type (capacity)	Standard	(V-Ah)	34B19R (12-17)
	Option	(V-Ah)	80D26R (12-55)
Alternator type (output)	Standard	Mitsubishi (V-A)	A3T45594 (12-90A)
Starter motor (output)	Standard	Hitachi (kW)	S114-505 (1.4)
		Mitsubishi (kW)	MIT-70685 (1.4)
Injection coil		Hanshin	MCP302
Distributor		Hitachi	D6Y88-01
		Mitsubishi	T0T49171
Spark plug (arc gap)	Standard	NGK	PFR6A-11 (1.1)
	Option	NGK	PFR5A-11 (1.1) PFR7A-11 (non-adjustable)

Note: The battery capacity value is the 5-hour rate that conforms to the new JIS standard and the value is 80% of the former 20-hour rate.

[New model name] (example)

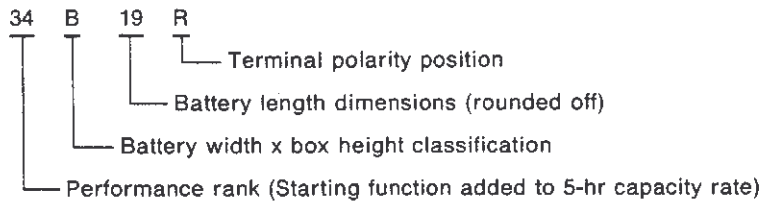

B4 ENGINE ELECTRICAL EQUIPMENT

1. Battery Inspection

Voltage inspection

Normal	(V)	12.4 - 12.8
Limit (charge required)	(V)	12.4V or less
(Start limit)	(V)	12V [20°C (68°F)]

Specific gravity inspection [20°C (68°F)]

Normal		1.29 - 1.22
Limit (charge required)	(V)	1.22 or less
Service life		There is a variation width of more than 0.04 between each cell.

- Additional water does not need to be added to the battery during the service life of normal driving. When driving for extended periods of time in high temperatures, the fluid level may decrease according to vehicle driving conditions. Check the fluid level with the level indicator (upper, lower) and replenish to the upper level as necessary.

Note: Distilled water must be used to refill the battery. If ordinary water is used, fluid loss will increase and may cause discharge.

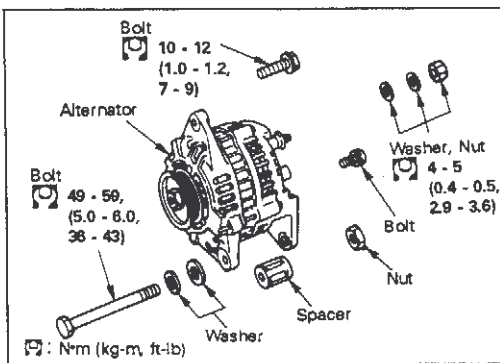

Additional work required:
Belt tension inspection and adjustment

2. Alternator

(1) Alternator removal and installation

(2) Alternator inspection

Output voltage inspection

- Turn ignition switch ON and check that charge warning lamp lights.

Standard	(V/rpm)	13.9 - 14.9/2,000 (accessories OFF)
----------	---------	-------------------------------------

B4 ENGINE ELECTRICAL EQUIPMENT

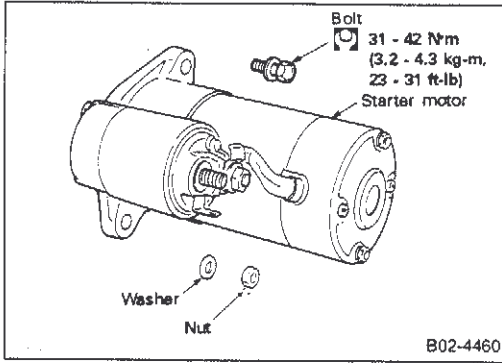

3. Starter Motor Removal and Installation

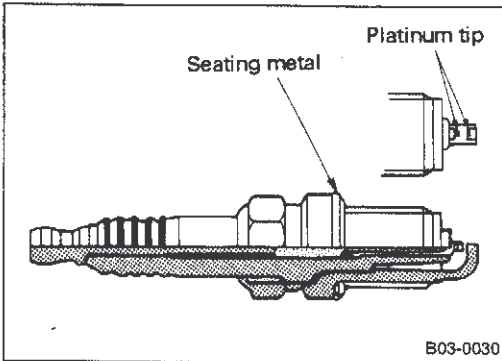

4. Platinum Plug Inspection

Installation Precautions

Periodic replacement interval: 100,000 km (60,000 miles)

- Gap inspection and adjustment and plug cleaning with wire brush should not be performed because this may scrape off the platinum particulate from the platinum tip surface. If plugs are cleaned with an air cleaner, the cleaning should be performed in less than 20 seconds at an air pressure less than 588 kPa (6.0 kg/cm², 85 psi).
- When replacing the spark plugs, always use parts specified by Nissan.

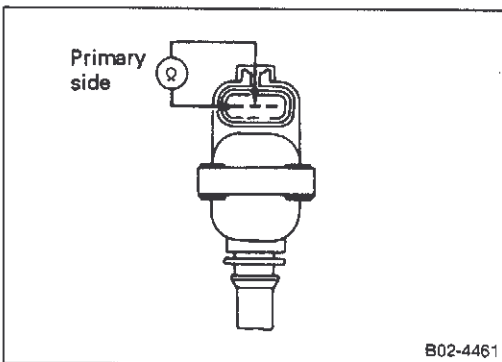

5. Ignition Coil Inspection

- Check the primary and secondary coil resistance value.

Item	Engine	
		RB26DETT
Primary resistance	Ω	0.6 - 0.9
Secondary resistance	k Ω	—

B5 COOLING SYSTEM

Preparation tools

	Name	Application
Special tool	Radiator cap tester EG1765 0000	Radiator and cap pressure test
	Radiator cap hose adapter EG1765 0301	Small cap adapter

Specifications

Item		Engines	RB26DETT
Radiator	Core size (vertical × horizontal × thickness) mm (in)		380 × 646 × 25 (14.96 × 25.43 × 0.98)
	Fin pitch mm		15
	Cap injection-valve opening pressure kPa (kg/cm ² , psi)		88 (0.9, 13)
	Radiation performance (kcal/h°C)		1,080
	A/T oil cooler		—
	Tank material		Plastic
	Core material		Aluminum
Shroud			One-piece unit (lower shroud)
Cooling fan	External diameter mm (in) × number of layers		420 (16.54) × 8
	Coupling		3 levels
Sub electrical cooling fan	External diameter mm (in) × number of layers		320 (12.60) × 4
	Motor output (W)		160
	Engine temperature switch operation °C (°F)		90 (194)
Thermostat injection-valve opening engine temperature [standard] °C (°F)			76.5 (170)
LLC mixture proportion [standard/cold region] (%)			30
Reserve tank capacity ℓ (Imp qt)			Approx. 0.7 (5/8)
Cooling water total capacity ℓ (Imp qt)			Approx. 8.7 (7-5/8)

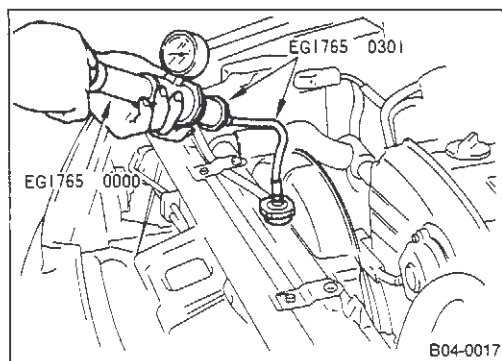

1. Radiator Inspection

Cooling water leak inspection

- Use radiator cap tester to apply pressure [limit 98 kPa (1.0 kg/cm², 14 psi)] and check for leakage.

CAUTION:

When using the radiator cap tester, always connect the hose adapter and make sure filler cap is not deformed.

B5 COOLING SYSTEM

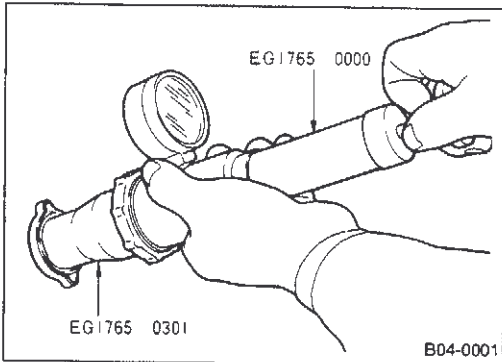

2. Radiator Cap Inspection

Inspection

- Clean cap rubber packing seal surface and vacuum w dry brush.
- Attach radiator cap tester to cap, apply pressure and che that valve operates correctly.

Radiator cap relief pressure	59 - 98 kPa (0.6 - 1.0 kg/cm ² , 9 - 14 psi)
------------------------------	---

- Pull vacuum valve with finger and check operation.

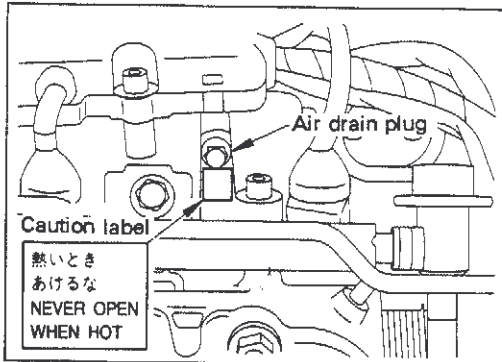

3. Cooling Water Filling Procedures

- ① Make sure the radiator hoses and heater hose clamps a tightened securely.
- ② Set the heater control lever to the "HOT" position. (In vel cles equipped with automatic air conditioners, first tu ignition switch to ON and remove the external sensor co nector.)
- ③ Release the radiator cap and air drain plug.
- ④ Fill the radiator gradually [filling speed: slower than 2 lite (1-3/4 Imp qt)/min] to the top of the spout with coolant. Fill the radiator until the water in the reserve tank reach the "MAX" level indicator.
- ⑤ After closing the radiator cap and air drain plug (F system), start the engine and allow it to idle.
- ⑥ The engine will continue to idle until the thermostat open (Touch the radiator flow hose and make sure hot water flowing). If a large volume of air remains, the water ter perature gauge needle will move past the middle becaus the engine temperature rises abnormally. If this occur stop the engine until it cools and add water to the radiat repeatedly as described above. After the thermostat open race the engine for 10 seconds at 2,500 rpm two or thre times. Check that the water temperature does not ris excessively at this time.
- ⑦ Stop the engine and allow it to cool. Release the radiati cap and check the fluid level. If the fluid level lowers, retui to step ④ and repeat the operation. If the fluid level doe not lower, add water until the reserve tank reaches th "MAX" line.
- ⑧ In vehicles equipped with automatic air conditioning, coi nect the fresh air sensor connector.

B5 COOLING SYSTEM

4. Radiator Removal and Installation

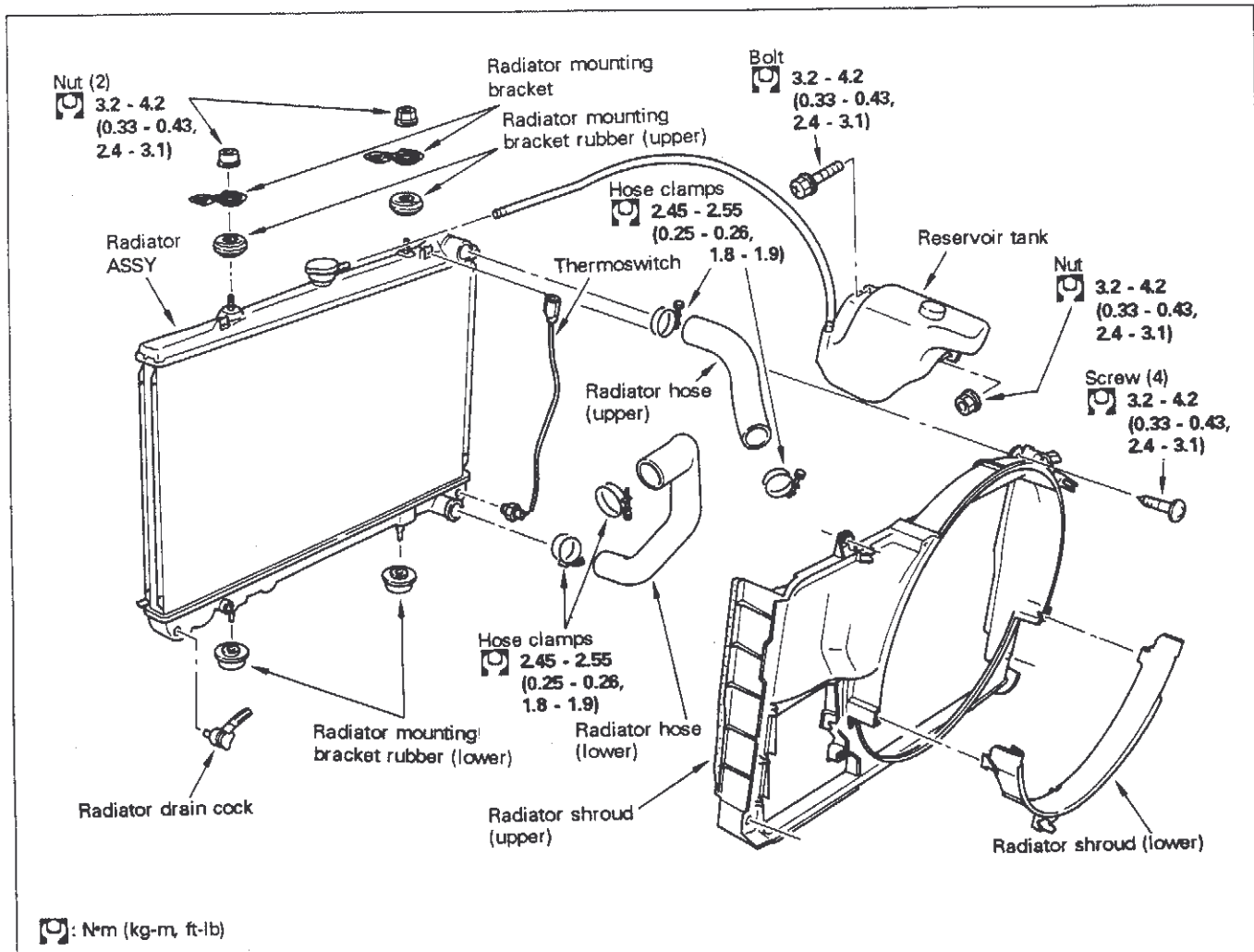

Additional work required:

- Drain and fill: Cooling water
- Remove: Supplementary electrical fan connector

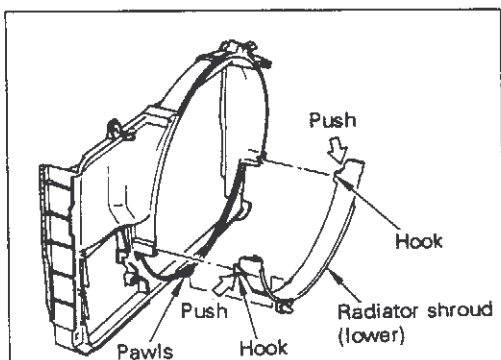

[Point 1] Radiator shroud (lower) removal

- While pushing hooks (left and right, 2 locations) to release, remove pawls and detach shroud.

B5 COOLING SYSTEM

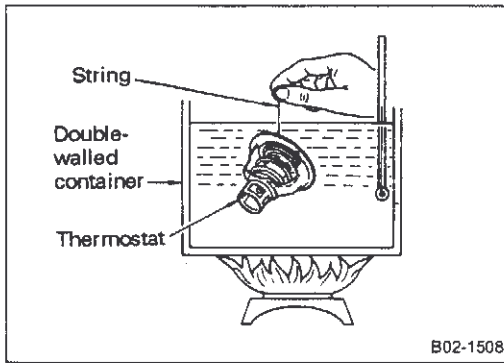

5. Thermostat Inspection

Inspection

- Check that valve opening temperature and maximum valve lift conform to specified value.
- Place a string in thermostat valve and insert in container of water. While holding thermostat heat the water.
- The valve opening temperature is the temperature when the thermostat falls off the string.

Item	Engine	RB26DETT
Valve opening temperature	°C (°F)	76.5 (170)
Maximum valve lift	mm/°C (in/°F)	10 (0.39) minimum/90 (194)

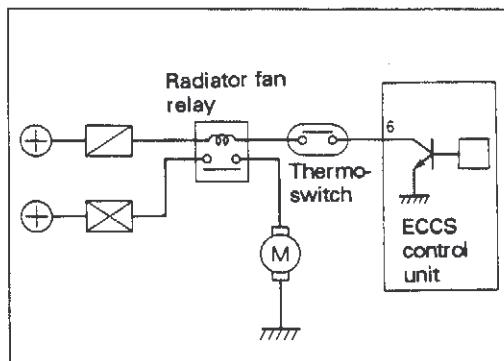

6. Sub Electrical Fan Inspection

Operation

Radiator fan "ON" condition	Thermoswitch "ON" [engine temperature 90°C (194°F) min]
-----------------------------	---

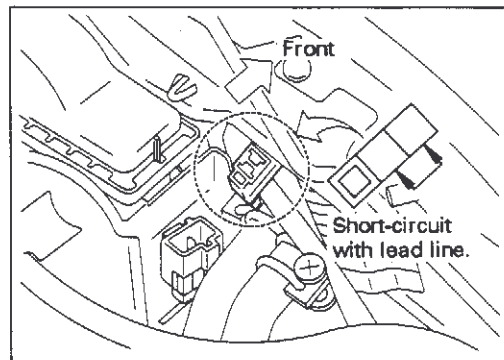

Function inspection

- With ignition switch in OFF position, remove switch harness connectors and short-circuit harness connector.
- With ignition switch in ON position, check that fan motor operates correctly.

Thermoswitch inspection

- Heat thermoswitch with high-temperature water or oil (heat with heat gun, for example) and check if it conforms to values in following chart.

Engine temperature °C (°F)	Valve raised: 90 ± 3 (194 ± 5.4) max. Valve lowered: 83 ± 3 (181 ± 5.4) max.	Valve raised: 90 ± 3 (194 ± 5.4) min. Valve lowered: 83 ± 3 (181 ± 5.4) min.
Thermoswitch connection condition	Non-continuity	Continuity

Thermoswitch tightening torque	3 - 5 N·m (0.3 - 0.5 kg-m, 2.2 - 3.6 ft-lb)
--------------------------------	---

B5 COOLING SYSTEM

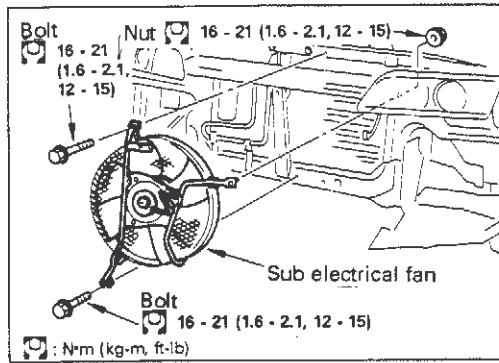

7. Sub Electrical Fan Removal and Installation

Additional work required;

- Remove and install: Intercooler
Harness connectors

B6 FUEL SYSTEM

Preparation tools

	Name	Application
Measurement tool	Circuit tester	Fuel gauge inspection

Specifications

Item		Engine	RB26DETT
Fuel tank main body	Nominal capacity	ℓ (Imp gal)	72 (15-7/8)
	Intake air capacity	ℓ (Imp qt)	5.5 (4-7/8)
	Remaining volume capacity for warning lamp activation	ℓ (Imp qt)	Approx. 13 (11-1/2)
	Warning lamp effective remaining volume	ℓ (Imp qt)	Approx. 12.8 (11-1/4)
	Fuel gauge E indication effective volume	ℓ (Imp qt)	Approx. 8 (7)
	Drain plug		None
Fuel pump			Tank internal electrical system
Filler cap	Type		Screw-in (vacuum relief valve installed)
	Relief valve opening valve pressure	kPa (mmHg, inHg)	-6.0 to -3.3 (-45 to -25, -1.77 to -0.98)
Fuel overflow prevention system			Internal air chamber system (check valve attached)
Reservoir tank capacity		ℓ (Imp qt)	—
Fuel gauge unit	Gauge system		Float arm system
	Resistance value	Ω F	Approx. 6
		E	Approx. 80
Remaining volume warning system			Thermistor system
Evaporation system			Canister system
Fuel tube diameter	Outlet	mm (in)	8 (0.31)
	Return	mm (in)	8 (0.31)

B6 FUEL SYSTEM

1. Fuel Tank Removal and Installation

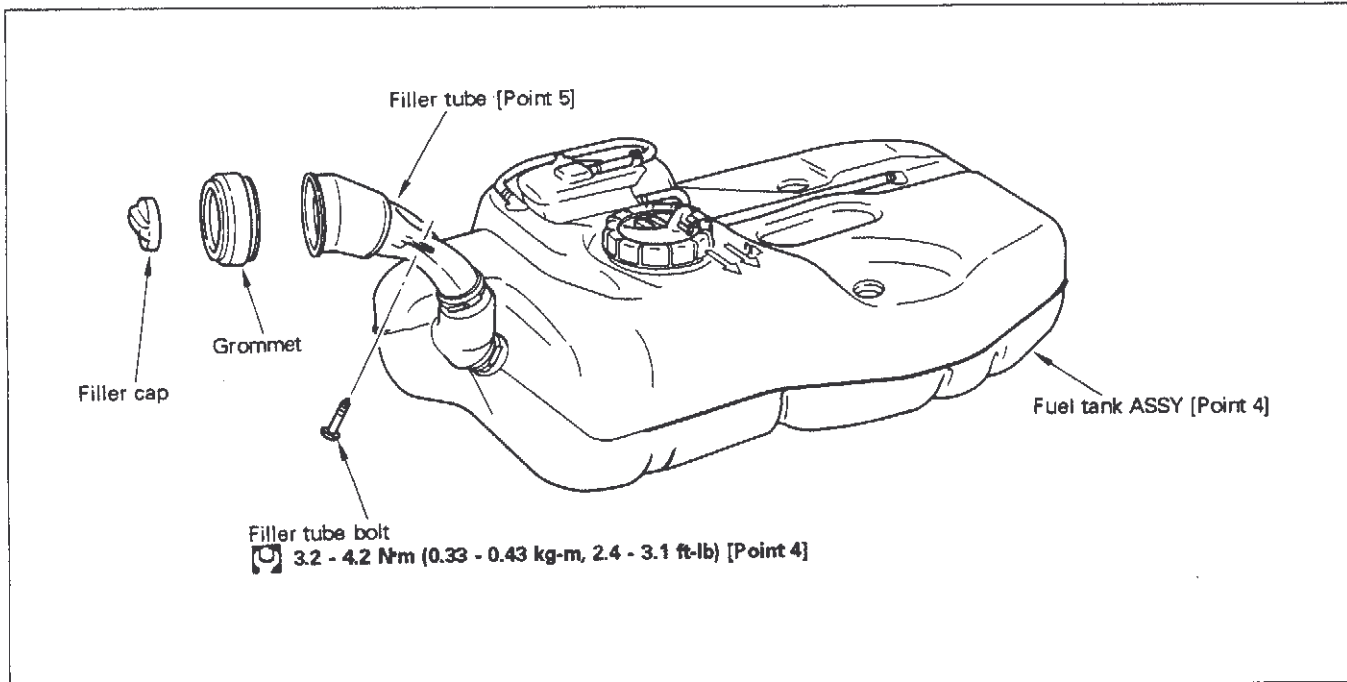

Additional work required:

- Drain: Fuel
- Remove: Fuel pressure relief valve [Point 1]
Fuel tank internal pressure relief
Filler tube protector
Inspection hole cover [Point 2]
Fuel gauge unit, fuel pump harness connector [Point 3]
Fuel tank protector
Hoses

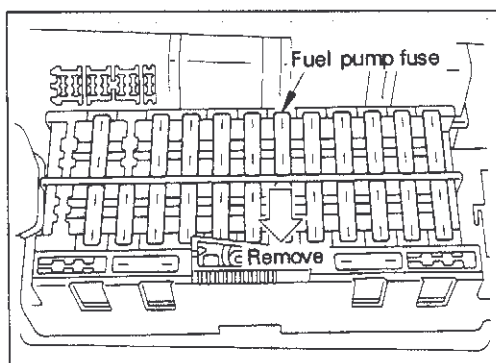

[Point 1] Fuel pressure relief

- After starting engine, remove fuel pump fuse and wait until engine stops. Crank engine 2-3 times to consume fuel in lines.
- In vehicles which cannot be started, remove fuel pump fuse, crank engine 4-5 times to consume fuel in lines.

CAUTION:

The battery may become weak easily, so use booster cables to connect it to another vehicle or battery if necessary.

B6 FUEL SYSTEM

1. Fuel Tank Removal and Installation (Cont'd)

[Point 2] Inspection hole cover removal and installation

Removal

- Remove the trunk floor carpet and detach the inspector hole cover.

Installation

- Check that fuel gauge unit and fuel pump harness connectors are connected securely.
- Check that fuel hose connections are secure.

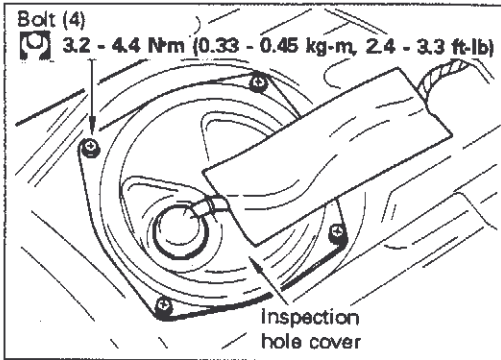

Bolt tightening torque	3.2 - 4.4 N·m (0.33 - 0.45 kg-m, 2.4 - 3.3 ft-lb)
------------------------	---

[Point 3] Fuel gauge unit, fuel pump harness connector removal

- Remove inspection hole cover. Detach fuel gauge unit and fuel pump harness connector.

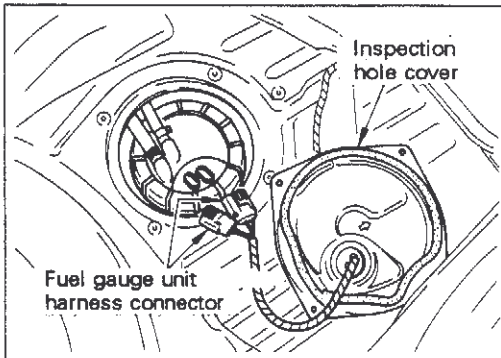

[Point 4] Fuel tank removal and installation

Removal

- Remove feeler tube protector, and detach bolt shown in figure on left.
- Remove feeler tube grommet from body.
- Remove fuel tank protector, fuel tank band mount bolts and detach fuel tank.

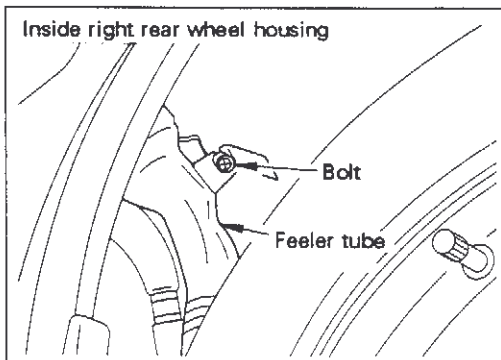

Installation

- Attach tank and secure by tightening mount bolt on front side of right member to specified torque.

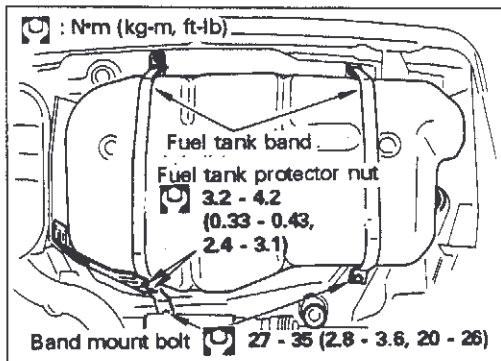

Band mount bolt tightening torque	27 - 35 N·m (2.8 - 3.6 kg-m, 20 - 26 ft-lb)
Protector nut tightening torque	3.2 - 4.2 N·m (0.33 - 0.43 kg-m, 2.4 - 3.1 ft-lb)

[Point 5] Filler tube installation

- Insert spacer between fuel tank and filler tube and connect tube. Tighten clamps securely.
- Tighten filler tube grommets to body.

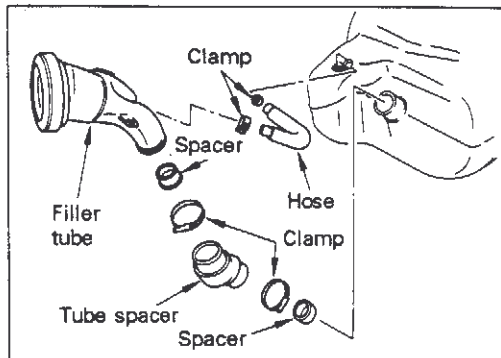

B6 FUEL SYSTEM

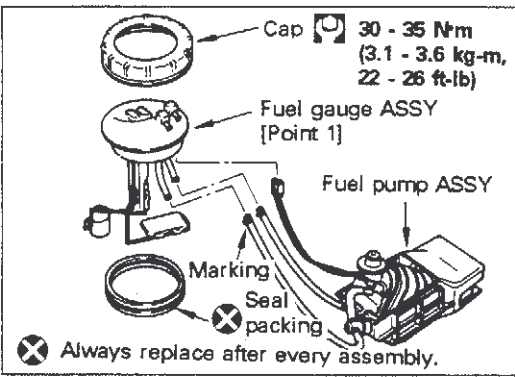

2. Fuel Gauge ASSY

(1) Fuel gauge ASSY removal and installation

Additional work required:

- Remove: Fuel pressure relief, internal pressure relief
Inspection hole cover
Fuel gauge unit
Fuel pump harness connector
Fuel hose (return, feed)

CAUTION:

- Install gauge unit with care.
- Do not touch float and arm to prevent them from bending.
- Do not bend or twist harness.

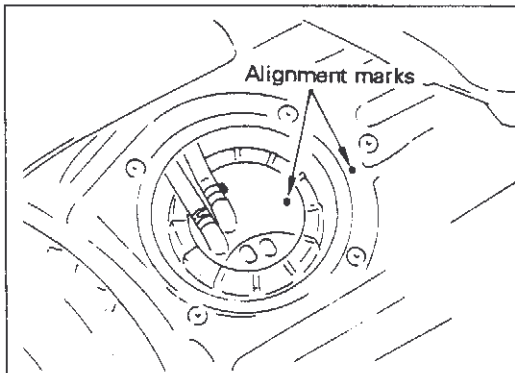

[Point 1] Fuel gauge ASSY removal and installation

Removal

- Attach alignment marks to the fuel gauge ASSY and fuel tank and then remove the cap.
- Raise fuel gauge ASSY, remove 2 hoses in tank (marked section is outlet side), fuel pump harness connector and detach fuel gauge ASSY.

CAUTION:

Be especially careful not to damage fuel gauge ASSY.

Installation

- Check marking on hose inside tank and connect fuel gauge ASSY.
- Check that fuel gauge ASSY and fuel tank alignment marks are positioned correctly and tighten cap.

Tightening torque	30 - 35 N·m (3.1 - 3.6 kg-m, 22 - 26 ft-lb)
-------------------	--

B6 FUEL SYSTEM

2. Fuel Gauge ASSY (Cont'd)

(2) Fuel gauge ASSY inspection

① Float inspection

- Place the float at the F (lever upper side) and E (lever down side) positions and check the resistance.

Float position	F position	E position
Inspection terminal		
④ - ⑤	Approx. 6Ω	Approx. 80Ω

② Low fuel warning lamp sensor inspection

- Connect a 12V - 3.4 W test lamp or equivalent.

- Wash sensor with gasoline or white gasoline and check that lamp does not light after approximately 3 minutes have elapsed.
- Remove sensor from gasoline or white gasoline and check that lamp lights within 3 minutes.

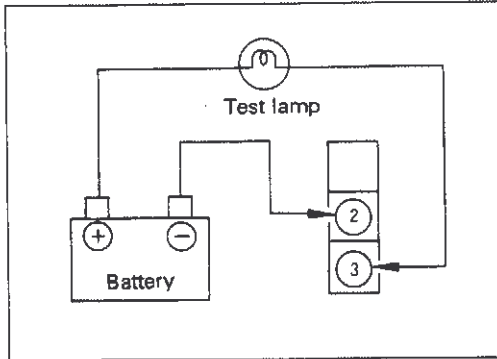
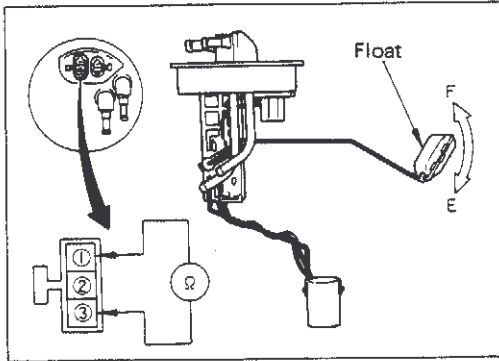

3. Fuel Pump Removal and Installation

(1) Fuel pump disassembly

Additional work required:

- Remove: Fuel pressure relief, internal pressure relief
Fuel gauge

CAUTION:

- Be careful when handling fuel pump.
- Do not use pump again if it is dropped.
- Do not allow dirt or debris to adhere to the filter.
- Do not twist or turn harness.

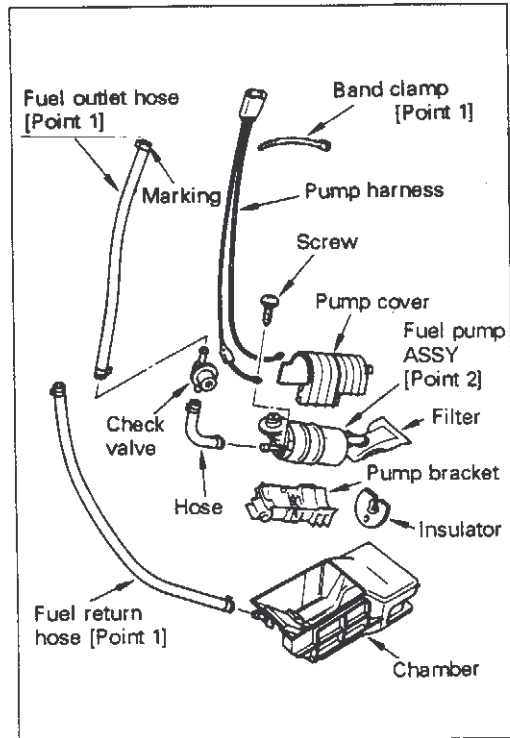

B6 FUEL SYSTEM

3. Fuel Pump Removal and Installation (Cont'd)

[Point 1] Fuel hose removal and installation

Removal

- Raise fuel gauge ASSY, remove 2 hoses in tank (marked section is outlet side), fuel pump harness connector and detach fuel gauge ASSY.

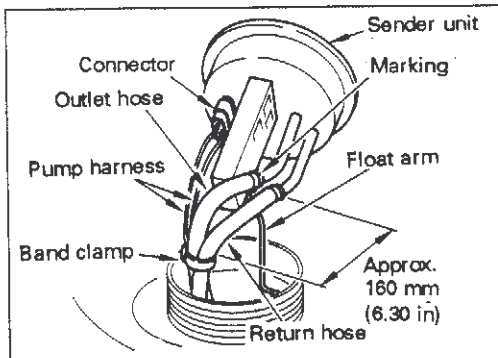

Installation

- Check fuel hose marking, connect fuel gauge ASSY. Position pump harness and clamp band 160 mm (6.30 in) from gauge ASSY connecting part and tighten securely.
- Be careful that fuel hose and fuel harness turn inside tank from the right to front side of vehicle and do not cause any interference with float arm.

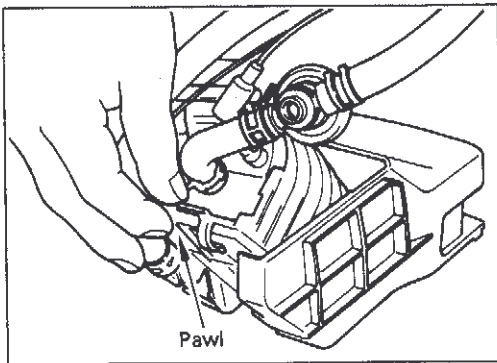

[Point 2] Fuel pump removal and installation

Removal

- Push the pawl lightly on rear side of pump bracket, and remove fuel pump in pump rotation direction.

CAUTION:

The fuel return hose must not be removed.

Installation

- Insert fuel pump in fuel chamber and attach pawl on rear side of pump bracket in retaining notch inside fuel chamber. Insert pump in axial direction.

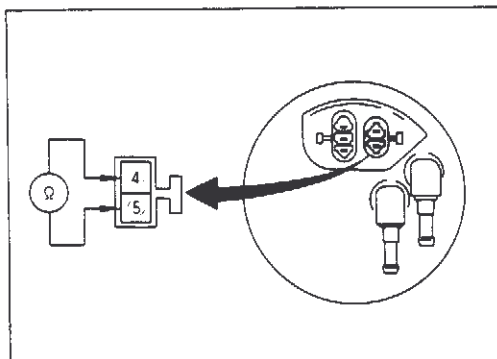

(2) Fuel pump inspection

Inspection

- Apply voltage from the battery to harness connectors terminals ④ and ⑤ to check pump operation.

B7 EXHAUST SYSTEM

Specifications

Item		Engine	RB26DETT
Front tube	Tube outer diameter mm (in)	Dual portion	54 (2.13)
		Single portion	70 (2.76)
	Long dual tube		—
	Flexible tube		Installed
	Pre-muffler	[capacity ℓ (Imp qt)]	—
Muffler ASSY	Center tube outer diameter	mm (in)	70 (2.76)
	Pre-muffler	[capacity ℓ (Imp qt)]	Installed [7.0 (6-1/8)]
	Flexible tube		—
	Dynamic damper		Installed
	Main muffler capacity	ℓ (Imp gal)	16 (3-1/2)
	Tail pipe external diameter	mm (in)	59 × 83 (2.32 × 3.27) (ellipse)
Catalytic converter	Types		Under body floor, three-way, single-unit
	Capacity	ℓ (Imp qt)	1.7 (1-1/2)
	Catalytic metal		Platinum rhodium
Exhaust gas temperature warning equipment operation temperature		°C (°F)	850 (1,562)

Exhaust system part inspection, warning precautions

- The heat resistance and corrosion resistance in exhaust system parts and component shape have been carefully considered in the design process, so only use genuine Nissan parts for replacement.
- Clean each connection part and connect securely, making sure there are no gas leaks.
- Always use new gaskets in the front and rear of catalytic converter.
- Always use new parts for exhaust manifold connection gasket and nuts.
- After assembling each part, warm engine, raise speed to 2,000 to 3,000 rpm and make sure there are no gas leaks, sealing compound leaks or sealing gaps.
- Replace parts rather than repairing extreme deformation in heat insulation panels. If extreme amounts of dirt have accumulated, clean these areas.
- When attaching heat insulation panels, make sure there is adequate clearance and no interference between exhaust pipes.

B7 EXHAUST SYSTEM

1. Exhaust Pipe, Catalytic Converter and Heat Panel Tightening Torques

(1) RB26DETT (4WD)

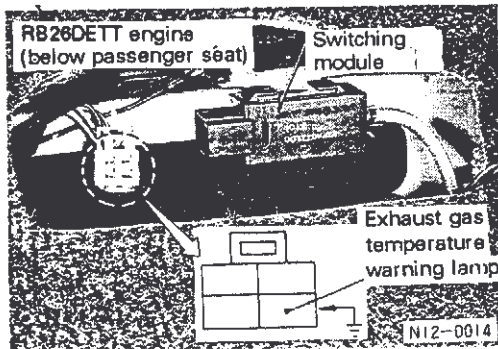
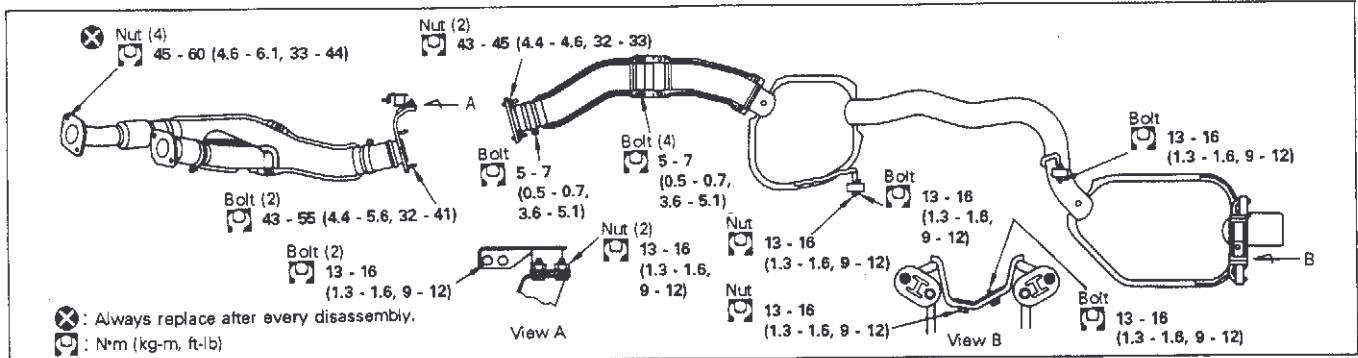

2. Exhaust Gas Temperature Warning Equipment Inspection

Basic inspection

- Turn ignition key ON and check that exhaust gas temperature warning lamp does not light.
- Exhaust gas temperature warning lamp must light when ignition is at START and must go off when engine starts.

Exhaust gas temperature warning lamp replacement and inspection

- Remove vehicle harness from switching module.
- Use lead line to ground vehicle side harness connector exhaust gas temperature warning lamp terminal.
- Inspect condition of exhaust gas temperature warning lamp with ignition switch turned ON.

Lamp lights	<ul style="list-style-type: none"> ● Faulty circuit between ignition switching module ● Faulty key sensing module or sensor
Lamp does not light	<ul style="list-style-type: none"> ● Exhaust gas temperature warning lamp is burned out. ● Exhaust gas temperature warning lamp power circuit is faulty.

B8 ENGINE CONTROL

1. Accelerator Pedal Inspection and Adjustment

Accelerator pedal inspection

- The engine must be at full throttle when accelerator pedal is pressed down fully (pedal lever contacts the stopper completely).

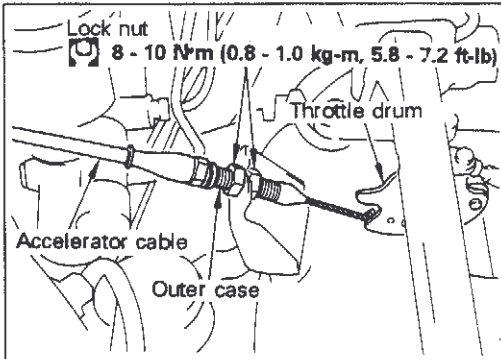

Accelerator pedal adjustment

- Loosen lock nuts so accelerator cable has adequate slack. Pull outer case in direction of accelerator pedal from position where throttle drum starts operating (there must be no play at this point), return lock nuts 1.0 to 1.5 turns and tighten securely.

Tightening torque	8 - 10 N·m (0.8 - 1.0 kg-m, 5.8 - 7.2 ft-lb)
-------------------	--

B9 ENGINE MOUNTING (4WD)

1. Front Engine Mounting (RB26DETT)

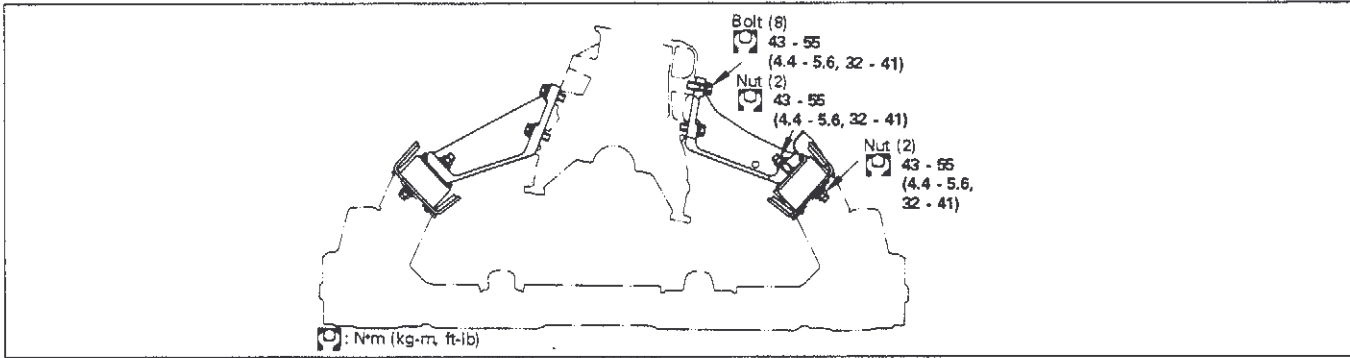

2. Rear Engine Mounting (RB26DETT)

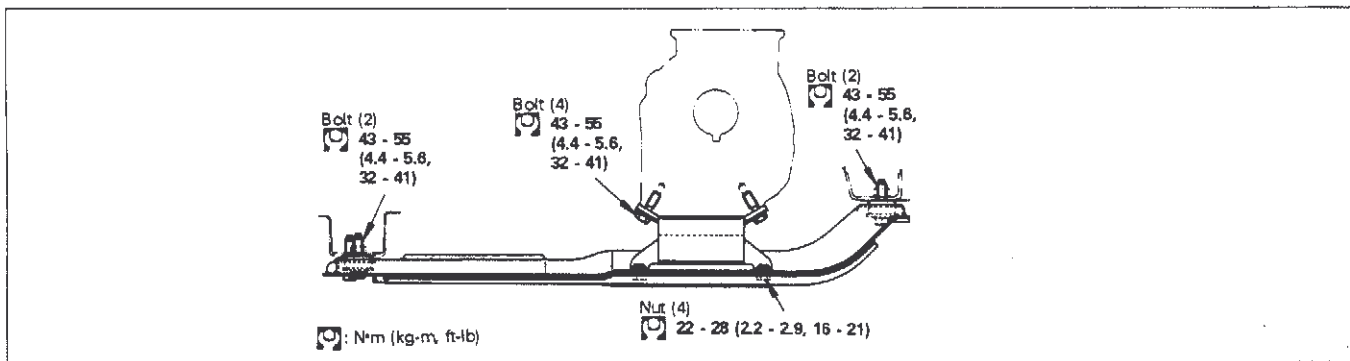

CHASSIS

SECTION CH

CONTENTS

C1 CLUTCH	C- 3
1. Summary	C- 4
2. On-vehicle Inspection and Adjustment	C- 5
3. Component Parts Removal and Installation, Assembly and Disassembly	C- 7
C2 MANUAL TRANSMISSION	C- 18
1. Summary	C- 23
2. On-vehicle Inspection and Adjustment	C- 26
3. Transmission Removal and Installation, Assembly and Disassembly	C- 26
C3 ELECTRICAL CONTROL TORQUE SPLIT 4WD SYSTEM (ATTESSA E-TS)	C- 57
1. Summary	C- 59
2. On-vehicle Inspection and Adjustment	C- 61
3. Troubleshooting	C- 66
4. Removal and Installation, Assembly and Disassembly	C- 79
C4 PROPELLER SHAFT	C-114
1. Summary	C-114
2. On-vehicle Inspection	C-115
3. Propeller Shaft Removal and Installation, Assembly and Disassembly	C-116
C5 FINAL DRIVE	C-120
1. Summary	C-125
2. On-vehicle Inspection and Preparation	C-130
3. Final Drive Removal and Installation, Assembly and Disassembly	C-135
C6 DRIVE SHAFT	C-194
1. Summary	C-194
2. On-vehicle Inspection	C-195
3. Drive Shaft Removal and Installation, Assembly and Disassembly	C-196
C7 FRONT SUSPENSION AND AXLE	C-209
1. Summary	C-212
2. On-vehicle Inspection and Preparation	C-213
3. Part Removal and Installation, Assembly and Disassembly	C-218
C8 REAR SUSPENSION AND AXLE	C-229
1. Summary	C-229
2. On-vehicle Inspection and Preparation	C-230
3. Removal and Installation, Assembly and Disassembly	C-233





C9 WHEELS AND TIRES	C-243
1. Summary	C-243
2. Wheels	C-243
3. Tires	C-245
C10 BRAKES	C-246
1. Summary	C-247
2. On-vehicle Inspection	C-249
3. Trouble Diagnosis (Anti-Lock Braking system).....	C-257
4. Removal and Installation, Assembly and Disassembly	C-267
C11 STEERING	C-291
1. Summary	C-294
2. On-vehicle Inspection and Adjustment	C-296
3. Control Unit Trouble Diagnosis	C-310
4. Removal and Installation Assembly and Disassembly	C-315
C12 SUPER HICAS	C-334
1. Summary	C-335
2. On-vehicle Inspection and Adjustment	C-337
3. Trouble Diagnoses	C-343
4. Removal and Installation, Assembly and Disassembly	C-364

C1 CLUTCH

OPERATION PRECAUTIONS

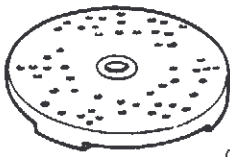
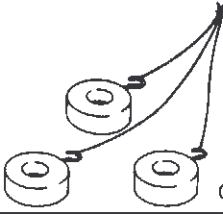
- Use genuine Nissan brake fluid NR-3 (No. 2500) for the clutch fluid.
- Never use the clutch fluid a second time.
- Do not allow clutch fluid to contact external painted surfaces of other equipment.
- Use special service tool (CG9431 0000) for the clutch tube installation.
- Use clean clutch fluid to clean the parts such as master cylinder, operating cylinder and tubes.
- Never use gasoline or solvents because they may damage rubber parts.

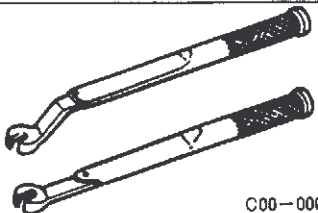
SPECIAL SERVICE TOOLS

Tool name Tool number	Description	
Base plate ST2005 0010	 C00-0026	Clutch cover inspection
Distance piece ST2005 0100	 C00-0027	Same as above
Diaphragm adjustment wrench ST2005 0204	 C00-0028	Same as above
Diaphragm nut torque wrench GG9431 0000	 C00-0002	Clutch pipe installation
Vacuum hand pump EG15130 0000	 C00-0053	Clutch booster and check valve inspection

C1 CLUTCH

1. Summary

Description		Engine	RB26DETT
Clutch cover	Model		C240S
	Installation weight	kg (lb)	750 (1,654)
Clutch disk	Model		240TBL
	Facing material		NN63
	Torsional characteristic		1 level
Master cylinder size	Inner diameter mm (in)		15.87 (5/8)
Operating cylinder size	Inner diameter mm (in)		19.05 (3/4)
Separation pipe			Attached
Thrust spring			—
Assist spring			Attached
Clutch release bearing adjustment core type			Non-self-aligning core
Master-Vac.	Booster	Model	CM19C
		Diaphragm inner diameter mm (in)	78.7 (3.098)

Inspection reference values

Description		Engine	RB26DETT
Pedal	Pedal height		171.7 - 181.7 (6.76 - 7.15)
	Pedal play (clevis play)		5 - 12 (0.20 - 0.47) [1 - 3 (0.04 - 0.12)]
	Clearance from floor when fully depressed		81 (3.19)
Disk	Model		240TBL
	Wear limit (rivet head depth)		0.3 (0.012)
	Diameter runout limit		1.0/230 (0.039/9.06)
Cover	Model		C240S
	Diaphragm spring lever height		37.5 - 39.5 (1.476 - 1.555)
	Diaphragm spring unevenness limit		0.5 (0.020) max.
Booster vacuum leak [Vacuum; 66.7 kPa (500 mmHg, 19.69 inHg)]		kPa (mmHg, inHg)	3.3 (25, 0.98) max. in 15 seconds
Check valve load leak [Vacuum; 66.7 kPa (500 mmHg, 19.69 inHg)]		kPa (mmHg, inHg)	1.3 (10, 0.39) max. in 15 seconds

C1 CLUTCH

2. On-vehicle Inspection and Adjustment

2-1 CLUTCH PEDAL ADJUSTMENT

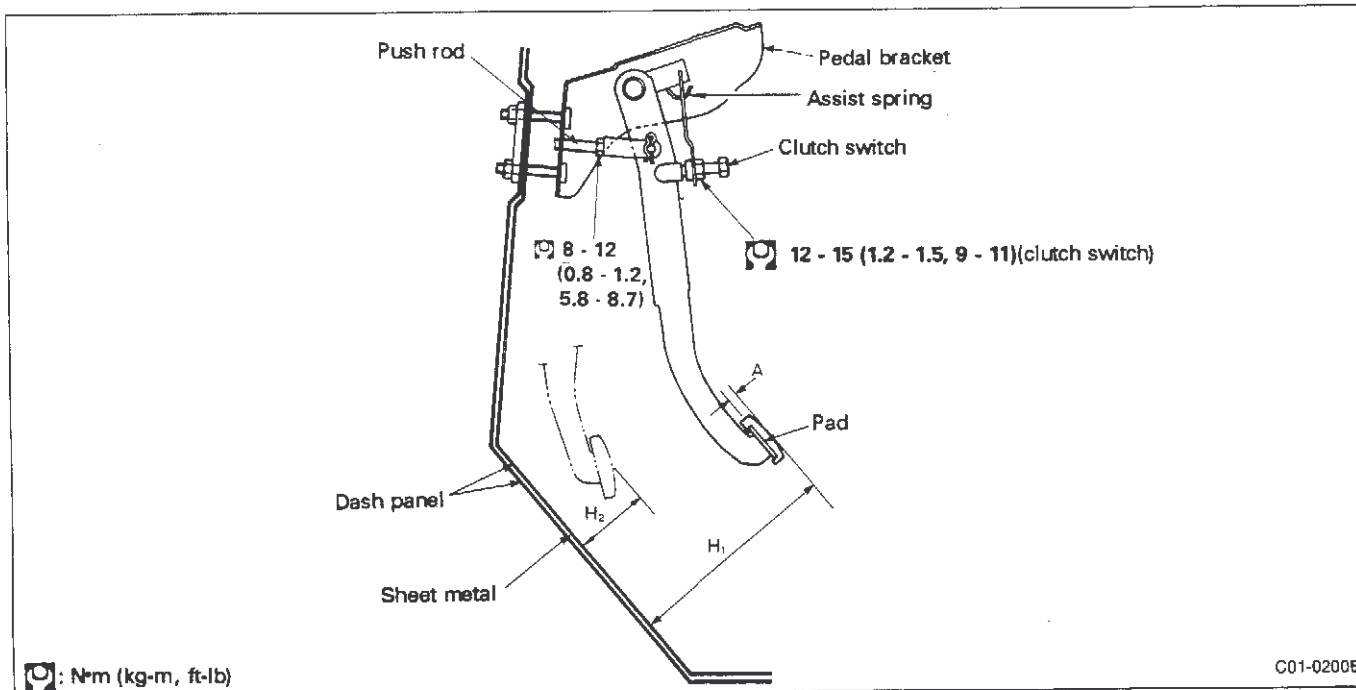

Adjustment

- Adjust the pedal height (H) with pedal stopper.
- Adjust the pedal free play (A) with master cylinder push rod. Then tighten lock nut.

Unit: mm (in)

Description	Engine	RB26DETT
Pedal height: H ₁ (from clevis)		171.5 - 181.7 (6.75 - 7.15)
Play from pedal pad center: A [clevis play]		5 - 12 (0.20 - 0.47) [1 - 3 (0.04 - 0.12)]
Clearance from floor when fully depressed: H ₂		81 (3.19)

2-2 AIR BLEEDING

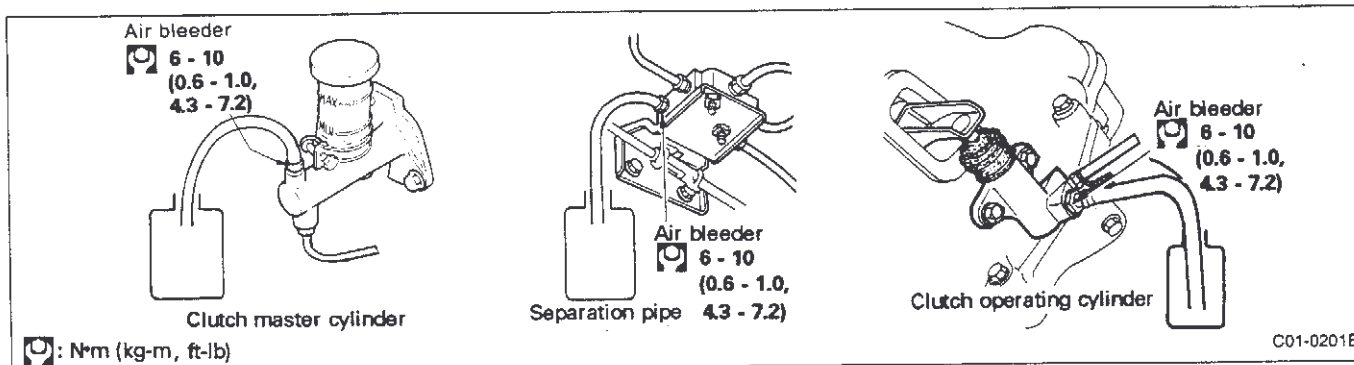

For vehicles equipped with separation pipe, bleed the separation pipe first and then bleed operating cylinder.

C1 CLUTCH

2. On-vehicle Inspection and Adjustment (Cont'd)

Bleeding procedure

1. Top up master cylinder reservoir with recommended brake fluid.
2. Connect a transparent vinyl tube to air bleeder valve.
3. Fully depress clutch pedal several times.
4. With clutch pedal depressed, open bleeder valve to release air.
5. Close bleeder valve.
6. Repeat steps 3 through 5 above until clear brake fluid without bubbles comes out of air bleeder valve.

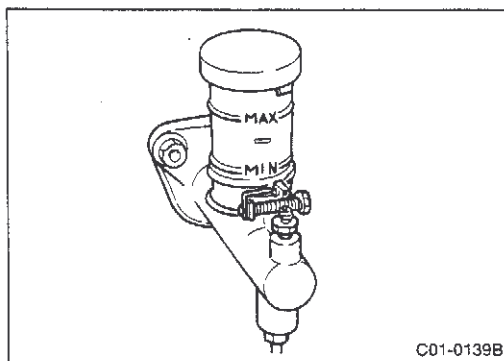

2-3 CLUTCH FLUID INSPECTION

- Check that clutch fluid is between MAX-MIN levels of reservoir tank.
- Make sure there are no leaks around reservoir tank.

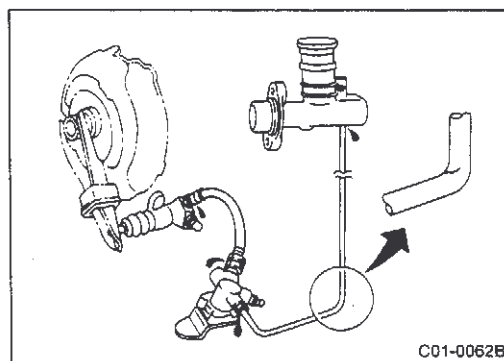

2-4 LEAKING, DAMAGE AND INSTALLATION INSPECTION

Check the following items.

- Check hoses, tubes and connections for leakage, damage, twisting and deformations.
- Check that there are no leaks from any part when clutch pedal is pressed.

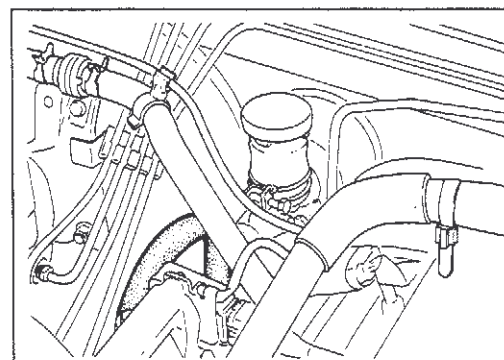

2-5 VACUUM PIPE INSPECTION (vehicles equipped with RB26DETT)

- Check hose tube and connections for leaking, twisting and deformations.
- Check that clamps and connections are not loose.
- Check that Arrow on E-mark of check valve is positioned facing the engine side.

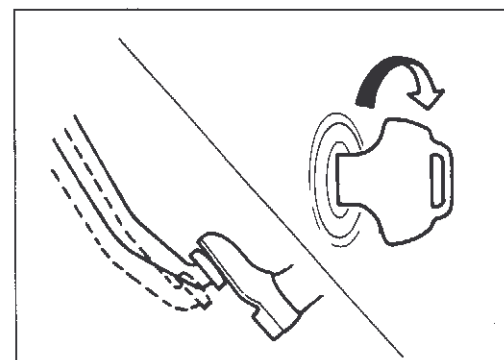

2-6 BOOSTER FUNCTION INSPECTION (vehicles equipped with RB26DETT engine)

Procedures

1. Let engine idle approx. 1 minute, apply load to booster and turn ignition switch OFF.
2. When engine is stopped, press clutch pedal several times. After making sure pressure changes, continue pressing clutch pedal down and start engine. Check if there is any change in pedal pressure. (A change in pressure is normal.)

C1 CLUTCH

2. On-vehicle Inspection and Adjustment (Cont'd)

2-7 BOOSTER SEALING INSPECTION (vehicles equipped with RB26DETT engine)

- Connect the hand vacuum pump (special service tool) as shown in the figure and perform measurement.

Measurement value:

Maximum decrease of 3.3 kPa (25 mmHg, 0.98 inHg) within 15 sec from initial pressure of -66.7 kPa (-500 mmHg, -19.60 inHg).

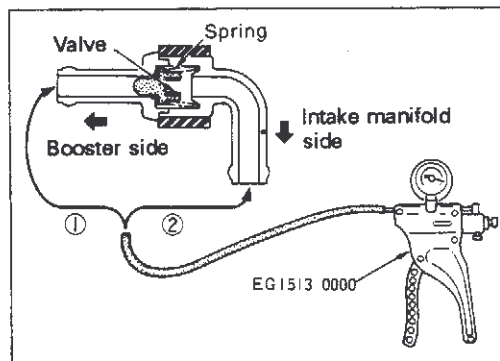
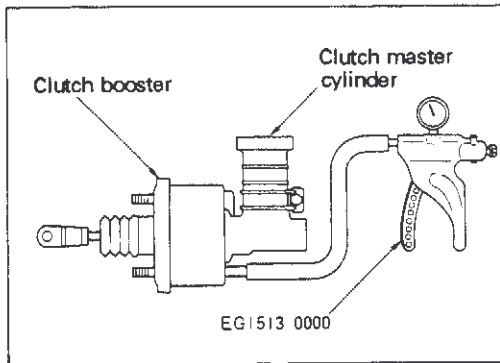

2-8 CHECK VALVE INSPECTION (RB26DETT engine)

- Use a vacuum pump (special service tool) to perform the inspection.

Attached to booster side (1)	Maximum decrease of 1.3 kPa (10 mmHg, 0.39 inHg) within 15 sec from initial vacuum pressure of -66.7 kPa (-500 mmHg, -19.69 inHg).
Attached to engine (2)	No load is applied.

3. Component Parts Removal and Installation, Assembly and Disassembly

3-1 CLUTCH PIPING REMOVAL AND INSTALLATION

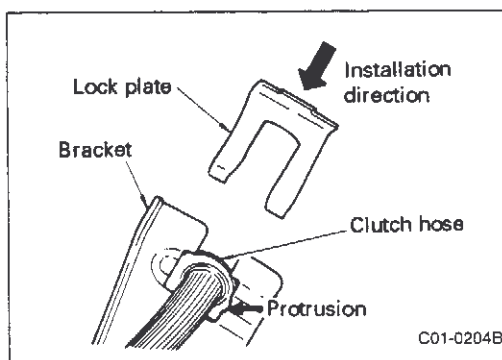
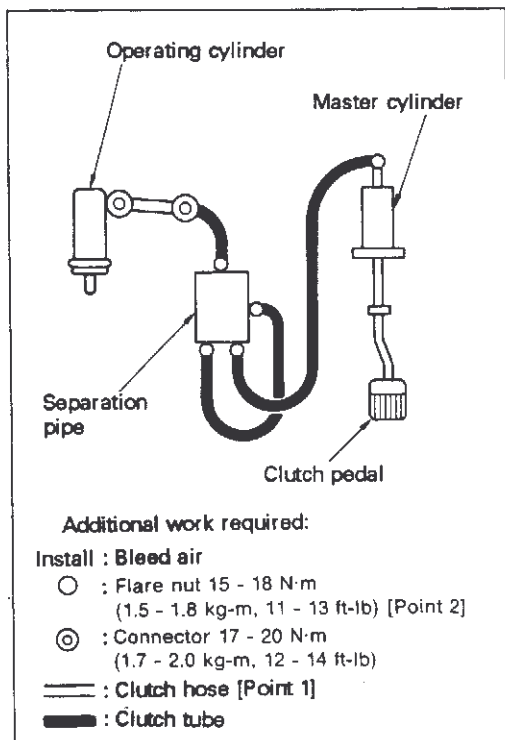

[Point 1] Clutch hose installation

- Install hose from cylinder body. Position plate as shown in the figure and secure.

CAUTION:

- (1) The hose and hose bracket must be aligned and with protrusion and assembled as shown in figure.
- (2) After assembly, make sure the hose is not twisted, or bent and does not interfere with other parts.

C1 CLUTCH

3. Component Parts Removal and Installation, Assembly and Disassembly (Cont'd)

[Point 2] Flare nut removal and installation

- Use a flare nut wrench to remove flare nuts. Use a flare nut torque wrench (special service tool) for installation. Be careful not to damage flare nut or clutch tube.

Flare nut tightening torque:

15 - 18 N·m (1.5 - 1.8 kg-m, 11 - 13 ft - lb)

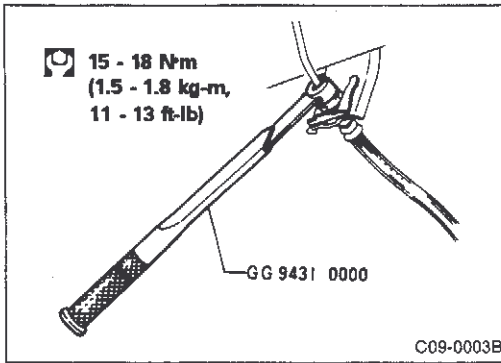

3-2 Separation pipe removal and installation

Removal

- Use a flare nut wrench to remove clutch tube piping. Next remove bracket bolt.

Installation

- Tighten bracket to torques shown in figure.
- Use flare nut torque wrench (special service tool) to tighten clutch tube piping to specified torque.

CAUTION:

Always bleed air from system after installation.

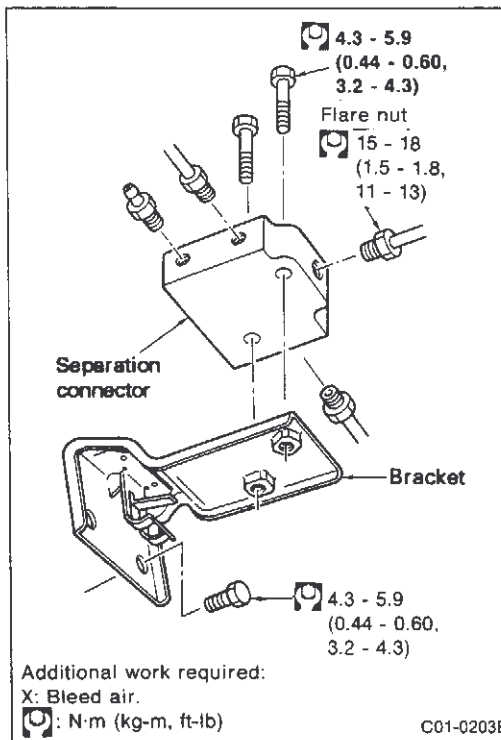

C1 CLUTCH

3. Component Parts Removal and Installation, Assembly and Disassembly (Cont'd)

3-3 BOOSTER AND VACUUM PIPING REMOVAL AND INSTALLATION

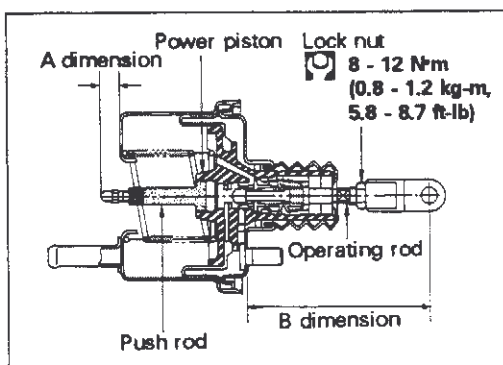
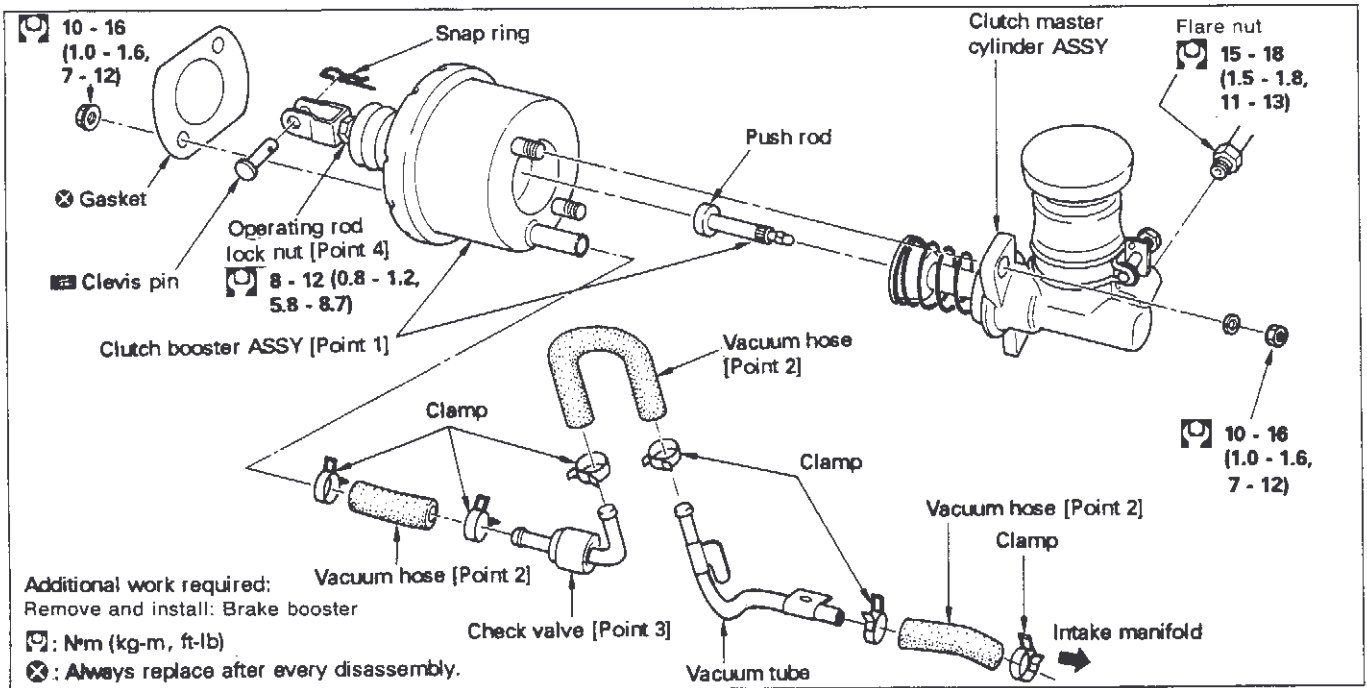

[Point 1] Booster removal and installation

CAUTION:

Disassemble booster from master cylinder. Do not allow booster operating rod to make a stroke.

- Be careful not to scratch reservoir tank and body during removal and installation.
- When installing master cylinder in booster, make sure push rod is installed in power piston as shown in figure. Check that dimension A in figure conforms to specified values indicated below and then install master cylinder.

CAUTION:

To prevent booster push rod from being pressed in, position unit so rod faces up and then install master cylinder.

A dimension standard value:

9.6 mm (0.378 in)

- Loosen operating rod lock nut and adjust operating rod so B dimension conforms to specified length.

B dimension standard value:

94 mm (3.70 in)

- After adjusting operating rod to standard value, tighten lock nut temporarily. After unit is installed, adjust pedal height and tighten lock nut to specified torque.

C1 CLUTCH

3. Component Parts Removal and Installation, Assembly and Disassembly (Cont'd)

- Always bleed air from system after master cylinder is removed or to complete installation.

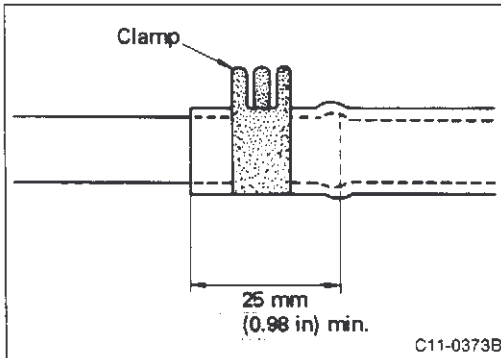

[Point 2] Vacuum hose assembly

- Insert more than 25 mm (0.98 in) of the hose.
- Do not use lubrication oil during assembly.

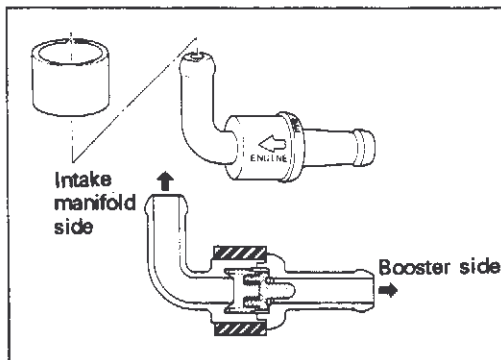

[Point 3] Check valve assembly

- Position the check valve so valves faces engine (vacuum pump) in the direction of the arrow shown in figure.

C1 CLUTCH

3. Component Parts Removal and Installation, Assembly and Disassembly (Cont'd)

3-4 MASTER CYLINDER ASSEMBLY AND DISASSEMBLY

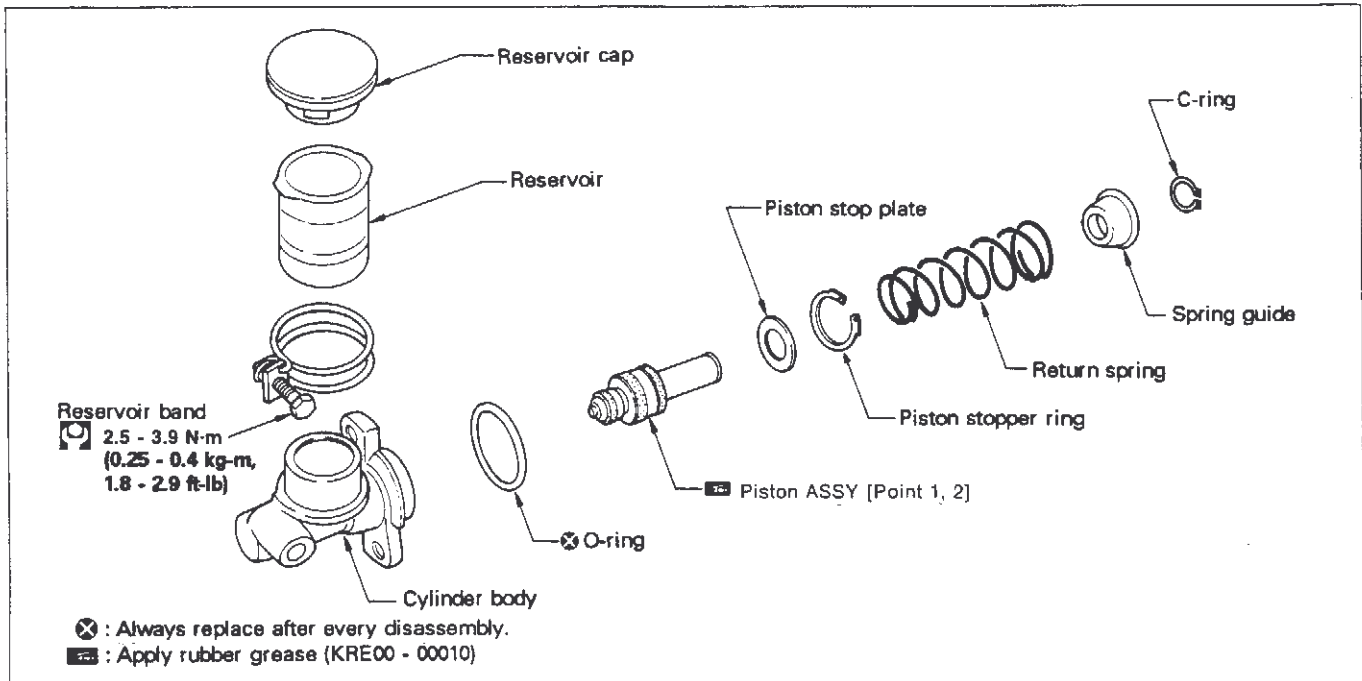

[Point 1] Piston ASSY removal

- Remove the C-ring. Press the spring guide to prevent the spring from flying out and remove the piston ASSY.

[Point 2] Piston ASSY installation

- The piston cup must be exchanged with the piston ASSY.

CAUTION:

- (1) Apply a thin coat of Nissan rubber grease to the sliding part of the cylinder piston and cap. (Only use genuine Nissan products.)
- (2) Check direction of piston cup before assembly.

[Point 3] Part inspection

- Check the following items and replace as necessary.
- Rubbing surface of cylinder head and piston for uneven wear, rust or damage
- Piston and piston cup, for wear or damage.
- Return spring, for wear or damage.
- Reservoir tank wear or damage

C1 CLUTCH

3. Component Parts Removal and Installation, Assembly and Disassembly (Cont'd)

3-5 OPERATING CYLINDER REMOVAL AND INSTALLATION, ASSEMBLY AND DISASSEMBLY

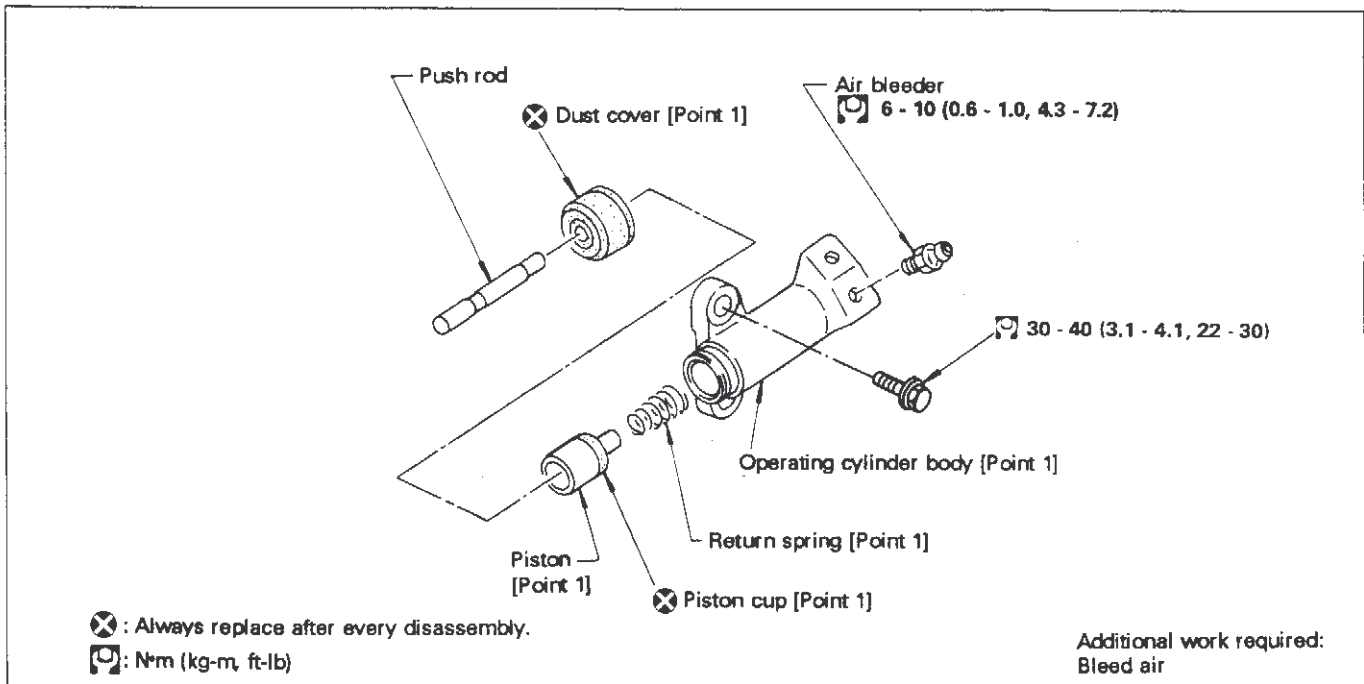

[Point 1] Part inspection

Inspect the following parts and replace as necessary.

- Piston and piston cup for wear, damage or deterioration.
- Piston springs, for wear or damage.
- Check dust cover for cracks, deformation or damage.
- Check inner cylinder for scratches or foreign matter.

C1 CLUTCH

3. Component Parts Removal and Installation, Assembly and Disassembly (Cont'd)

3-6 CLUTCH PEDAL REMOVAL AND INSTALLATION, ASSEMBLY AND DISASSEMBLY

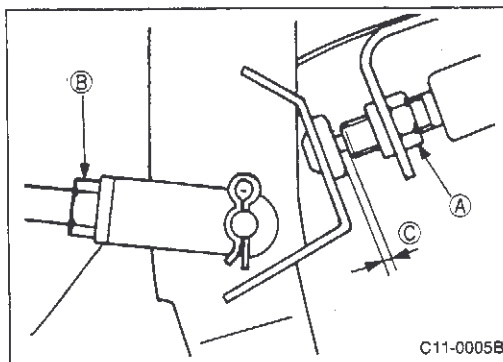
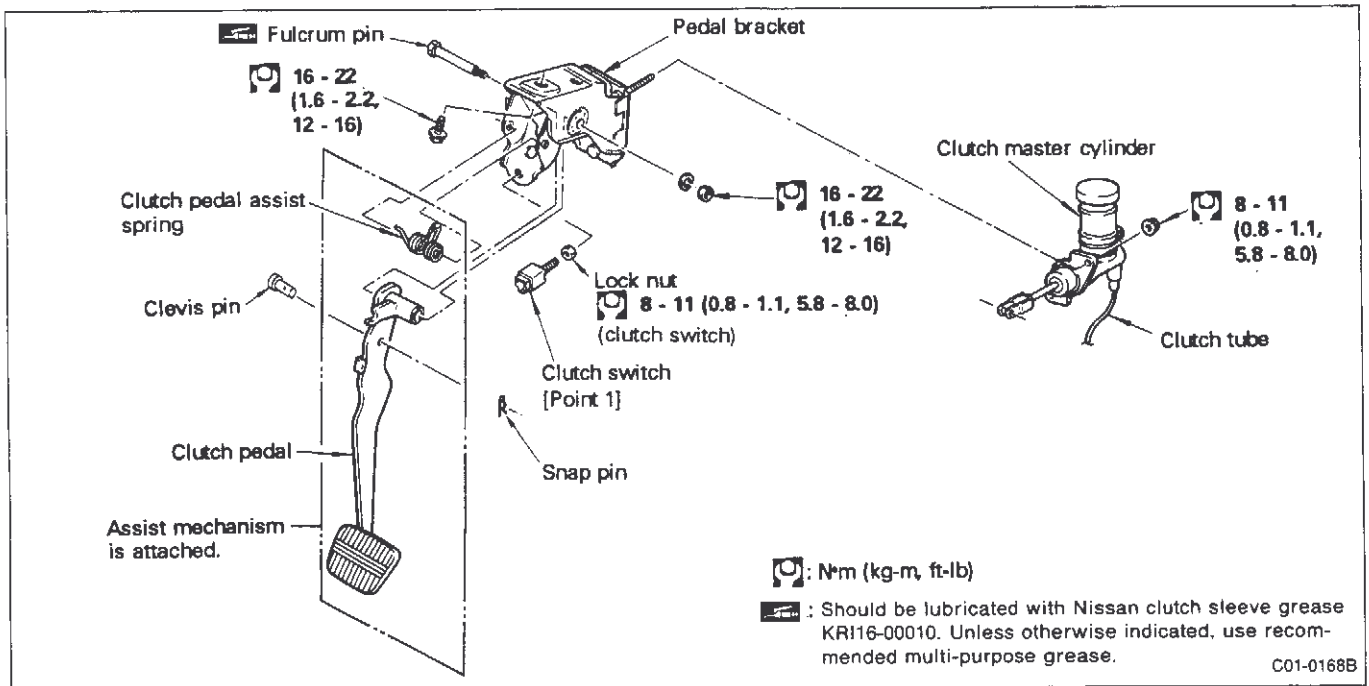

[Point 1] Clutch switch adjustment (for vehicles equipped with ASCD and SUPER HICAS)

1. Loosen clutch switch lock nut **(A)**.
2. Loosen push rod lock nut **(B)** and turn push rod. Adjust pedal to specified height and tighten lock nut.
3. Turn the switch so there is a clearance of 0.3 to 1.0 mm (0.012 to 0.039 in) between stopper rubber and end of clutch switch screw. Tighten lock nut to specified torque.

Lock nut tightening torque	N·m (kg-m, ft-lb)	(A) 12 - 15 (1.2 - 1.5, 9 - 11)
		(B) 8 - 12 (0.8 - 1.2, 5.8 - 8.7)
Clearance	mm (in)	(C) 3 - 10 (0.3 - 1.0, 2.2 - 7.2)

C1 CLUTCH

3. Component Parts Removal and Installation, Assembly and Disassembly (Cont'd)

3-7 CLUTCH RELEASE MECHANISM REMOVAL AND INSTALLATION

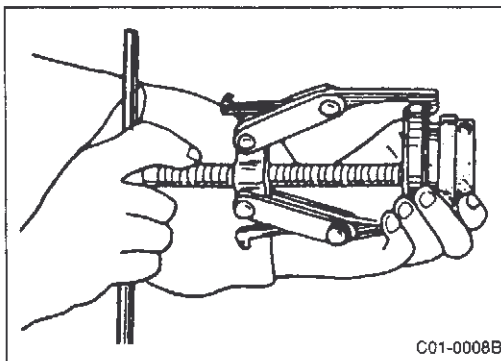
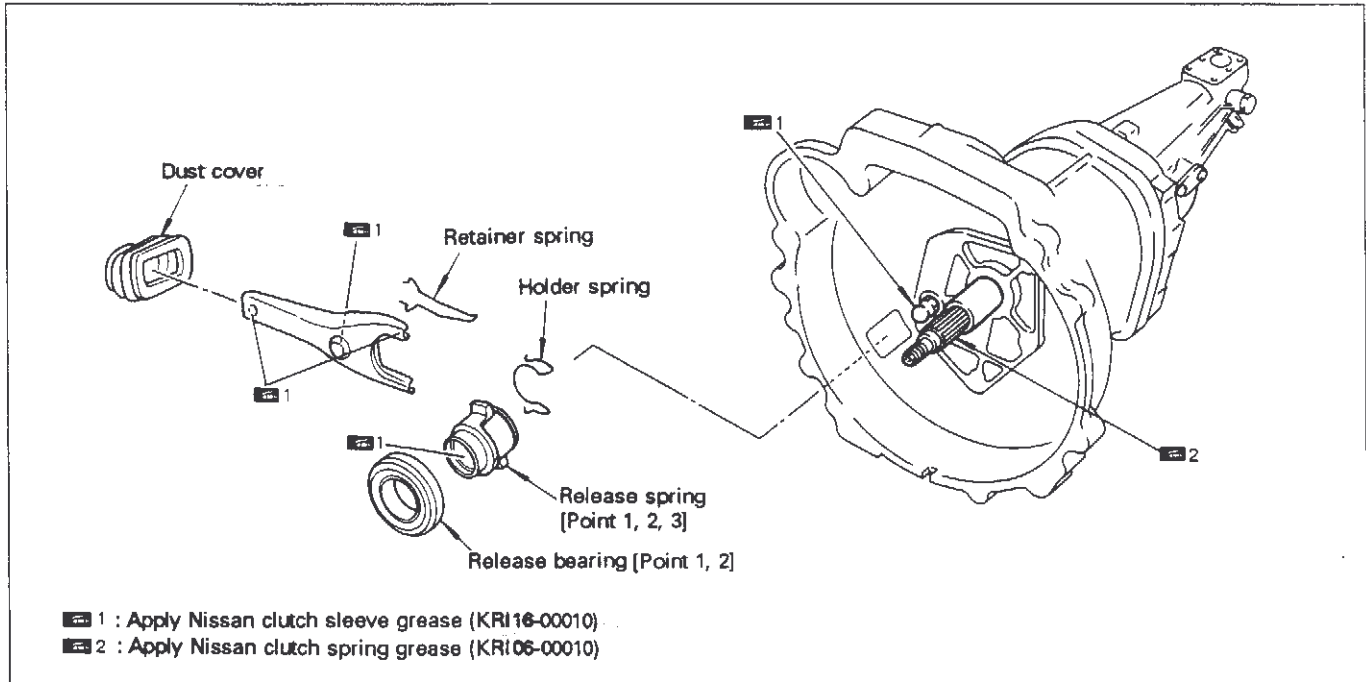

[Point 1] Release bearing removal and installation

Removal

- Use a puller as shown in figure on left to remove bearing. (Position a suitable drift on the sleeve.)

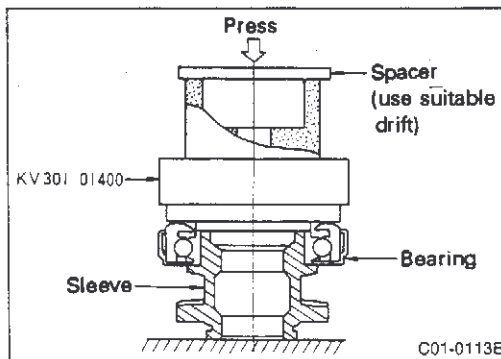

Installation

- Use the release bearing drift (special service tool) as shown in the figure to install the bearing.

CAUTION:

A drift must be used to press against the inner race.

C1 CLUTCH

3. Component Parts Removal and Installation, Assembly and Disassembly (Cont'd)

[Point 2] Inspection

Check the following items and replace if necessary.

- Release bearing, to see that it rolls freely and is free from noise, cracks, pitting or wear
- Release sleeve and withdrawal lever rubbing surface, for wear rust or damage.

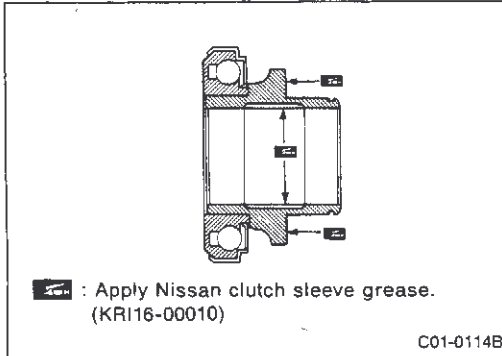

[Point 3] Lubrication

- Lubricate locations indicated by arrow with Nissan clutch sleeve grease (KRI16-00010).

3-8 CLUTCH COVER INSPECTION AND DISK, INSPECTION AND ADJUSTMENT

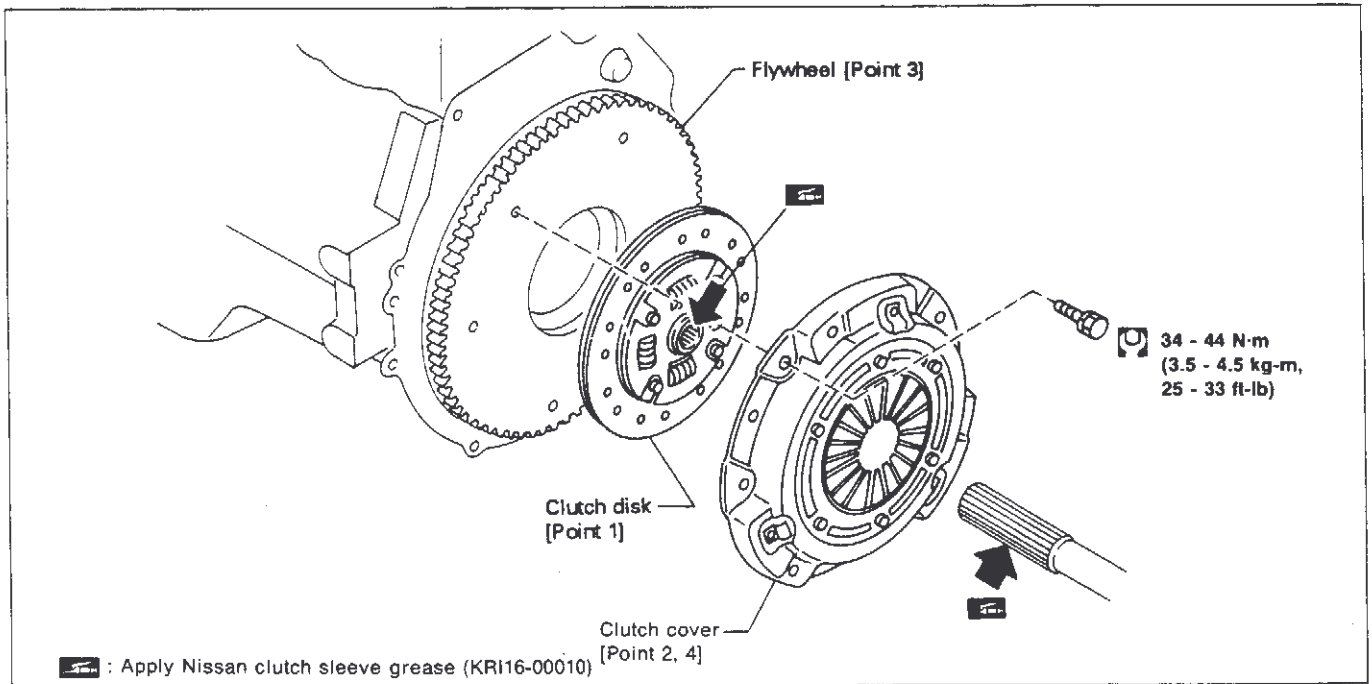

C1 CLUTCH

3. Component Parts Removal and Installation, Assembly and Disassembly (Cont'd)

[Point 1] Clutch disk inspection

- Use calipers to measure the depth of facing surface to the rivet head. If wear exceeds specification limit, replace clutch disc.

Facing wear limit (depth to rivet head)	mm (in)	0.3 (0.012) min.
--	---------	------------------

- If the surface runout or spline backlash (from hub center) exceeds specified limit, adjust or replace disk.

Description	Engine	RB26DETT
Facing runout/measurement part position	mm (in)	1.0 (0.039) max./230 (9.06) dia.

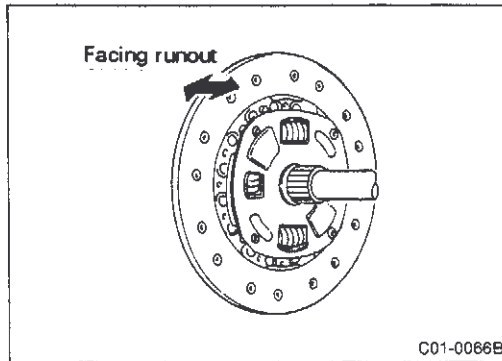
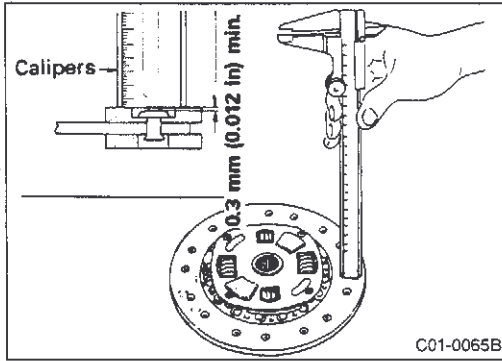

[Point 2] Clutch cover inspection

- Use the base plate (special service tool) and distance piece (special service tool) to measure the diaphragm spring lever height (dimension H). Replace the cover ASSY if it does not conform to the standard dimensions.

Lever set height (dimension H) standard:
37.5 - 39.5 mm (1.476 - 1.555 in)

Base plate	ST2005-0010
Distance piece	ST2005-0100

CAUTION:

In vehicles equipped with the RB26DETT engine, place 0.3 mm (0.012 in) thickness gauge in distance piece (ST2005 0010), place it on clutch cover and measure the distance.

Clutch cover tightening torque:

34 - 44 N·m (3.5 - 4.5 kg·m, 25 - 33 ft·lb)

- Adjust unevenness of diaphragm spring with diaphragm adjustment wrench (special service tool).

Diaphragm spring unevenness limit:
0.5 mm (0.020 in) max.

CAUTION:

The correction can only be performed if it is within allowable limit before the lever set height adjustment is performed.

- Check thrust ring for wear or damage. Replace if necessary.

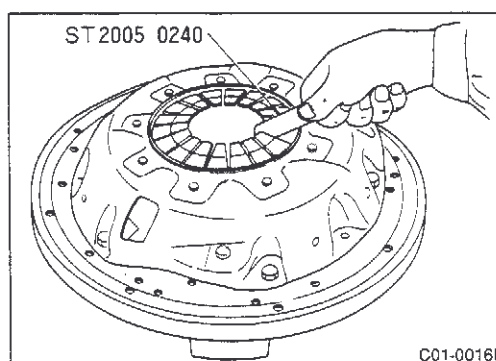
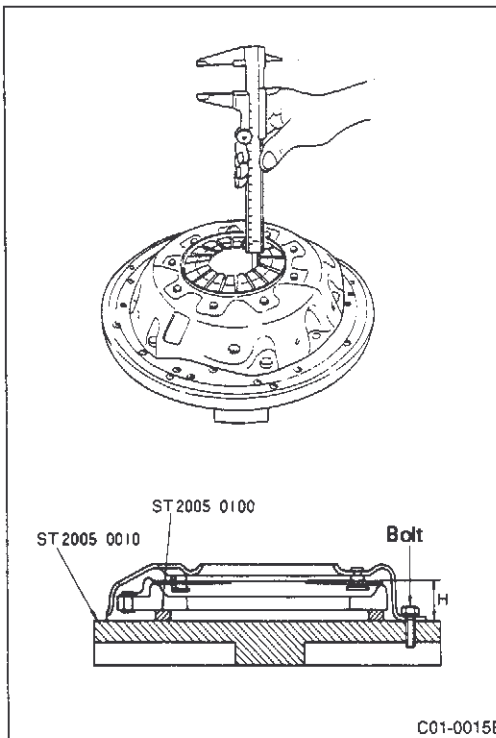

C1 CLUTCH

3. Component Parts Removal and Installation, Assembly and Disassembly (Cont'd)

Bend damage: A chattering sound is produced when cover is shaken vertically.

Wear: A slightly cracked sound is produced if rivets are struck lightly with hammer.

- Check pressure plate and clutch disc contact surface for slight burns or discoloration. Repair pressure plate with emery paper.
- Check pressure plate and clutch disc contact surface for deformation or damage. Replace if necessary.

[Point 3] Flywheel inspection

- Check contact surface of flywheel for slight burns or discoloration. Repair flywheel with emery paper.

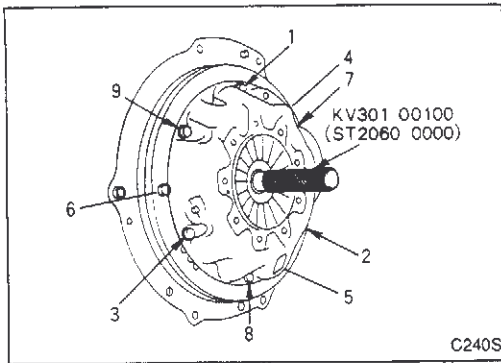

[Point 4] Clutch disk and cover installation

- Apply recommended grease (KRI06-00010) to contact surface of clutch disc spline.
- Too much lubricant may damage clutch disk facing and pressure plate surface.
- Use clutch disk alignment tool (special service tool) before tightening clutch cover bolts.
- Tighten bolts in sequence shown in figure.

C2 MANUAL TRANSMISSION

OPERATION PRECAUTIONS

- Only use genuine Nissan gear oil MP-G special GL-4 75W-90 for the transmission.
- Never reuse transmission oil.
- Make sure no dirt, debris or foreign matter enters the transmission during assembly or disassembly.
- Use a torque wrench to tighten bolts and nuts to specified torque.

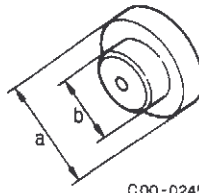
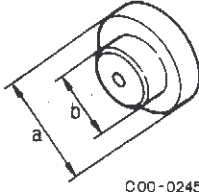

SPECIAL SERVICE TOOLS

Tool name Tool number	Description	
Pin punch KV321 01100 6 mm (0.24 in)	 C00-0084	Striking lever and striking arm assembly and disassembly
Drift ST3532 2000 Drift bar ST3532 5000	 C00-0245 a: 39 mm (1.54 in) dia. b: 31 mm (1.22 in) dia.	Mainshaft and rear end bearing removal
Drift ST3532 1000 Drift bar ST3532 5000	 C00-0245 a: 49 mm (1.93 in) dia. b: 41 mm (1.61 in) dia.	Mainshaft and rear end bearing removal

a: Outer diameter of drift
b: Inner diameter of drift

C2 MANUAL TRANSMISSION

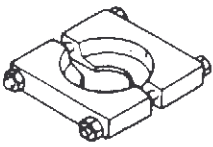
*: Special service tool or commercial equivalent

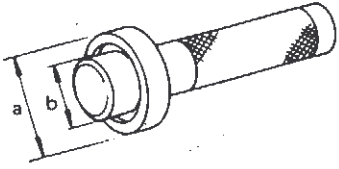
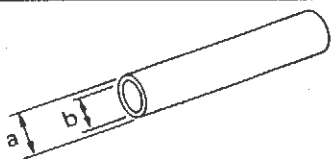
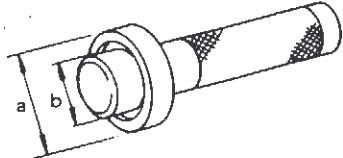
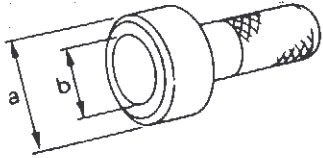
Tool number Tool name	Description
ST23540000* Pin punch	 <p>Removing and installing retaining pin</p>
ST30031000* Puller	 <p>Removing 1st & 2nd synchronizer assembly Removing counter gear rear thrust bearing Removing main drive bearing</p>
ST33290001* Puller	 <p>Removing rear oil seal</p>
ST33230000* Drift	 <p>Removing mainshaft and counter gear</p> <p>a: 51 mm (2.01 in) dia. b: 28.5 (1.122 in) dia.</p>
ST22350000* Drift	 <p>Removing counter gear front bearing (Use with KV38100300.)</p> <p>a: 34 mm (1.34 in) dia. b: 28 mm (1.10 in) dia.</p>
KV38100300* Drift	 <p>Removing counter gear front bearing (Use with ST22350000.) Installing counter gear rear bearing</p> <p>a: 54 mm (2.13 in) dia. b: 32 mm (1.26 in) dia.</p>
ST30720000* Drift	 <p>Removing mainshaft front bearing. Installing mainshaft front bearing.</p> <p>a: 77 mm (3.03 in) dia. b: 55.5 mm (2.185 in) dia.</p>

a: Outer diameter of drift
b: Inner diameter of drift

C2 MANUAL TRANSMISSION

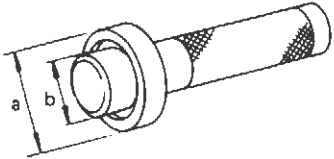
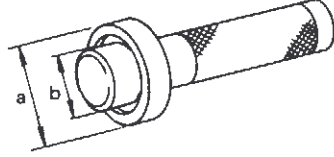
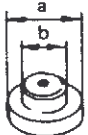
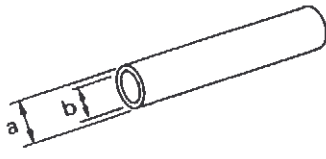
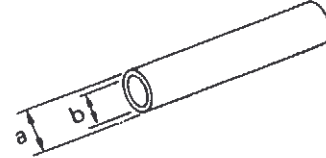
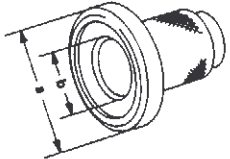
Tool number Tool name	Description
ST33210000* Drift	 <p>a: 44 mm (1.73 in) dia. b: 24.5 mm (0.965 in) dia.</p> <p>Installing counter gear front bearing Installing front cover oil seal</p>
ST3320000* Drift	 <p>a: 37mm (1.46 in) dia. b: 22 mm (0.87 in) dia.</p> <p>Removing and installing counter gear and rear end bearing</p>
ST30613000* Drift	 <p>a: 72 mm (2.83 in) dia. b: 48 mm (1.89 in) dia.</p> <p>Installing main drive gear bearing</p>
ST37750000* Drift	 <p>a: 40 mm (1.57 in) dia. b: 31 mm (1.22 in) dia.</p> <p>Removing counter gear rear bearing Installing O.D. gear bushing Installing reverse cone Installing reverse counter gear Installing counter gear rear end bearing</p>
ST22452000* Drift	 <p>a: 45 mm (1.77 in) dia. b: 36 mm (1.42 in) dia.</p> <p>Installing reverse hub Installing mainshaft rear bearing</p>
ST33400001* Drift	 <p>a: 60 mm (2.36 in) dia. b: 47 mm (1.85 in) dia.</p> <p>Installing rear oil seal</p>



a: Outer diameter of drift

b: Inner diameter of drift

* : Special service tool or commercial equivalent

C2 MANUAL TRANSMISSION

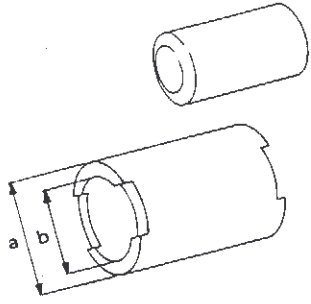
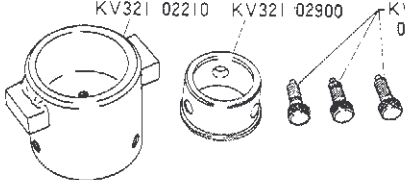
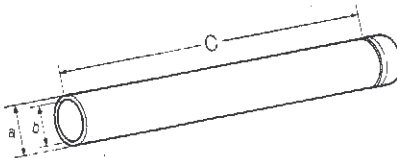
*: Special service tool or commercial equivalent

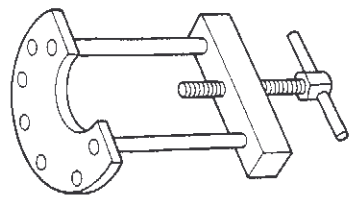
Tool number Tool name	Description
ST36730000* Drift	 <p>Installing sub-gear on reverse idler gear</p> <p>a: 50 mm (1.97 in) dia. b: 39 mm (1.54 in) dia.</p>
Spacer hook KV321 02210 Spacer KV321 02900 Bolt KV321 02230	 <p>Removing 5th gear bushing (Use with HT72350000.)</p>
Drift KV321 02700	 <p>Installing 5th gear Installing mainshaft rear bearing Installing reverse gear bushing Installing reverse hub</p> <p>a: 48.6 mm (1.913 in) dia. b: 41.6 mm (1.638 in) dia. c: 410 mm (16.14 in) dia.</p>
Drift KV321 02800	 <p>Installing sub-gear snap ring</p> <p>a: 41.0 mm (1.614 in) dia. b: 35.5 mm (1.398 in) dia.</p>
Bearing puller ST2247 0000	 <p>Removing reverse gear and reverse hub</p>

a: Outer diameter of drift
b: Inner diameter of drift

C2 MANUAL TRANSMISSION

COMMERCIAL SERVICE TOOLS

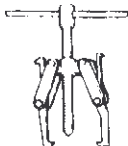
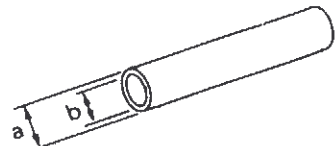
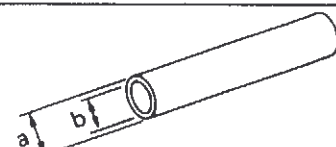
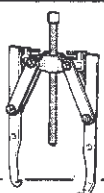
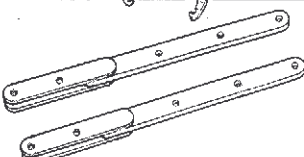
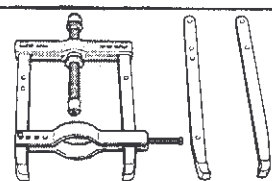
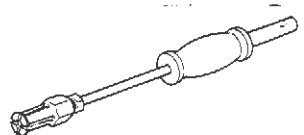
Tool name Tool number	Description
Transmission jack Engine sling tool	Engine support during transmission removal and installation
Puller HT235 0000	 <p>Removing counter gear rear end bearing Removing mainshaft rear bearing Removing reverse gear synchronizer hub Removing reverse counter gear</p>
Drift	 <p>Installing sub-gear snap ring</p> <p>a: 44.5 mm (1.752 in) dia. b: 38.5 mm (1.516 in) dia.</p>
Drift	 <p>Installing O.D. main gear Installing reverse gear bushing</p> <p>a: 44.5 mm (1.752 in) dia. b: 40.5 mm (1.594 in) dia.</p>
Puller HT723 4000	 <p>Removing reverse gear bushing (Use with HT726 1000.)</p>
Joint HT726 1000	 <p>Removing reverse gear bushing (Use with HT723 4000.)</p>
Puller HT726 0000	 <p>Removing 5th gear</p>
Blind bearing puller BL600	 <p>Removing striking rod side ball bearing</p>

a: Outer diameter of drift
b: Inner diameter of drift

C2 MANUAL TRANSMISSION

1. Summary

Specifications

Description		Engine	RB26DETT
Model			FS5R30A
Model No. (Note 1)			05U10
Gear ratio	1st gear		3.214
	2nd gear		1.925
	3rd gear		1.302
	4th gear		1.000
	5th gear		0.752
	Reverse gear		3.369
Number of gear teeth	Main drive gear		23
	Mainshaft	1st gear	31
		2nd gear	30
		3rd gear	29
		5th gear	24
		Reverse gear	30
	Counter	Drive gear	31
		1st gear	13
		2nd gear	21
		3rd gear	30
		5th gear	43
		Reverse gear	12
		Reverse idler gear	22
Transmission switch		Neutral	Attached
Total length		mm (in) (Note 2)	625 (24.61)
Recommended oil and quantity		ℓ (Imp qt)	Nissan gear oil MP-G special GL-4 #75-90 approx. 4.1 (3-5/8)

Note: 1. The model number is indicated in the last five digits of the part number (32010 XXXXX).

2. The total length indicates length from front edge of clutch case to rear edge of OD cover.

C2 MANUAL TRANSMISSION

1. Summary (Cont'd)

Inspection standard values

Unit: mm (in)

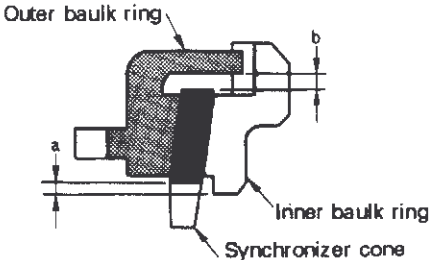
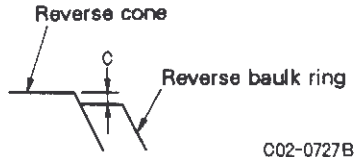
Description	Standard value												
End play 1st gear 2nd gear 3rd gear 5th gear	0.23 - 0.33 (0.0091 - 0.0130)												
Reverse gear	0.11 (0.0043) max.												
Reverse idler gear	0.33 - 0.43 (0.0130 - 0.0169)												
Counter gear	0.10 - 0.25 (0.0039 - 0.0098)												
Baulk ring clearance 1st, 4th, 5th gear 2nd, 3rd gear	<p style="text-align: center;">1.05 - 1.30 (0.0413 - 0.0512) [Usage limit value: 0.7 (0.028) max.] Clearance a: 0.6 - 1.10 (0.0236 - 0.0433) Clearance b: 0.70 - 0.90 (0.0276 - 0.0354) [Usage limit value: 0.2 (0.008) max.]</p> <div style="text-align: center;">  <p style="text-align: right;">C02-0726B</p> </div>												
Reverse cone — baulk ring clearance height	<p style="text-align: center;">Clearance C: -0.10 to 0.35 (-0.0039 to 0.0138) [Usage limit value: 0.7 (0.028)]</p> <div style="text-align: center;">  <p style="text-align: right;">C02-0727B</p> </div>												
Main drive gear snap ring	<p style="text-align: center;">End play standard value: 0.1 (0.004) max.</p> <table border="1" style="width: 100%; border-collapse: collapse;"> <thead> <tr> <th style="width: 50%;">Thickness</th> <th style="width: 50%;">Part number</th> </tr> </thead> <tbody> <tr> <td style="text-align: center;">1.89 (0.0744)</td> <td style="text-align: center;">32204 01G00</td> </tr> <tr> <td style="text-align: center;">1.98 (0.0780)</td> <td style="text-align: center;">32204 01G01</td> </tr> <tr> <td style="text-align: center;">2.05 (0.0807)</td> <td style="text-align: center;">32204 01G02</td> </tr> <tr> <td style="text-align: center;">2.12 (0.0835)</td> <td style="text-align: center;">32204 01G03</td> </tr> <tr> <td style="text-align: center;">2.19 (0.0862)</td> <td style="text-align: center;">32204 01G04</td> </tr> </tbody> </table>	Thickness	Part number	1.89 (0.0744)	32204 01G00	1.98 (0.0780)	32204 01G01	2.05 (0.0807)	32204 01G02	2.12 (0.0835)	32204 01G03	2.19 (0.0862)	32204 01G04
Thickness	Part number												
1.89 (0.0744)	32204 01G00												
1.98 (0.0780)	32204 01G01												
2.05 (0.0807)	32204 01G02												
2.12 (0.0835)	32204 01G03												
2.19 (0.0862)	32204 01G04												
Mainshaft (front) snap ring	<p style="text-align: center;">End play standard value: 0.1 (0.004) max.</p> <table border="1" style="width: 100%; border-collapse: collapse;"> <thead> <tr> <th style="width: 50%;">Thickness</th> <th style="width: 50%;">Part number</th> </tr> </thead> <tbody> <tr> <td style="text-align: center;">1.89 (0.0744)</td> <td style="text-align: center;">32204 01G00</td> </tr> <tr> <td style="text-align: center;">1.98 (0.0780)</td> <td style="text-align: center;">32204 01G01</td> </tr> <tr> <td style="text-align: center;">2.05 (0.0807)</td> <td style="text-align: center;">32204 01G02</td> </tr> <tr> <td style="text-align: center;">2.12 (0.0835)</td> <td style="text-align: center;">32204 01G03</td> </tr> <tr> <td style="text-align: center;">2.19 (0.0862)</td> <td style="text-align: center;">32204 01G04</td> </tr> </tbody> </table>	Thickness	Part number	1.89 (0.0744)	32204 01G00	1.98 (0.0780)	32204 01G01	2.05 (0.0807)	32204 01G02	2.12 (0.0835)	32204 01G03	2.19 (0.0862)	32204 01G04
Thickness	Part number												
1.89 (0.0744)	32204 01G00												
1.98 (0.0780)	32204 01G01												
2.05 (0.0807)	32204 01G02												
2.12 (0.0835)	32204 01G03												
2.19 (0.0862)	32204 01G04												

C2 MANUAL TRANSMISSION

1. Summary (Cont'd)

Unit: mm (in)

Description	Standard value	
Mainshaft C ring (rear)	End play standard value: 0.1 (0.004) max.	
	Thickness	Part number
	2.63 (0.1035)	32348 01G15
	2.70 (0.1063)	32348 01G00
	2.77 (0.1091)	32348 01G01
	2.84 (0.1118)	32348 01G02
	2.91 (0.1146)	32348 01G03
	2.98 (0.1173)	32348 01G04
	3.05 (0.1201)	32348 01G05
	3.12 (0.1228)	32348 01G06
	3.19 (0.1256)	32348 01G07
	3.26 (0.1283)	32348 01G08
	3.33 (0.1311)	32348 01G09
	3.40 (0.1339)	32348 01G10
	3.47 (0.1366)	32348 01G11
3.54 (0.1394)	32348 01G12	
3.61 (0.1421)	32348 01G13	
3.68 (0.1449)	32348 01G14	
Counter gear front thrust washer	End play standard value: 0.1 (0.004) max.	
	Thickness	Part number
	0.8 (0.031)	32218 01G00
	0.9 (0.035)	32218 01G01
	1.0 (0.039)	32218 01G02
	1.1 (0.043)	32218 01G03
	1.2 (0.047)	32218 01G04
	1.3 (0.051)	32218 01G05
1.4 (0.055)	32218 01G06	
Counter gear rear snap ring	End play standard value: 0.1 (0.004) max.	
	Thickness	Part number
	1.26 (0.0496)	32236 01G08
	1.32 (0.0520)	32236 01G00
	1.38 (0.0543)	32236 01G01
	1.44 (0.0567)	32236 01G02
	1.50 (0.0591)	32236 01G03
	1.56 (0.0614)	32236 01G04
	1.62 (0.0638)	32236 01G05
	1.68 (0.0661)	32236 01G06
1.74 (0.0685)	32236 01G07	
Reverse idler thrust washer	End play standard value: 0.1 (0.004) max.	
	Thickness	Part number
	1.97 (0.0776)	32284 01G10
2.07 (0.0815)	32284 01G11	

C2 MANUAL TRANSMISSION

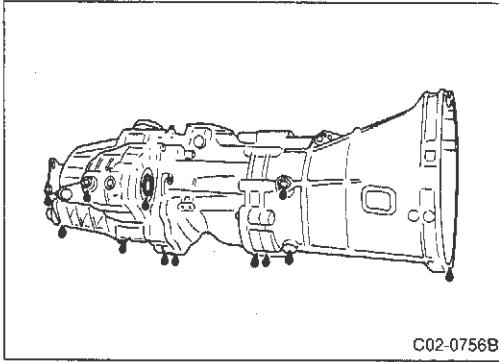

2. On-Vehicle Inspection and Adjustment

2-1 OIL LEAK INSPECTION

- If there are oil leaks from any transmission part, remove transmission ASSY from vehicle and change oil.

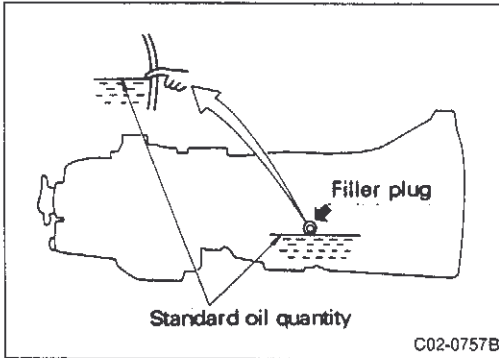

2-2 OIL QUANTITY INSPECTION

- Check oil quantity through filler plug hole.
- Use only genuine Nissan gear oil MP-G special GL-4 75W-90.

3. Transmission Removal and Installation, Assembly and Disassembly

3-1 REMOVAL AND INSTALLATION

Additional work required:

Use jack to support transmission during removal and installation.

Drain and refill:

Transmission oil
Transfer oil

Remove and install:

Speedometer cable
Propeller shaft
Clutch operating cylinder
Starter motor ASSY
Control lever [Point 1]
Reverse lamp switch and neutral switch wiring
Exhaust pipe [Point 2]
E-TS hydraulic unit air bleeder [Point 4]

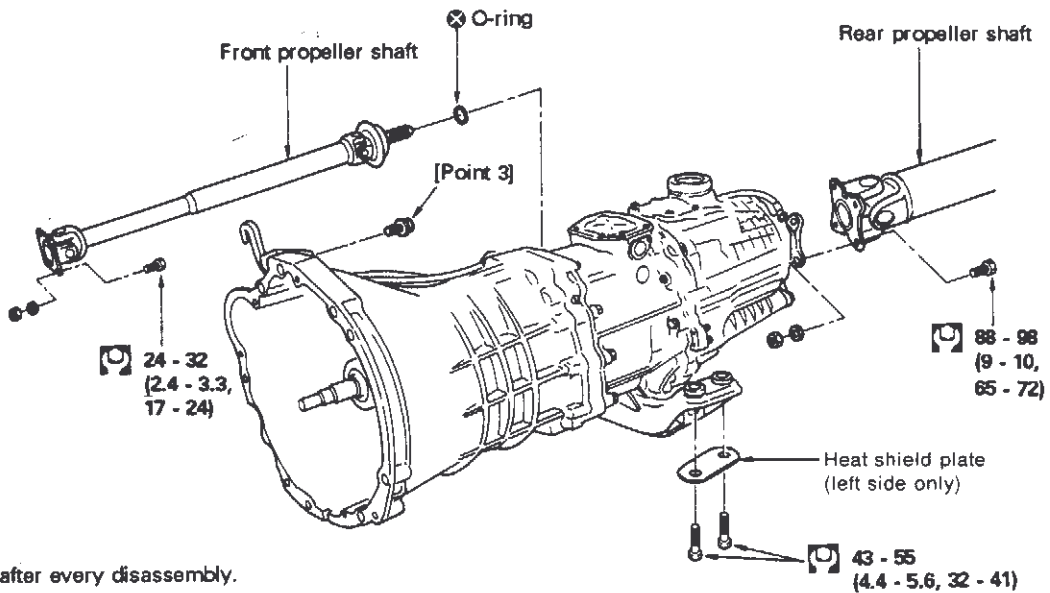

C2 MANUAL TRANSMISSION

3. Transmission Removal and Installation, Assembly and Disassembly (Cont'd)

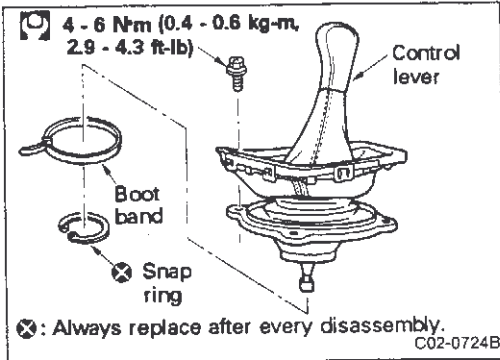

[Point 1] Control lever removal

- Remove control lever finisher and control lever dust boot.
- Remove snap ring from transmission control cover. Next, remove control lever.

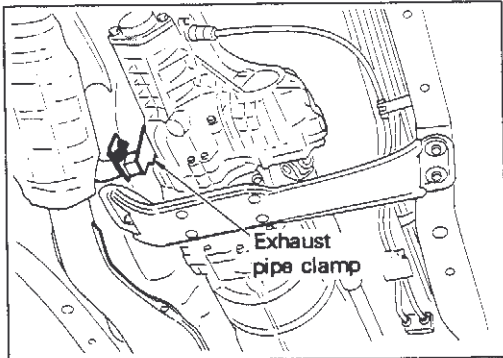

[Point 2] Exhaust pipe clamp removal

- Remove exhaust pipe clamp.
- Consider operability in front end of transmission and detach exhaust manifold and front exhaust pipe.

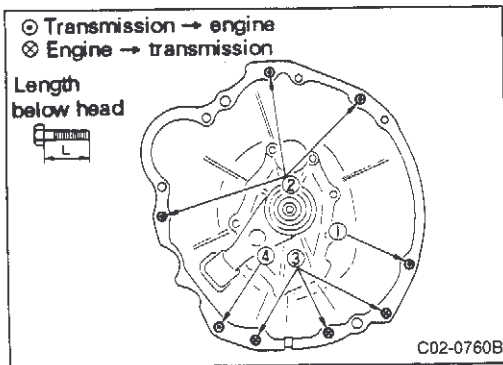

[Point 3] Transmission bolts

Vehicles equipped with RB26DETT engine

Bolt No.	Description	Tightening torque N·m (kg-m, ft-lb)	Bolt length below head mm (in)
①		39 - 49 (4.0 - 5.0, 29 - 36)	60 (2.36)
②		39 - 49 (4.0 - 5.0, 29 - 36)	60 (2.36)
③		29 - 39 (3.0 - 4.0, 22 - 29)	40 (1.57)
④ *		29 - 39 (3.0 - 4.0, 22 - 29)	50 (1.97)

The * symbol indicates bolts tightened by nuts.

Note: The figure on left shows transmission when viewed from engine side.

[Point 4] ETS hydraulic system air bleeding

- Refer to "C3, 4, 4-4 HYDRAULIC UNIT AND RESERVOIR TANK, [Point 3]" for air bleeding procedures.

C2 MANUAL TRANSMISSION

3. Transmission Removal and Installation, Assembly and Disassembly (Cont'd)

Case and shift control components

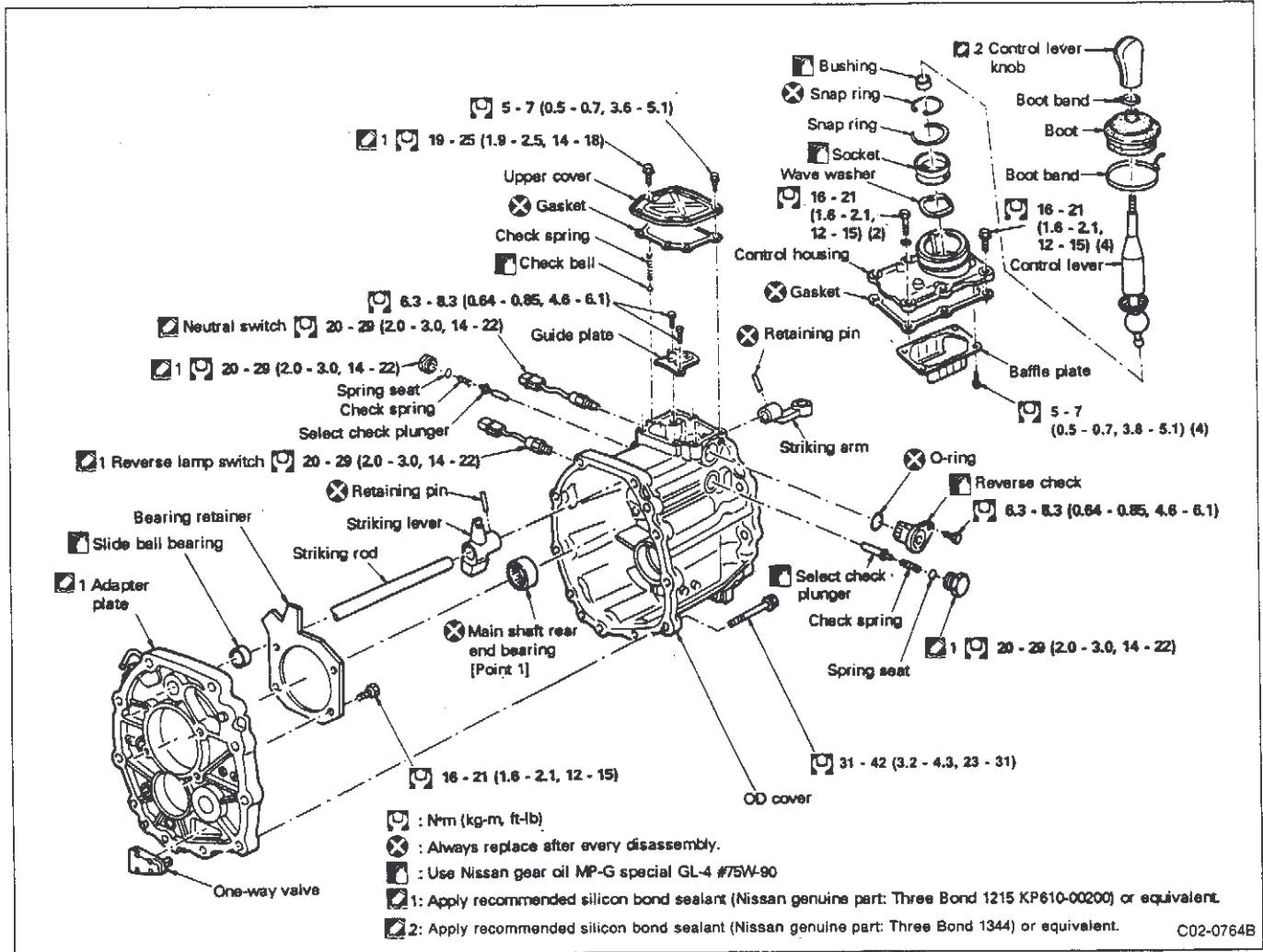

C2 MANUAL TRANSMISSION

3. Transmission Removal and Installation, Assembly and Disassembly (Cont'd)

Shift control components

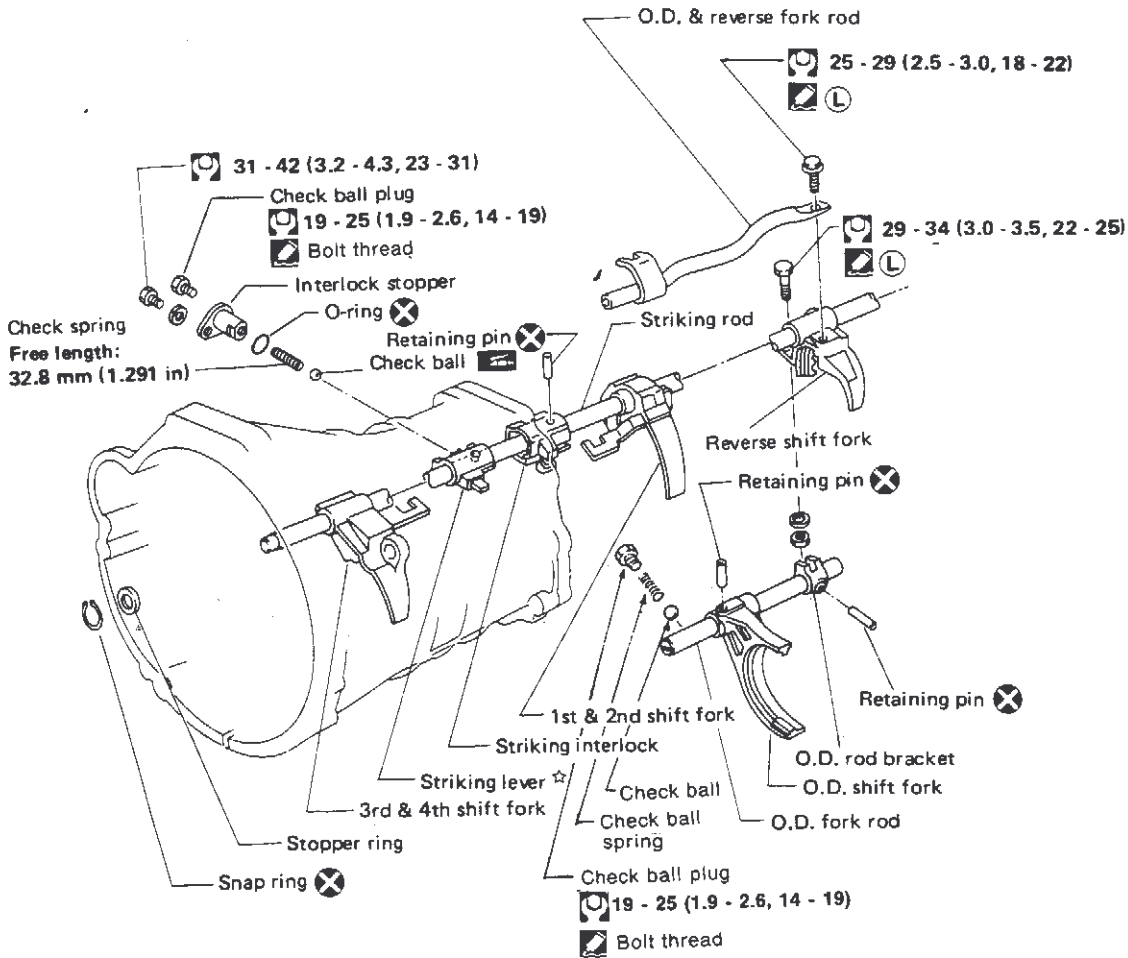

- ⊙ : N·m (kg·m, ft·lb)
- ◻ : Apply recommended sealant (Nissan genuine part: KP610-00250) or equivalent.
- ⊙ L : Apply locking sealant.
- ☆ : Pay attention to its direction.

C2 MANUAL TRANSMISSION

3. Transmission Removal and Installation, Assembly and Disassembly (Cont'd)

Gear components

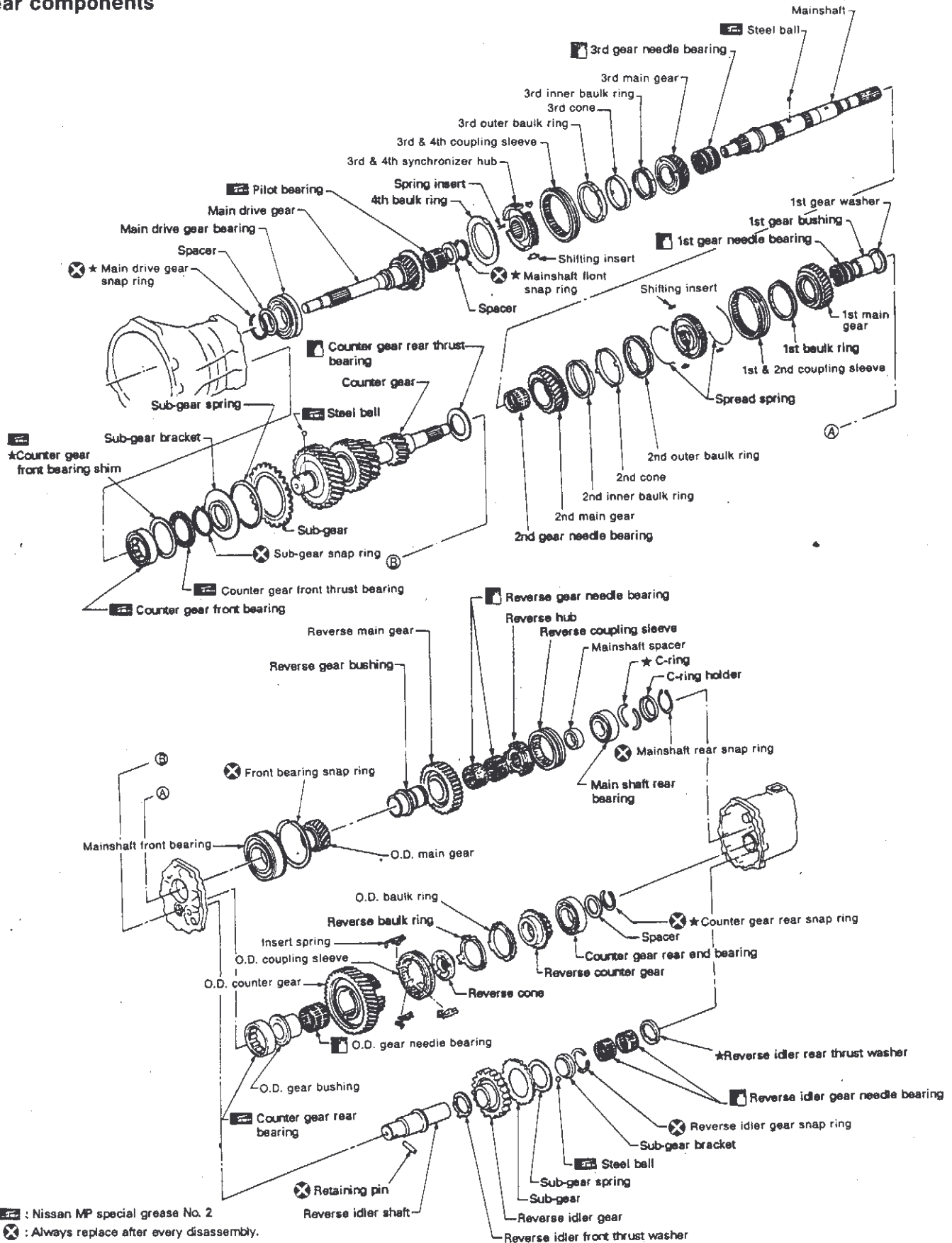

- : Nissan MP special grease No. 2
- : Always replace after every disassembly.
- : Selection part
- : Use Nissan gear oil MP-G special GL-4 75W-90

C2 MANUAL TRANSMISSION

3. Transmission Removal and Installation, Assembly and Disassembly (Cont'd)

2nd and 3rd gear double cone synchronizer components

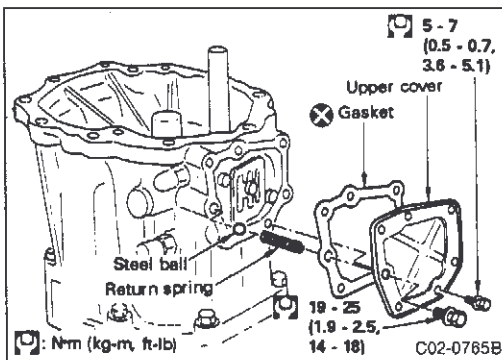
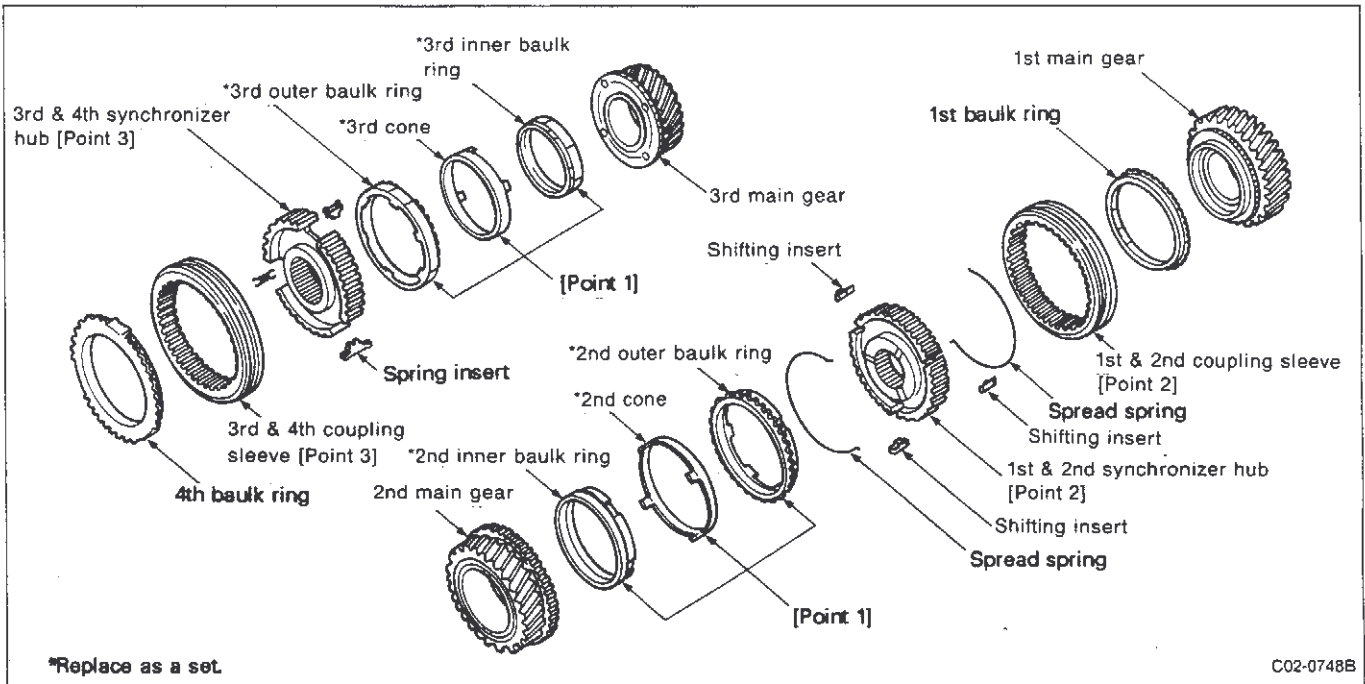

REAR EXTENSION DISASSEMBLY

- Remove upper cover and gasket. Remove return spring and check ball from rear extension.
- Remove reverse check, select check plunger and spring.
- Remove neutral switch and reverse lamp switch.

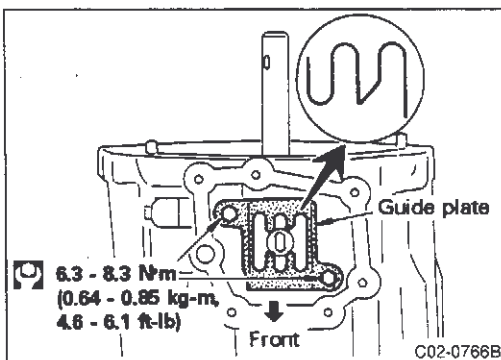

- Remove bolts and detach guide plate.

C2 MANUAL TRANSMISSION

3. Transmission Removal and Installation, Assembly and Disassembly (Cont'd)

- Use a pin punch (special service tool) to strike the striking lever retaining pin and remove pin.

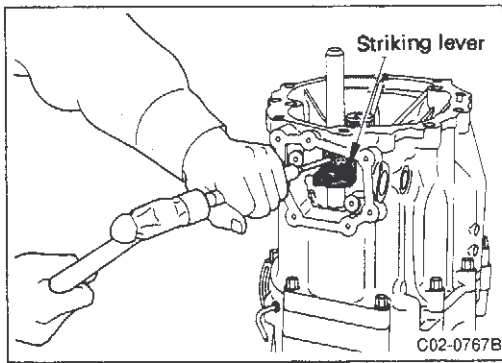

- Remove OD cover bolts. Tap cover with rubber hammer to separate it.

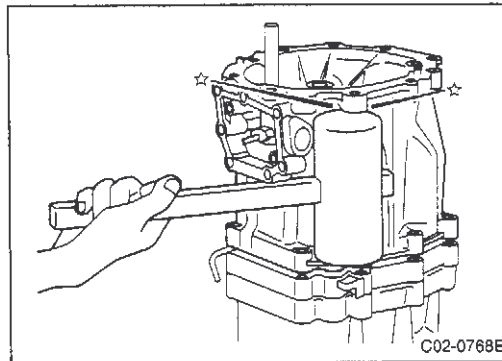

- Remove OD cover and striking lever as a set.

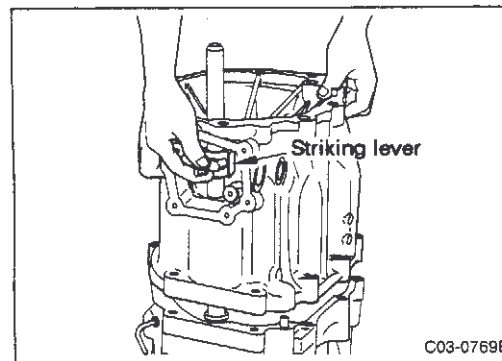

- Use drift (special service tool) to remove mainshaft rear end bearing.

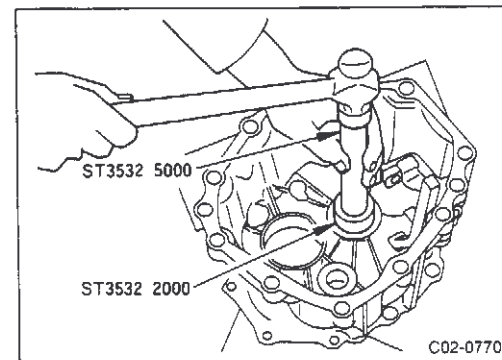

CASE COMPONENTS DISASSEMBLY

1. Remove check ball plug, check spring and check ball. Then remove interlock stopper.

If interlock assembly is removed as a unit, the check ball can fall into transmission case.

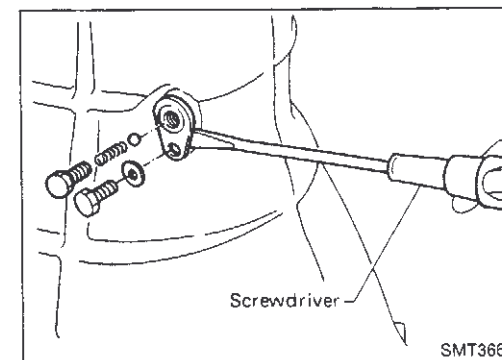

C2 MANUAL TRANSMISSION

3. Transmission Removal and Installation, Assembly and Disassembly (Cont'd)

2. Remove front cover and gasket.

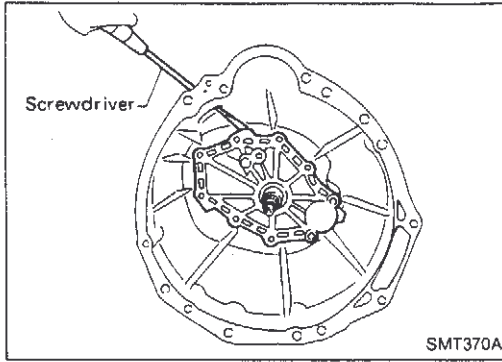

3. Remove stopper ring and main drive bearing snap ring.

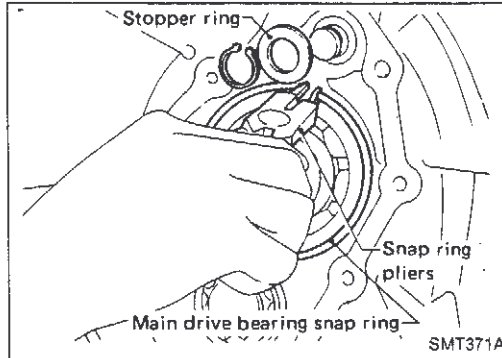

4. Remove transmission case by tapping lightly.

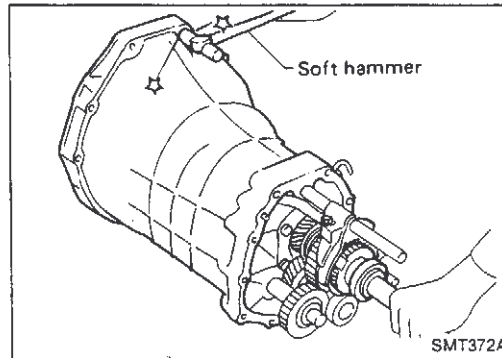

5. Remove front cover oil seal.

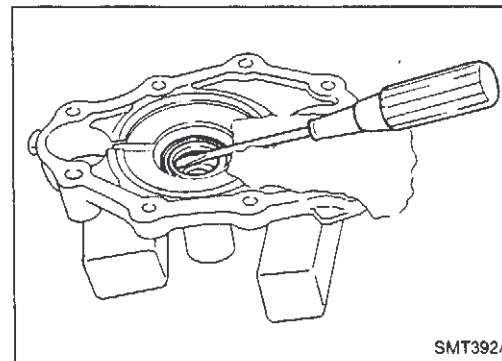

6. Remove slide ball bearing.

- Use screwdriver to remove the ball of the slide ball bearing and inner race.
- Set blind bearing puller on inset part of thrust ball bearing outer race as shown in the figure and remove race.
- Remove the adapter plate and rear extension slide ball bearing the same way.

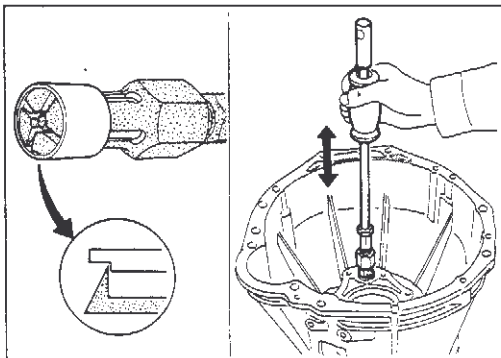

C2 MANUAL TRANSMISSION

3. Transmission Removal and Installation, Assembly and Disassembly (Cont'd)

SHIFT CONTROL COMPONENTS DISASSEMBLY

1. Mount adapter plate on vise.
2. Remove O.D. & reverse fork rod.

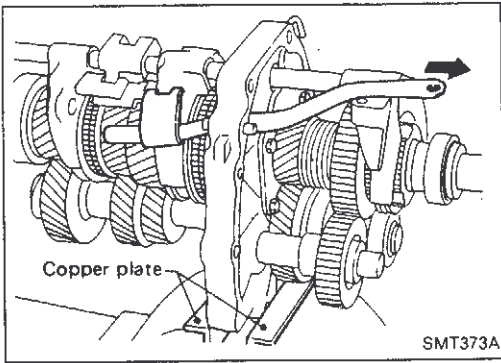

3. Remove check ball plug, check ball and return spring.

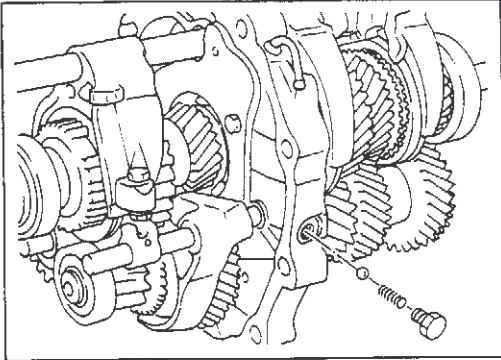

4. Drive out retaining pin from striking lever.
5. While pulling out striking rod, remove striking lever and striking interlock. Then remove 1st & 2nd, 3rd & 4th and reverse shift fork.

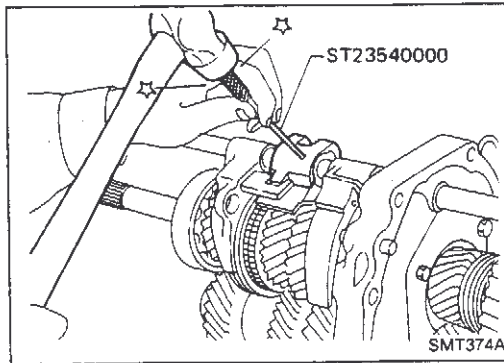

6. Drive out retaining pin from O.D. shift fork.
7. Pull out O.D. fork rod and then remove O.D. shift fork.

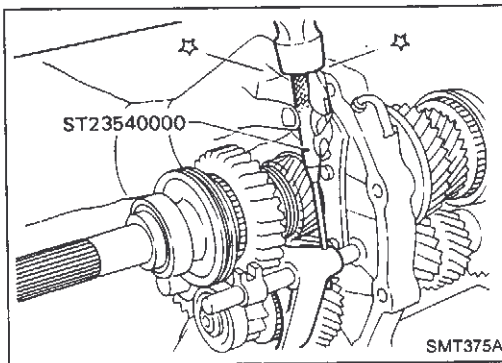

C2 MANUAL TRANSMISSION

3. Transmission Removal and Installation, Assembly and Disassembly (Cont'd)

GEAR COMPONENTS DISASSEMBLY

1. Before removing gears and shafts, measure each gear end play.

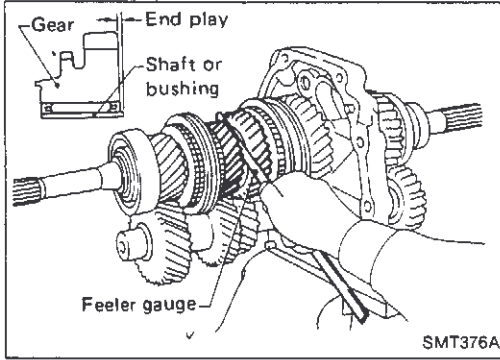

Gear	End play mm (in)
1st main gear	0.23 - 0.33 (0.0091 - 0.0130)
2nd main gear	0.23 - 0.33 (0.0091 - 0.0130)
3rd main gear	0.23 - 0.33 (0.0091 - 0.0130)
O.D. counter gear	0.23 - 0.33 (0.0091 - 0.0130)
Reverse main gear	0.33 - 0.43 (0.0130 - 0.0169)

- If not within specification, disassemble and check contact surface of gear to hub, washer, bushing, needle bearing and shaft.

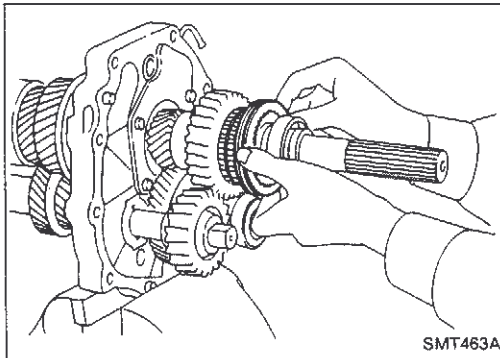

2. Remove rear side components on mainshaft and counter gear.
 - a. Remove reverse coupling sleeve.

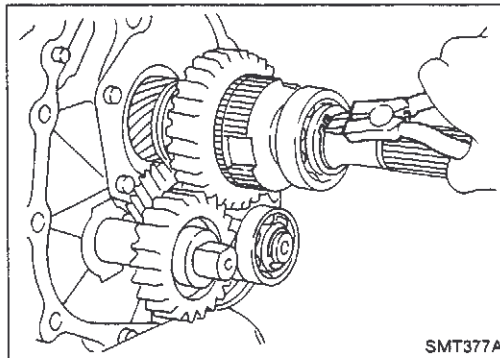

- b. Remove mainshaft rear snap ring and counter gear rear snap ring.
- c. Remove C-ring holder and mainshaft C-rings from mainshaft. Use punch and hammer to remove C-rings.

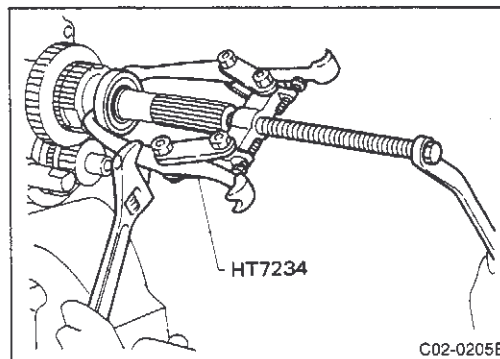

- d. Use puller to remove mainshaft rear bearing.

C2 MANUAL TRANSMISSION

3. Transmission Removal and Installation, Assembly and Disassembly (Cont'd)

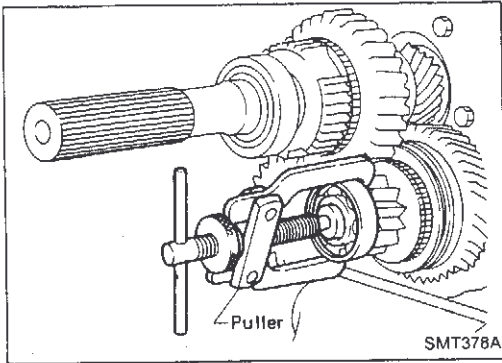

- e. Pull out counter gear rear end bearing.
- f. Remove reverse idler gear and reverse idler thrust washers.

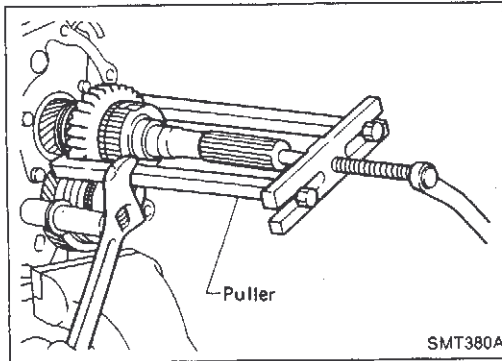

- g. Pull out reverse main gear together with mainshaft spacer and reverse synchronizer hub. Then remove reverse gear needle bearings.

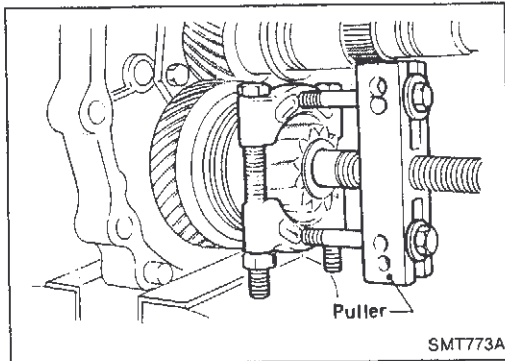

- h. Pull out reverse counter gear.
- i. Remove O.D. coupling sleeve together with O.D. baulk ring, reverse baulk ring and spring inserts.

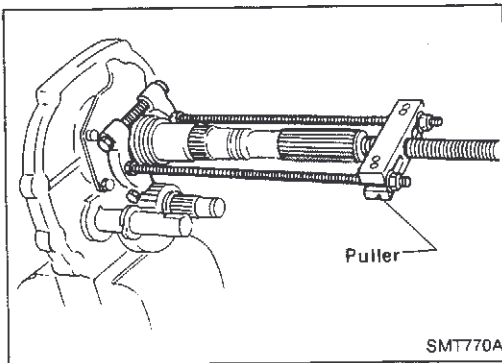

- j. Pull out reverse gear bushing.

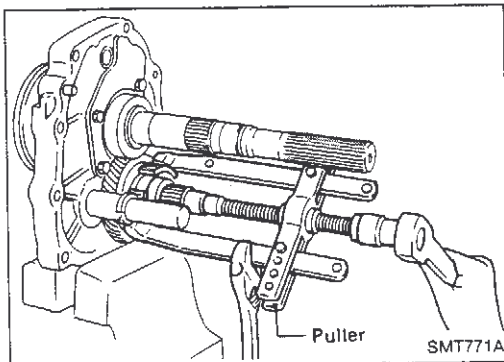

- k. Pull out O.D. counter gear together with reverse cone.

C2 MANUAL TRANSMISSION

3. Transmission Removal and Installation, Assembly and Disassembly (Cont'd)

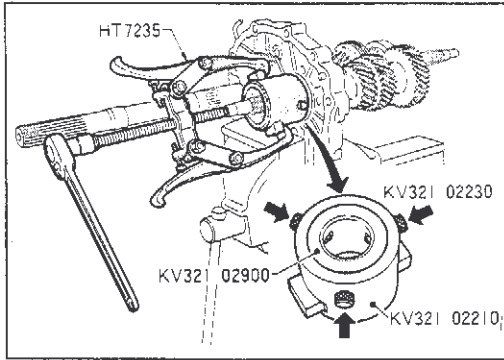

3. Remove 5th gear bushing, mainshaft ASSY, main drive gear ASSY and counter gear.
Set the bushing hook (special service tool) in the 5th gear bushing and use gear puller to remove 5th gear bushing.

CAUTION:

Position the bushing hook (special service tool) with 3 spacers.

4. Press out mainshaft and counter gear alternately.

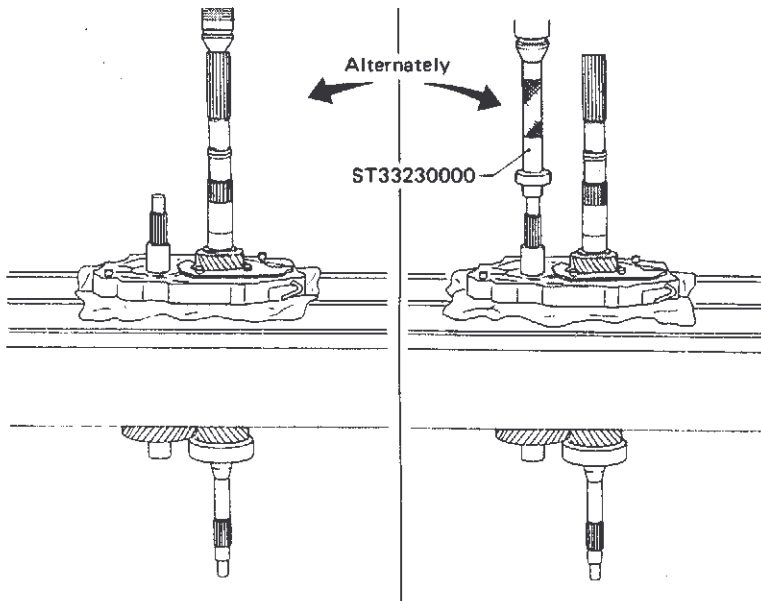

Make sure to alternate press between mainshaft and counter gear not to allow the front surface of one to contact the rear surface of the other.

SMT772A

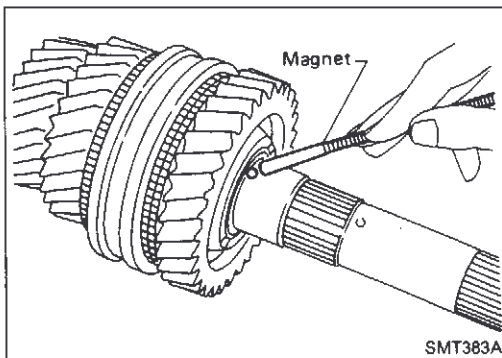

SMT383A

5. Remove front side components on mainshaft.
 - a. Remove 1st gear washer and steel ball.
 - b. Remove 1st main gear and 1st gear needle bearing.

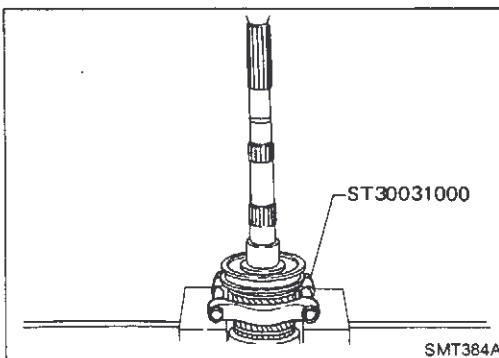

SMT384A

- c. Press out 2nd main gear together with 1st gear bushing and 1st & 2nd synchronizer assembly.
 - d. Remove mainshaft front snap ring.

C2 MANUAL TRANSMISSION

3. Transmission Removal and Installation, Assembly and Disassembly (Cont'd)

- e. Press out 3rd main gear together with 3rd & 4th synchronizer assembly and 3rd gear needle bearing.

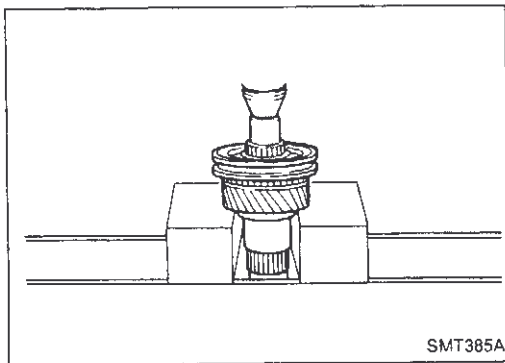

6. Remove front side components on counter gear.
a. Remove counter gear rear thrust bearing.

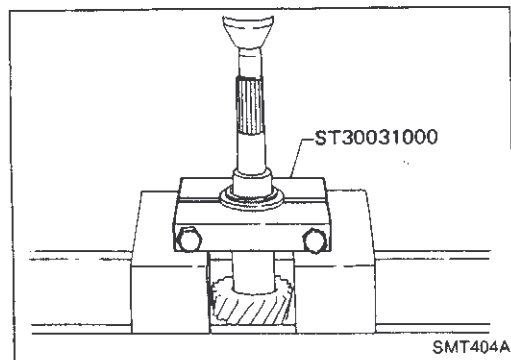

- b. Remove sub-gear components.

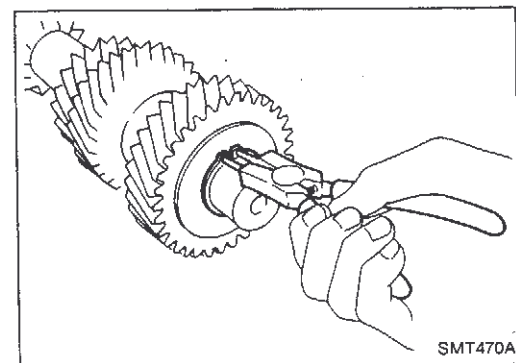

- c. Reverse idler sub-gear disassembly
Remove snap ring and detach sub-gear from reverse idler gear.

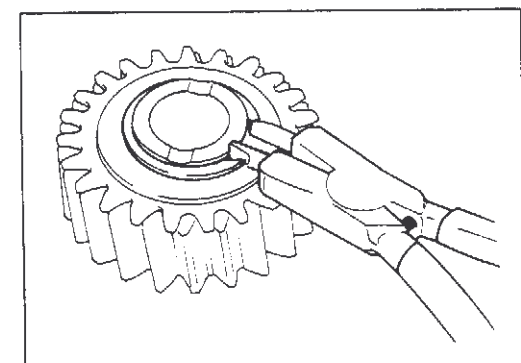

7. Remove main driver gear bearing.
a. Remove main drive gear snap ring and spacer.
b. Press out main drive gear bearing.

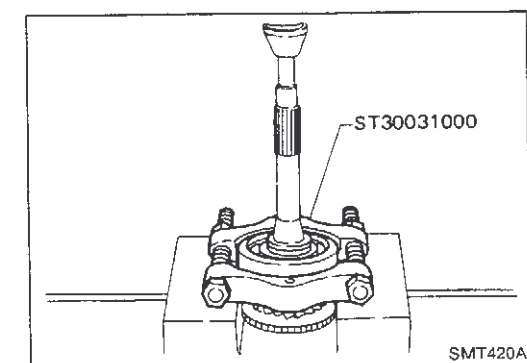

C2 MANUAL TRANSMISSION

3. Transmission Removal and Installation, Assembly and Disassembly (Cont'd)

8. Remove bearings from case components.

Counter gear front bearing in transmission case

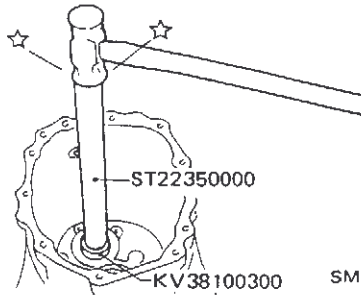

SMT388A

Mainshaft front bearing in adapter plate

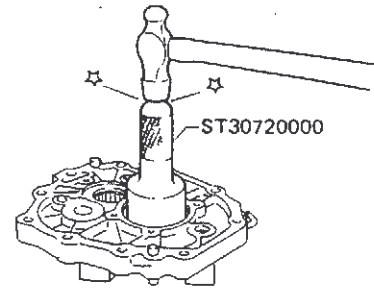

SMT396A

Counter gear rear end bearing in O.D. gear case

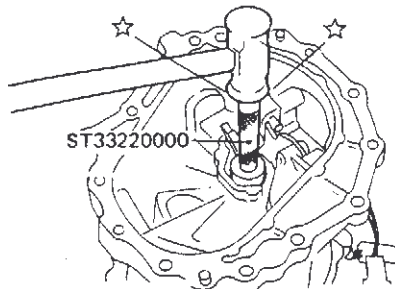

SMT390A

Counter gear rear bearing in adapter plate

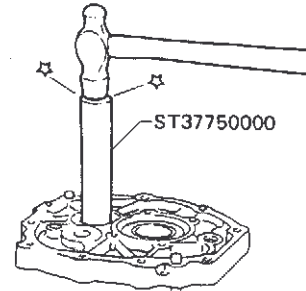

SMT394A

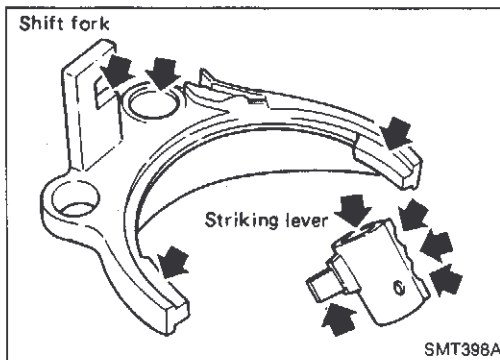

SHIFT CONTROL COMPONENTS INSPECTION

- Check contact surface and sliding surface for wear, scratches, projections or other damage.

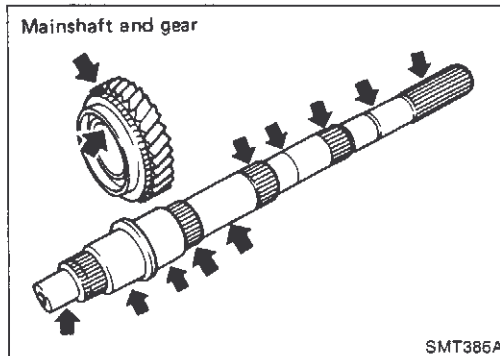

GEAR COMPONENTS INSPECTION

Gears and shafts

- Check shafts for cracks, wear or bending.
- Check gears for excessive wear, chips or cracks.

C2 MANUAL TRANSMISSION

3. Transmission Removal and Installation, Assembly and Disassembly (Cont'd)

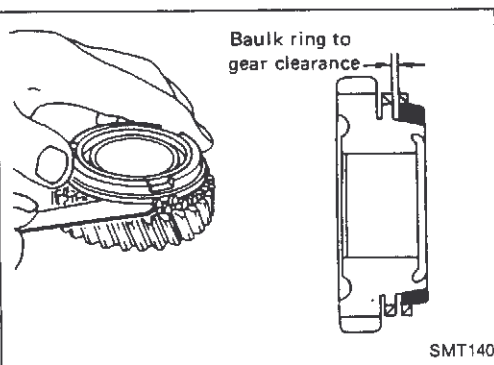
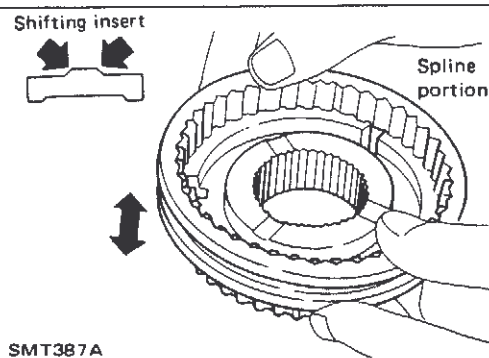
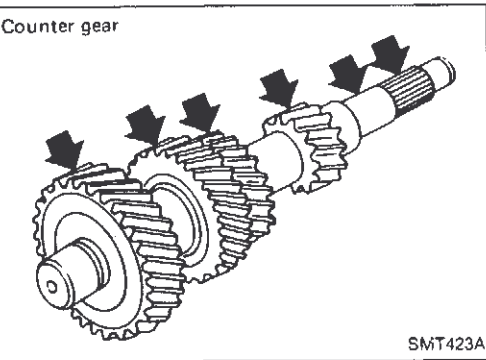

Synchronizers

- Check spline portion of coupling sleeves, hubs and gears for wear or cracks.
- Check baulk rings for cracks or deformation.
- Check shift inserts for wear or deformation.
- Check insert springs for deformation.

Clearance between baulk ring and gear

a. 1st, main drive & O.D. gear

Unit: mm (in)

	Standard	Wear limit
1st	1.05 - 1.3 (0.0413 - 0.0512)	0.7 (0.028)
Main drive	1.05 - 1.3 (0.0413 - 0.0512)	0.7 (0.028)
O.D.	1.05 - 1.3 (0.0413 - 0.0512)	0.7 (0.028)

If the clearance is smaller than the wear limit, replace baulk ring.

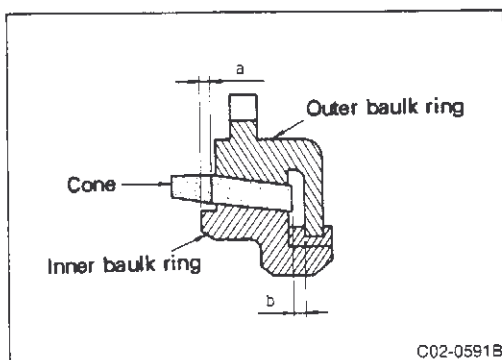

b. 2nd and 3rd gear

- The outer baulk ring, cone and inner baulk ring are a set and must maintain dimensions described below. If replacement is necessary, replace all three parts as an entire new set and then assemble.
- Clearance measurement.
- Measure clearance "a" and "b".

C2 MANUAL TRANSMISSION

3. Transmission Removal and Installation, Assembly and Disassembly (Cont'd)

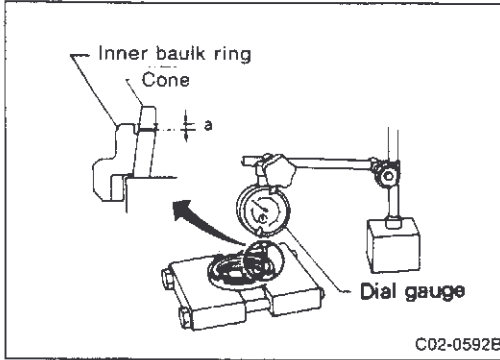

- Use a dial gauge to measure clearance dimension "a".
- Measure the part in two opposite locations and calculate average value.

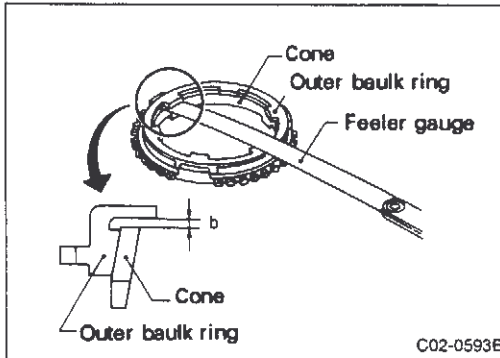

- Use feeler gauge to measure clearance "b".
- Measure the part in two adjacent locations and determine the average value.

Unit: mm (in)

Part	New value	Wear limit
Clearance a	0.65 - 1.1 (0.0256 - 0.0433)	0.2 (0.008) max.
Clearance b	0.7 - 0.9 (0.028 - 0.035)	0.2 (0.008) max.

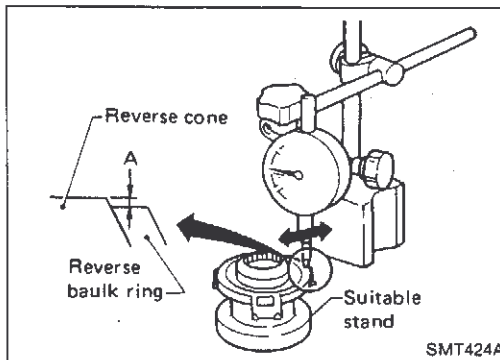

- Measure wear of reverse baulk ring. (1st, main drive and O.D. gear)
 - a. Place baulk ring in position on reverse cone.
 - b. While holding baulk ring against reverse cone as far as it will go, measure dimension "A" with dial indicator.

Unit: mm (in)

	Standard	Wear limit
Dimension "A"	-0.1 to 0.35 (-0.0039 to 0.0138)	0.7 (0.028)

- c. If dimension "A" is larger than the wear limit, replace baulk ring.

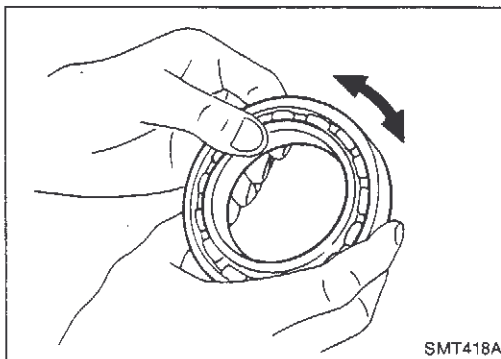

Bearings

- Make sure bearings roll freely and are free from noise, cracks, pitting or wear.

C2 MANUAL TRANSMISSION

3. Transmission Removal and Installation, Assembly and Disassembly (Cont'd) GEAR COMPONENTS ASSEMBLY

1. Install bearings into case components.

Counter gear front bearing in transmission case

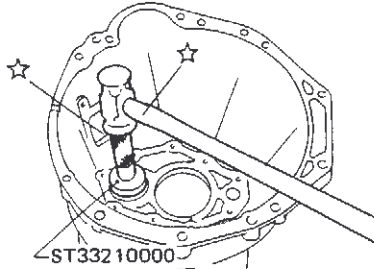

SMT389A

Mainshaft front bearing in adapter plate

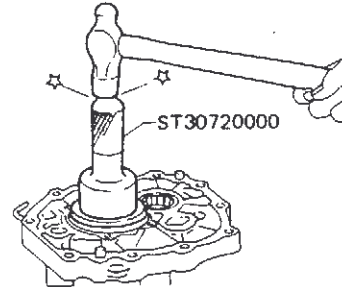

SMT397A

Counter gear rear end bearing in O.D. gear case

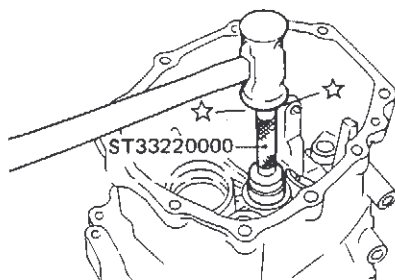

Be flush with front surface of O.D. gear case.

SMT391A

Counter gear rear bearing in adapter plate

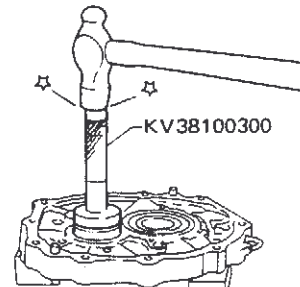

SMT395A

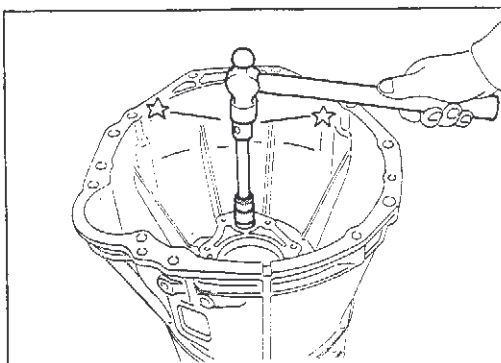

Slide ball bearing

- Use a drift [26 mm (1.02 in) outer diameter] to install the slide ball bearing flush in the case.

CAUTION:

Place a 19-mm (0.75 in) socket on the drift.

- Use the same method to install the adapter plate and rear extension slide ball bearing.

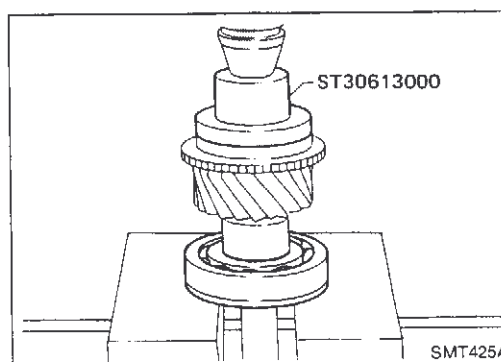

2. Install main drive gear bearing.
 - a. Press main drive gear bearing.
 - b. Install main drive gear spacer.

C2 MANUAL TRANSMISSION

3. Transmission Removal and Installation, Assembly and Disassembly (Cont'd)

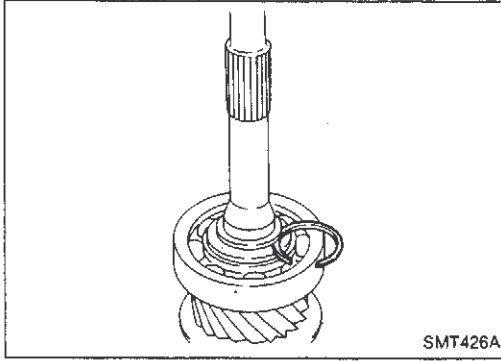

- c. Select proper main drive gear snap ring to minimize clearance of groove.

Allowable groove clearance:

0 - 0.1 mm (0 - 0.004 in)

Main drive gear snap ring

Thickness mm (in)	Part number
1.89 (0.0744)	32204-01G00
1.98 (0.0780)	32204-01G01
2.05 (0.0807)	32204-01G02
2.12 (0.0835)	32204-01G03
2.19 (0.0862)	32204-01G04

- d. Install selected snap ring on main drive gear

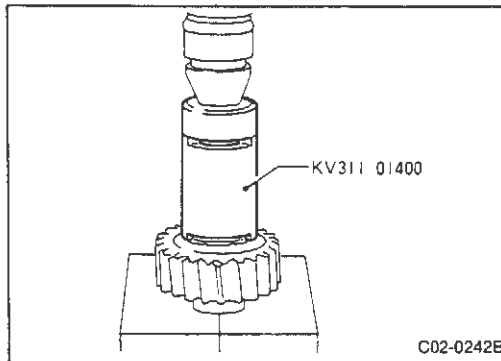

3. Install components on counter gear

- a. Reverse idler sub-gear assembly

- Assemble sub-gear on reverse idler gear as shown in figure. Use drift (special service tool) to press-fit snap ring.

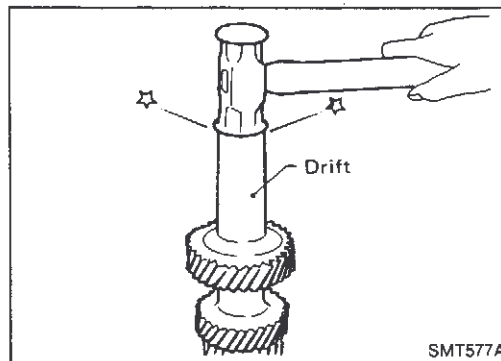

- b. Install sub-gear components.

When installing sub-gear snap ring, tap sub-gear snap ring into position on counter gear.

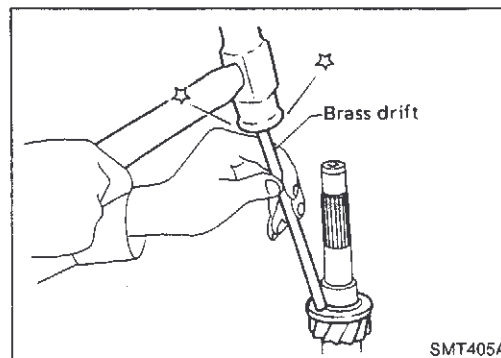

- c. Install counter gear rear thrust bearing.

C2 MANUAL TRANSMISSION

3. Transmission Removal and Installation, Assembly and Disassembly (Cont'd)

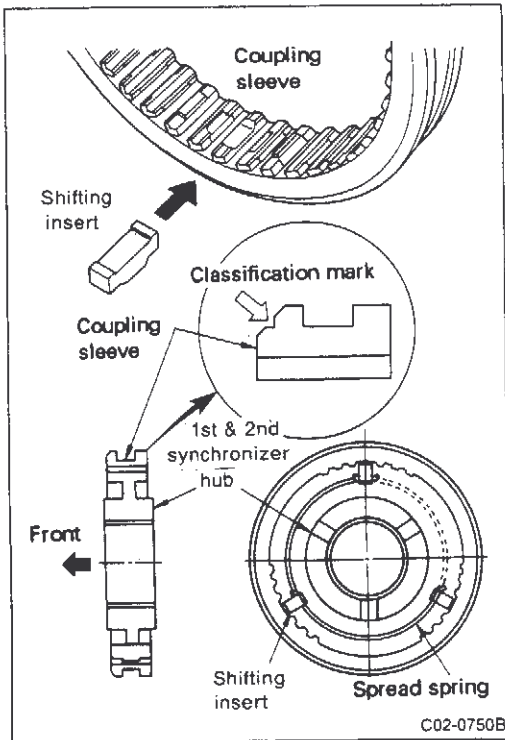

4. Install front side components on mainshaft.
 - a. 1st & 2nd synchronizer ASSY assembly
 - Assemble coupling sleeve, shifting insert and spread spring on 1st & 2nd synchronizer hub.

CAUTION:

- (1) Position spread spring end (side bent at angle) so it is engaged in inside groove.
- (2) Make sure the front and rear spread spring are not engaged in the same shifting insert.
- (3) Install the shifting insert in the position of the indentation in the coupling sleeve as shown in the figure.
- (4) Assemble the coupling sleeve with the groove facing the front.
- (5) Move hub and coupling sleeve by hand to make sure they move smoothly.

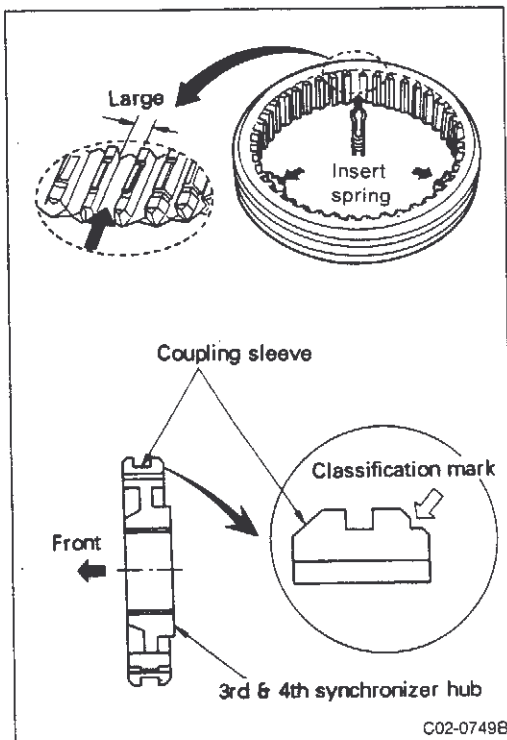

- b. 3rd & 4th synchronizer ASSY assembly
 - Assemble coupling sleeve and insert spring in 3rd & 4th synchronizer hub as shown in the figure.

CAUTION:

- (1) Assemble insert spring in groove of coupling sleeve as shown in figure.
- (2) Install synchronizer hub in direction indicated in figure.
- (3) Assemble coupling sleeve with groove facing the rear side.
- (4) Move hub and coupling sleeve by hand and check that they move smoothly.

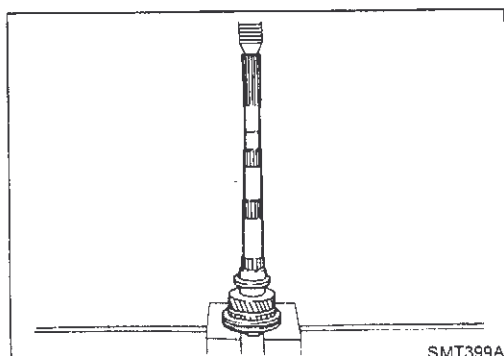

- c. Press on 3rd & 4th synchronizer assembly together with 3rd main gear and 3rd gear needle bearing.

Pay attention to direction of synchronizer assembly.

C2 MANUAL TRANSMISSION

3. Transmission Removal and Installation, Assembly and Disassembly (Cont'd)

- d. Select proper snap ring to minimize clearance of groove.
Allowable clearance of groove:
 0 - 0.1 mm (0 - 0.004 in)

Mainshaft front snap ring

Thickness mm (in)	Part number
1.89 (0.0744)	32204-01G00
1.98 (0.0780)	32204-01G01
2.05 (0.0807)	32204-01G02
2.12 (0.0835)	32204-01G03
2.19 (0.0862)	32204-01G04

- e. Install selected snap ring on mainshaft.

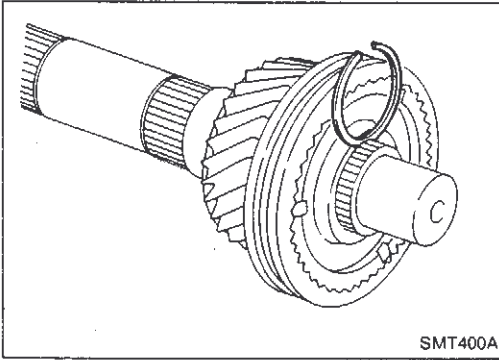

- f. Press on 1st & 2nd synchronizer assembly together with 2nd main gear and 2nd gear needle bearing.

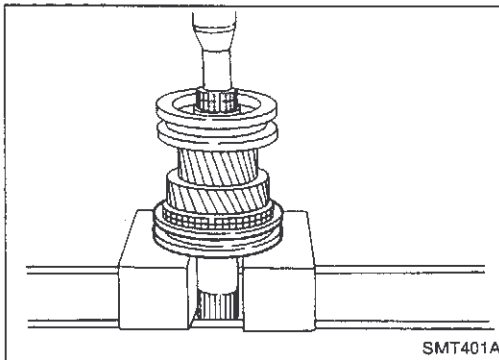

- g. Press on 1st gear bushing using 1st gear washer.
 h. Install 1st main gear and needle bearing.

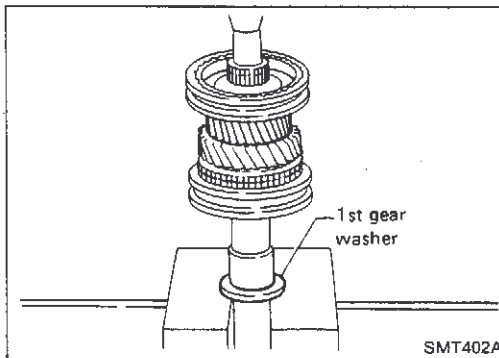

- i. Install steel ball and 1st gear washer.
Apply multi-purpose grease to steel ball and 1st gear washer before installing.

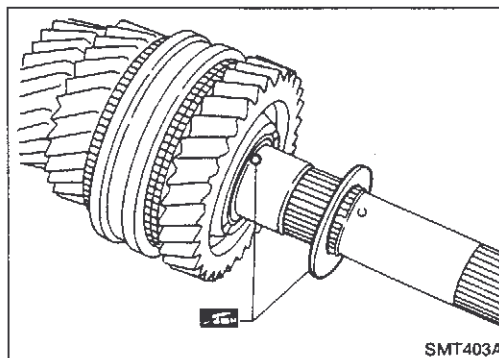

C2 MANUAL TRANSMISSION

3. Transmission Removal and Installation, Assembly and Disassembly (Cont'd)

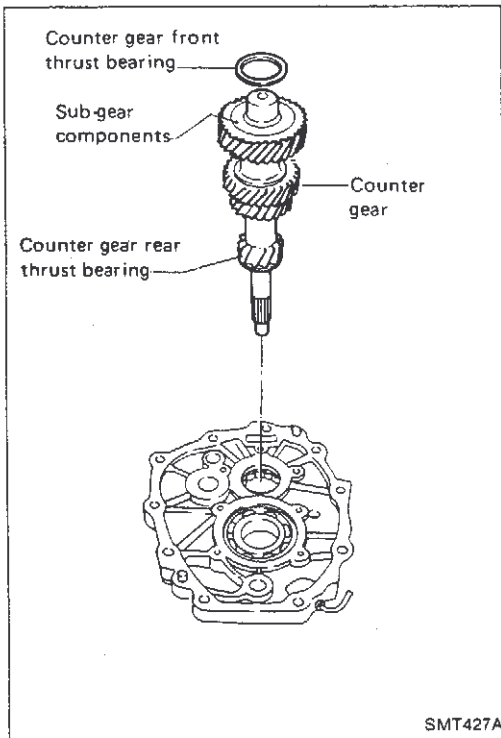

5. Select proper counter gear front bearing shim when replacing transmission case, counter gear, counter gear thrust bearing or sub-gear components.
 - a. Install counter gear with sub-gear components, counter gear front and rear thrust bearing on adapter plate.
 - b. Remove counter gear front bearing shim from transmission case.
 - c. Place adapter plate and counter gear assembly in transmission case (case inverted).

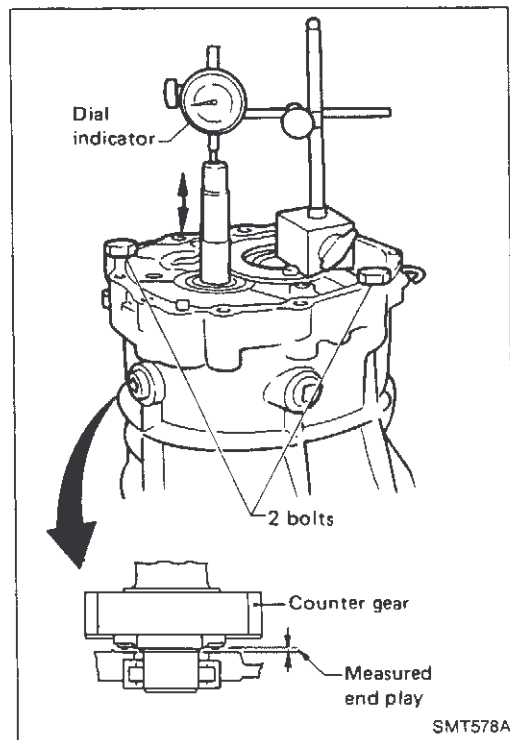

- d. Tighten adapter plate to transmission case with 2 bolts.
- e. Place dial indicator on rear end of counter gear.
- f. Move counter gear up and down and measure dial indicator deflection.
- g. Select proper shim using table below as a guide.

Counter gear end play:

0.10 - 0.25 mm (0.0039 - 0.0098 in)

Table for selecting proper counter gear front bearing shim

Dial indicator deflection mm (in)	Thickness of correct washer mm (in)	Part number
0.93 - 1.02 (0.0366 - 0.0402)	0.88 (0.0346)	32218-01G11
1.03 - 1.12 (0.0406 - 0.0441)	0.96 (0.0378)	32218-01G12
1.13 - 1.22 (0.0445 - 0.0480)	1.04 (0.0409)	32218-01G13
1.23 - 1.32 (0.0484 - 0.0520)	1.12 (0.0441)	32218-01G14
1.33 - 1.42 (0.0524 - 0.0559)	1.28 (0.0504)	32218-01G15
1.43 - 1.52 (0.0563 - 0.0598)	1.36 (0.0535)	32218-01G16
1.53 - 1.62 (0.0602 - 0.0638)	1.44 (0.0567)	32218-01G17

C2 MANUAL TRANSMISSION

3. Transmission Removal and Installation, Assembly and Disassembly (Cont'd)

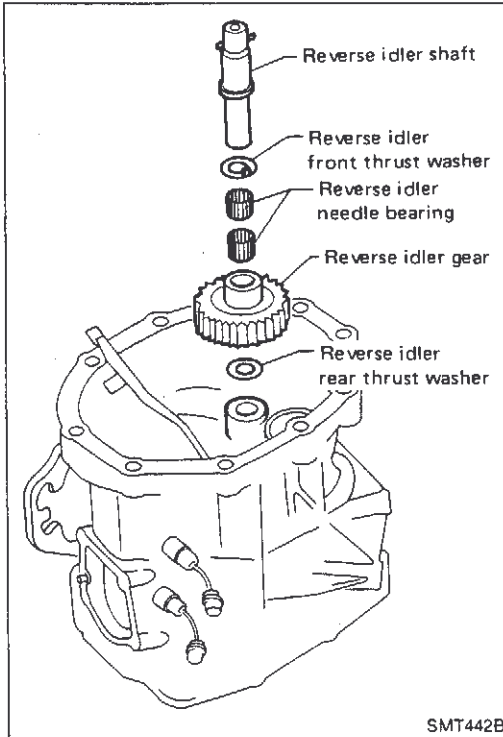

6. Select proper reverse idler rear thrust washer when replacing O.D. gear case, reverse idler gear, reverse idler shaft or reverse idler thrust washer.
 - a. Install reverse idler gear, reverse idler needle bearings, reverse idler thrust washers and reverse idler shaft into O.D. gear case.

When replacing reverse idler rear washer, install either A or B. Reverse idler rear thrust washer

	Thickness mm (in)	Part number
A	1.97 (0.0776)	32284-01G10
B	2.07 (0.0815)	32284-01G11

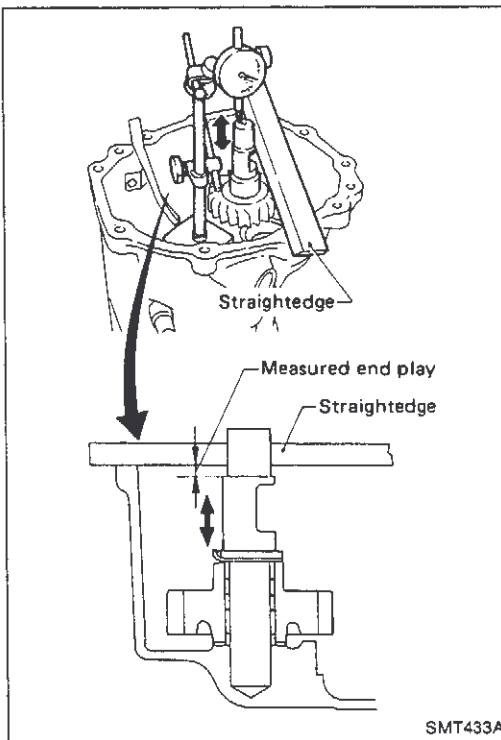

- b. Place dial indicator on front end of reverse idler shaft.
- c. Put straightedge on front surface of O.D. gear case as a stopper for reverse idler shaft.
- d. Move reverse idler shaft up and down and measure reverse idler gear end play.

Reverse idler gear end play:

0.30 - 0.53 mm (0.0118 - 0.0209 in)

- e. If not within specification, replace reverse idler rear thrust washer with the other (A or B) and check again.

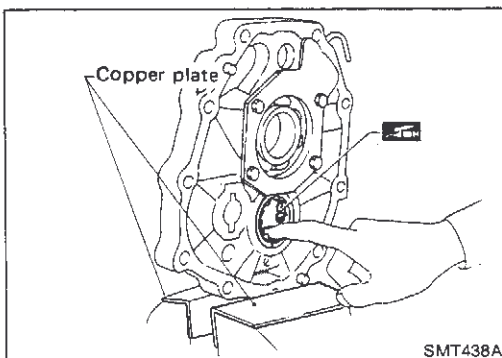

7. Install mainshaft and counter gear on adapter plate and main drive gear on mainshaft.
 - a. Mount adapter plate on vise and apply multi-purpose grease to counter gear rear bearing.

C2 MANUAL TRANSMISSION

3. Transmission Removal and Installation, Assembly and Disassembly (Cont'd)

b. Install mainshaft partially on mainshaft front bearing.

To enable counter gear installation, do not install mainshaft completely.

c. Install counter gear on counter gear rear bearing and install main drive gear, pilot bearing and spacer on mainshaft.

When installing counter gear into counter gear rear bearing, push up on upper roller of counter gear rear bearing with screwdriver.

d. Install mainshaft and counter gear completely by tapping rear side of adapter plate and pulling mainshaft.

8. Install rear side components on mainshaft and counter gear.

a. Install O.D. gear bushing while pushing on the front of counter gear.

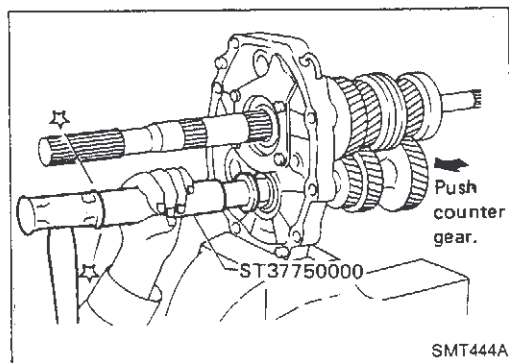
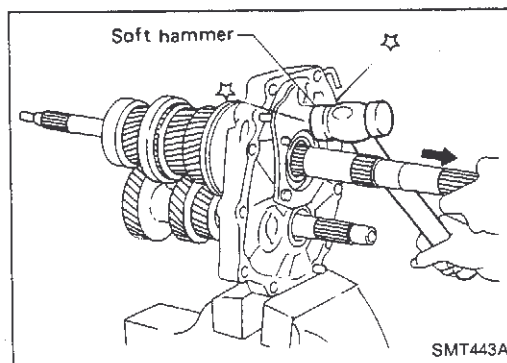
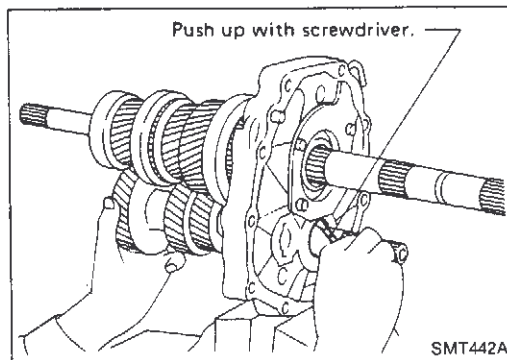
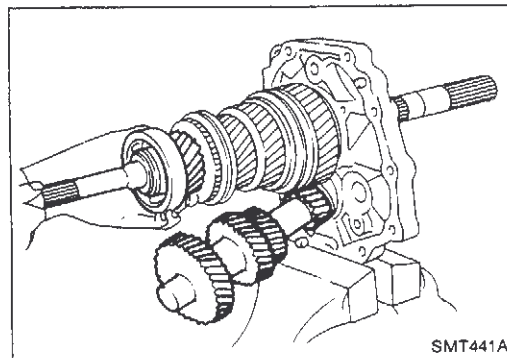
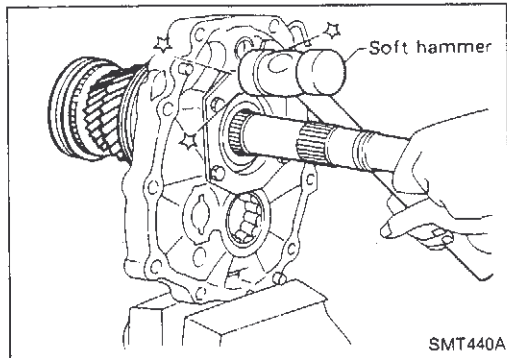

C2 MANUAL TRANSMISSION

3. Transmission Removal and Installation, Assembly and Disassembly (Cont'd)

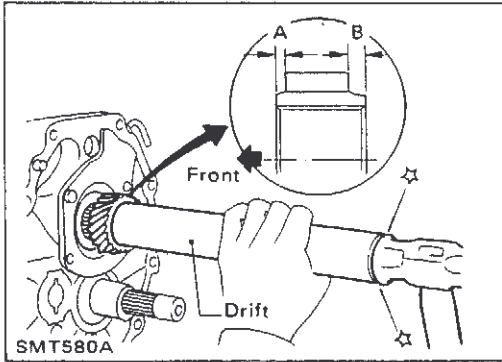

b. Install O.D. main gear

Pay attention to direction of O.D. main gear (B is wider than A as shown at left)

c. Install adapter plate with gear assembly into transmission case.

d. Install O.D. gear needle bearing and then install O.D. counter gear and reverse idler shaft.

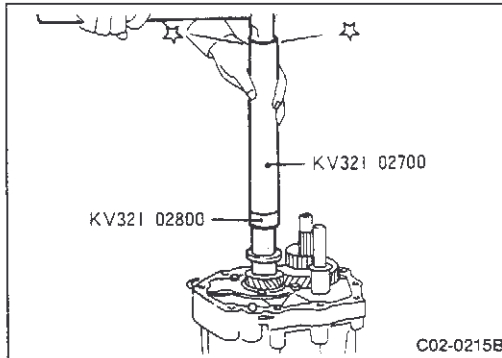

e. Install reverse gear bushing

- Install steel ball in mainshaft.

- Use a drift (special service tool) and install reverse gear bushing.

CAUTION:

Align steel ball in reverse gear bushing indentation and press-fit to install.

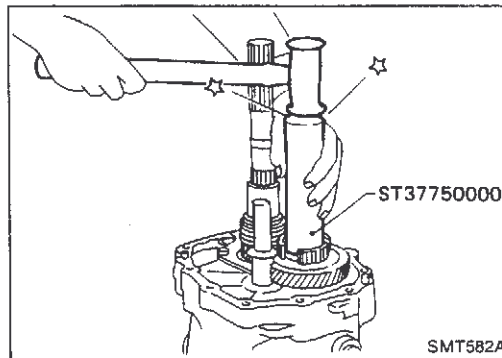

f. Install reverse cone.

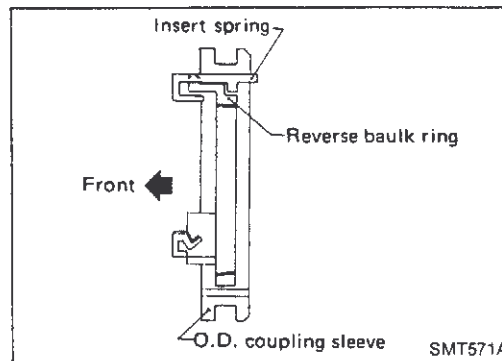

g. Install insert springs and reverse baulk ring on O.D. coupling sleeve. Then install them and O.D. baulk ring on O.D. counter gear.

Pay attention to direction of O.D. coupling sleeve.

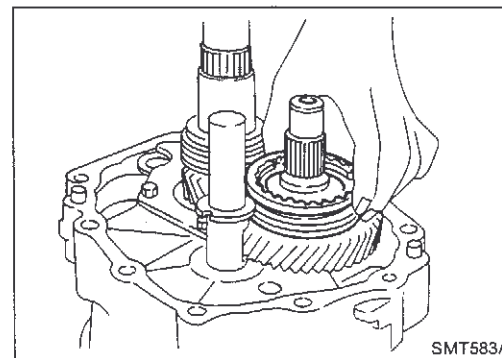

C2 MANUAL TRANSMISSION

3. Transmission Removal and Installation, Assembly and Disassembly (Cont'd)

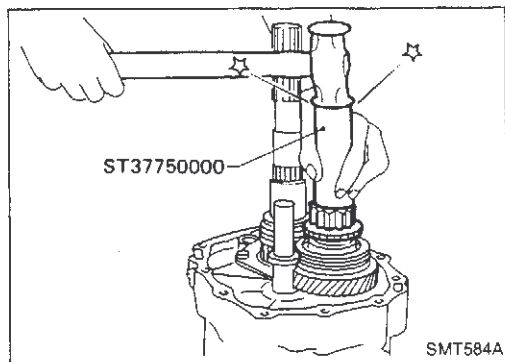

- h. Install reverse counter gear.
- i. Install reverse gear needle bearing and then install reverse main gear, reverse idler gear and reverse idler thrust washers.

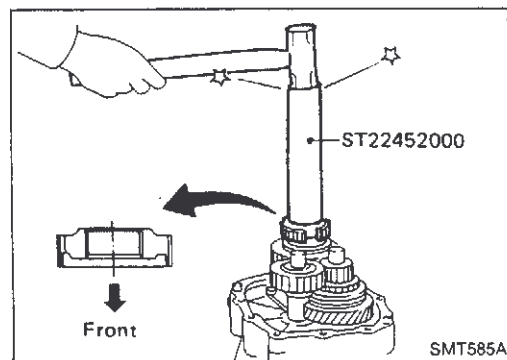

- j. Install reverse hub.
Pay attention to its direction.

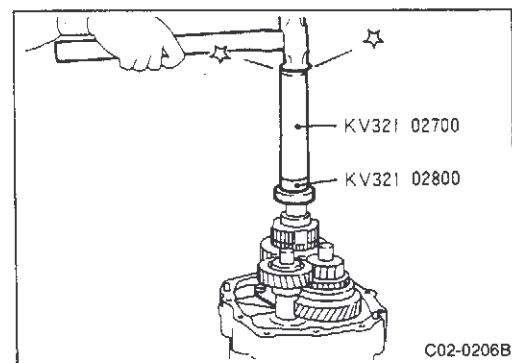

- k. Use drift (special service tool) to install mainshaft spacer and mainshaft rear gear bearing.

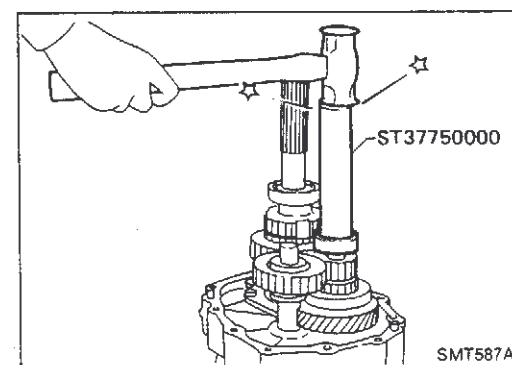

- l. Install counter gear rear end bearing.
- m. Separate adapter plate from transmission case and mount adapter plate on vice again.

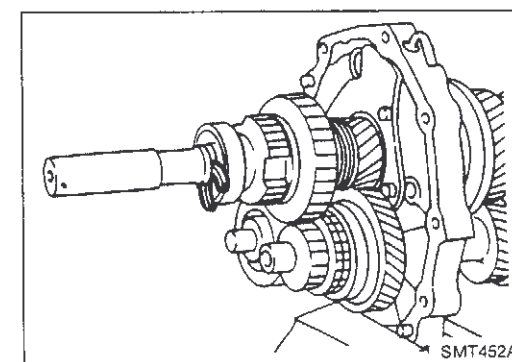

C2 MANUAL TRANSMISSION

3. Transmission Removal and Installation, Assembly and Disassembly (Cont'd)

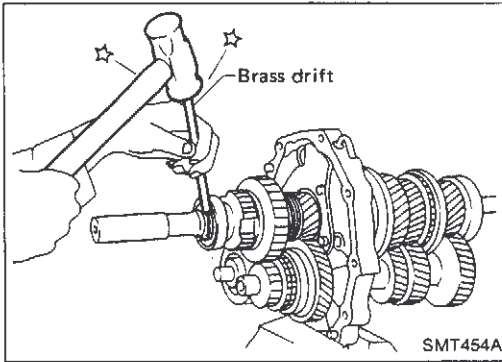

- n. Select proper mainshaft C-ring to minimize clearance of groove.

**Allowable clearance of groove:
0 - 0.1 mm (0 - 0.004 in)**

Thickness mm (in)	Part Number	Thickness mm (in)	Part Number
2.63 (0.1035)	32348-01G15	3.19 (0.1256)	32348-01G07
2.70 (0.1063)	32348-01G00	3.26 (0.1283)	32348-01G08
2.77 (0.1091)	32348-01G01	3.33 (0.1311)	32348-01G09
2.84 (0.1118)	32348-01G02	3.40 (0.1339)	32348-01G10
2.91 (0.1146)	32348-01G03	3.47 (0.1366)	32348-01G11
2.98 (0.1173)	32348-01G04	3.54 (0.1394)	32348-01G12
3.05 (0.1201)	32348-01G05	3.61 (0.1421)	32348-01G13
3.12 (0.1228)	32348-01G06	3.68 (0.1449)	32348-01G14

- o. Install selected C-ring, C-ring holder and mainshaft rear snap ring.

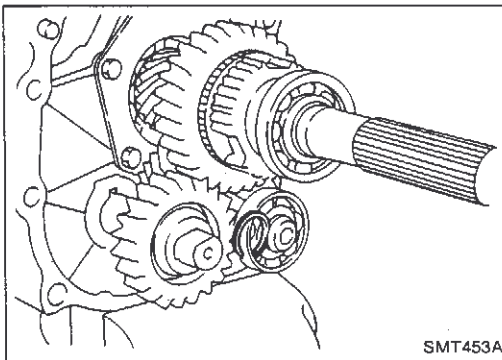

- p. Install spacer and then select proper counter gear rear snap ring to minimize clearance of groove.

**Allowable clearance of groove:
0 - 0.1 mm (0 - 0.004 in)**

Counter gear rear snap ring

Thickness mm (in)	Part number
1.26 (0.0496)	32236-01G08
1.32 (0.0520)	32236-01G00
1.38 (0.0543)	32236-01G01
1.44 (0.0567)	32236-01G02
1.50 (0.0591)	32236-01G03
1.56 (0.0614)	32236-01G04
1.62 (0.0638)	32236-01G05
1.68 (0.0661)	32236-01G06
1.74 (0.0685)	32236-01G07

- q. Install selected counter gear rear snap ring.

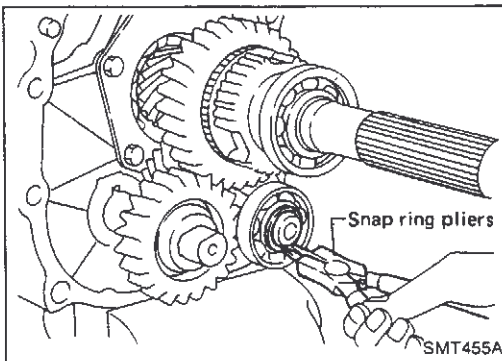

- r. Install reverse coupling sleeve.

Pay attention to its direction.

- s. Measure each gear end play as a final check. Refer to "DISASSEMBLY".

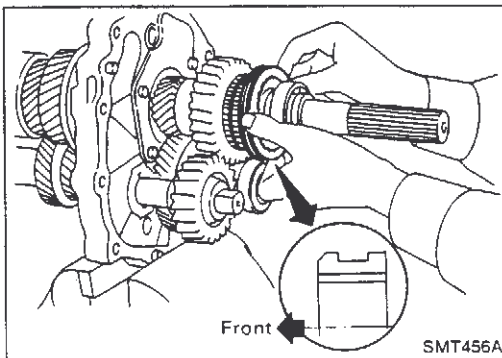

C2 MANUAL TRANSMISSION

3. Transmission Removal and Installation, Assembly and Disassembly (Cont'd)

SHIFT CONTROL COMPONENTS ASSEMBLY

1. Install O.D. fork rod and O.D. shift fork. Then install retaining pin into O.D. shift fork.
2. Install 1st & 2nd, 3rd & 4th and reverse shift fork in coupling sleeve.

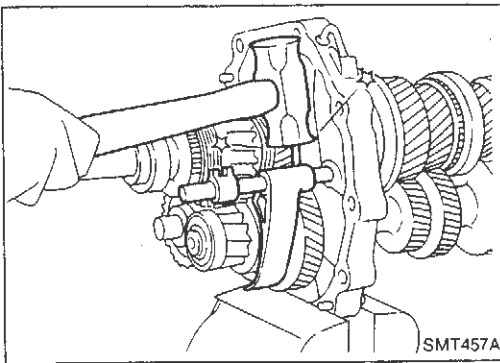

3. Install striking rod into hole of shift forks, striking lever and interlock and then install retaining pin into striking lever.

Make sure that striking rod moves smoothly.

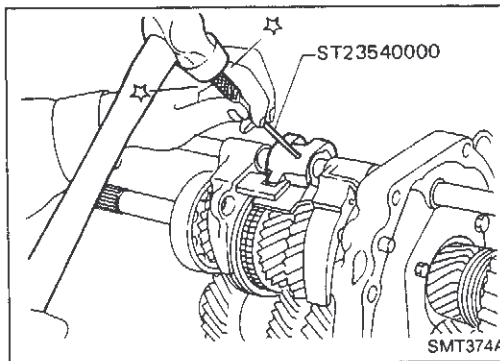

- Install 5th & reverse fork rod in reverse fork.
- Install check ball, return spring and check ball plug.

CAUTION:

- (1) Coat check ball plug screw with sealing material.
- (2) Make sure that striking rod moves smoothly.

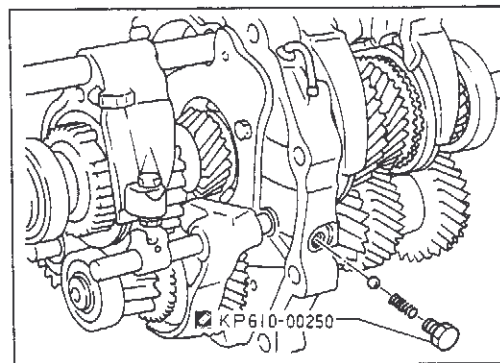

CASE COMPONENTS ASSEMBLY

1. Install front cover oil seal.
Apply multi-purpose grease to seal lip.
2. Install selected counter gear front bearing shim into transmission case.

Apply multi-purpose grease.

3. Apply sealant to mating surface of transmission case.

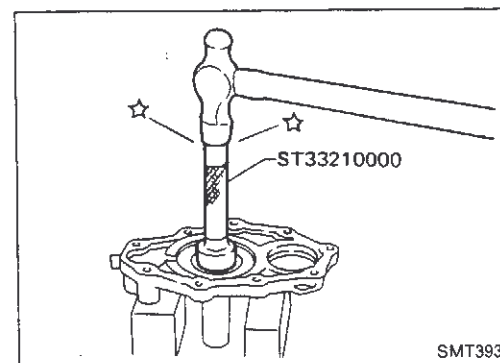

4. Install gear assembly in transmission case.
5. Install check spring and check ball into interlock stopper.
Apply multi-purpose grease to check ball.

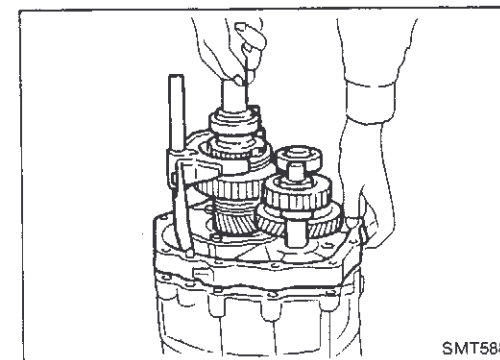

C2 MANUAL TRANSMISSION

3. Transmission Removal and Installation, Assembly and Disassembly (Cont'd)

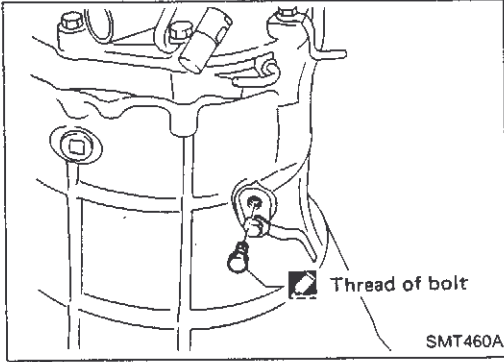

6. Install interlock stopper assembly and then tighten check ball plug.

Apply sealant to thread of check ball plug.

7. Install stopper ring and main drive bearing snap ring.

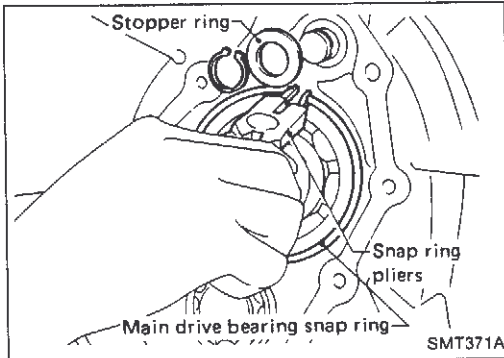

8. Install front cover and gasket.

Apply sealant to thread of 3 bolts shown left.

9. Apply sealant to mating surface of adapter plate.

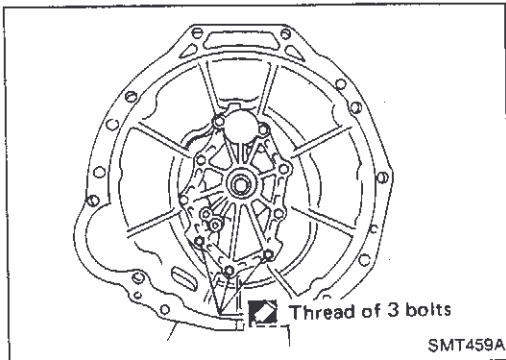

REAR EXTENSION ASSEMBLY

- Use a drift to align mainshaft rear end bearing in case end surface and install in O.D. cover.

CAUTION:

Press-fit bearing in direction shown in left figure so bearing end surface is even with case end.

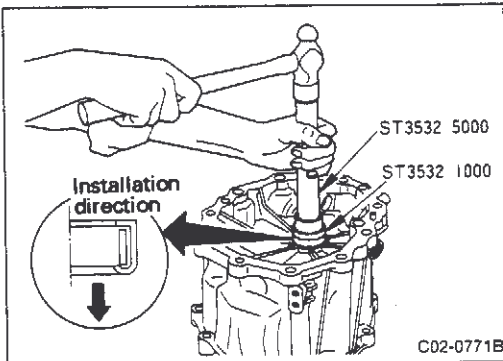

- Coat O.D. cover mating surface with sealant.

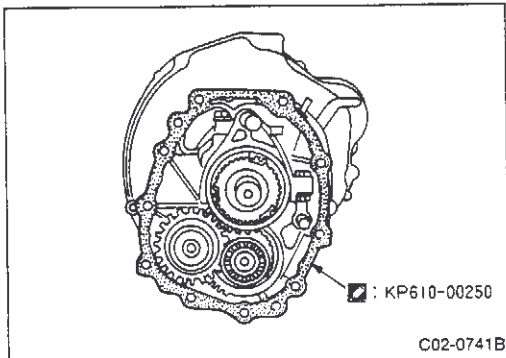

C2 MANUAL TRANSMISSION

3. Transmission Removal and Installation, Assembly and Disassembly (Cont'd)

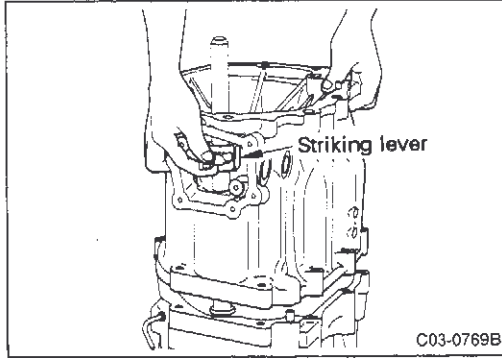

- Install striking lever and rear extension at same time as shown in figure.

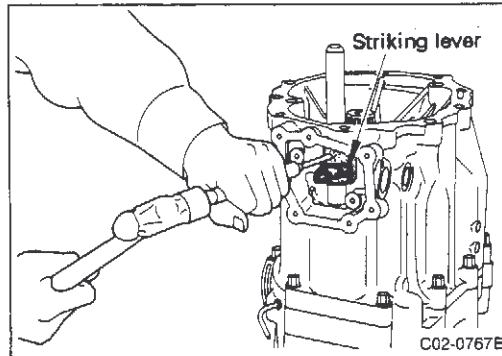

- Use pin punch (special service tool) to install retaining pin in striking lever.

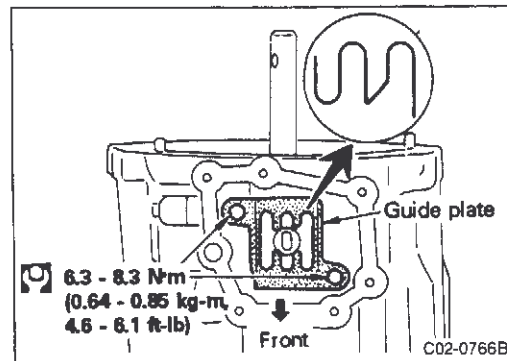

- Align guide plate installation direction and tighten bolts to specified torque.

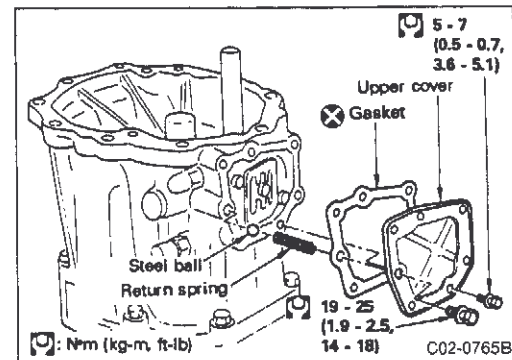

- Install reverse check, select check plunger and spring.

CAUTION:

Coat threads of select check plug with sealant.

- Install neutral switch and reverse lamp switch.

CAUTION:

Coat threads of each switch with sealant.

- Assemble return spring and check ball. Install upper cover and gasket.

CAUTION:

Coat return spring bolts with sealant.

C2 MANUAL TRANSMISSION

3. Transmission Removal and Installation, Assembly and Disassembly (Cont'd)

One-way valve installation

- Insert the one-way valve in the front of the adapter plate so the notches on both sides engage.

CAUTION:

After installing the one-way valve, check that valve operates as shown in figure.

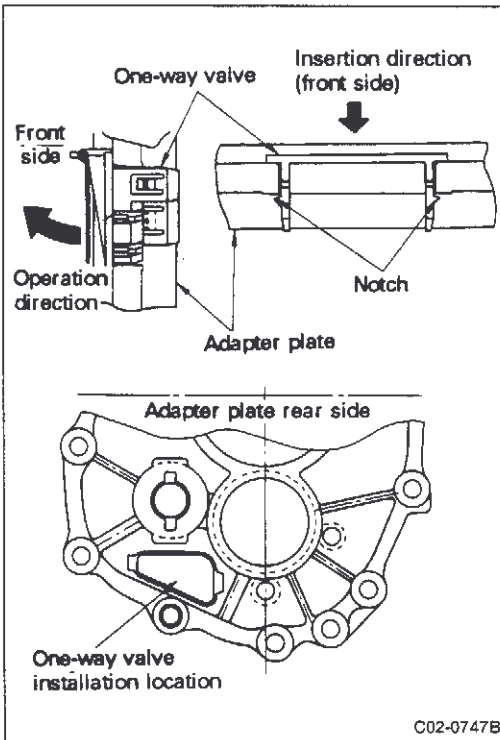

C3 ELECTRICAL CONTROL TORQUE SPLIT 4WD SYSTEM (ATTESSA E-TS)

OPERATION PRECAUTIONS

- Only use genuine Nissan special power steering fluid for the E-TS operation fluid.
- Only use automatic transmission fluid D for the transfer lubrication fluid.
- Never reuse the E-TS operation oil or transfer fluid.
- Do not allow dust or foreign matter to enter the system when installing or removing hydraulic unit, piping or transfer unit.
- Use a torque wrench to tighten bolts and nuts.

SPECIAL SERVICE TOOLS

Tool name Tool number	Description
Oil seal puller ST3329 0001	<p>C00-0138</p>
Drift ST2786 2000	<p>C00-0246</p>
Drift KV401 048S0 KV401 04810 KV401 04820 KV401 04830 KV401 04840 KV401 04850	<p>KV401 04830</p> <p>C00-0267</p>
Oil pressure gauge KV481 03500 (former ST2909 1000)	<p>C00-0042</p>
Oil pressure gauge adapter KV481 00410 ① KV481 00410-1 ② KV481 00400-2	<p>C00-0238</p>
Drift KV401 047S0 KV401 04710 KV401 04720-1 KV401 04720-2 KV401 04730	<p>C00-0160</p>

C3 ELECTRICAL CONTROL TORQUE SPLIT 4WD SYSTEM (ATTESSA E-TS)

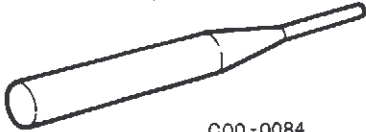
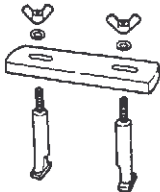
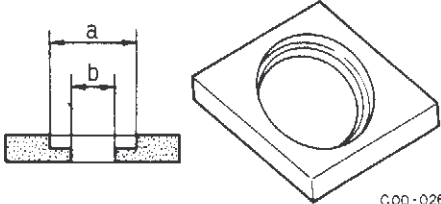
Tool name Tool number	Description	
Pin punch KV321 01100 6 mm (0.24 in)	 C00-0084	Striking arm and striking lever removal and installation
Spring compressor KV311 01100	 C00-0268	Clutch drum snap ring removal and installation
Bearing replacer ST3006 1000	 C00-0269	Release bearing removal

COMMERCIAL SERVICE TOOLS

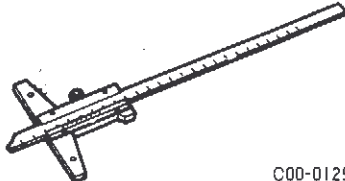
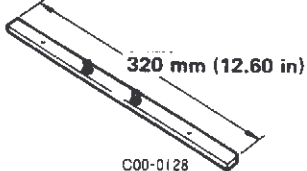
Tool name Tool number	Description	
Depth gauge (calipers type) GG9229	 C00-0129	Clutch hub end play measurement
Span GG9230 0320 320 mm (12.60 in)	 C00-0128	Clutch hub end play measurement
Depth gauge (micrometer type)		Oil pump side clearance measurement
Flange wrench HT7278		Companion flange removal
Puller HT7235		Front drive sprocket, spacer, companion flange removal

C3 ELECTRICAL CONTROL TORQUE SPLIT 4WD SYSTEM (ATTESSA E-TS)

1. Summary

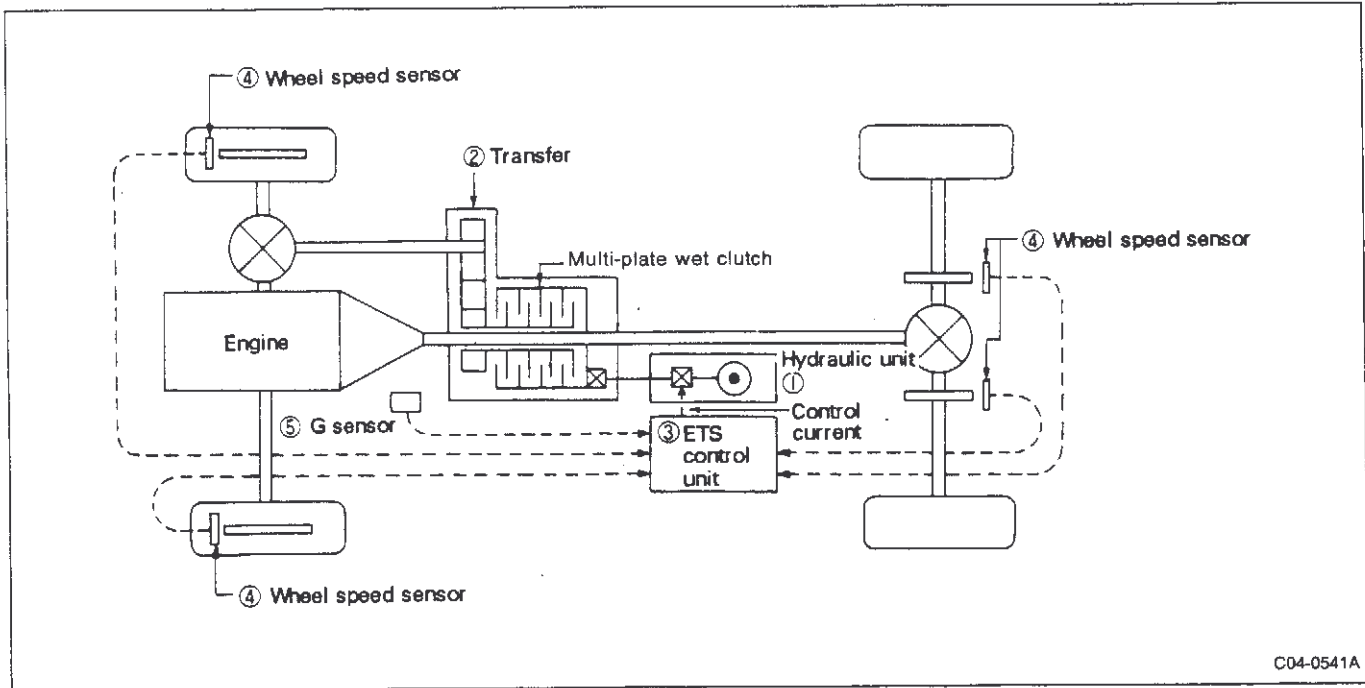

Specifications

Hydraulic control	Hydraulic power	Electric pump (proportional electromagnetic pressure reduction is equipped internally).
	Control pressure	0 - 1,569 kPa (0 - 16 kg/cm ² , 0 - 228 psi)
	Operation oil	Nissan special power steering fluid
Transfer	Engine specifications	RB26DETT
	Transmission specifications	M/T
	Model No. (33100)	05U00
	Model	ETX13A
	Front wheel control system	Torque-split by wet multi-plate clutch
	Lubrication system	Oil pump
	Speedometer pinion gear (drive/driven)	6/20
Oil type and volume	ℓ (Imp qt)	Nissanmatic fluid D [approx. 1.8 (1-5/8)]

C3 ELECTRICAL CONTROL TORQUE SPLIT 4WD SYSTEM (ATTESSA E-TS)

1. Summary (Cont'd)

Inspection standard values

Transfer

Unit: mm (in)

Description	Standard value																											
Clutch hub end play	0.2 - 0.35 (0.0079 - 0.0138)																											
Multi-plate clutch end play	0.2 - 0.5 (0.008 - 0.020)																											
Pump inner and outer gear side clearance	0.02 - 0.04 (0.0008 - 0.0016)																											
Clutch hub bearing shim	<table border="1"> <thead> <tr> <th>Part number</th> <th>Shim thickness</th> </tr> </thead> <tbody> <tr> <td>33112 05U04</td> <td>0.40 (0.0157)</td> </tr> <tr> <td>33112 05U05</td> <td>0.50 (0.0197)</td> </tr> <tr> <td>33112 05U00</td> <td>0.60 (0.0236)</td> </tr> <tr> <td>33112 05U01</td> <td>0.70 (0.0276)</td> </tr> <tr> <td>33112 05U02</td> <td>0.80 (0.0315)</td> </tr> <tr> <td>33112 05U03</td> <td>0.90 (0.0354)</td> </tr> <tr> <td>33112 05U06</td> <td>1.00 (0.0394)</td> </tr> </tbody> </table>		Part number	Shim thickness	33112 05U04	0.40 (0.0157)	33112 05U05	0.50 (0.0197)	33112 05U00	0.60 (0.0236)	33112 05U01	0.70 (0.0276)	33112 05U02	0.80 (0.0315)	33112 05U03	0.90 (0.0354)	33112 05U06	1.00 (0.0394)										
	Part number	Shim thickness																										
	33112 05U04	0.40 (0.0157)																										
	33112 05U05	0.50 (0.0197)																										
	33112 05U00	0.60 (0.0236)																										
	33112 05U01	0.70 (0.0276)																										
	33112 05U02	0.80 (0.0315)																										
	33112 05U03	0.90 (0.0354)																										
33112 05U06	1.00 (0.0394)																											
Retainer plate	<table border="1"> <thead> <tr> <th>Part number</th> <th>Retainer plate thickness</th> </tr> </thead> <tbody> <tr> <td>31537 05U00</td> <td>4.8 (0.189)</td> </tr> <tr> <td>31537 05U01</td> <td>5.0 (0.197)</td> </tr> <tr> <td>31537 05U02</td> <td>5.2 (0.205)</td> </tr> <tr> <td>31537 05U03</td> <td>5.4 (0.213)</td> </tr> <tr> <td>31537 05U04</td> <td>5.6 (0.220)</td> </tr> <tr> <td>31537 05U05</td> <td>5.8 (0.228)</td> </tr> <tr> <td>31537 05U06</td> <td>6.0 (0.236)</td> </tr> <tr> <td>31537 05U07</td> <td>6.2 (0.244)</td> </tr> <tr> <td>31537 05U08</td> <td>6.4 (0.252)</td> </tr> <tr> <td>31537 05U09</td> <td>6.6 (0.260)</td> </tr> <tr> <td>31537 05U10</td> <td>6.8 (0.268)</td> </tr> <tr> <td>31537 05U11</td> <td>7.0 (0.276)</td> </tr> </tbody> </table>		Part number	Retainer plate thickness	31537 05U00	4.8 (0.189)	31537 05U01	5.0 (0.197)	31537 05U02	5.2 (0.205)	31537 05U03	5.4 (0.213)	31537 05U04	5.6 (0.220)	31537 05U05	5.8 (0.228)	31537 05U06	6.0 (0.236)	31537 05U07	6.2 (0.244)	31537 05U08	6.4 (0.252)	31537 05U09	6.6 (0.260)	31537 05U10	6.8 (0.268)	31537 05U11	7.0 (0.276)
	Part number	Retainer plate thickness																										
	31537 05U00	4.8 (0.189)																										
	31537 05U01	5.0 (0.197)																										
	31537 05U02	5.2 (0.205)																										
	31537 05U03	5.4 (0.213)																										
	31537 05U04	5.6 (0.220)																										
	31537 05U05	5.8 (0.228)																										
	31537 05U06	6.0 (0.236)																										
	31537 05U07	6.2 (0.244)																										
	31537 05U08	6.4 (0.252)																										
	31537 05U09	6.6 (0.260)																										
	31537 05U10	6.8 (0.268)																										
31537 05U11	7.0 (0.276)																											
Pump gear (Use set of inner and outer gears which are the same thickness.)	<table border="1"> <thead> <tr> <th colspan="2">Part number</th> <th rowspan="2">Gear thickness</th> </tr> <tr> <th>Inner gear</th> <th>Outer gear</th> </tr> </thead> <tbody> <tr> <td>31346 05U02</td> <td>31347 05U02</td> <td>6.98 (0.2748)</td> </tr> <tr> <td>31346 05U01</td> <td>31347 05U01</td> <td>6.99 (0.2752)</td> </tr> <tr> <td>31346 05U00</td> <td>31347 05U00</td> <td>7.00 (0.2756)</td> </tr> </tbody> </table>		Part number		Gear thickness	Inner gear	Outer gear	31346 05U02	31347 05U02	6.98 (0.2748)	31346 05U01	31347 05U01	6.99 (0.2752)	31346 05U00	31347 05U00	7.00 (0.2756)												
	Part number		Gear thickness																									
	Inner gear	Outer gear																										
	31346 05U02	31347 05U02	6.98 (0.2748)																									
31346 05U01	31347 05U01	6.99 (0.2752)																										
31346 05U00	31347 05U00	7.00 (0.2756)																										

C3 ELECTRICAL CONTROL TORQUE SPLIT 4WD SYSTEM (ATTESSA E-TS)

2. On-vehicle Inspection and Adjustment

2-1 4WD FUNCTION INSPECTION

- Move the car so the front and rear wheels are positioned on the free rollers.
- In vehicles equipped with M/T, set selector in 2nd gear and release clutch in 2nd gear at low speed so a speed of 20 km/h (12 MPH) is reached.
- Check speed of all four wheels visually. Make sure front and rear wheels are moving at approximately the same speed.

CAUTION:

Perform inspection when vehicle is in 2WD mode. Refer to "3. ETS Troubleshooting" when front wheel speed is noticeably slower than rear wheel speed (the front wheels may move slowly due to the oil viscosity in the transfer unit even in the 2WD mode).

2-2 OIL LEAK INSPECTION

Operation precautions

- ① Determine the type of oil where the leak occurs. (The ETS operation oil uses genuine Nissan power steering fluid special.)
- ② When location of the oil leak is not clear, clean the area with white gasoline and check the oil leak location again. (Do not clean the hydraulic unit or harness connectors directly with white gasoline or other cleaning solvent. If the white gasoline or solvents contact any of these parts, wipe it off immediately.)
- ③ Check parts of related systems during repair. Replace defective parts as necessary.
- ④ Replace the entire hydraulic unit ASSY if oil leaks occur because the unit cannot be disassembled.

(1) Leak inspection

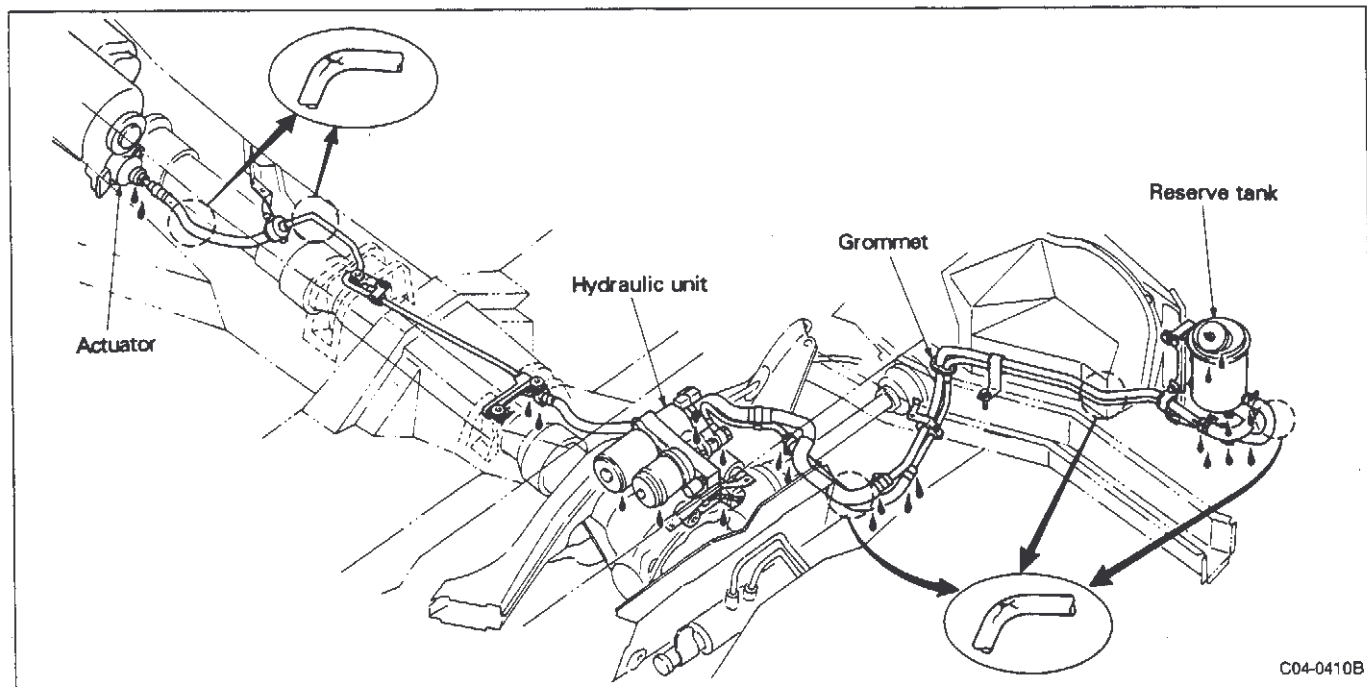

C3 ELECTRICAL CONTROL TORQUE SPLIT 4WD SYSTEM (ATTESSA E-TS)

2. On-vehicle Inspection and Adjustment (Cont'd)

Check oil leak location. (Note)

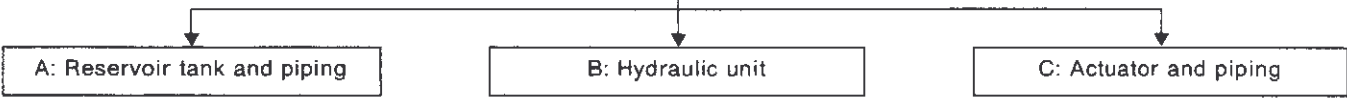

Note: When the leak location is unclear, clean the area with white gasoline and check leak location again.

Oil leak location	A: Reservoir tank and piping	B: Hydraulic unit	C: Actuator and piping
Service description (replacement part)	<ul style="list-style-type: none"> Reservoir tank ASSY Tube and hose 	<ul style="list-style-type: none"> Hydraulic unit ASSY 	<ul style="list-style-type: none"> Actuator ASSY Tubes and hoses
Parts requiring inspection	<ul style="list-style-type: none"> Reservoir tank cap damage 	<ul style="list-style-type: none"> Air bleeder damage 	<ul style="list-style-type: none"> Air bleeder damage Transfer oil quantity (mixed with oil leak from actuator)
Service procedures		Remove from vehicle. (Note 1) ↓ Replace part. ↓ Install in vehicle. ↓ Bleed air, check oil level. ↓ Check for oil leaks. (Note 2)	

NOTE 1: Refer to "4-4 HYDRAULIC UNIT AND RESERVOIR TANK" for installation and removal procedures.

NOTE 2: Refer to "[Point 3] Air bleeding" in "4-4 HYDRAULIC UNIT AND RESERVOIR TANK" for air bleeding and oil level inspection.

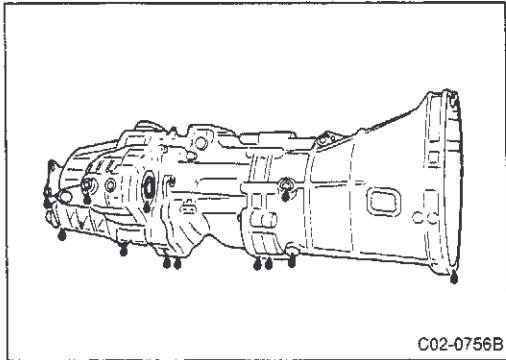

(2) Transfer

- When there is an oil leak at either front or rear oil seal, replace parts as necessary with unit installed in vehicle.
- When there is oil leak at actuator, leave unit in vehicle and replace parts as necessary.
- When there are oil leaks in other locations, remove transfer ASSY from vehicle and replace parts as necessary.

C3 ELECTRICAL CONTROL TORQUE SPLIT 4WD SYSTEM (ATTESSA E-TS)

2. On-vehicle Inspection and Adjustment (Cont'd)

2-3 OIL LEVEL INSPECTION

(1) Hydraulic unit

- Set ignition switch ON and check that oil level is between MAX-MIN in reservoir tank.

CAUTION:

- (1) Reservoir tank is installed inside trunk on right side.
 - (2) If ignition switch is turned OFF for a long period of time, the oil in accumulator may return to reservoir tank, causing volume to exceed MAX level. For this reason, the oil level must be checked when the ignition switch is ON.
 - (3) Only use genuine Nissan Power Steering Fluid Special.
- There must be no oil leaks around reservoir tank.

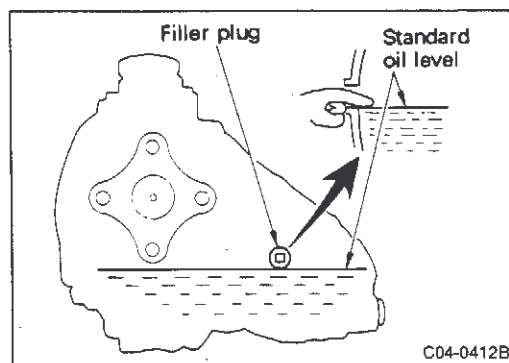
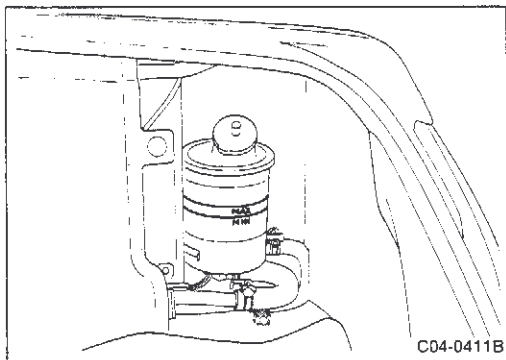

(2) Transfer

- Check the oil level through the filler plug hole.

CAUTION:

Only use genuine Nissan Automatic Fluid D.

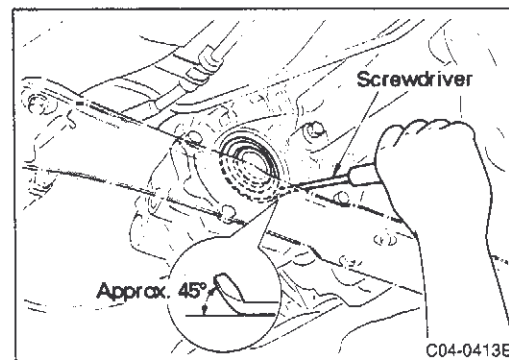

2-4 TRANSFER OIL SEAL REPLACEMENT

(1) Front oil seal replacement

Removal

- Drain oil from transfer case.
- Remove clutch operating cylinder.
- Remove front propeller shaft.
- Place end of screwdriver at 45° angle and turn in metal part of oil seal evenly on diagonal line as shown in figure to remove seal.

Installation

- Use a drift (special service tool) and tap the end of a suitable sized socket to insert seal.
- Install propeller shaft and tighten bolts and nuts to specified torque.

Front propeller shaft tightening torque:

24 - 32 N·m (2.4 - 3.3 kg·m, 17 - 24 ft·lb)

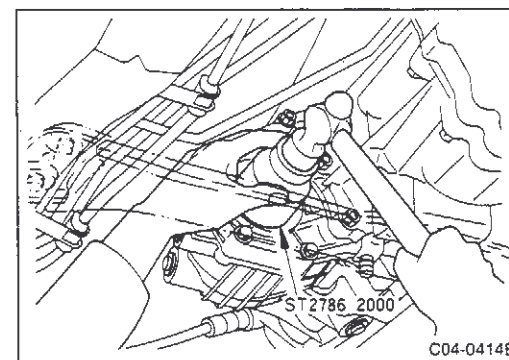

C3 ELECTRICAL CONTROL TORQUE SPLIT 4WD SYSTEM (ATTESSA E-TS)

2. On-vehicle Inspection and Adjustment (Cont'd)

(2) Rear oil seal replacement

Removal

- Remove rear propeller shaft.
- Attach flange wrench (HT7278) to companion flange and remove flange nut.

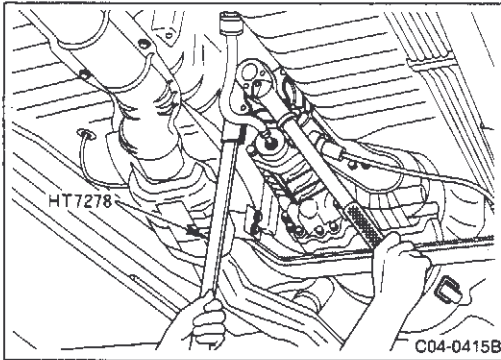

- Set gear puller (commercial service tool) on companion flange and remove flange.

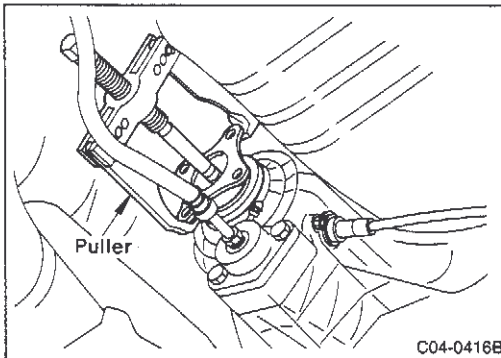

- Attach oil seal puller (special service tool) and remove transfer rear oil seal.

Reference: Use KV381 054S0 in oil seal puller ASSY.

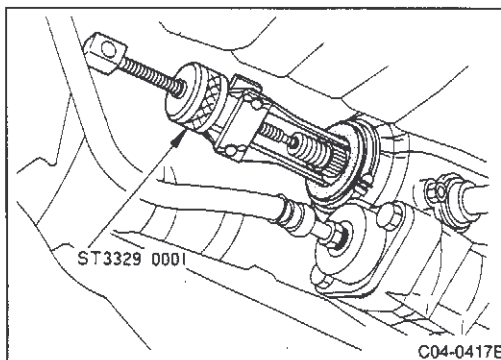

Installation

- Use drift (special service tool) and install oil seal in case end.

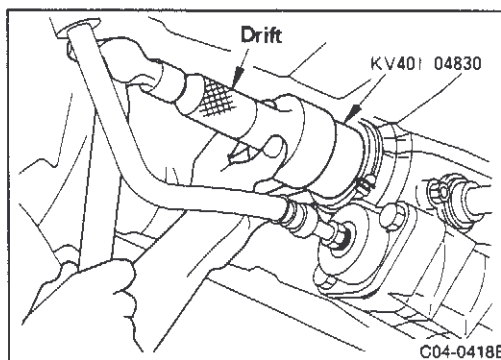

- Install companion flange. Use flange wrench (HT7278) to tighten nut to specified tightening torque.

CAUTION:

- (1) If oil seal sliding part of companion flange has scratches in axle direction, replace companion flange.
- (2) The flange nut must be replaced after each disassembly. Use a new part and tighten to specified torque.

Companion flange nut tightening torque:

226 - 324 N·m (23.0 - 33.0 kg-m, 166 - 239 ft-lb)

- Install propeller shaft and tighten bolts and nuts to specified torque.

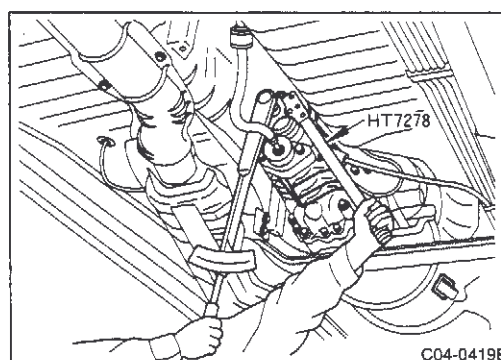

C3 ELECTRICAL CONTROL TORQUE SPLIT 4WD SYSTEM (ATTESSA E-TS)

2. On-vehicle Inspection and Adjustment (Cont'd)

Propeller shaft tightening torque:

Flange

88 - 98 N·m (9.0 - 10.0 kg-m, 65 - 72 ft-lb)

Constant velocity joint section

64 - 74 N·m (6.5 - 7.5 kg-m, 47 - 54 ft-lb)

C3 ELECTRICAL CONTROL TORQUE SPLIT 4WD SYSTEM (ATTESSA E-TS)

3. Troubleshooting

3-1 ELECTRICAL SYSTEM TROUBLESHOOTING

(1) Circuit diagram

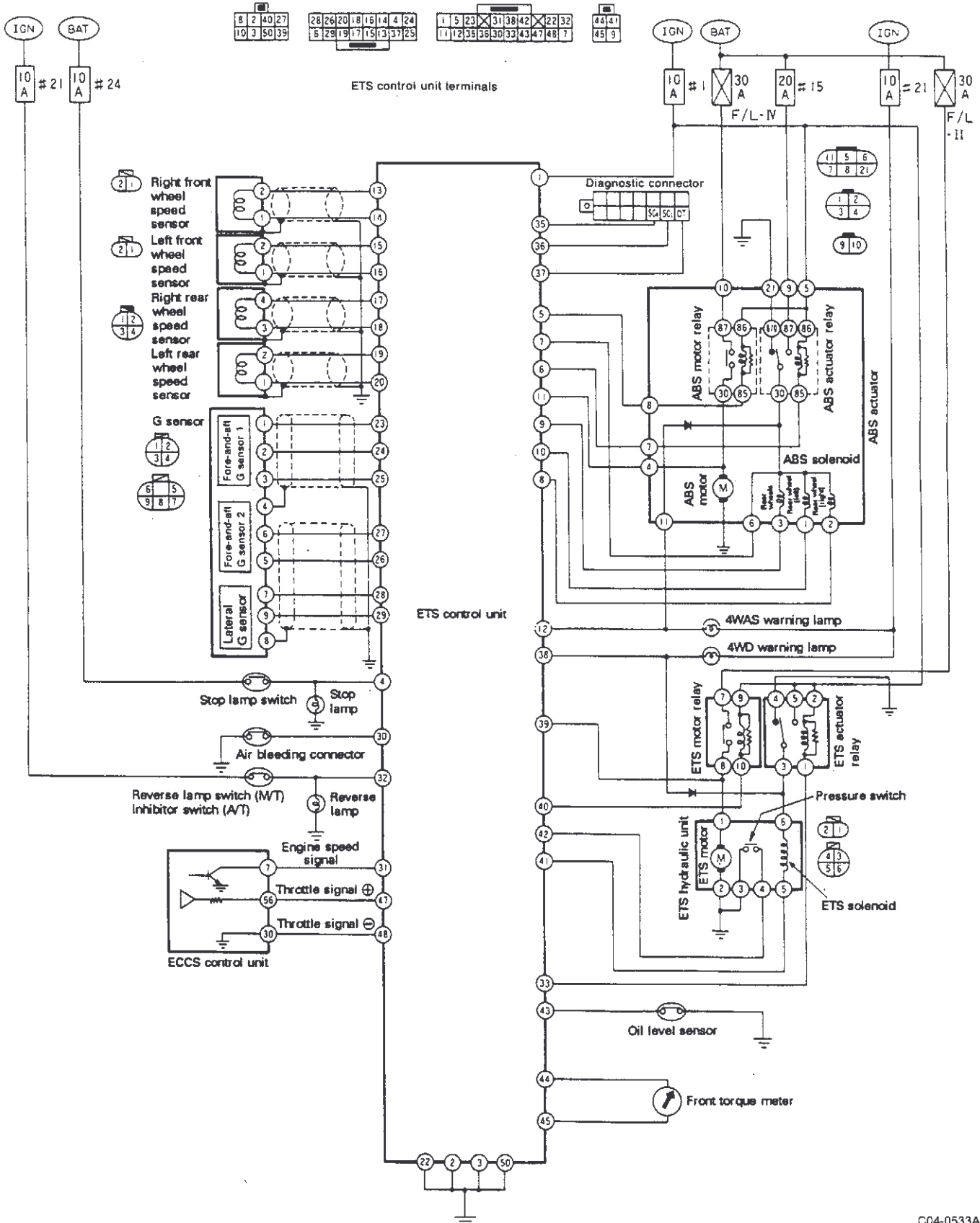

C3 ELECTRICAL CONTROL TORQUE SPLIT 4WD SYSTEM (ATTESSA E-TS)

3. Troubleshooting (Cont'd)

(2) When CONSULT is not used



(a) Self-diagnosis procedures

- If ETS system is normal, the 4WD warning lamp lights when ignition switch is turned ON. The lamp turns off within 1 second after engine starts. If warning lamp does not go off, LED lamp in the ETS control unit below the rear parcel shelf will flash to indicate the abnormal position.
- The warning lamp lights and LED light flashes continuously when ignition switch is not turned OFF even after damaged area is corrected. For this reason, turn ignition switch OFF one time after repair is completed and then check self-diagnosis results again. When more than two systems are faulty, the LED will flash a set number of times to indicate each problem location.

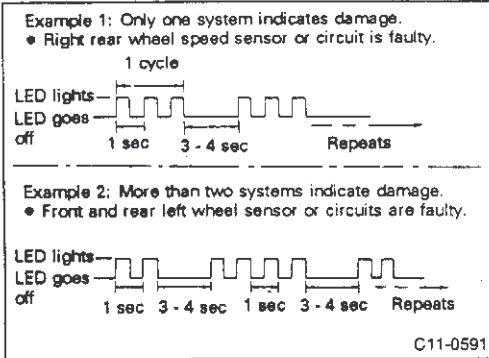
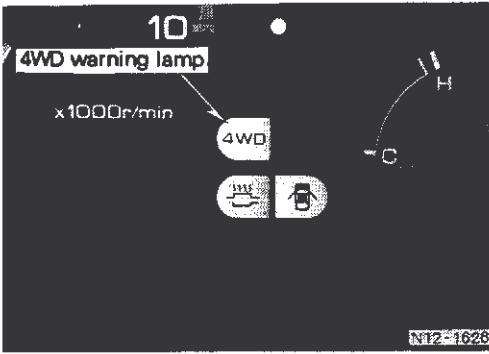

Diagnosis locations are indicated below.

Number of LED flashes	Damage location	Detection cycle		Warning lamp		Flow chart (Note 3)
		Engine start time	Driving	4WAS	4WD	
1	Right front wheel speed sensor or circuit	○ (Note 1)	○	○	○	A
2	Left front wheel speed sensor or circuit	○ (Note 1)	○	○	○	B
3	Right rear wheel speed sensor or circuit	○ (Note 1)	○	○	○	C
4	Left rear wheel speed sensor or circuit	○ (Note 1)	○	○	○	D
5	ABS right front wheel actuator solenoid or circuit	○	○	○		*
6	ABS left front wheel actuator solenoid or circuit	○	○	○		*
7	ABS rear wheel actuator solenoid or circuit	○	○	○		*
8	ABS actuator motor, motor relay or circuit	○	○	○		*
9	ABS actuator relay or circuit	○	○	○		*
10	ETS control unit power supply or circuit	○	○	○		*
11	Fore-and-aft G sensor 1 or circuit	○	○	○	○	E
12	Fore-and-aft G sensor 2 or circuit	○	○	○	○	F
13	Fore-and-aft G sensor 1, fore-and-aft G sensor 2	○	○	○	○	G
14	G sensor power supply 1 or circuit	○	○	○	○	H
15	G sensor power supply 2 or circuit	○	○	○	○	I
16	Lateral G sensor or circuit	○	○	○	○	J
17	Air bleed connector or circuit		○		○ (Note 2)	K
18	ETS pressure switch or circuit	○	○		○	L
19	ETS motor, motor relay or circuit	○	○		○	M

C3 ELECTRICAL CONTROL TORQUE SPLIT 4WD SYSTEM (ATTESSA E-TS)

3. Troubleshooting (Cont'd)

Number of LED flashes	Damage location	Detection cycle		Warning lamp		Flow chart (Note 3)
		Engine start time	Driving	4WAS	4WD	
20	ETS solenoid or circuit	○	○		○	N
21	Throttle sensor or circuit	○	○		○	O
22	ETS oil level switch or circuit	○	○		○	P
23	—	—	—	—	—	—
24 or continually ON or OFF	ETS control unit, ground or circuit	○	○	○	○	Q

Note: (1) Detection may not be possible due to sensor short circuit problem.

(2) 4WD warning lamp lights during driving but normal control is possible.

(3) Refer to "C10 Brakes, 3. Troubleshooting" for items indicated by an asterisk (*).

C3 ELECTRICAL CONTROL TORQUE SPLIT 4WD SYSTEM (ATTESSA E-TS)

3. Troubleshooting (Cont'd)

(b) When warning lamp display is abnormal

A. Ignition switch is ON (before starting engine) but 4WD warning lamp does not light.

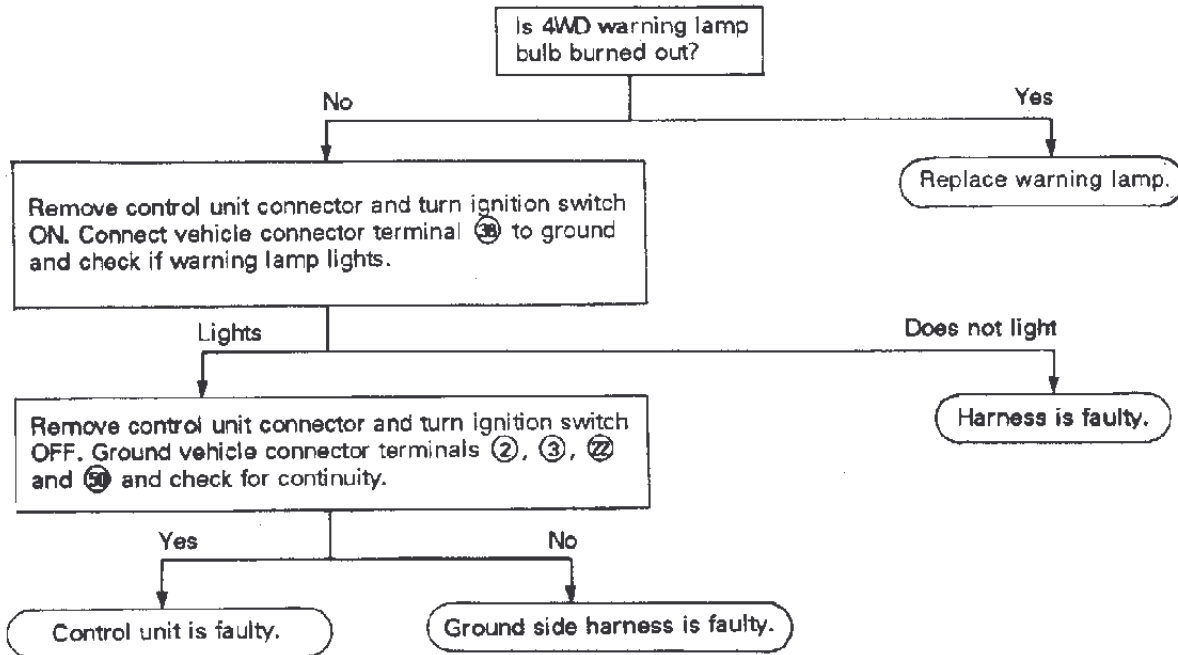

ETS control unit terminals (vehicle harness side)

C03-3934 B

B. Ignition switch is ON (before starting engine) but 4WAS warning lamp and 4WD warning lamp do not light.

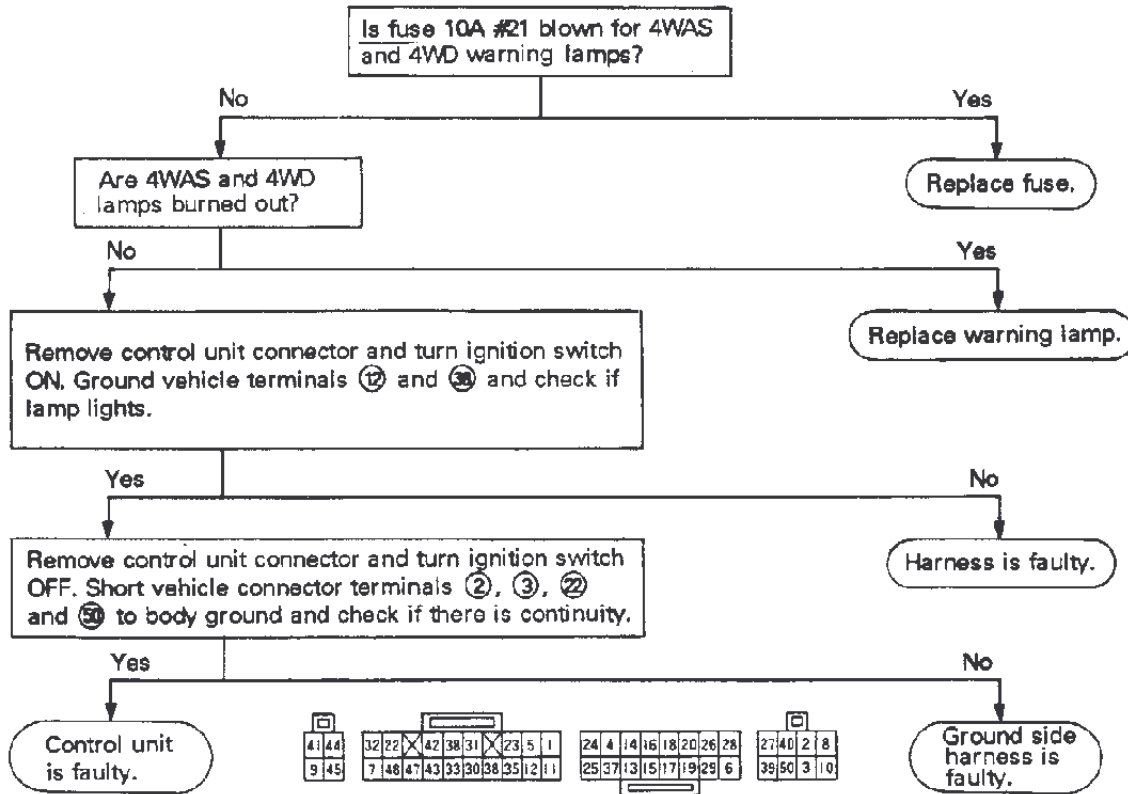

ETS control unit terminals (vehicle harness side)

C03-3935 B

C3 ELECTRICAL CONTROL TORQUE SPLIT 4WD SYSTEM (ATTESSA E-TS)

3. Troubleshooting (Cont'd)

(3) Troubleshooting flowchart

- A. Right front wheel sensor or circuit problem (LED flashes 1 time)
- B. Left front wheel sensor or circuit problem (LED flashes 2 times)
- C. Right rear wheel sensor or circuit problem (LED flashes 3 times)
- D. Left rear wheel sensor or circuit problem (LED flashes 4 times)

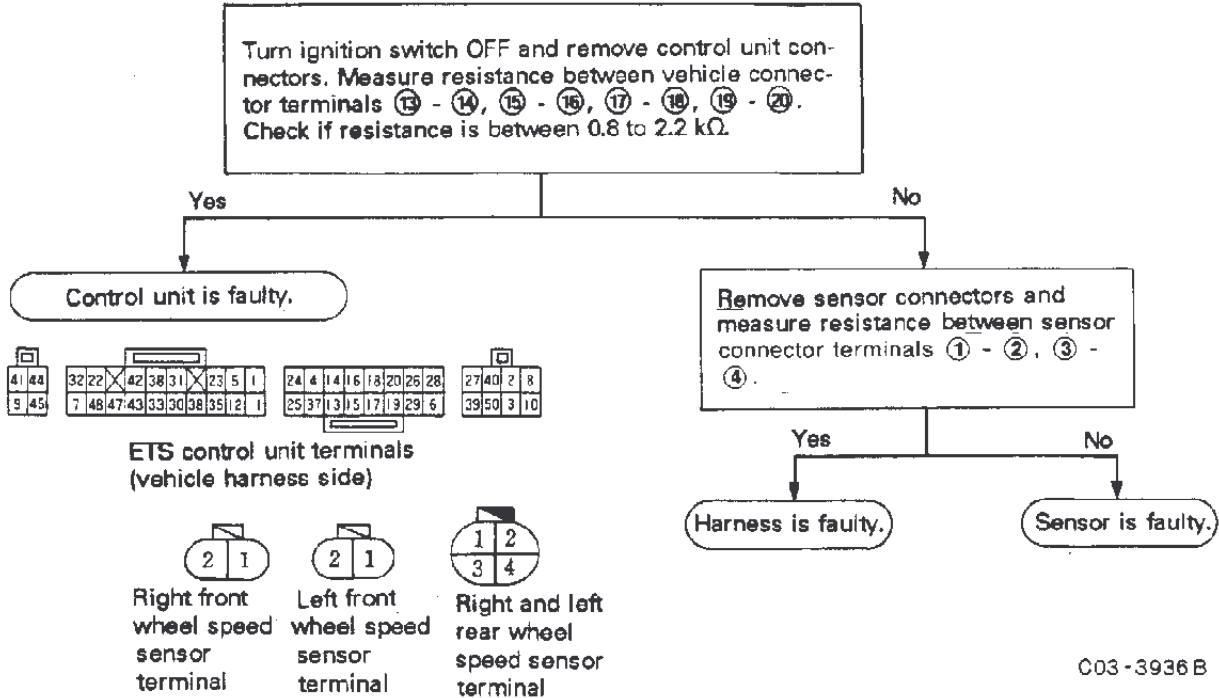

- E. Fore-and-aft G sensor 1 or circuit problem (LED flashes 11 times)
- F. Fore-and-aft G sensor 2 or circuit problem (LED flashes 12 times)
- G. Fore-and-aft G sensor 1, 2 or circuit problem (LED flashes 13 times)

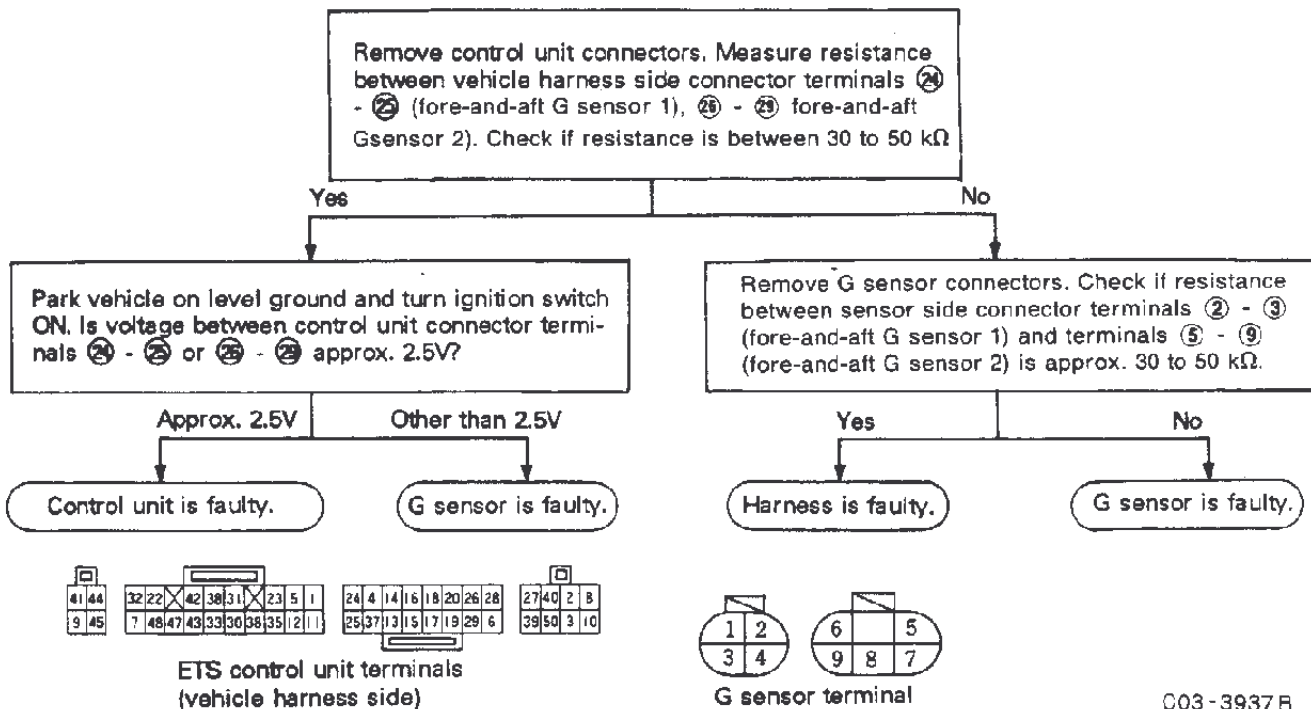

C3 ELECTRICAL CONTROL TORQUE SPLIT 4WD SYSTEM (ATTESSA E-TS)

3. Troubleshooting (Cont'd)

- H. G sensor power circuit 1 or circuit problem (LED flashes 14 times)
- I. G sensor power circuit 2 or circuit problem (LED flashes 15 times)

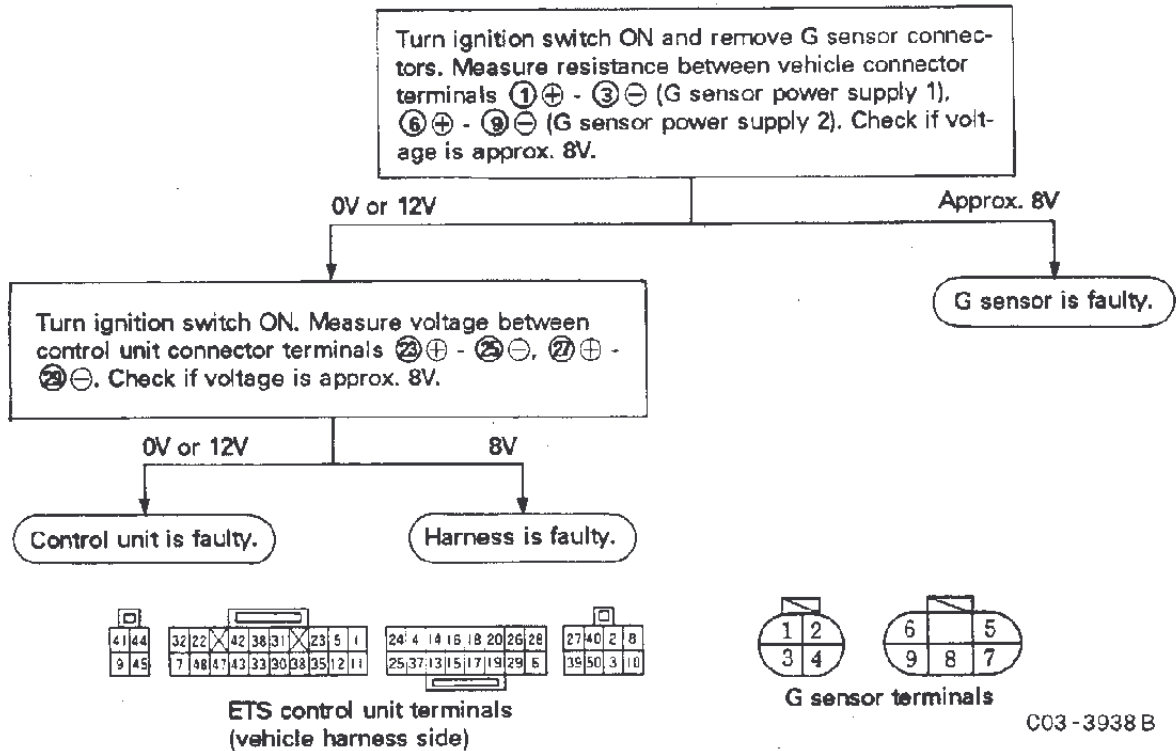

- J. Lateral G sensor or circuit problem (LED flashes 16 times)

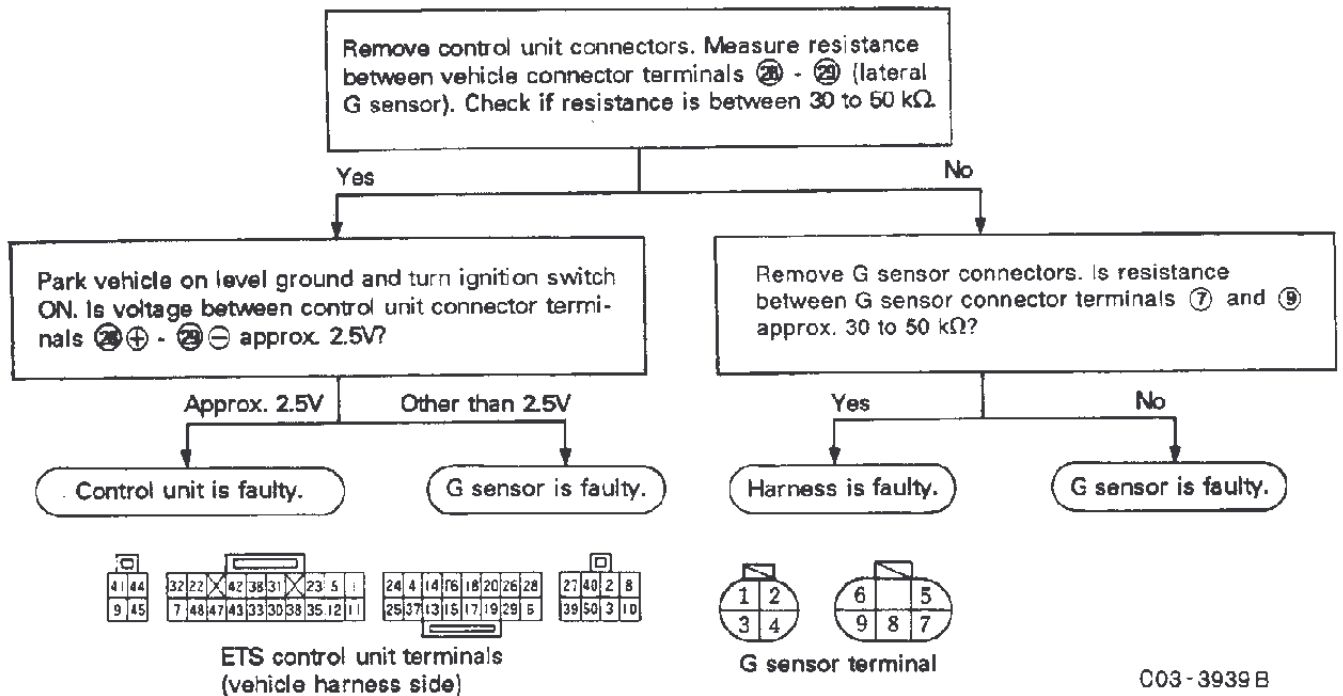

C3 ELECTRICAL CONTROL TORQUE SPLIT 4WD SYSTEM (ATTESSA E-TS)

3. Troubleshooting (Cont'd)

K. Air bleeder connector and circuit (LED flashes 17 times)

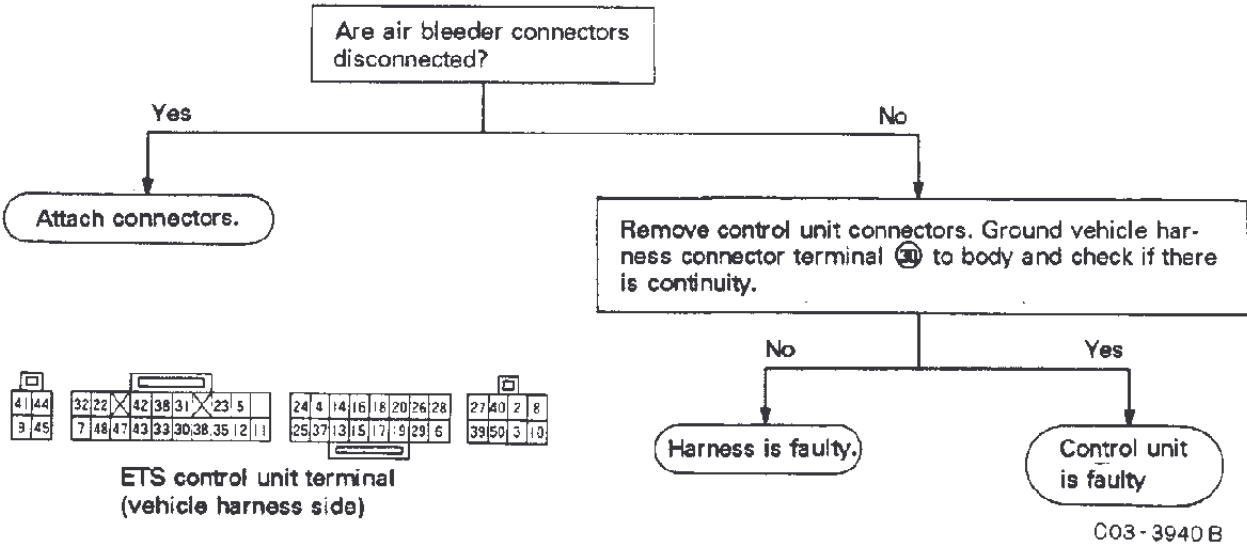

L. Pressure switch and circuit (LED flashes 18 times)

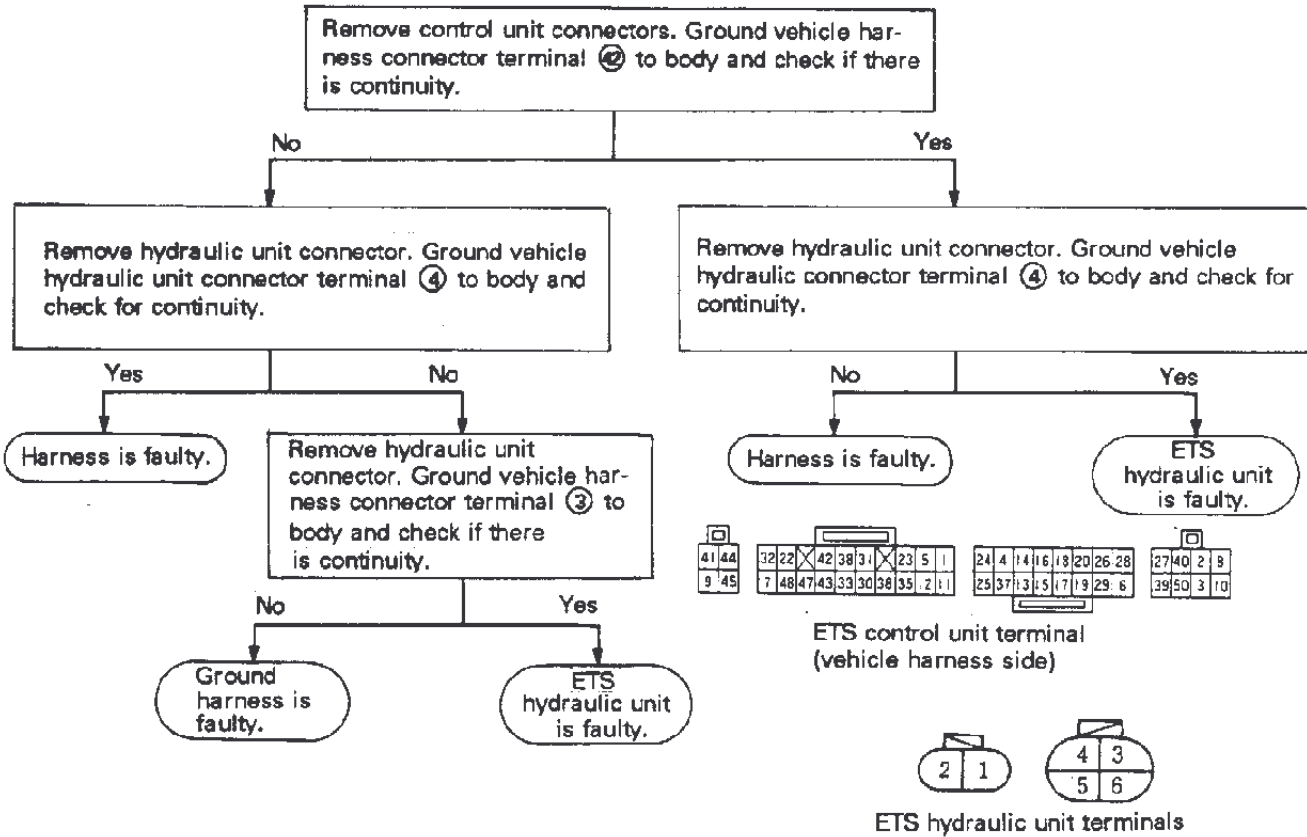

C3 ELECTRICAL CONTROL TORQUE SPLIT 4WD SYSTEM (ATTESSA E-TS)

3. Troubleshooting (Cont'd)

M. ETS motor, motor relay and circuit problem (LED flashes 19 times)

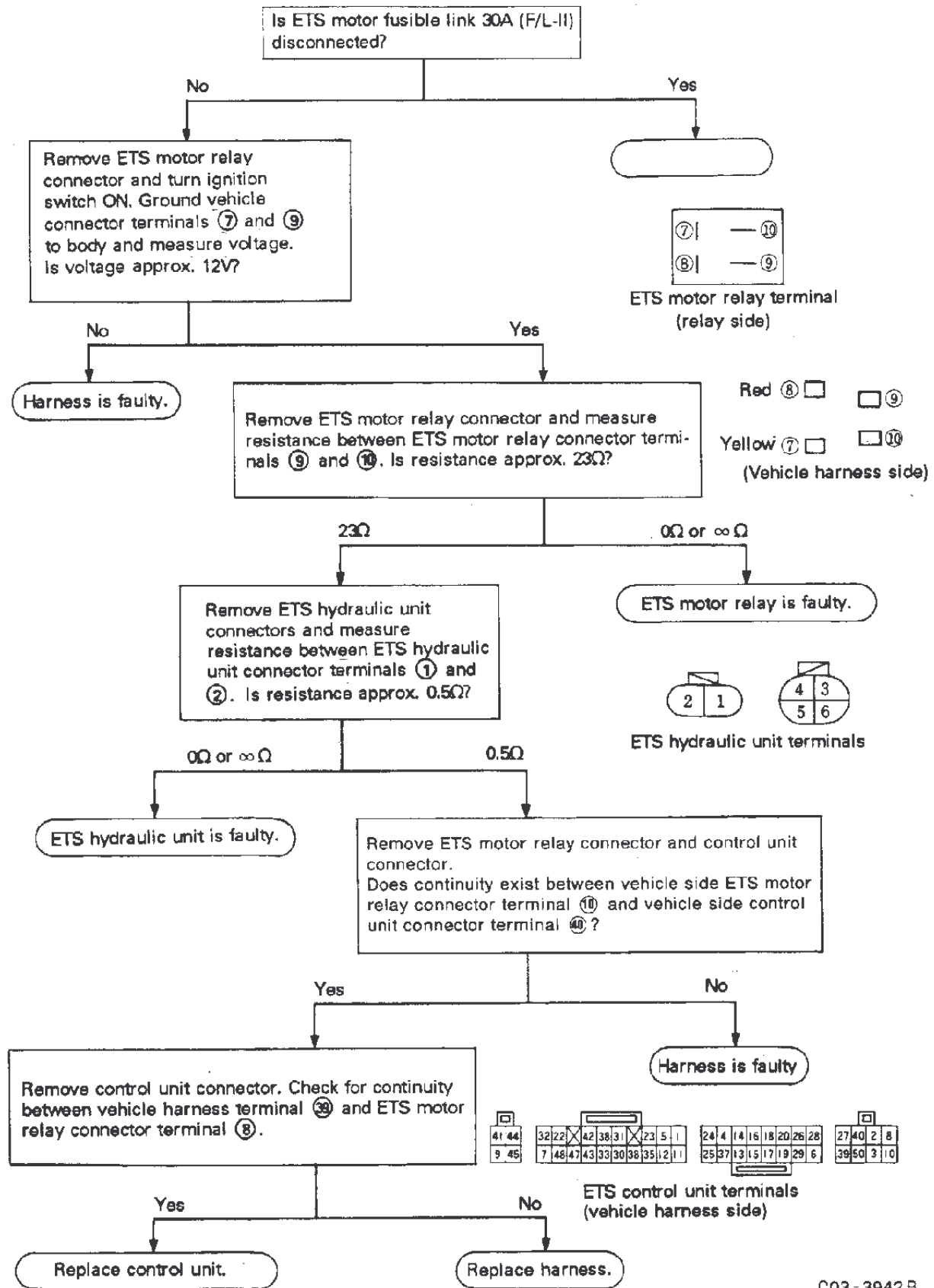

C03-3942B

C3 ELECTRICAL CONTROL TORQUE SPLIT 4WD SYSTEM (ATTESSA E-TS)

3. Troubleshooting (Cont'd)

N. ETS solenoid and circuit problems (LED flashes 20 times)

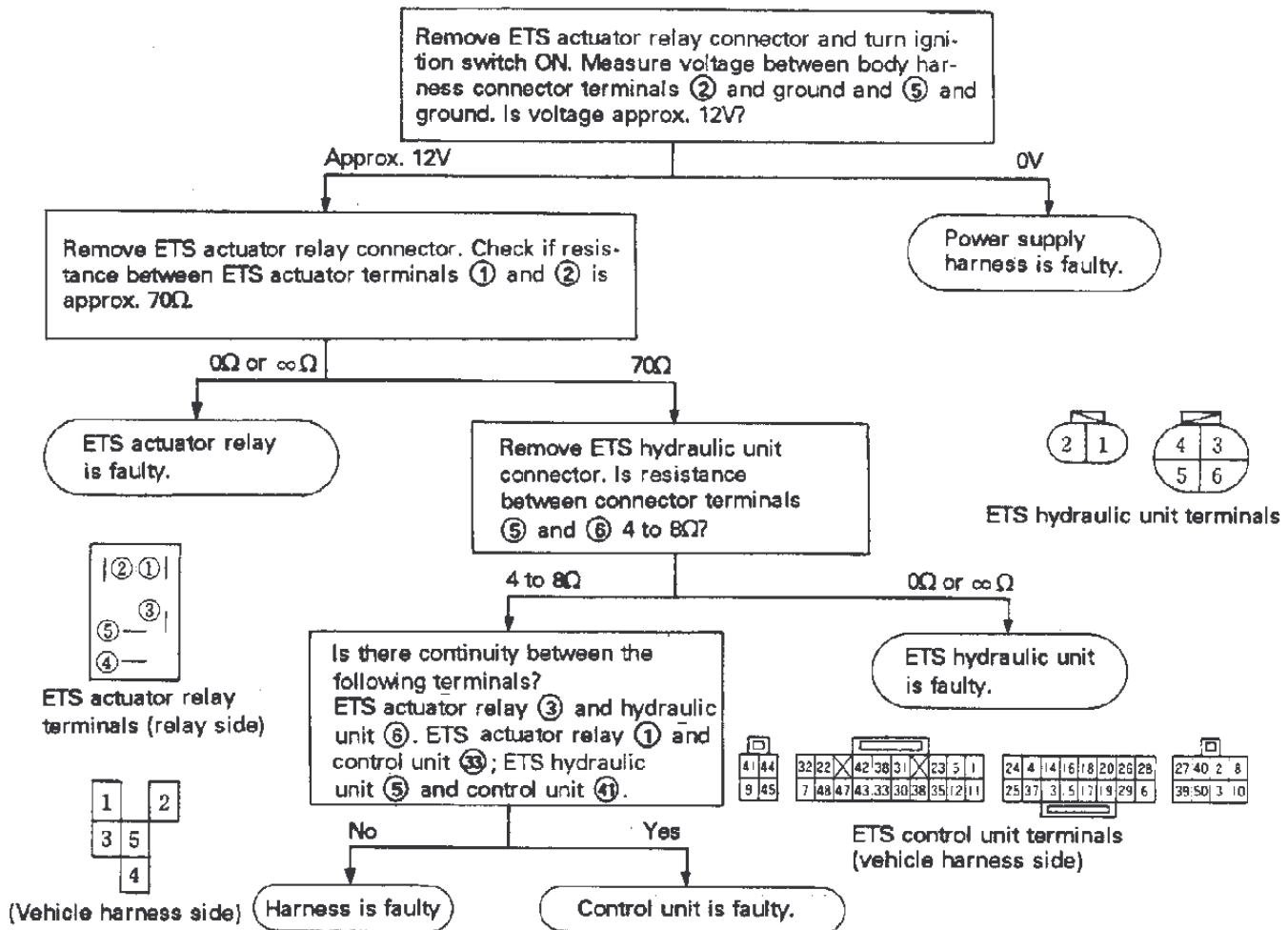

C03-3943 B

O. Throttle sensor and circuit problems (LED flashes 21 times)

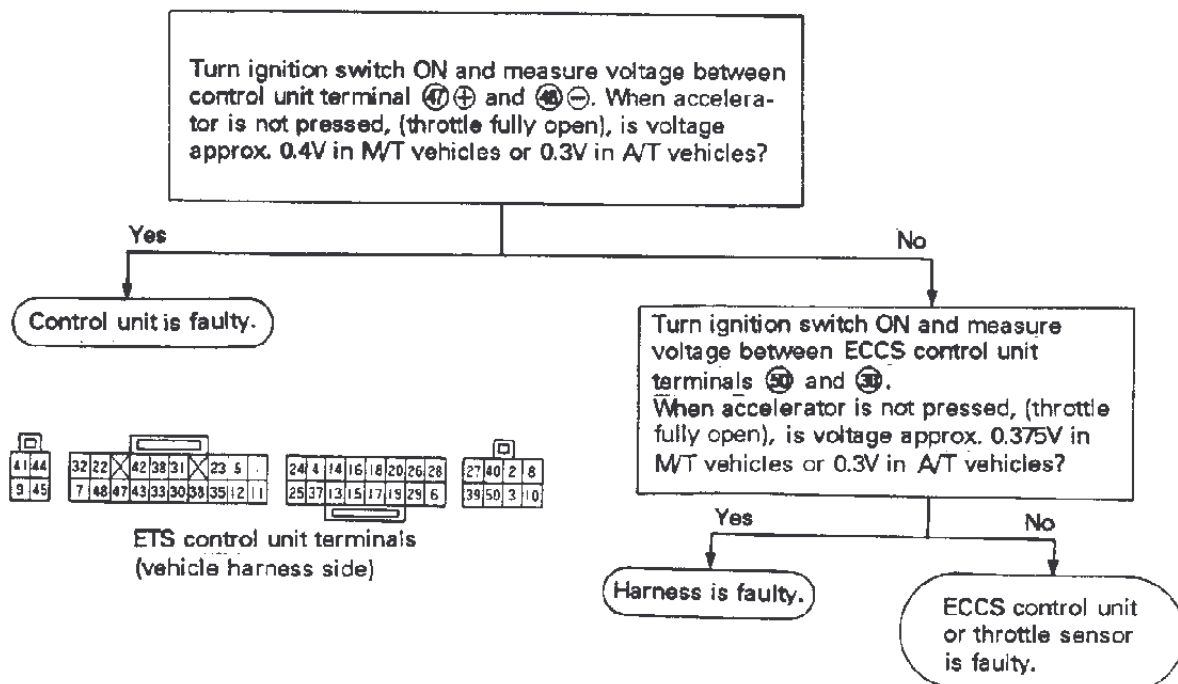

C03-3944 B

C3 ELECTRICAL CONTROL TORQUE SPLIT 4WD SYSTEM (ATTESSA E-TS)

3. Troubleshooting (Cont'd)

P. Oil level sensor and circuit (LED flashes 22 times)

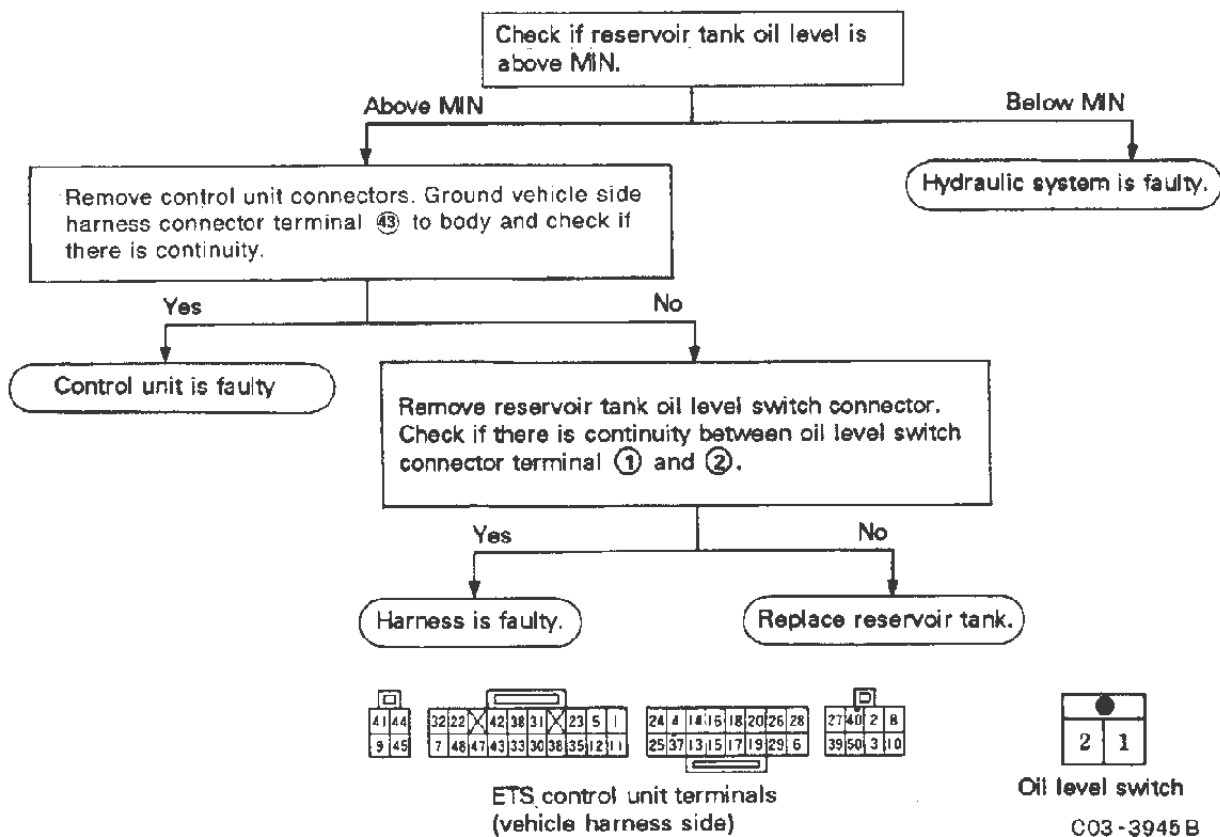

Q. ETS control unit and ground circuit (LED flashes 24 times)

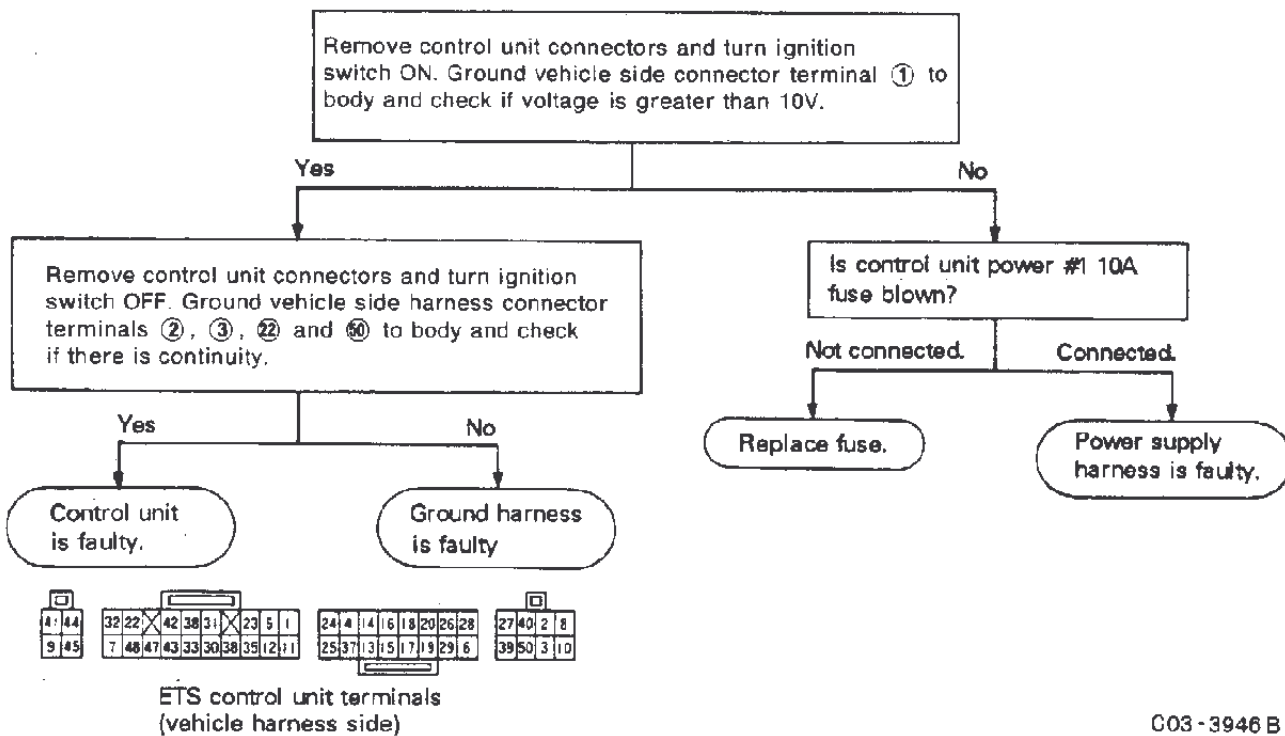

C3 ELECTRICAL CONTROL TORQUE SPLIT 4WD SYSTEM (ATTESSA E-TS)

3. Troubleshooting (Cont'd)

R. 4WD warning lamp flashes

If the 4WD warning lamp flashes every 2 sec while driving, this indicates that there is a large difference in tire diameter between front and rear wheels. Replace tires with standard size tires so all four tire dimensions are the same.

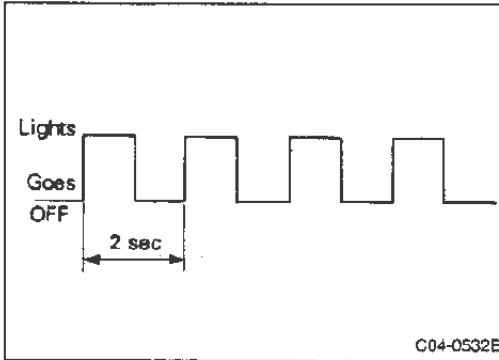

(4) Part inspection

① Speed sensor installation and inspection

- Check that all parts are installed securely. Tighten any loose parts to specified tightening torque.

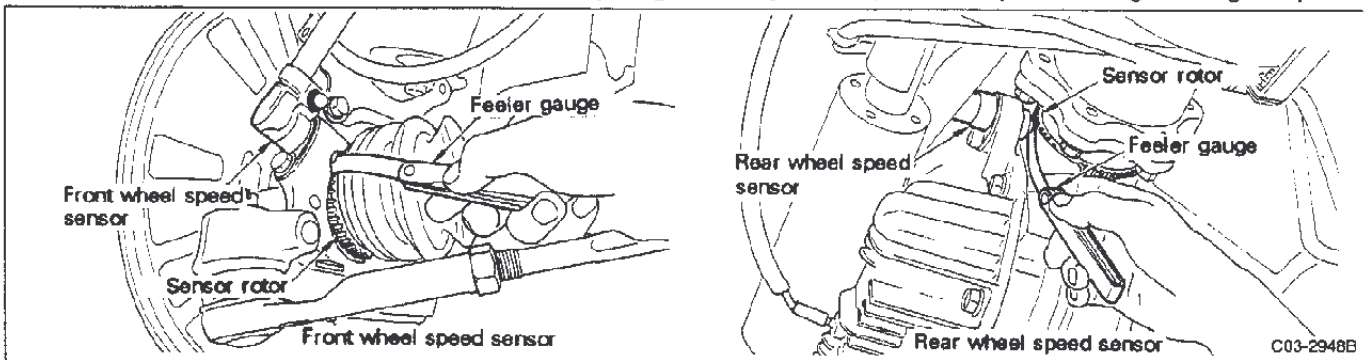

- Measure clearance between sensor and rotor as shown in figure. Check if clearance conforms to following values.

	Clearance standard value mm (in)
Front wheel speed sensor	0.27 - 0.75 (0.0106 - 0.0295)
Rear wheel speed sensor	0.6 - 0.93 (0.0236 - 0.0366)

- Make sure there are no cracks or damage in rotor gear.
- Replace sensor rotor if there is any problem.

CAUTION:

Replace rear side sensor rotor in matched set with companion flange.

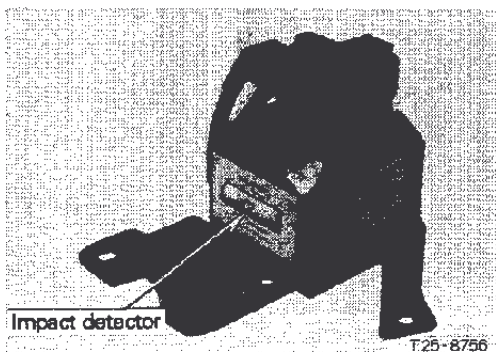

② G sensor inspection

- If G sensor has received an impact, the impact detector shown in the figure will turn red.
- If impact detector turns red, replace G sensor.

③ Air bleeding

- Refer to "4-4 HYDRAULIC UNIT AND RESERVOIR TANK" in "4. Removal and Installation, Assembly and Disassembly" for air bleeding procedures.

C3 ELECTRICAL CONTROL TORQUE SPLIT 4WD SYSTEM (ATTESSA E-TS)

3. Troubleshooting (Cont'd)

④ Part Inspection locations

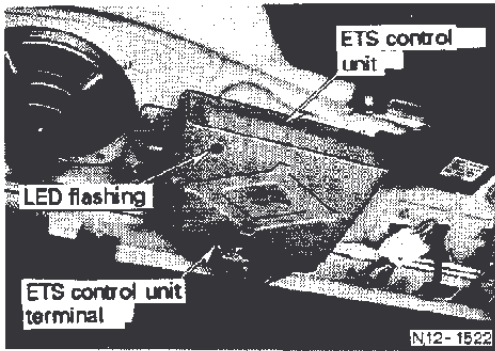

ETS control unit

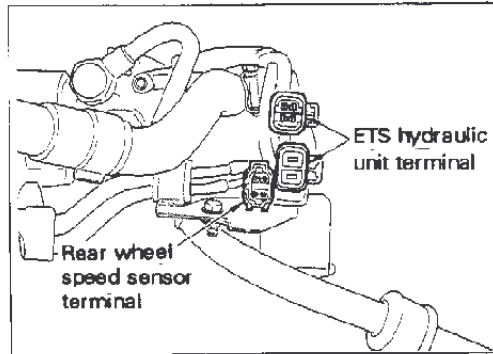

Hydraulic unit



Right and left front wheel speed sensors

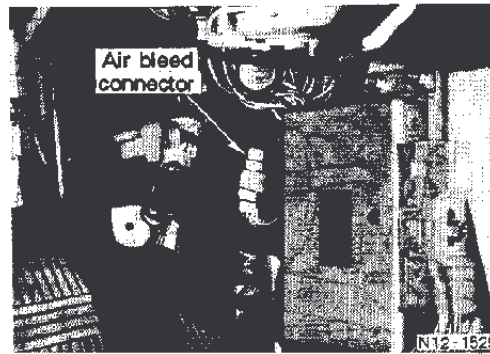

Air bleed connector



G sensor



ETS motor relay and ETS actuator relay

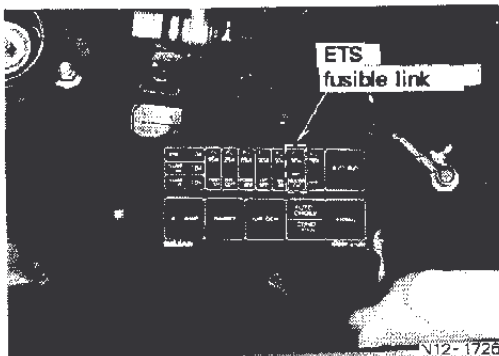

ETS fusible link



ETS fuse

C3 ELECTRICAL CONTROL TORQUE SPLIT 4WD SYSTEM (ATTESSA E-TS)

3. Troubleshooting (Cont'd)

3-3 HYDRAULIC SYSTEM TROUBLESHOOTING

(1) Preparation for troubleshooting

The hydraulic unit transmits hydraulic control during driving by commands from ETS control unit. The judgement if the ETS hydraulic unit operates normally is made when vehicle is stopped. Hydraulic pressure is generated by ON/OFF operation of the air bleeding switch (right side of passenger seat dashboard) used for air bleeding operation. The applied power can be checked by measuring the power.

CAUTION:

The hydraulic system inspection cannot be performed during driving.

(2) Inspection

Lift the vehicle and remove hydraulic hose and transfer unit from ETS hydraulic unit. Use special service tool (KV481 00410) for connector as shown in figure. Install power steering pressure gauge and open valve all the way.

Perform air bleeding of ETS hydraulic circuit.

Note 1: Refer to "4-4 HYDRAULIC UNIT AND RESERVOIR TANK" in "4. Removal and Installation, Assembly and Disassembly".

Turn ignition switch to ON. (Do not start engine.)

Move air bleed switch (ON ↔ OFF). Check that hydraulic pressure is 294 to 490 kPa (3 to 5 kg/cm², 43 to 71 psi) when engaged and 0 kPa (0 kg/cm², 0 psi) when not engaged.

Note 2: Do not engage air bleed switch for more than 10 seconds because heat is generated and fail-safe will operate when ETS motor is run continuously.

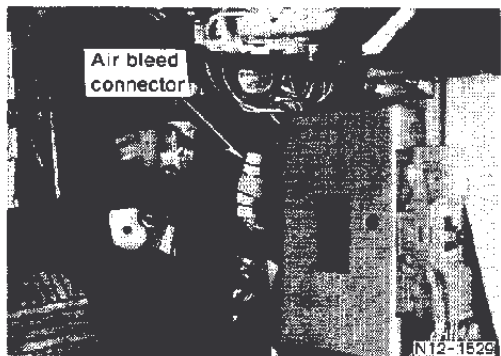
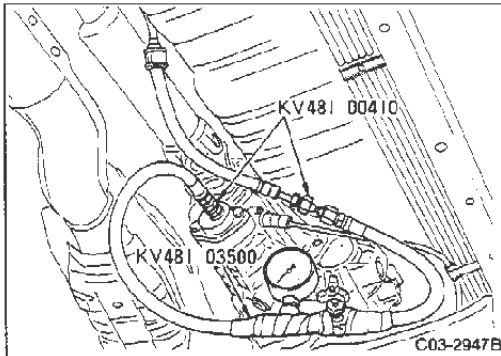

Normal ①

Abnormal

Remove power steering unit and connect ETS hose to transfer unit.

ETS hydraulic circuit air bleeding

End

Refer to "4-4 HYDRAULIC UNIT AND RESERVOIR TANK" in "4. Removal and Installation, Assembly and Disassembly".

Perform troubleshooting by self-diagnosis procedures and then check pressure again.

Abnormal

Normal

Replace ETS hydraulic unit.

To ①

C3 ELECTRICAL CONTROL TORQUE SPLIT 4WD SYSTEM (ATTESSA E-TS)

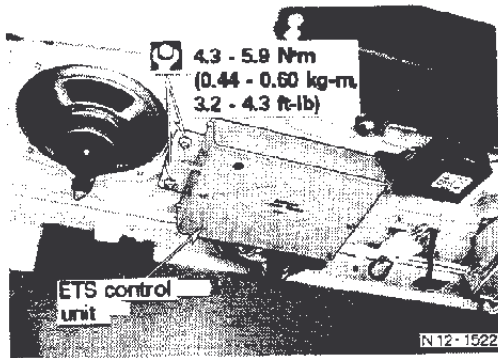

4. Removal and Installation, Assembly and Disassembly

4-1 ETS CONTROL UNIT

(1) ETS control unit removal and installation

- The ETS control unit is installed under the rear parcel shelf in the trunk.
- The body ground is connected to the top side of rear parcel shelf.

4-2 G SENSOR

(1) Installation precautions

- Be especially careful not to drop or hit G sensor since it is sensitive to impact. If the unit is subjected to impact do not use it if the impact detector turns red as shown in figure.

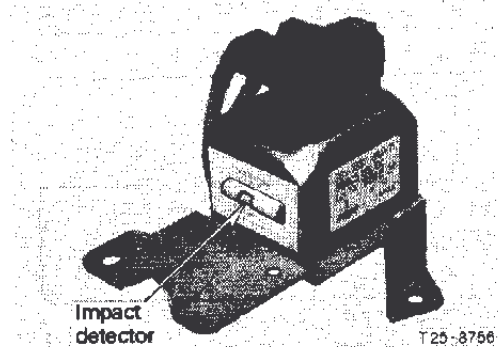

(2) G sensor removal and installation

- The G sensor is installed under sensor console.

CAUTION:

- (1) Observe precautions described above when removing and installing sensor.
- (2) The G sensor cannot be disabled.

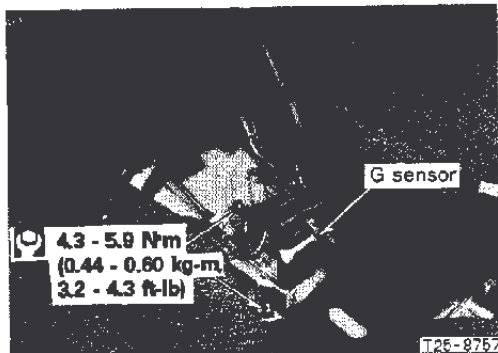

C3 ELECTRICAL CONTROL TORQUE SPLIT 4WD SYSTEM (ATTESSA E-TS)

4. Removal and Installation, Assembly and Disassembly (Cont'd)

4-3 SPEED SENSOR

(1) Front wheel speed sensor removal and installation

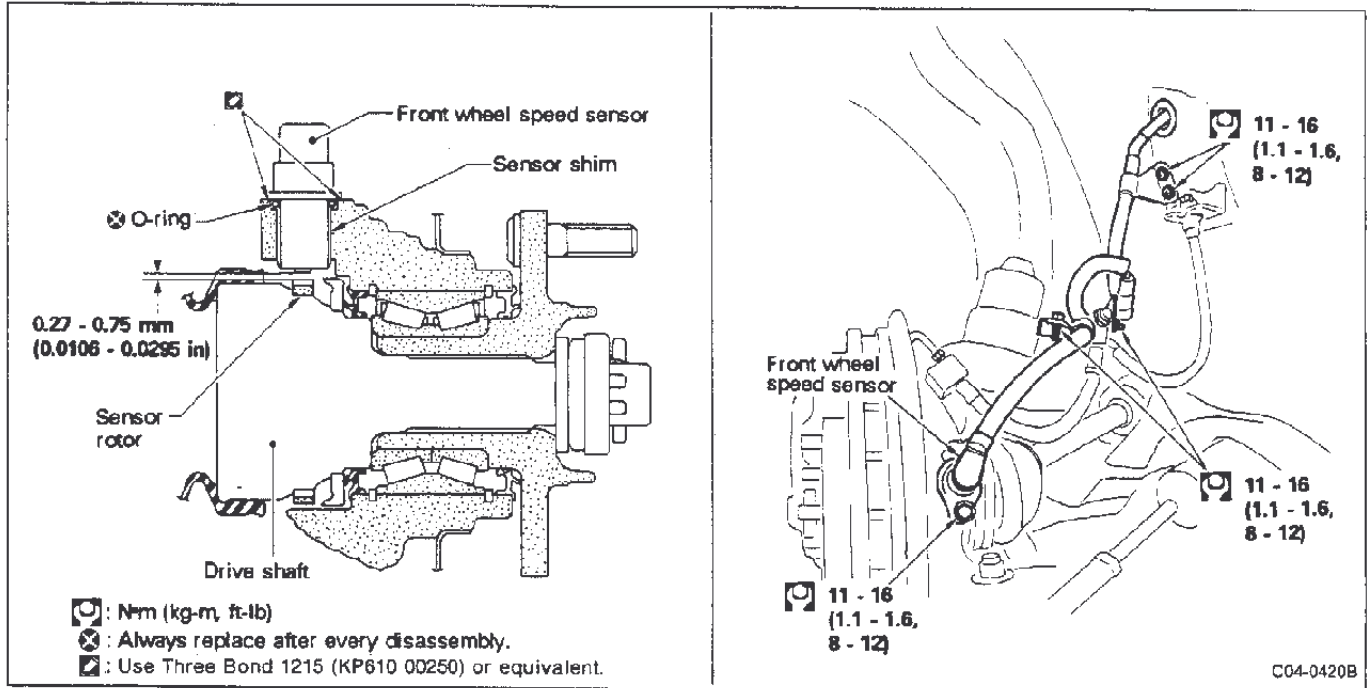

[Point 1] Front wheel sensor rotor removal and installation

CAUTION:

Because center rotor is connected to the drive shaft, remove drive shaft before removing or installing center rotor. Refer to C6 DRIVE SHAFT, 3-1 REMOVAL AND INSTALLATION.

Removal

- For steering gear assembly and disassembly, position attachment (special service tool) or 15-mm (0.59 in) thick support against center rotor and remove with dust shield as a single unit.

Installation

- Position drift (special service tool) against center rotor and press-fit bearing.

CAUTION:

Be careful not to damage rotor during removal and installation.

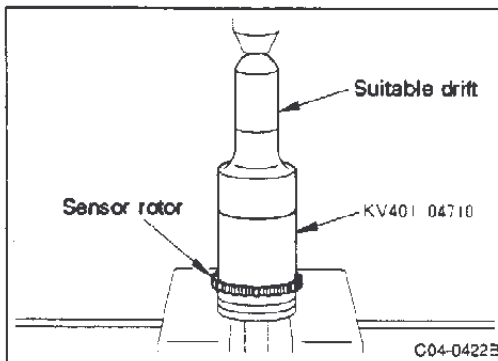
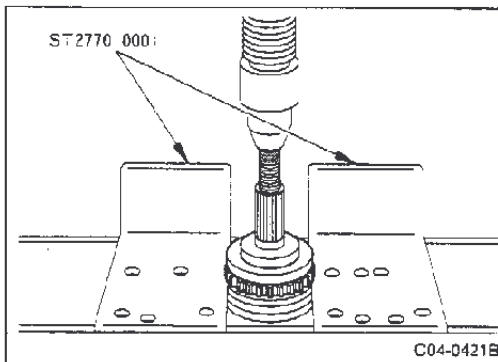

C3 ELECTRICAL CONTROL TORQUE SPLIT 4WD SYSTEM (ATTESSA E-TS)

4. Removal and Installation, Assembly and Disassembly (Cont'd)

- Set drift (special service tool) against dust shield as shown in figure and press-fit to install.

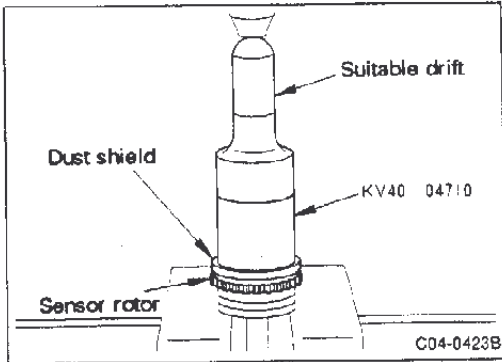

[Point 2] Front wheel speed sensor installation

- Install sensor shims in knuckle spindle.
- Install O-ring in front wheel speed sensor.
- Coat entire knuckle spindle mating surface with sealant (silicon bond 1215 [KP210 00200]). Install front wheel speed sensor and tighten to specified torque.

Front wheel speed sensor tightening torque:
 11 - 16 N·m (1.1 - 1.6 kg·m, 8 - 12 ft·lb)

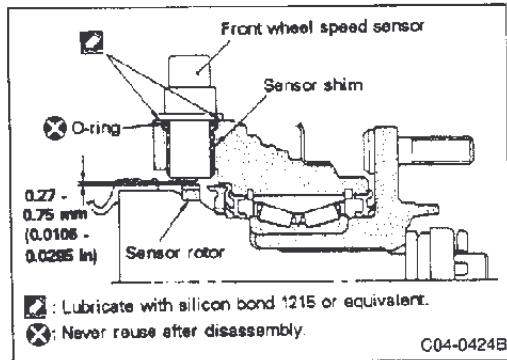

(2) Rear wheel speed sensor removal and installation

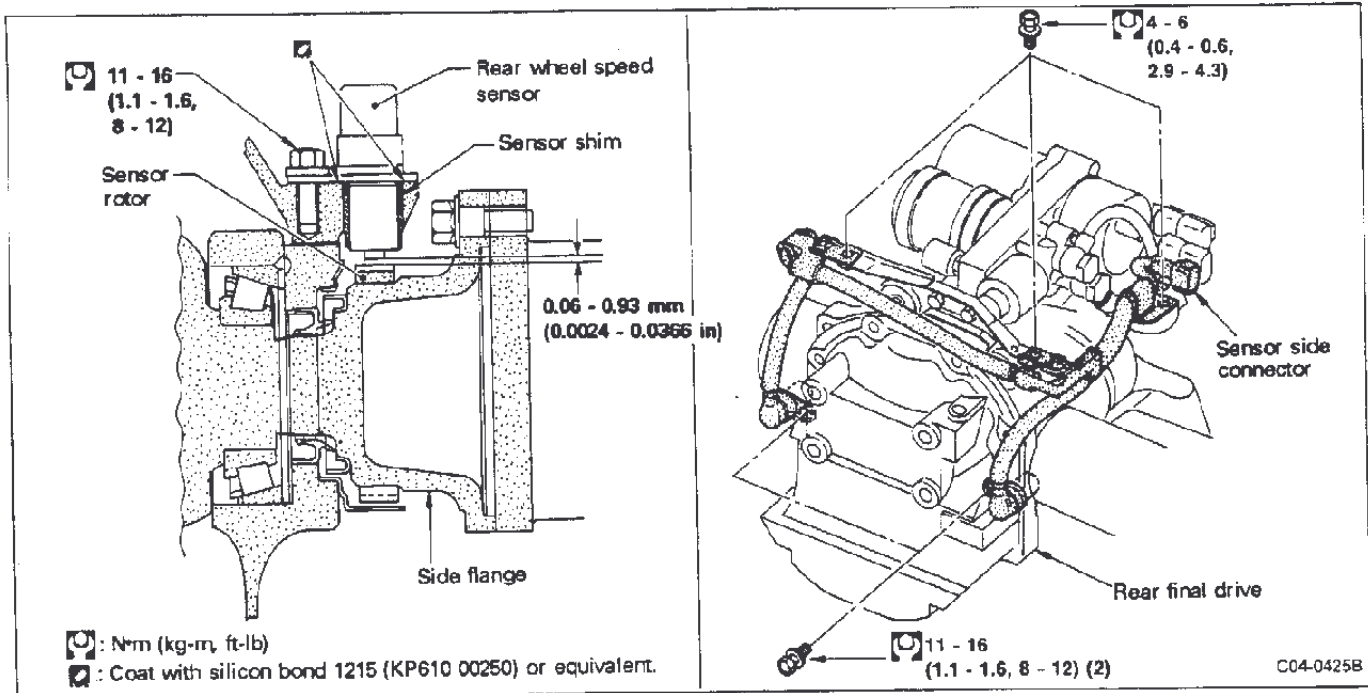

C3 ELECTRICAL CONTROL TORQUE SPLIT 4WD SYSTEM (ATTESSA E-TS)

4. Removal and Installation, Assembly and Disassembly (Cont'd)

[Point 1] Rear wheel sensor rotor removal and installation

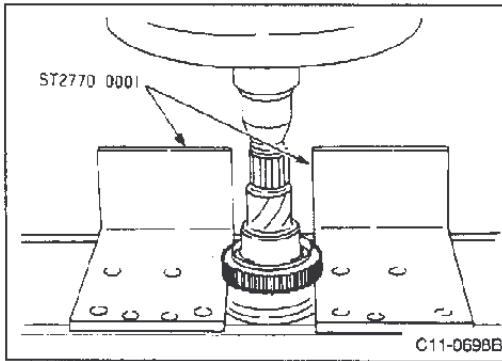

CAUTION:

Remove or install sensor rotor after removing side flange because it is installed in side flange. Refer to C6 DRIVE SHAFT, 3-1 REMOVAL AND INSTALLATION for removal and installation procedures.

Removal

- Position attachment (special service tool) for steering gear assembly and disassembly or 15-mm (0.59 in) thick support against sensor rotor and remove with dust shield as a single unit.

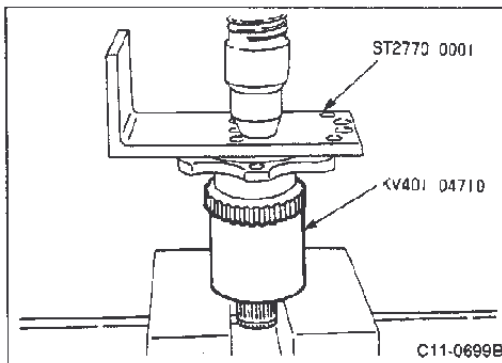

Installation

- Position drift (special service tool) on sensor rotor as shown in figure and press-fit rotor to install it.

[Point 2] Rear wheel speed sensor installation

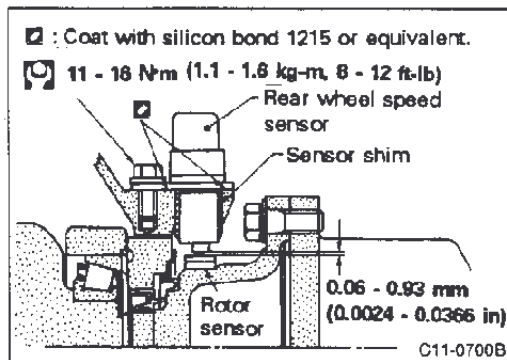

- Install sensor shim in differential case.
- Coat mating surfaces of differential case with sealant (silicon bond 1215 or equivalent). Install rear wheel speed sensor and tighten to specified torque.

C3 ELECTRICAL CONTROL TORQUE SPLIT 4WD SYSTEM (ATTESSA E-TS)

4. Removal and Installation, Assembly and Disassembly (Cont'd)

[Point 2] Hydraulic unit assembly and disassembly

- Remove bracket and rear wheel speed sensor and pipe from hydraulic unit as shown in figure.

CAUTION:

The hydraulic unit cannot be taken apart.

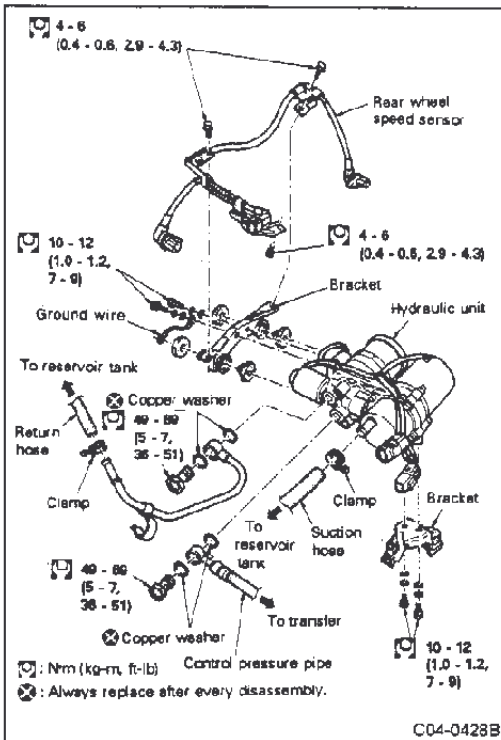

[Point 3] Air bleeding

Precautions

- Only use genuine Nissan special power steering fluid.
- Make sure all piping connections are tightened securely.
- The reservoir tank is located inside trunk. To avoid oil spill during operation, remove carpet and spread rags in trunk.
- Pay attention to the reservoir tank oil level during operation. Be careful not to allow air to enter from the suction side and replenish as necessary.

Air bleeding procedures

- ① Fill the reservoir tank with oil approx. 30 mm (1.18 in) above MAX line.

CAUTION:

Be careful not to spill any oil inside the trunk.

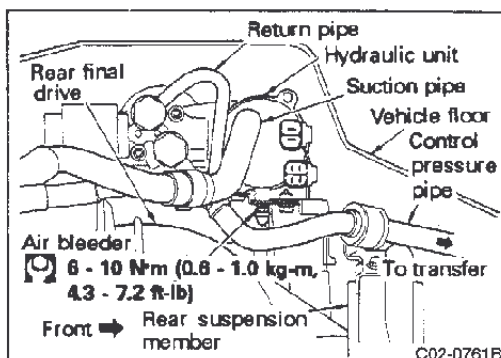
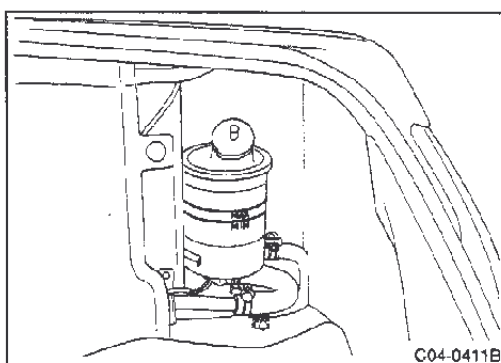

- ② Open the air bleeder in hydraulic unit (installed above rear differential) and remove all air in suction pipe. When air bleeder stops discharging air, close air bleeder and tighten to specified torque.

Reference: If the air bleeder is opened, oil flows into the suction pipe due to the gravity.

CAUTION:

When oil remains inside reservoir tank, it is not necessary to perform the operation described above.

C3 ELECTRICAL CONTROL TORQUE SPLIT 4WD SYSTEM (ATTESSA E-TS)

4. Removal and Installation, Assembly and Disassembly (Cont'd)

- ③ Turn ignition switch ON.
- ④ Remove the air bleeder connector (lower dash side) shown in the figure.

Reference: If the connection line is disconnected, the air bleed mode is set, pump motor operates and fixed hydraulic pressure is supplied to the transfer actuator.

- ⑤ Open and close the air bleeder on actuator side of transfer quickly, 1 second each time. To bleed air from system, repeat operation until no more air is discharged. When air bleeding is completed, tighten air bleeder to specified torque.

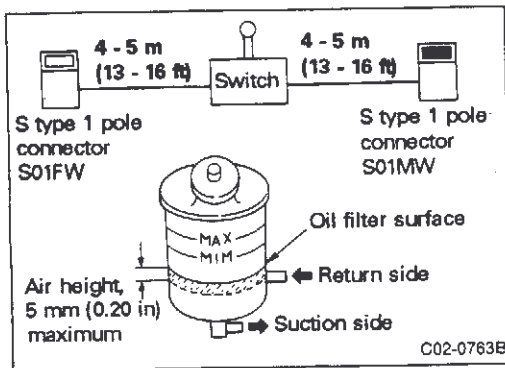
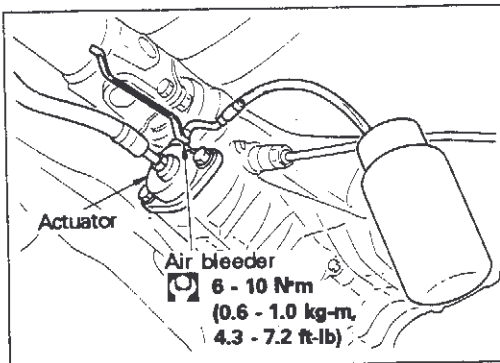
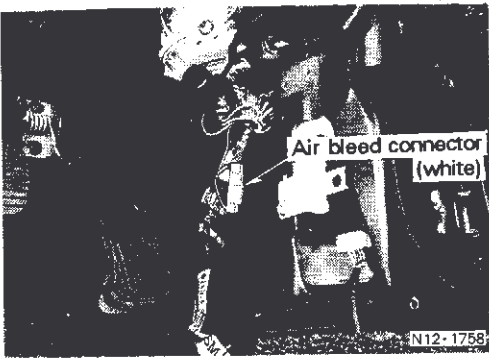

- ⑥ Connect air bleeder connector intermittently, turn pump ON and OFF and bleed air from reservoir tank return side.

CAUTION:

After air bleeding is completed, a maximum air level height of 5 mm (0.20 in) is allowable.

Reference: The retaining clip for the connector may be damaged or proper connection may not be possible, make an air bleed switch as shown in figure to perform operation.

- ⑦ Connect air bleeder connector. Fill or drain reservoir tank so oil volume is at MAX line.

CAUTION:

Turn ignition switch ON before adjusting oil level.

- ⑧ Turn ignition switch OFF to complete air bleed operation.

C3 ELECTRICAL CONTROL TORQUE SPLIT 4WD SYSTEM (ATTESSA E-TS)

4. Removal and Installation, Assembly and Disassembly (Cont'd)

4-5 TRANSFER

(1) Removal and installation

The transfer unit and transmission should be removed and installed as a single unit. Refer to C2 MANUAL TRANSMISSION, 3-1 REMOVAL AND INSTALLATION.

(2) Disassembly from transmission

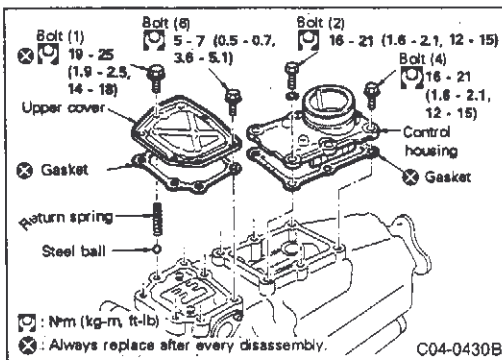
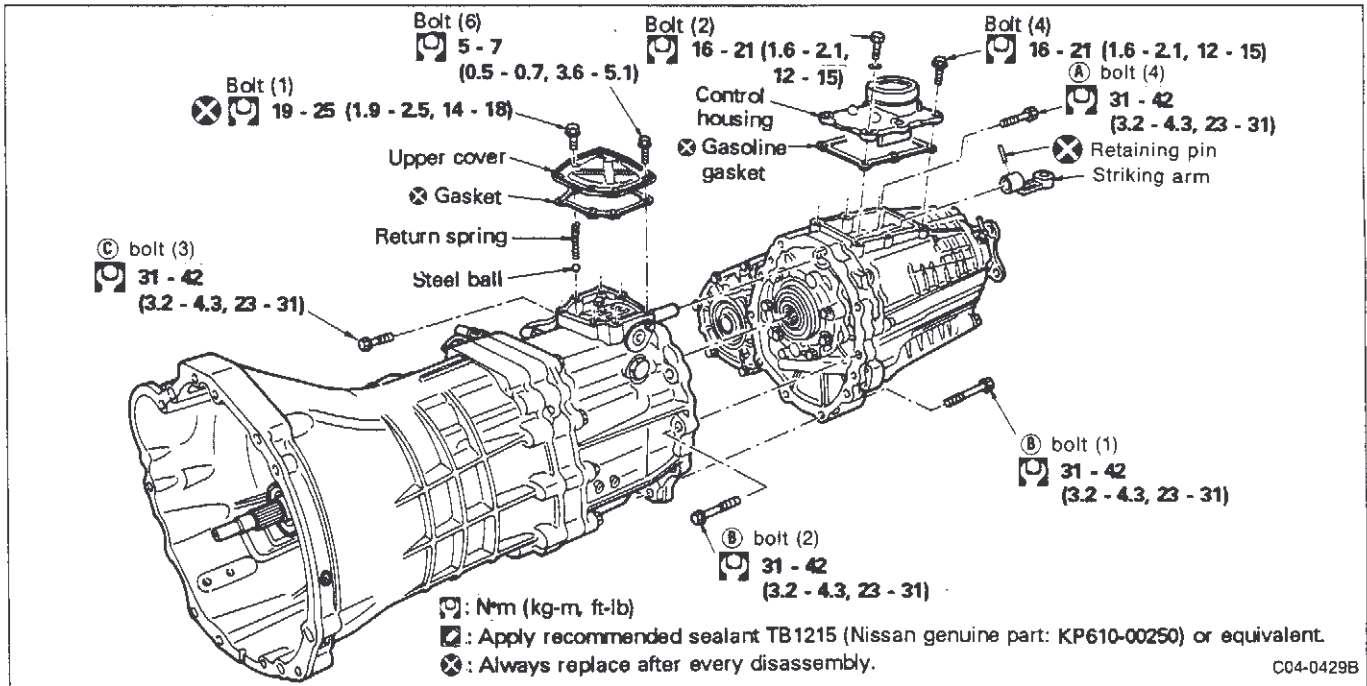

[Point 1] Transfer disassembly

Removal

- Remove upper cover from transmission. Remove return spring and steel ball from OD case.
- Remove control housing and gasket from transfer unit.

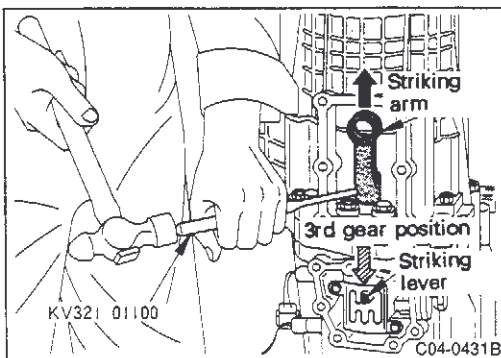

- Pull striking arm in direction of arrow mark (3rd gear position) shown in the figure. Use pin punch (special service tool) to remove retaining pin from striking arm by tapping striking arm until it can be removed.

CAUTION:

If retaining pin is tapped out completely, the retaining pin will fall in the transfer unit.

C3 ELECTRICAL CONTROL TORQUE SPLIT 4WD SYSTEM (ATTESSA E-TS)

4. Removal and Installation, Assembly and Disassembly (Cont'd)

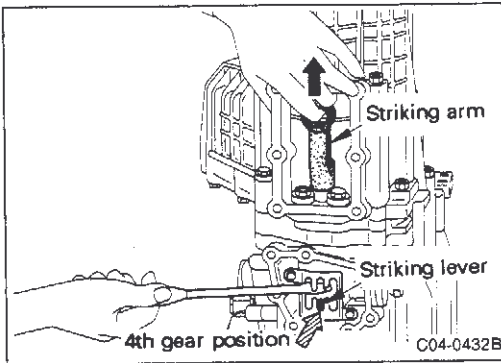

- Insert a screwdriver in 4th gear position and press striking lever in direction of arrow. When lever is secured, remove striking arm.

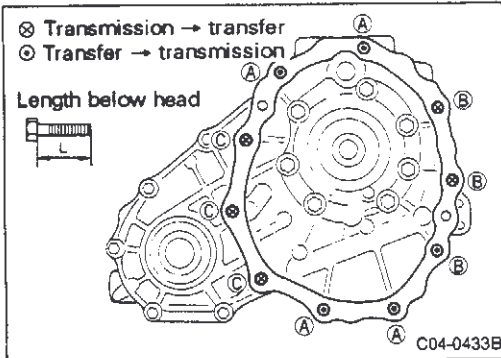

- There are three types of bolts in transfer unit. Remove bolts in sequence indicated in figure. If necessary, tap bolts with rubber hammer to loosen them.

Bolt	Description	Tightening torque N·m (kg·m, ft·lb)	Length below head mm (in)
A		31 - 42 (3.2 - 4.3, 23 - 31)	75 (2.95)
B			45 (1.77)
C			40 (1.57)

CAUTION:

- (1) The transmission surface shown in the figure is viewed from transmission side.
- (2) Do not loosen the M8 bolts at this point because they hold the transmission case together. (The transfer unit bolts are all M10 bolts.)
- (3) Do not scratch or damage front case or transmission mating surfaces.

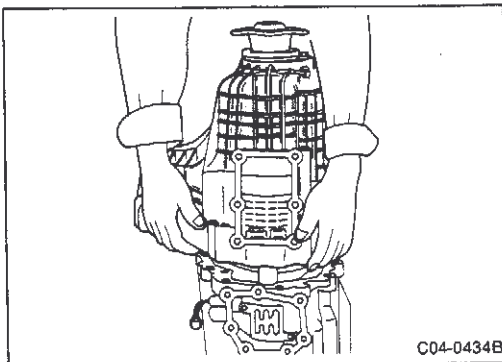

- Remove transfer unit in upright position and do not tilt.

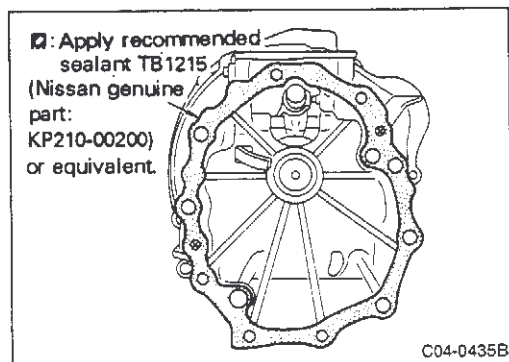

[Point 2] Transfer unit installation

- Apply recommended sealant TB1215 (Nissan genuine part: KP210-00200) or equivalent to mating surface and transmission.

CAUTION:

- (1) OD case must be coated with sealant.
- (2) Coat striking lever end with Nissan MP special grease before installation.

C3 ELECTRICAL CONTROL TORQUE SPLIT 4WD SYSTEM (ATTESSA E-TS)

4. Removal and Installation, Assembly and Disassembly (Cont'd)

- Rotate companion flange in both directions to align transmission main drive shaft and transfer unit mainshaft serration and install transfer unit.

CAUTION:

Be careful not to damage oil seal with the transmission striking rod.

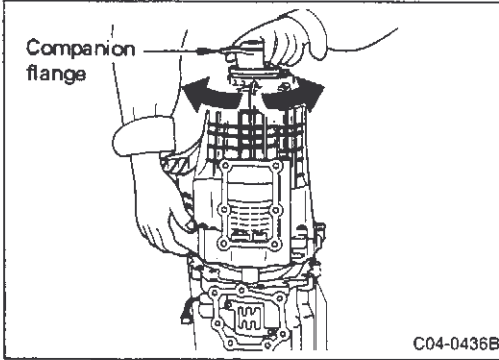

- There are three types of bolts in transfer unit. Remove bolts in sequence indicated in figure.

Bolt	Description	Tightening torque N·m (kg·m, ft·lb)	Length below head mm (in)
A		31 - 42 (3.2 - 4.3, 23 - 31)	75 (2.95)
B			45 (1.77)
C			40 (1.57)

CAUTION:

The figure shows the transfer installation surface viewed from transmission side.

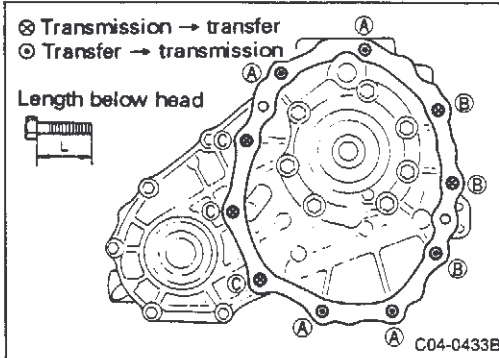

- Press in striking rod, set 4th gear position and install striking arm in striking rod.
- Use screwdriver and set striking lever in 3rd gear and align striking arm with striking rod retaining pin installation hole position.

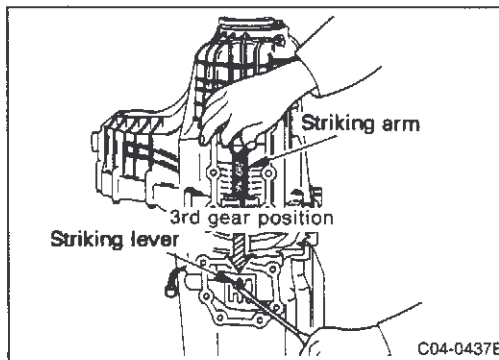

- Use screwdriver and set striking lever in 5th gear position.
- Use pin punch (special service tool) to install retaining pin in striking arm.

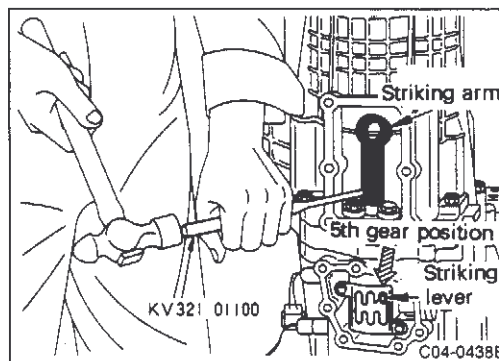

C3 ELECTRICAL CONTROL TORQUE SPLIT 4WD SYSTEM (ATTESSA E-TS)

4. Removal and Installation, Assembly and Disassembly (Cont'd)

- Install spring and check ball in transmission. Install upper cover and gasket.

CAUTION:

Always replace return spring installation bolt after every disassembly.

- Install control housing and gasket in transfer unit.

CAUTION:

Control housing position is set by **Ⓓ** bolts (2).

Bolt	Description	Tightening torque N·m (kg-m, ft-lb)	Length below head mm (in)
A		5 - 7 (0.5 - 0.7, 3.6 - 5.1)	16 (0.63)
B		19 - 25 (1.9 - 2.5, 14 - 18)	17 (0.67)
C		16 - 21 (1.6 - 2.1, 12 - 15)	25 (0.98)
D			30 (1.18)

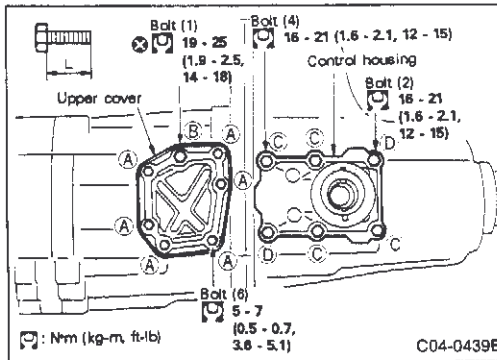
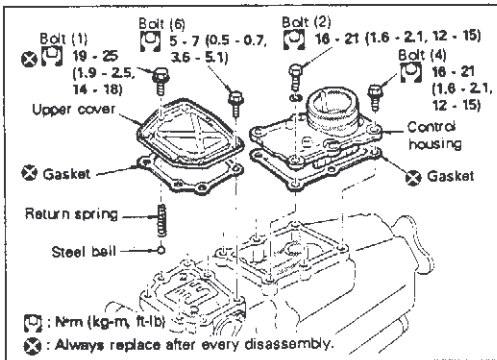

(3) Transfer removal and installation, assembly and disassembly

Assembly and disassembly precautions

- Operations should be performed in a clean environment and preferably in a dust-free room.
- Before starting, use steam or white gasoline to remove any debris or foreign matter from outside of unit to prevent it from entering unit during assembly and disassembly.
(Do not allow steam to enter the transfer unit. Do not wash rubber surfaces with gasoline.)
- Visually inspect all assembly parts for damage, deformation, abnormal wear and replace faulty parts as necessary.
- Always replace O-rings and oil seals after disassembly.
- Use paper rags to clean dirt off internal mechanisms.
- Use a bare hands or vinyl gloves in assembly or disassembly operations.
- Do not allow lint or cloth fibers from rags or gloves to contact the parts.
- Always follow the specified tightening torque. Coat all new parts with Nissan multi-fluid D or Vaseline.
- Coat oil pump, front case and rear case mating surfaces with sealant fluid 518 (part number C1335 31X25).

C3 ELECTRICAL CONTROL TORQUE SPLIT 4WD SYSTEM (ATTESSA E-TS)

4. Removal and Installation, Assembly and Disassembly (Cont'd)

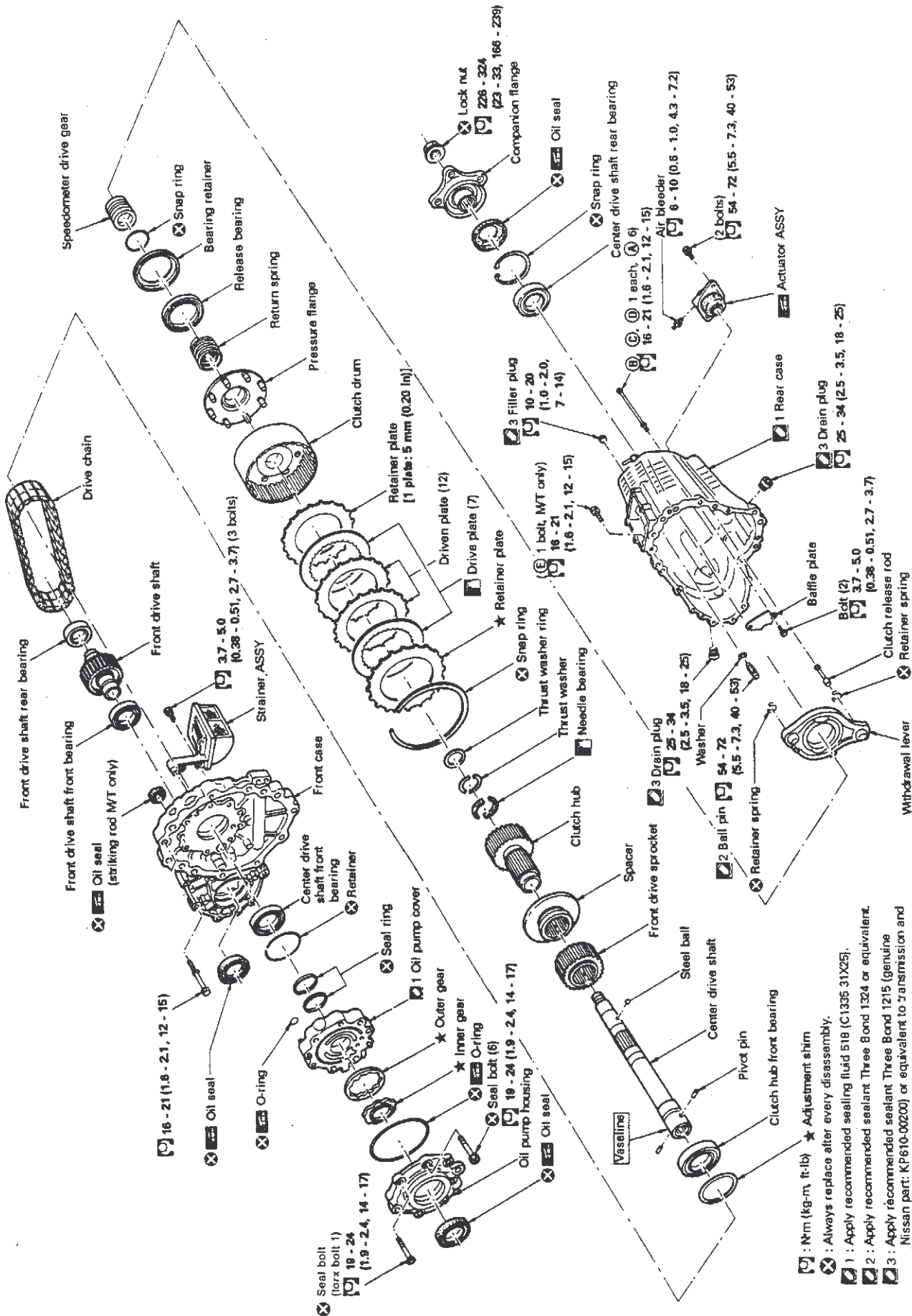

C3 ELECTRICAL CONTROL TORQUE SPLIT 4WD SYSTEM (ATTESSA E-TS)

4. Removal and Installation, Assembly and Disassembly (Cont'd)

① Removal

Oil pump removal

- Remove the seven bolts (1 torx bolt).

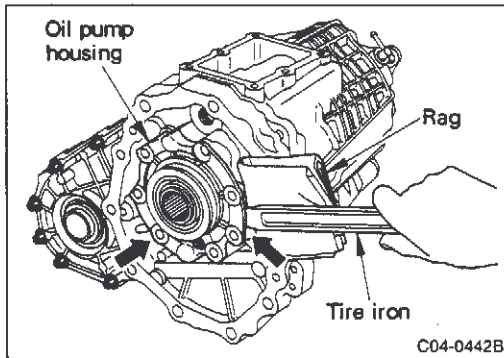
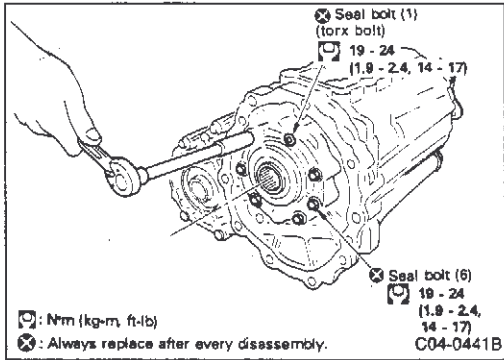

- Use a tire iron or large screwdriver and pry in direction of arrow to remove the housing.

CAUTION:

Wrap rags around tire iron to prevent scratching front of case.

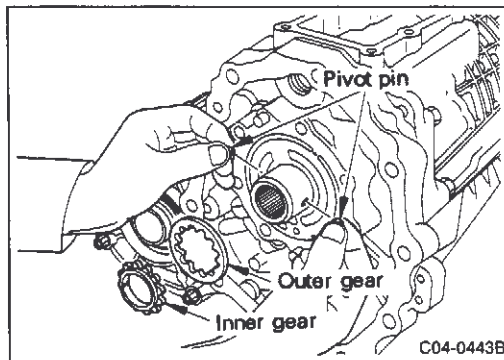

- Remove inner and outer gear and detach pivot pin from mainshaft.

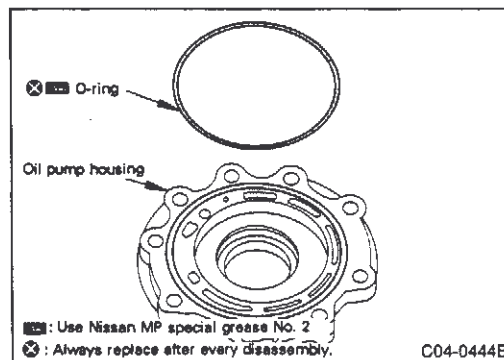

- Remove O-ring from housing.

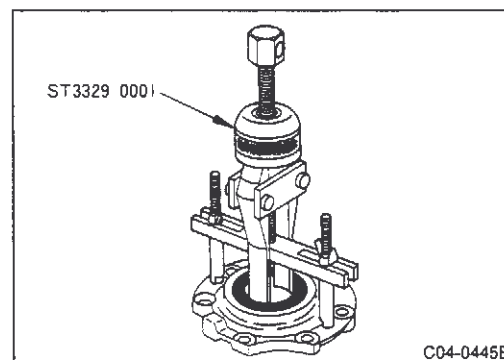

- Use oil seal puller (special service tool) as shown in figure and remove oil seal from housing.

C3 ELECTRICAL CONTROL TORQUE SPLIT 4WD SYSTEM (ATTESSA E-TS)

4. Removal and Installation, Assembly and Disassembly (Cont'd)

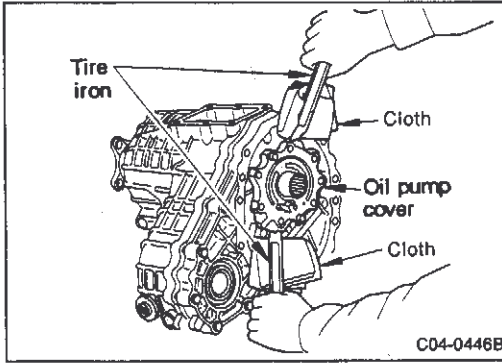

- Wrap cloth around tire irons and pry cover as shown in figure to remove cover.

CAUTION:

Wrap cloth around tire irons to prevent scratching front case.

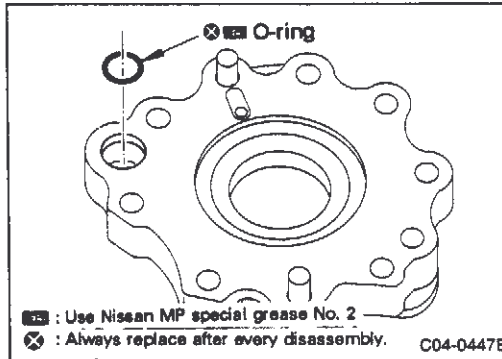

- Remove O-ring from strainer in cover.

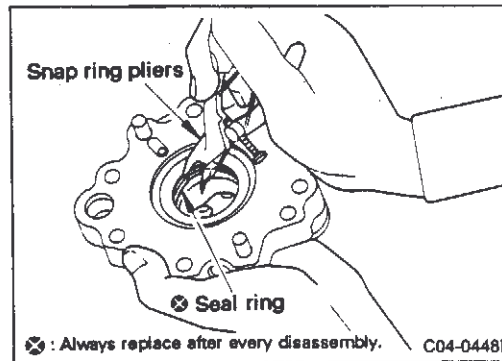

- Use small snap ring pliers to remove seal ring from cover.

CAUTION:

- (1) Do not scratch cover when removing ring.
- (2) Seal ring must be replaced after every disassembly.

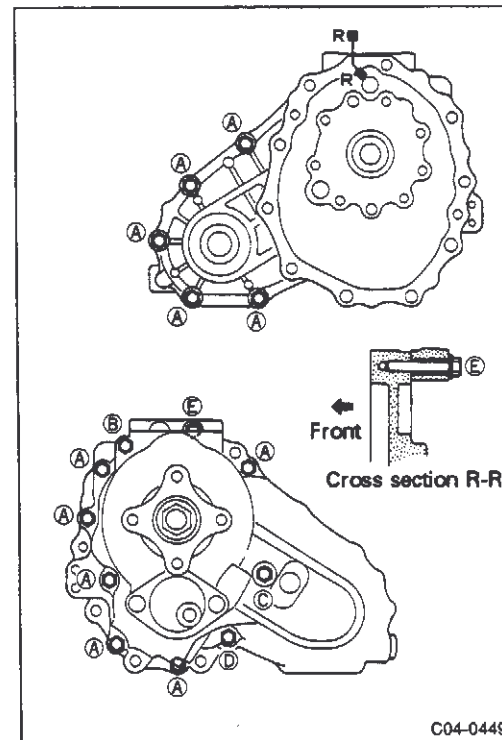

Front case removal

- Remove bolts from positions indicated in figure.

Bolt	Description	Tightening torque N·m (kg-m, ft-lb)	Length from head mm (in)
A (11 bolts)		16 - 21 (1.6 - 2.1, 12 - 15)	45 (1.77)
B (1 bolt)			165 (6.50)
C (1 bolt)			120 (4.72)
D (1 bolt)			100 (3.94)
E (1 bolt)			45 (1.77)

C3 ELECTRICAL CONTROL TORQUE SPLIT 4WD SYSTEM (ATTESSA E-TS)

4. Removal and Installation, Assembly and Disassembly (Cont'd)

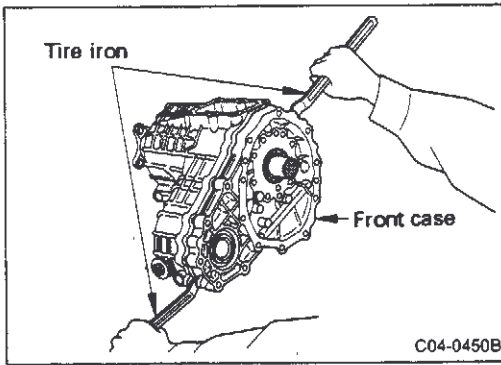

- Use a tire iron and remove front case as shown in figure.

CAUTION:

Be careful not to scratch front and rear surface of case.

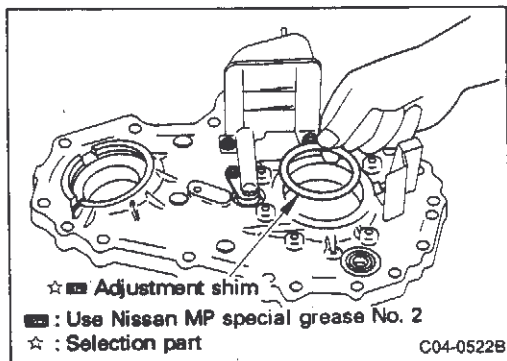

- Remove adjustment shim from front case.

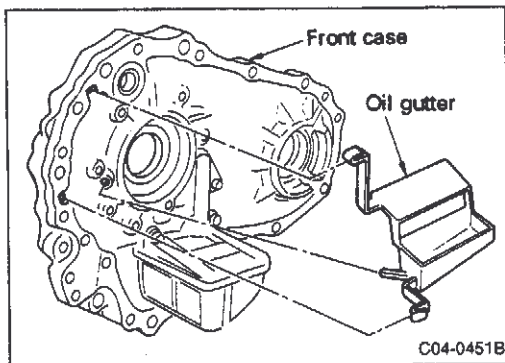

Oil gutter removal

- Remove oil gutter from front case.

CAUTION:

Be careful not to damage pawls.

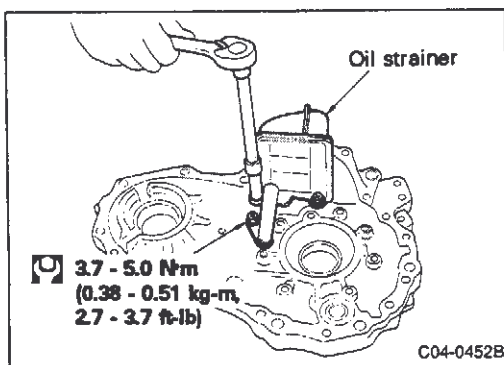

Oil strainer removal

- Remove three bolts and detach oil strainer.

CAUTION:

Do not damage screen.

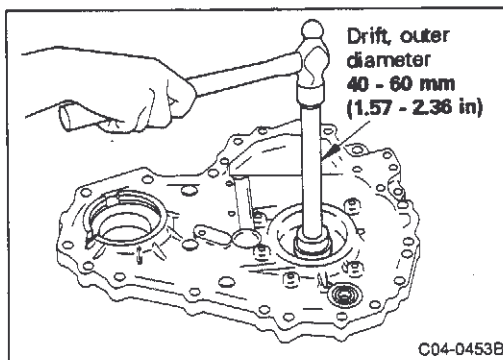

Center drive shaft front bearing removal

- Use drift with outer diameter 40 to 60 mm (1.57 to 2.36 in) to tap out front bearing from center drive shaft.

C3 ELECTRICAL CONTROL TORQUE SPLIT 4WD SYSTEM (ATTESSA E-TS)

4. Removal and Installation, Assembly and Disassembly (Cont'd)

Front drive shaft and drive chain removal

- Hold front drive shaft as shown in figure, and tap rear case with wooden hammer and remove chain and drive shaft together.

CAUTION:

Do not hit chain with wooden hammer. This may damage drive chain.

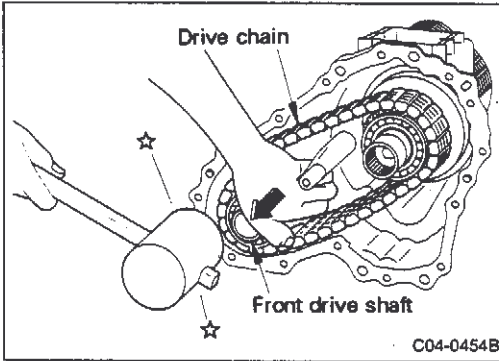

Front drive sprocket and clutch hub front bearing removal

- Position suitable drift on center drive shaft. Use a puller and remove clutch hub front bearing together with front drive sprocket.

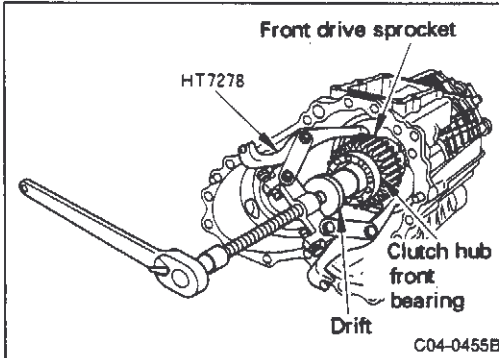

Spacer

- Position suitable drift on center drive shaft and use puller to remove spacer.

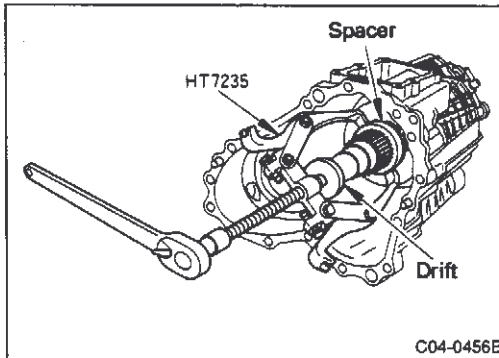

Clutch plate removal

- Use screwdriver and remove snap ring as shown in figure.

CAUTION:

Replace snap ring after every disassembly.

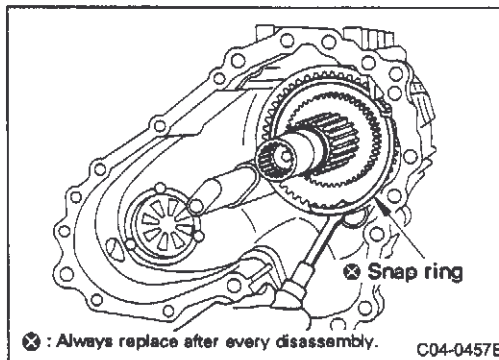

- Raise rear case as shown in figure and remove plate from clutch drum.

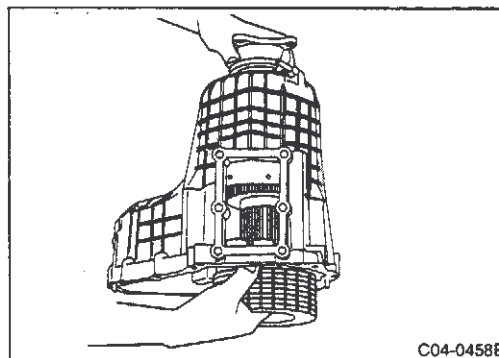

C3 ELECTRICAL CONTROL TORQUE SPLIT 4WD SYSTEM (ATTESSA E-TS)

4. Removal and Installation, Assembly and Disassembly (Cont'd)

Center drive shaft removal

- Place flange wrench on companion flange and remove lock nut.

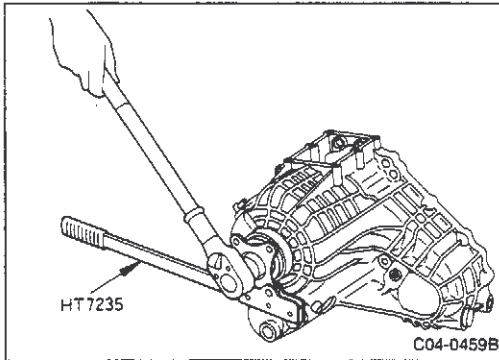

- Position suitable drift on center drive shaft and use puller to remove companion flange.

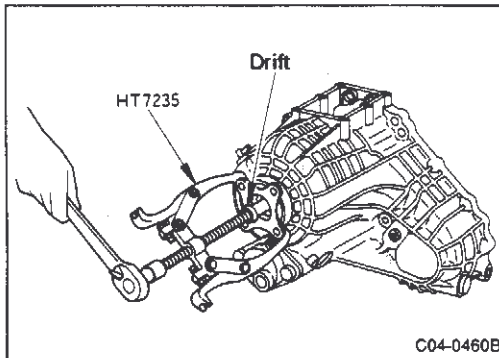

- Use wooden hammer to tap center drive shaft and remove unit.

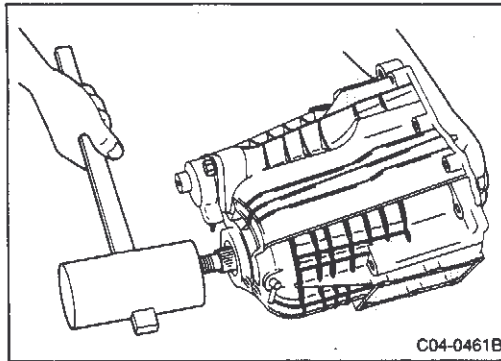

Withdrawal lever removal

- Remove withdrawal lever from ball pin in rear case and detach it by hand.

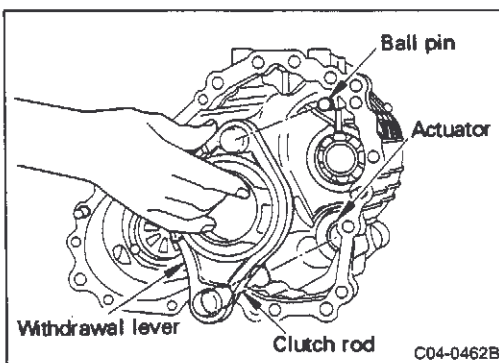

- Remove clutch release rod from withdrawal lever.

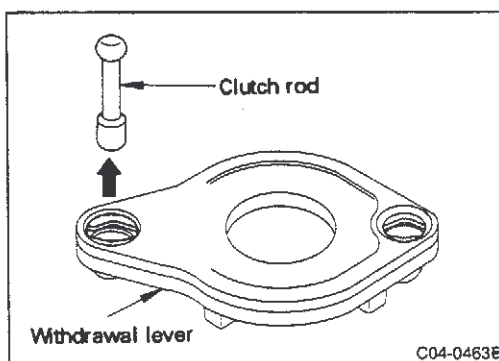

C3 ELECTRICAL CONTROL TORQUE SPLIT 4WD SYSTEM (ATTESSA E-TS)

4. Removal and Installation, Assembly and Disassembly (Cont'd)

- Use snap ring pliers to remove retainer spring.

CAUTION:

Replace retainer spring after every disassembly.

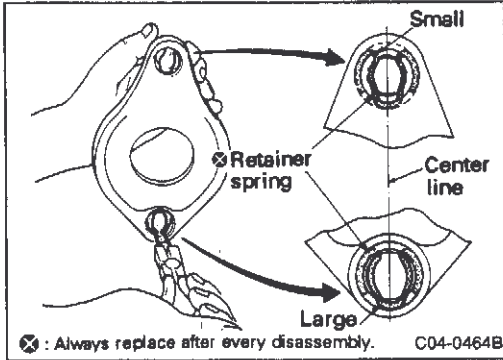

Baffle plate removal

- Remove two bolts and detach baffle plate.

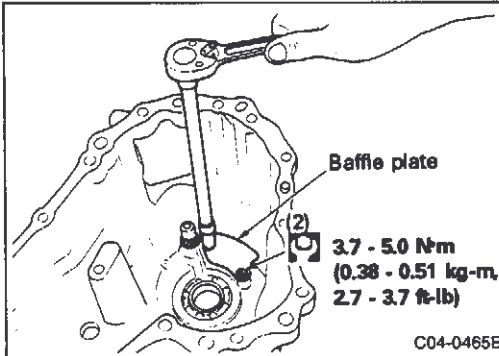

Ball pin removal

- Use deep socket wrench with two surface 17 mm (0.67 in) as shown in figure to remove ball pin.

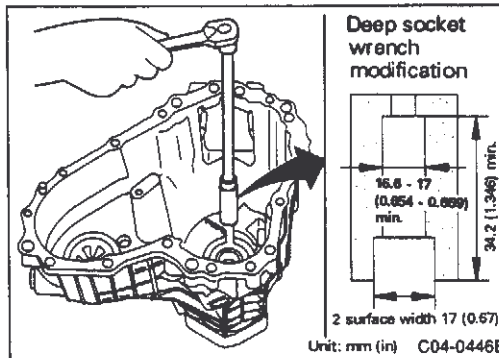

Actuator removal

- Remove the two bolts and detach bracket.

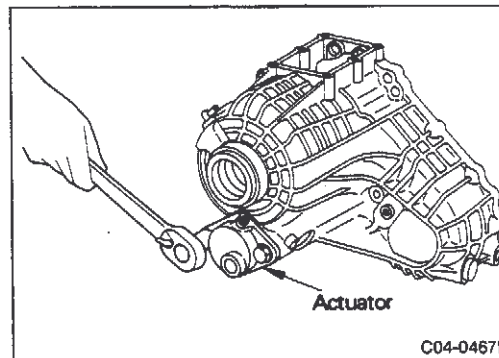

- Turn actuator to position shown in the figure and tap with wooden hammer to remove.

CAUTION:

Be careful not to scratch actuator boot.

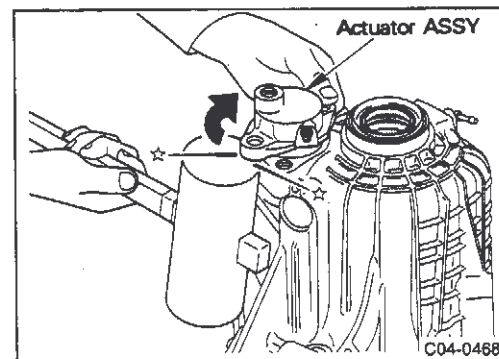

C3 ELECTRICAL CONTROL TORQUE SPLIT 4WD SYSTEM (ATTESSA E-TS)

4. Removal and Installation, Assembly and Disassembly (Cont'd)

Companion flange oil seal removal

- Use oil seal puller (special service tool) to remove oil seal.

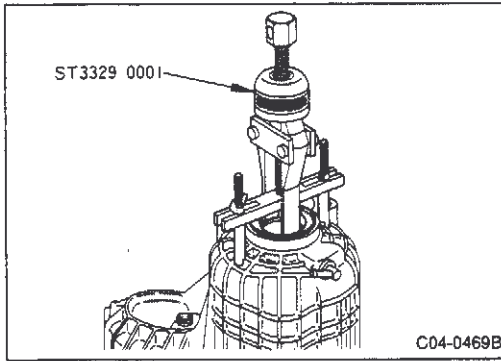

Center drive shaft rear bearing removal

- Use snap ring pliers to remove snap ring.

CAUTION:

Replace snap ring after every disassembly.

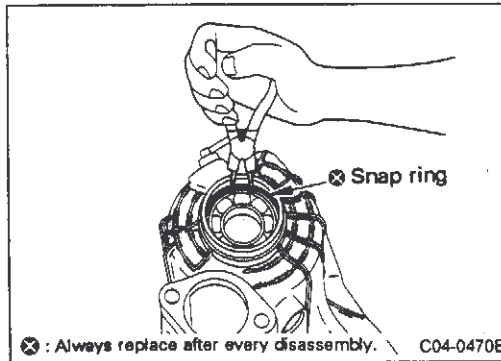

- Use drift with 50 mm (1.97 in) outer diameter to remove bearing.

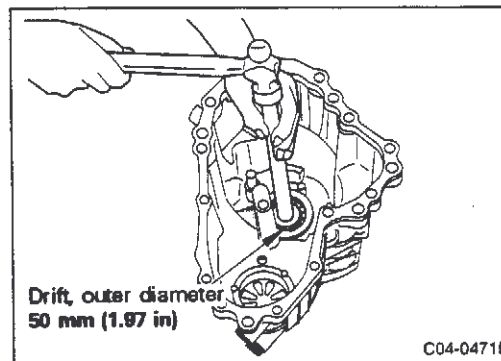

② Assembly and disassembly

ⓐ Oil pump

Disassembly inspection

Check side clearance of inner and outer gear.

- Use depth gauge to measure housing depth as shown in figure.
- Select a set of inner and outer gears which conform to gear and housing clearances indicated below.

Clearance standard:

0.02 - 0.04 mm (0.0008 - 0.0016 in)

Inner gear and outer gears

Gear thickness mm (in)	Part number	
	Inner gear	Outer gear
6.98 (0.2748)	31346 05U02	31347 05U02
6.99 (0.2752)	31346 05U01	31347 05U01
7.00 (0.2756)	31346 05U00	31347 05U00

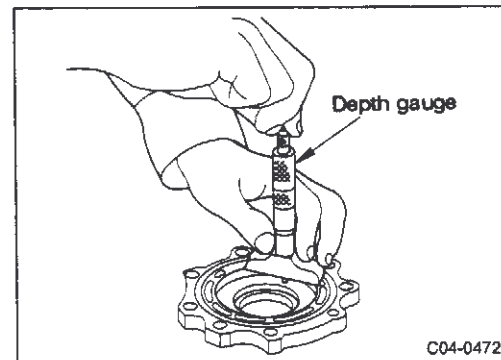

C3 ELECTRICAL CONTROL TORQUE SPLIT 4WD SYSTEM (ATTESSA E-TS)

4. Removal and Installation, Assembly and Disassembly (Cont'd)

Oil strainer inspection

- Check for scratches or damage to oil strainer screen and body.

CAUTION:

Wash screen section well and remove all metallic deposits and foreign matter.

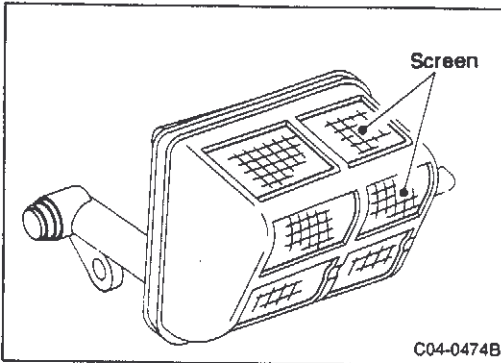

ⓑ Front case

Front drive shaft oil seal removal and installation

Removal

- Position oil seal puller (special service tool) and remove seal as shown in figure.

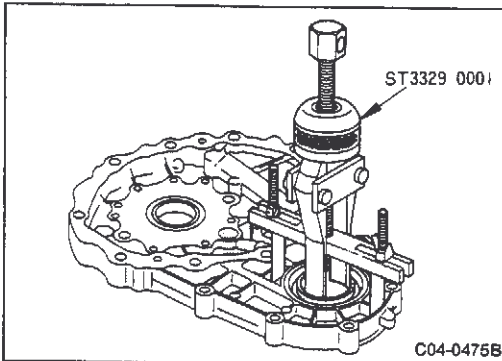

Installation

- Use a drift (special service tool) and install oil seal flush with case surface.

CAUTION:

Apply a thin coat of grease (Nissan MP special grease No. 2) to oil seal lip.

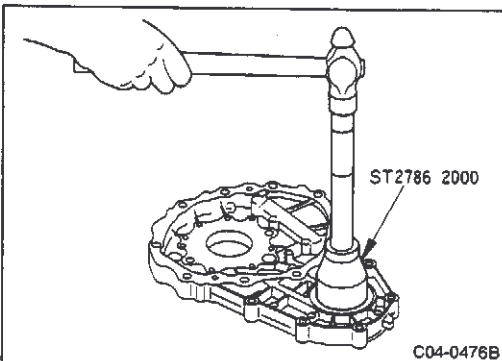

Striking rod oil seal (M/T only) removal and installation

Removal

- Use screwdriver to remove oil seal.

CAUTION:

Be careful not to scratch front case with screwdriver.

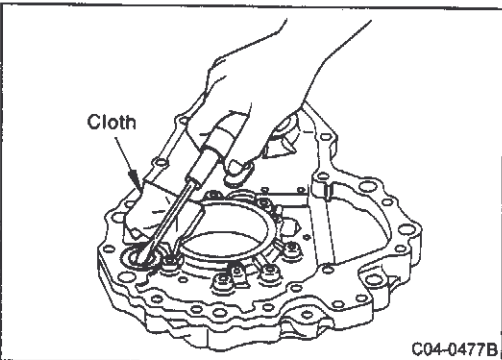

Installation

- Use suitable drift with outer diameter 34 mm (1.34 in) and install oil seal flush with case.

CAUTION:

Apply a thin coat of grease (Nissan MP special grease No. 2) to oil seal lip.

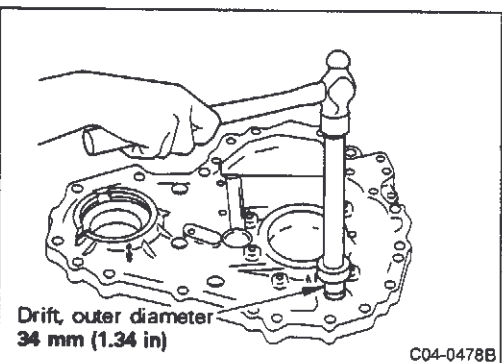

C3 ELECTRICAL CONTROL TORQUE SPLIT 4WD SYSTEM (ATTESSA E-TS)

4. Removal and Installation, Assembly and Disassembly (Cont'd)

Disassembly inspection

- Check that front case one-way valve has not seized.
- Wash front case to remove any sealant that adheres to screws because oil pump bolts (7 locations shown in figure) are seal bolts.

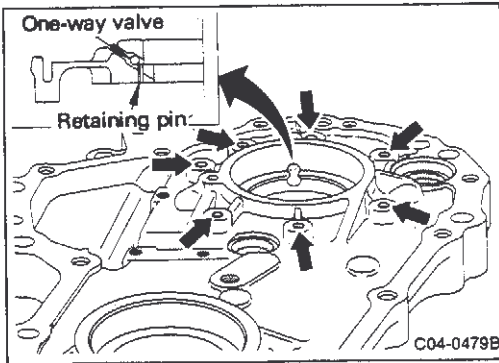

ⓐ Center drive shaft

Clutch drum ASSY and speedometer drive gear removal

- Set center drive shaft in press as shown in figure and separate clutch drum ASSY and speedometer drive gear.

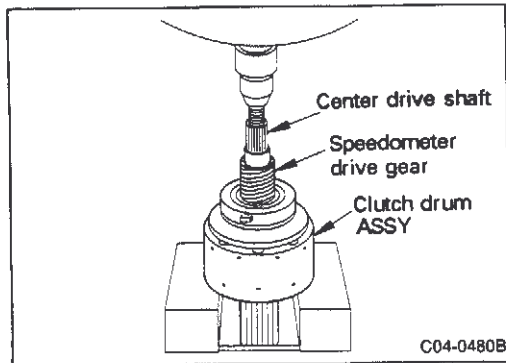

Pressure flange removal

- Position spring compressor (special service tool), press in release bearing retainer and use screwdriver to remove snap ring.

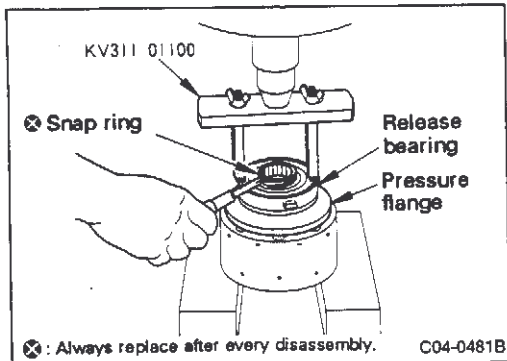

- Remove pressure flange and return spring from clutch drum.

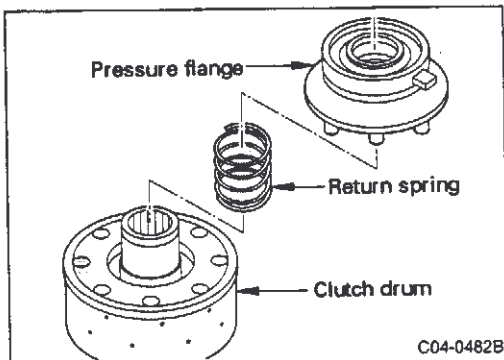

Release bearing removal

- Set bearing replacer on release bearing retainer and use drift with 50 to 60 mm (1.97 to 2.36 in) outer diameter to press out bearing.

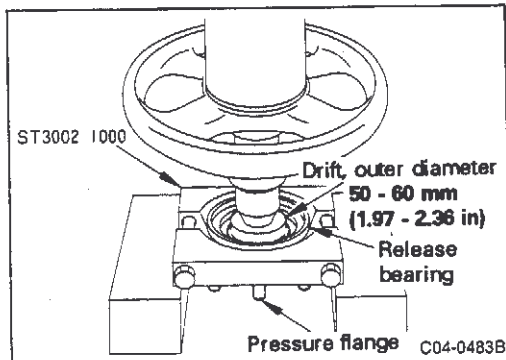

C3 ELECTRICAL CONTROL TORQUE SPLIT 4WD SYSTEM (ATTESSA E-TS)

4. Removal and Installation, Assembly and Disassembly (Cont'd)

- Set bearing replacer (special service tool) on bearing retainer as shown in figure and use drift with outer diameter 65 - 70 mm (2.56 - 2.76 in) to remove bearing.

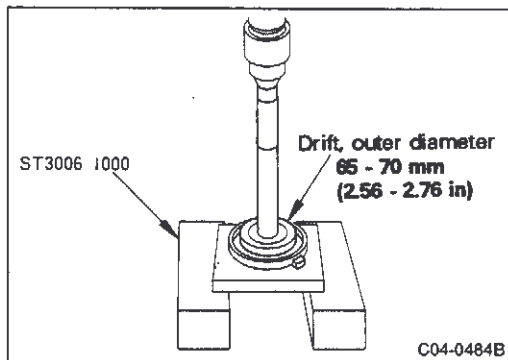

Clutch hub removal

- Use screwdriver to remove thrust washer ring.

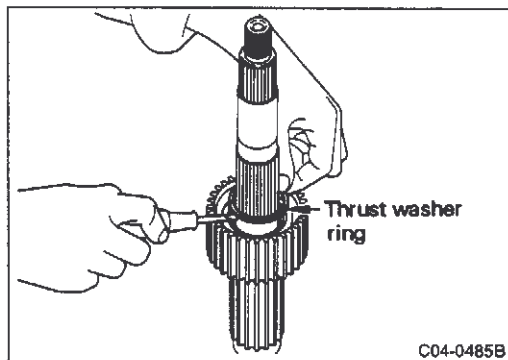

- Use screwdriver to remove thrust washer.

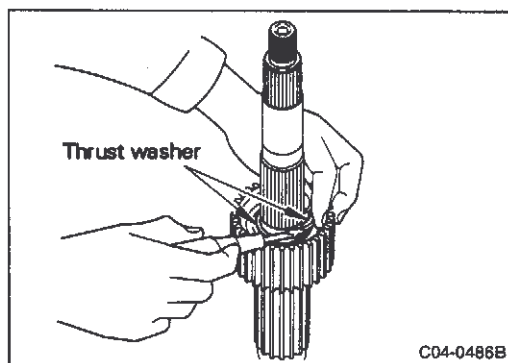

- Use screwdriver as shown in figure to separate needle bearing assemblies into two parts and remove them.

CAUTION:

- (1) Press clutch hub down to separate needle bearings.
- (2) Be careful not to scratch needle bearings.

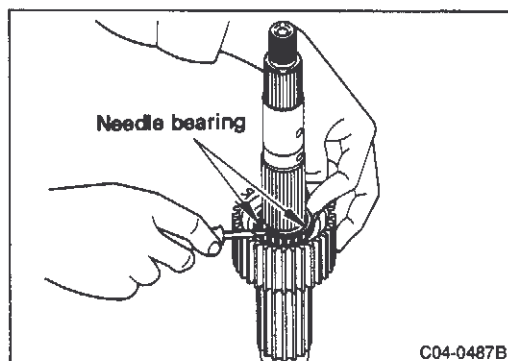

- Remove clutch hub from center drive shaft.

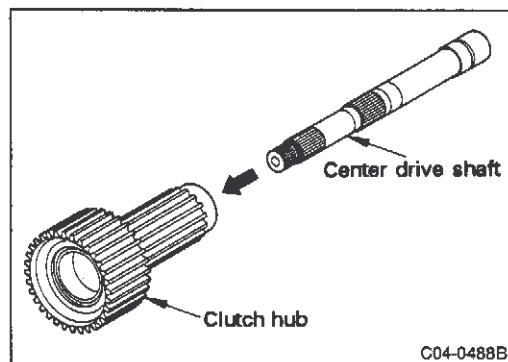

C3 ELECTRICAL CONTROL TORQUE SPLIT 4WD SYSTEM (ATTESSA E-TS)

4. Removal and Installation, Assembly and Disassembly (Cont'd)

Clutch hub installation

- Assemble clutch hub on center drive shaft. Press clutch hub down as shown in figure to increase center drive shaft clearance and install needle bearings.

CAUTION:

- (1) First coat needle bearings with Nissan Multi-fluid D and then assemble.
- (2) When assembling needle bearings, be especially careful not to bend, twist or deform bearings.

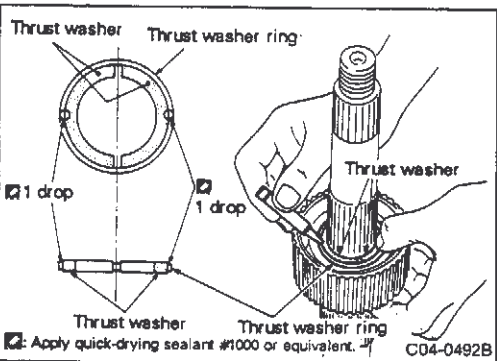
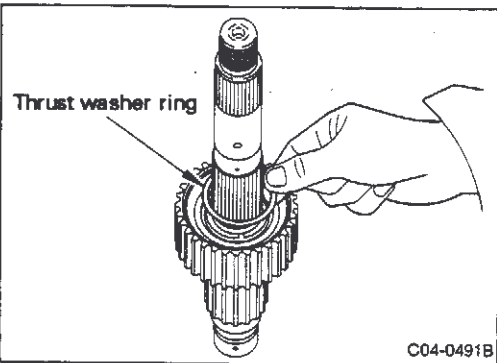
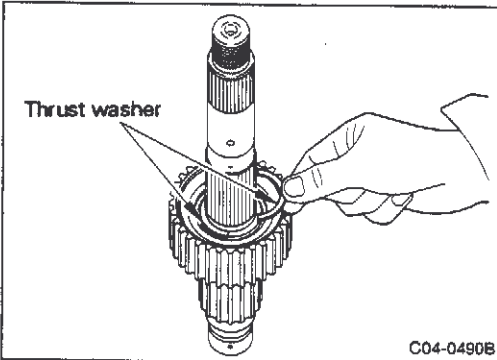
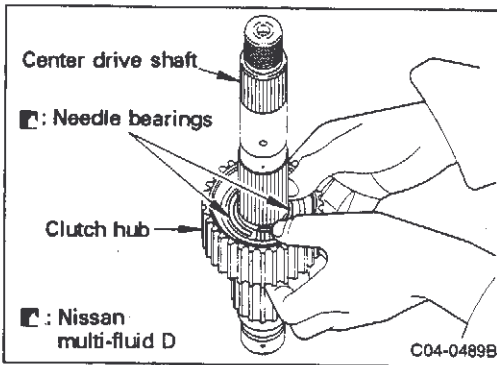

- Install thrust washer in center drive shaft groove.

- Install thrust washer ring outside thrust washer.

- While raising clutch hub, apply a drop of quick-drying sealant #1000 in clearance of thrust washer and thrust washer ring to secure assembly. At this time, be careful that thrust washer ring is not higher than thrust washer surface level.

CAUTION:

- (1) If thrust washer is higher than thrust washer ring, the thrust washer ring may fall off when pressure is applied to clutch drum.
- (2) Be careful not to apply an excessive amount of quick-drying sealant to prevent needle bearings from seizing.

Release bearing ASSY installation

- Set bearing retainer on release bearing. Position plate as shown in figure and press-fit to install.

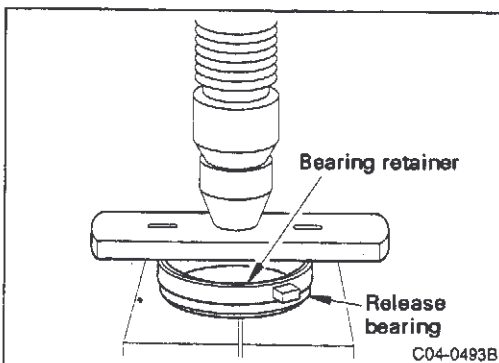

C3 ELECTRICAL CONTROL TORQUE SPLIT 4WD SYSTEM (ATTESSA E-TS)

4. Removal and Installation, Assembly and Disassembly (Cont'd)

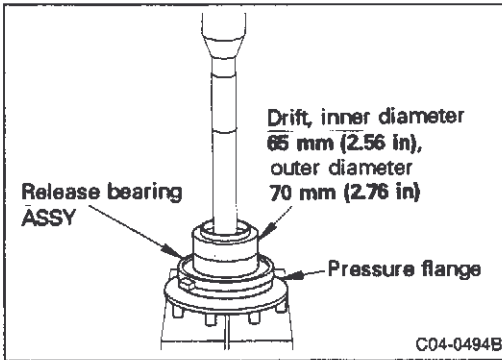

- Place release bearing ASSY on pressure flange. Set drift, with inner diameter 65 mm (2.56 in), outer diameter 70 mm (2.76 in) on release bearing and press-fit to install.

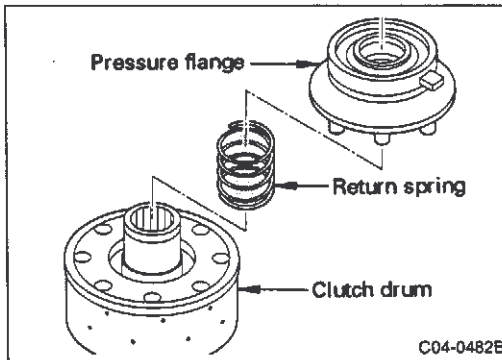

Pressure flange installation

- Install return spring and pressure flange on clutch drum as shown in figure.

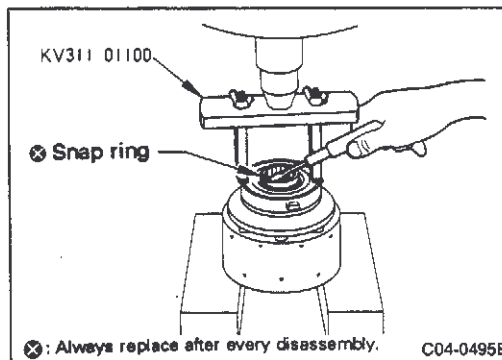

- Set spring compressor (special service tool) as shown in figure. Insert bearing retainer on press and use screwdriver to install snap ring.

CAUTION:

The eight protrusions on pressure flange must be aligned with the eight indentations on clutch drum.

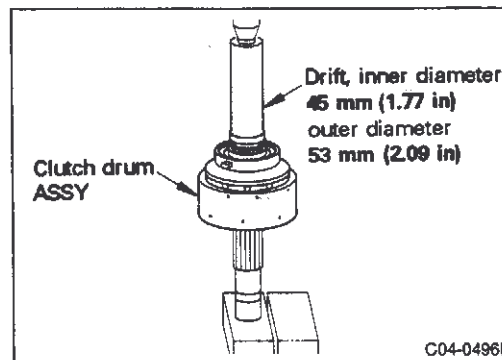

Clutch drum ASSY installation

- Set clutch drum ASSY on center drive shaft rear side. Use drift with 45 mm (1.77 in) inner diameter and 53 mm (2.09 in) outer diameter and press-fit assembly.

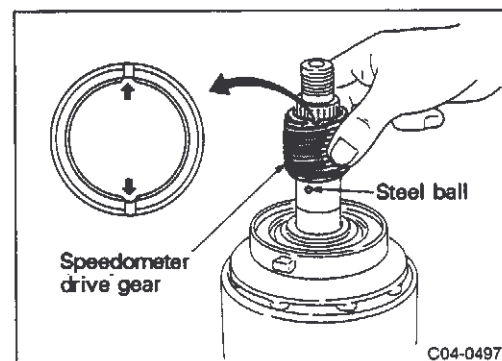

Speedometer drive gear installation

- Assemble steel balls in center drive shaft in positions shown in figure. Align notches (grooves) in speedometer drive gear with steel balls and assemble.

CAUTION:

The notches in speedometer drive gear should face up.

C3 ELECTRICAL CONTROL TORQUE SPLIT 4WD SYSTEM (ATTESSA E-TS)

4. Removal and Installation, Assembly and Disassembly (Cont'd)

- Set drift with 33 mm (1.30 in) inner diameter and 39 mm (1.54 in) outer diameter on drive gear and install on press.

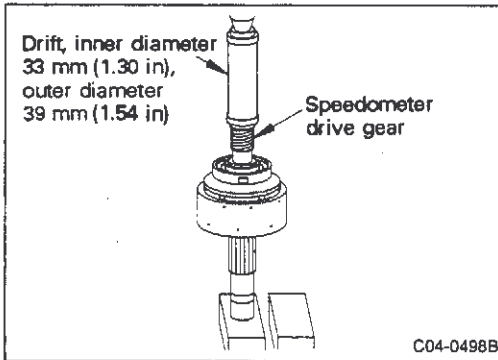

Front bearing removal and installation

Removal

- Set drift with outer diameter 39 mm (1.54 in) on bearing and use puller to remove bearing.

CAUTION:

Be careful not to scratch sliding surface of front oil seal.

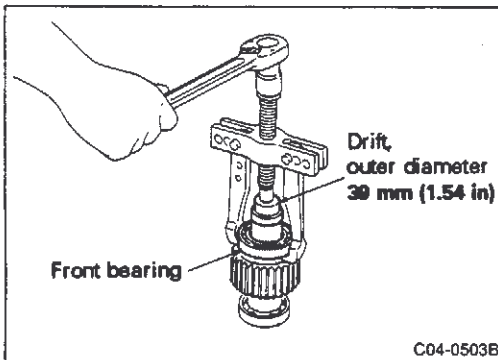

Ⓒ Front drive shaft

Installation

- Set drift with inner diameter 35 mm (1.38 in) on bearing and press to install bearing.

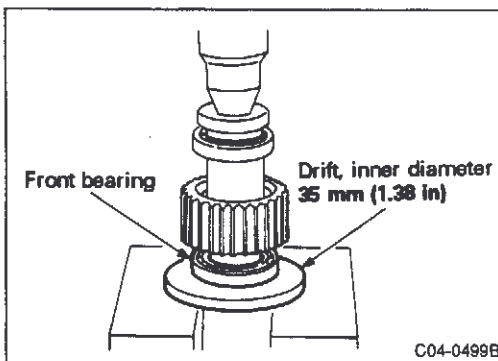

Rear bearing removal and installation

Removal

- Set drift with outer diameter 35 mm (1.38 in) and use puller to remove bearing.

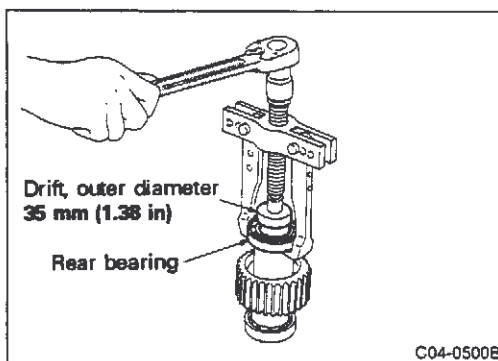

Installation

- Set drift with inner diameter 40 mm (1.57 in) on bearing and use press to install.

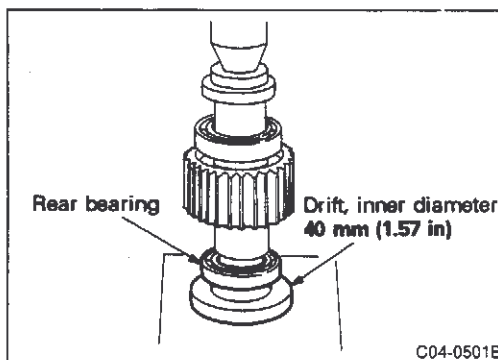

C3 ELECTRICAL CONTROL TORQUE SPLIT 4WD SYSTEM (ATTESSA E-TS)

4. Removal and Installation, Assembly and Disassembly (Cont'd)

③ Installation

Center shaft rear bearing installation

- Use drift with 65 mm (2.56 in) maximum outer diameter and press-fit bearing.

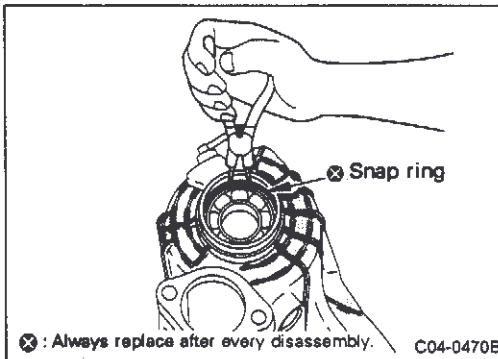
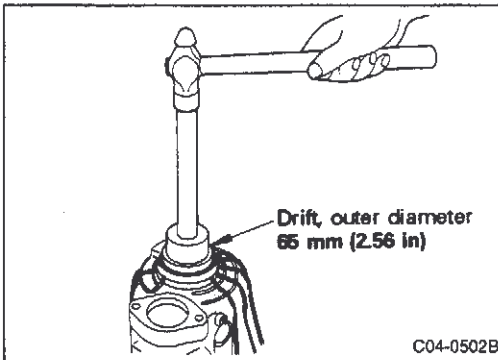

- Use snap ring pliers to install snap ring.

CAUTION:

Replace snap ring after every disassembly.

Companion flange oil seal installation

- Use drift with 63 mm (2.48 in) inner diameter and 68 mm (2.68 in) outer diameter and install seal flush with case.

CAUTION:

Apply a thin coat of grease (Nissan MP special grease No. 2 to oil seal lip.

Reference: Use drift KV401 04830.

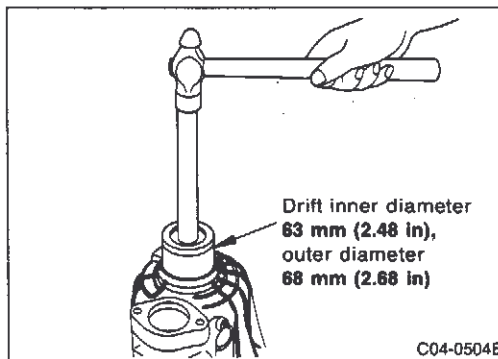

Actuator installation

- Apply a thin coat of grease (Nissan MP special grease No. 2) to actuator boot and install in rear case.
- Tighten bolts to specified tightening torque.

CAUTION:

Do not scratch actuator boot.

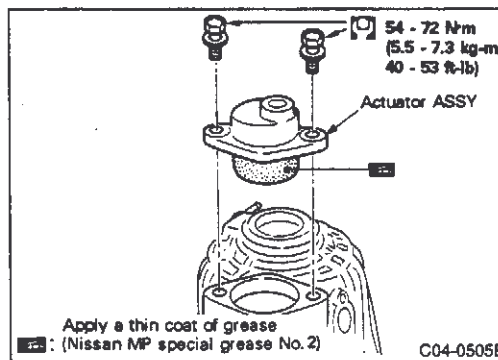

C3 ELECTRICAL CONTROL TORQUE SPLIT 4WD SYSTEM (ATTESSA E-TS)

4. Removal and Installation, Assembly and Disassembly (Cont'd)

Ball pin installation

- Coat ball pin screw with sealant (Three Bond 1324 or equivalent). Use deep socket wrench for removal (refer to figure) and tighten to specified torque.

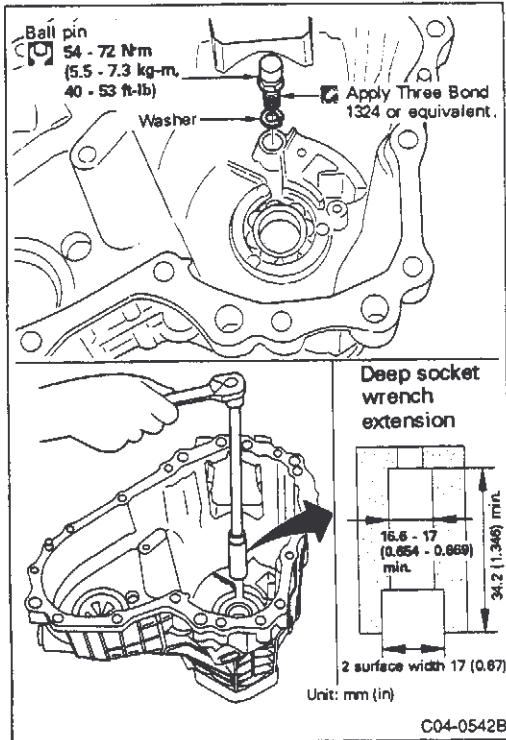

Baffle plate installation

- Install baffle plate on rear case as shown in figure. Tighten two bolts to specified tightening torque.

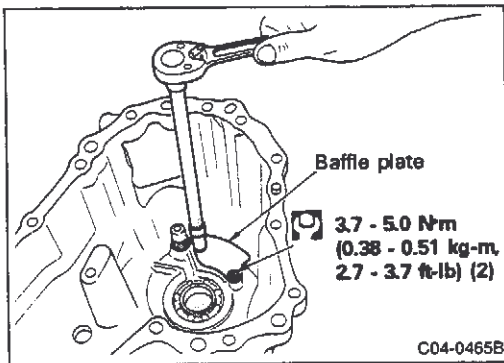

Withdrawal lever installation

- Use snap ring pliers to install retainer spring as shown in figure.

CAUTION:
Align installation direction of spring retainer as shown in figure and install.

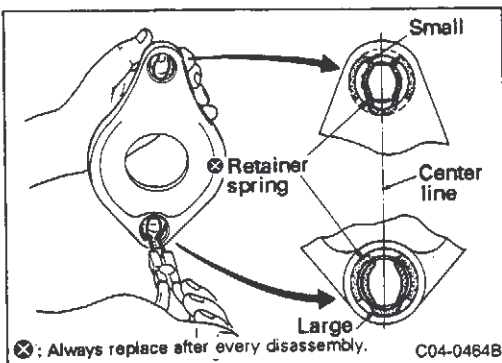

- Install clutch release rod as shown in figure.

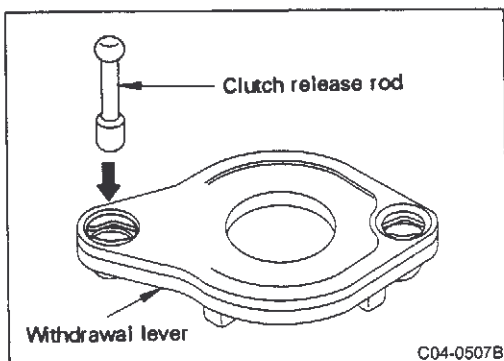

C3 ELECTRICAL CONTROL TORQUE SPLIT 4WD SYSTEM (ATTESSA E-TS)

4. Removal and Installation, Assembly and Disassembly (Cont'd)

- Insert clutch release rod below withdrawal lever in actuator piston. Press spring retainer in ball pin.

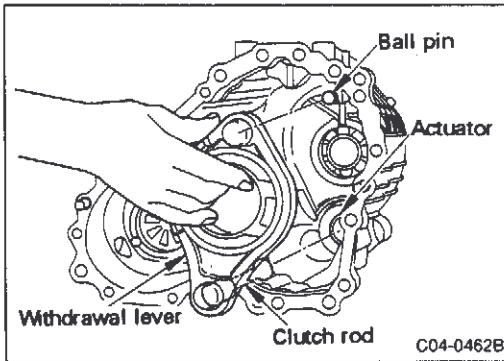

Center drive shaft installation

- Align release bearing retainer protrusion in gap between withdrawal lever protrusions (2 locations) as shown in figure. Press in center drive shaft.

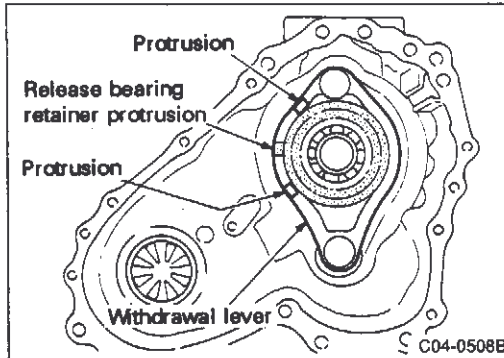

- Install center drive shaft in rear case.
- Assemble companion flange in center drive shaft as shown in figure. Place suitable drift and set in press.
- Align bearing retainer protrusions of center drive shaft with withdrawal lever protrusions (2 locations) and gradually press-fit together. Rotate bearing retainer manually to left and right to check that it contacts withdrawal lever protrusions (2 locations). Press in center drive shaft.

CAUTION:

Press withdrawal lever in straight ahead, making sure it is not inclined. If lever is pressed in at inclined angle, the contact point of withdrawal lever will ride above outside of release bearing retainer and selection of clutch drum retaining plate will not be correct.

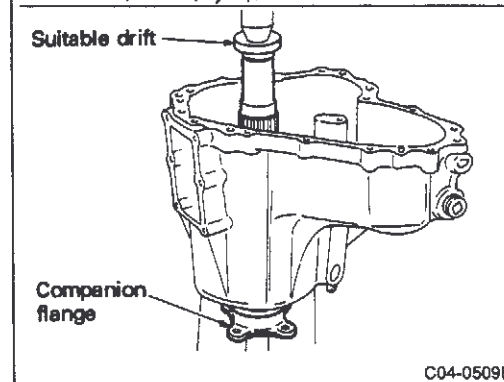
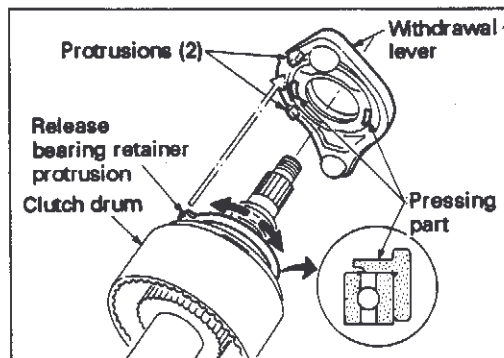

- Place companion flange wrench in companion flange as shown in figure and tighten lock nut to specified tightening torque.

CAUTION:

- (1) Replace lock nut after every disassembly.
- (2) Make sure sliding parts of companion flange oil seal are not scratched or worn.

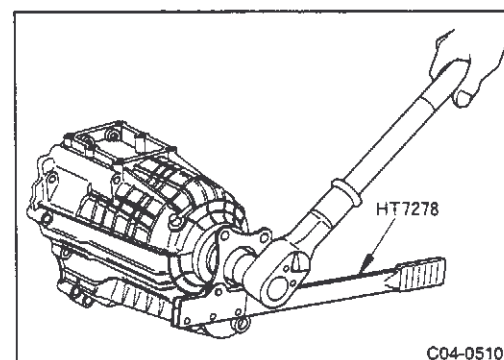

C3 ELECTRICAL CONTROL TORQUE SPLIT 4WD SYSTEM (ATTESSA E-TS)

4. Removal and Installation, Assembly and Disassembly (Cont'd)

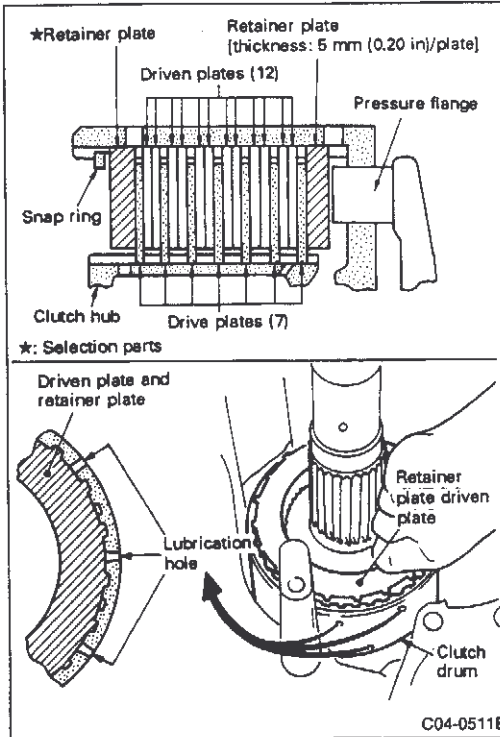

Clutch plate installation

- Make sure clutch plate is assembled correctly in sequence indicated in figure.

CAUTION:

- (1) Assemble clutch drum so lubrication holes are not aligned with gear teeth positions of driven plate and retainer plate.
- (2) After assembling one retainer plate that is 5 mm (0.20 in) thick, install driven plate with drive plate.

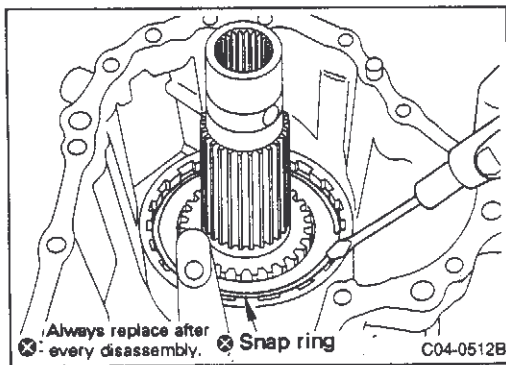

- Use screwdriver to install snap ring.

CAUTION:

Replace snap ring after every disassembly

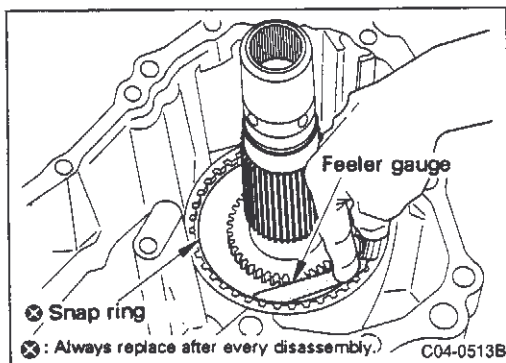

Gap measurement and retainer plate selection

- Use feeler gauge to measure gap between retainer plate and snap ring as shown in figure. If clearance is not within specification range in following chart, select thicker retainer plate to obtain correct clearance.

Inspection standard values

Standard value:

0.2 - 0.5 mm (0.008 - 0.020 in)

Thickness mm (in)	Part number	Thickness mm (in)	Part number
4.8 (0.189)	31537 05U00	6.0 (0.236)	31537 05U06
5.0 (0.197)	31537 05U01	6.2 (0.244)	31537 05U07
5.2 (0.205)	31537 05U02	6.4 (0.252)	31537 05U08
5.4 (0.213)	31537 05U03	6.6 (0.260)	31537 05U09
5.6 (0.220)	31537 05U04	6.8 (0.268)	31537 05U10
5.8 (0.228)	31537 05U05	7.0 (0.276)	31537 05U11

C3 ELECTRICAL CONTROL TORQUE SPLIT 4WD SYSTEM (ATTESSA E-TS)

4. Removal and Installation, Assembly and Disassembly (Cont'd)

Spacer installation

- Place drift with 70 mm (2.76 in) outer diameter and 51 mm (2.01 in) inner diameter on spacer and install on press.

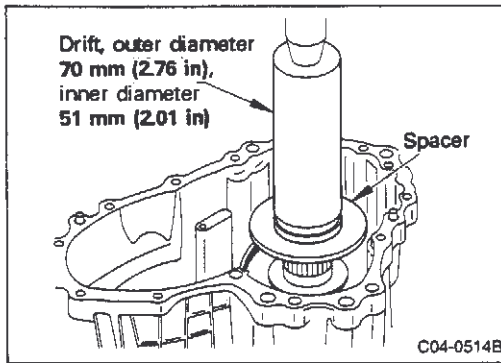

Front drive sprocket installation

- Align installation direction as shown in figure and place drift with 73 mm (2.87 in) outer diameter and 60 mm (2.36 in) inner diameter and press-fit spacer to install.

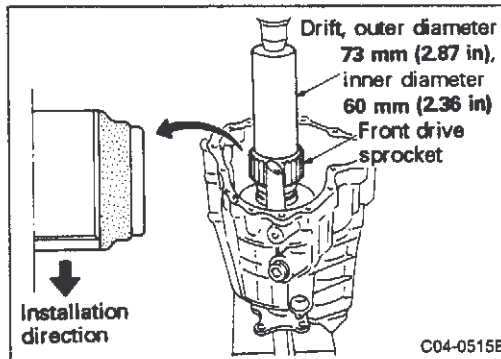

Clutch hub front bearing installation

- Align installation direction as shown in figure. Use drift with 52 mm (2.05 in) outer diameter and 45 mm (1.77 in) inner diameter and press-fit bearing.

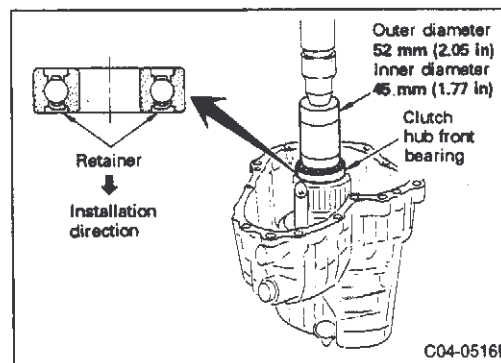

Front drive shaft and drive chain installation

- Attach drive chain on front drive shaft. Align front drive sprocket gears as shown in figure then assemble temporarily.

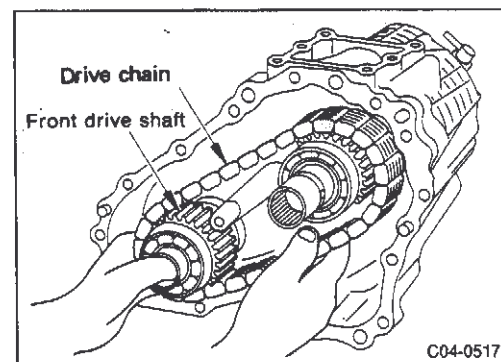

- Align front drive shaft in rear case. Raise front drive shaft and tap with hammer to install.

CAUTION:

- (1) Do not scratch front drive shaft (circumferential friction part) when tapping with wooden hammer.
- (2) Lubricate front propeller shaft engagement spline of front drive shaft with Nissan special grease No. 2.

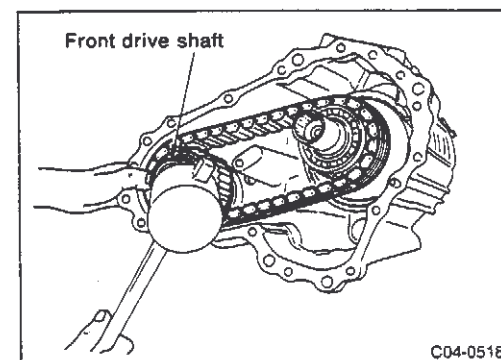

C3 ELECTRICAL CONTROL TORQUE SPLIT 4WD SYSTEM (ATTESSA E-TS)

4. Removal and Installation, Assembly and Disassembly (Cont'd)

Clutch hub end play adjustment

- Use depth gauge and V-block to measure T_1 dimension (adjustment shim thickness) shown in figure. Adjust end play to standard value indicated below.

Inspection standard value

End play standard value:

0.2 - 0.35 mm (0.0079 - 0.0138 in)

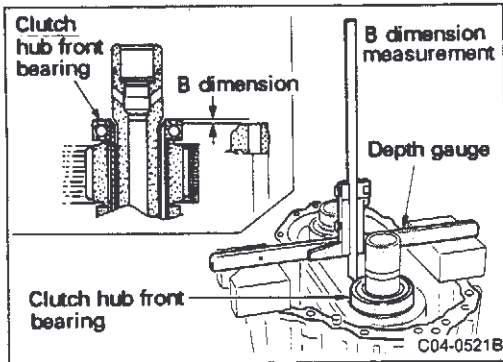
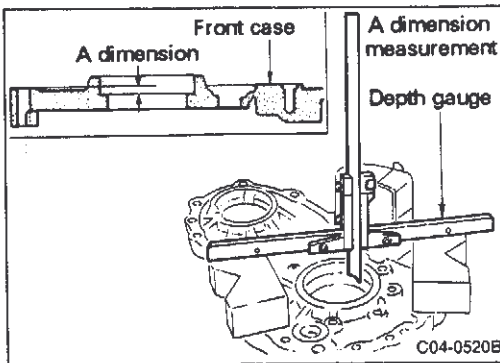
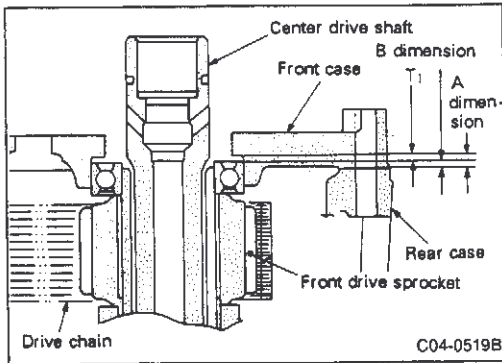

- Place V-block and depth gauge in front case as shown in figure. Measure dimension A to clutch hub front bearing surface.

- Place V-block and depth gauge in rear case as shown in figure. Measure dimension B to clutch hub front bearing surface.

- Use following equation to calculate adjustment shim thickness.

Unit: mm

$$T_1 \text{ (shim thickness)} = A - B - (0.2 \text{ to } 0.35) \text{ (end play standard value)}$$

Adjustment shims

Thickness mm (in)	Part number	Thickness mm (in)	Part number
0.4 (0.016)	33112 05U04	0.8 (0.031)	33112 05U02
0.5 (0.020)	33112 05U05	0.9 (0.035)	33112 05U03
0.6 (0.024)	33112 05U00	1.0 (0.039)	33112 05U06
0.7 (0.028)	33112 05U01		

C3 ELECTRICAL CONTROL TORQUE SPLIT 4WD SYSTEM (ATTESSA E-TS)

4. Removal and Installation, Assembly and Disassembly (Cont'd)

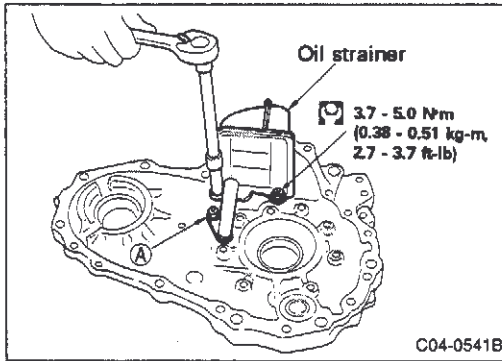

Oil strainer installation

- Install oil strainer in front case as shown in figure. Tighten bolts to specified tightening torque.

CAUTION:

Tighten bolt A first to prevent incorrect installation due to strainer deformation.

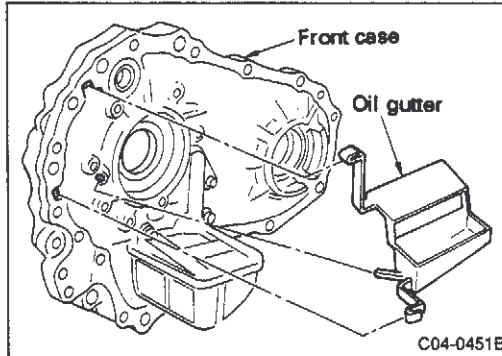

Oil gutter installation

- Align two pawls and tube in front case as shown in figure and assemble securely.

CAUTION:

Do not damage pawls.

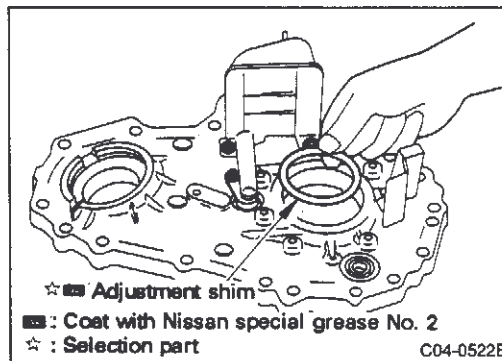

Front case installation

- Coat selected adjustment shim with Nissan MP special grease No. 2 and install it on clutch hub front bearing mating surface.

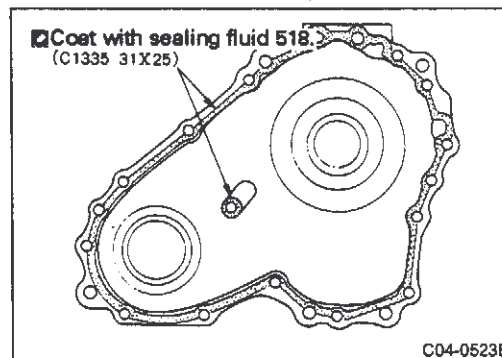

- Coat entire circumference of rear case installation surface as shown in figure on left with sealant (sealing fluid 518 [part number C1335 31X25] or equivalent).

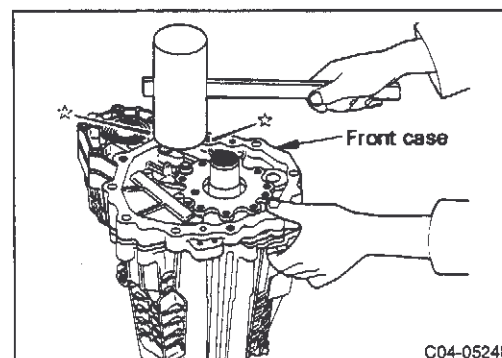

- Align front case with drive shaft and center drive shaft in rear case and tap with wooden hammer to install.

CAUTION:

Do not damage front case or transmission installation surface.

C3 ELECTRICAL CONTROL TORQUE SPLIT 4WD SYSTEM (ATTESSA E-TS)

4. Removal and Installation, Assembly and Disassembly (Cont'd)

- Install front cover bolts as shown in figure and tighten to specified tightening torque.

Bolt	Description	Tightening torque N-m (kg-m, ft-lb)	Length from head mm (in)
A (11 bolts)		16 - 21 (1.6 - 2.1, 12 - 15)	45 (1.77)
B (1 bolt)			165 (6.50)
C (1 bolt)			120 (4.72)
D (1 bolt)			100 (3.94)
E (1 bolt)			45 (1.77)

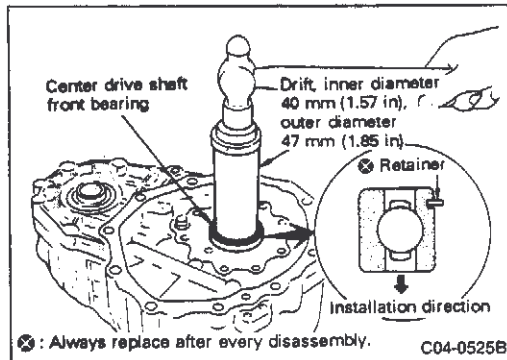
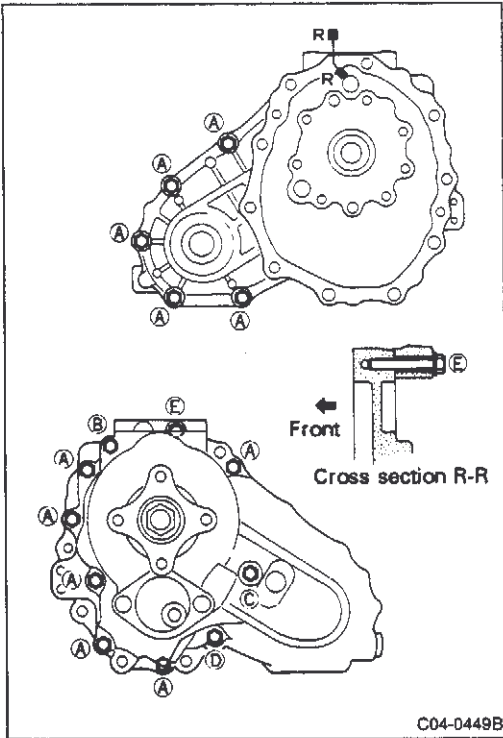

Center drive shaft front bearing installation

- Use suitable drift with 40 mm (1.57 in) inner diameter and 47 mm (1.85 in) outer diameter and press bearing retainer flush with end of case.

CAUTION:

The retainer must be pressed straight into case without binding.

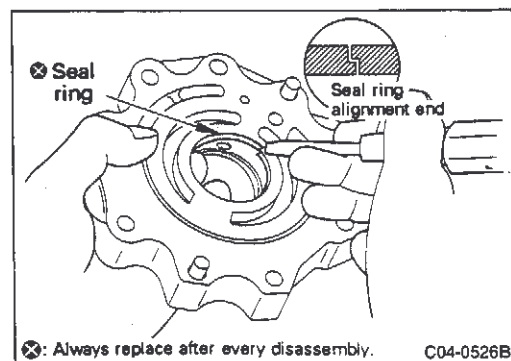

Oil pump installation

- Use screwdriver and install seal ring in groove of oil pump cover.

CAUTION:

- (1) Position seal ring alignment ends as shown in figure.
- (2) Replace seal ring after every disassembly.

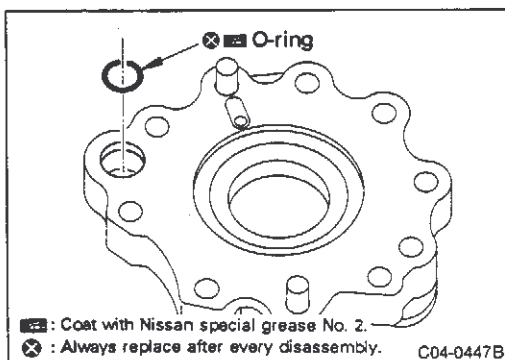

- Coat O-ring with Nissan special grease No. 2 and install in oil strainer of oil pump cover.

CAUTION:

Always replace O-ring after every disassembly.

C3 ELECTRICAL CONTROL TORQUE SPLIT 4WD SYSTEM (ATTESSA E-TS)

4. Removal and Installation, Assembly and Disassembly (Cont'd)

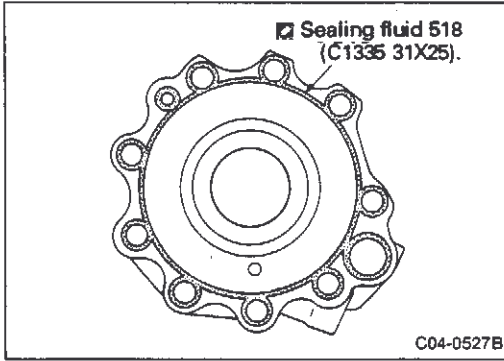

- Coat entire circumference of cover mating surface with sealant (sealing fluid 518 < Part number C1335 31X25 >).

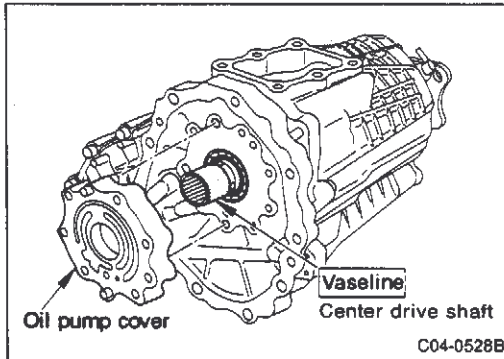

- Coat center drive shaft with Vaseline in position shown in figure. Install oil pump cover in front case.

CAUTION:

Do not scratch center drive shaft with oil pump cover seal ring.

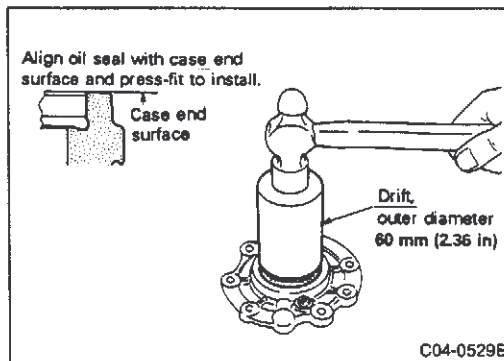

- Use drift with 60 mm (2.36 in) outer diameter and insert oil seal.

CAUTION:

Coat oil seal lip with grease (Nissan MP special grease No. 2).

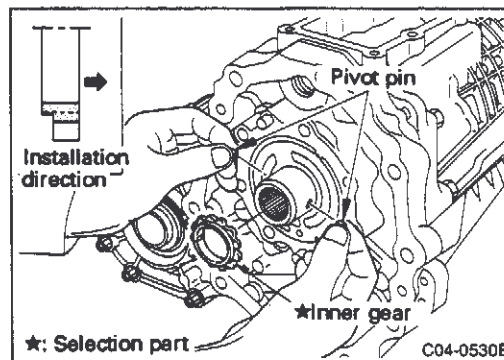

- Install two pivot pins in center drive shaft then install inner gear.

C3 ELECTRICAL CONTROL TORQUE SPLIT 4WD SYSTEM (ATTESSA E-TS)

4. Removal and Installation, Assembly and Disassembly (Cont'd)

- Install outer gear in oil pump housing.

CAUTION:

Inner gear must be aligned with inner gear installation direction.

- Coat O-ring with grease (Nissan MP special grease No. 2) and install in oil pump housing.

CAUTION:

Replace O-ring after every disassembly.

- Assemble housing temporarily. Rotate companion flange as shown in figure, align inner and outer gear position and install housing. Tighten six bolts and one torx bolt to specified tightening torque.

CAUTION:

- (1) There are two knock pins in cover. Align housing side pin holes and then assemble.
- (2) Use tap to coat the bolt holes on case side with sealant.
- (3) Replace bolts and screws after every disassembly.

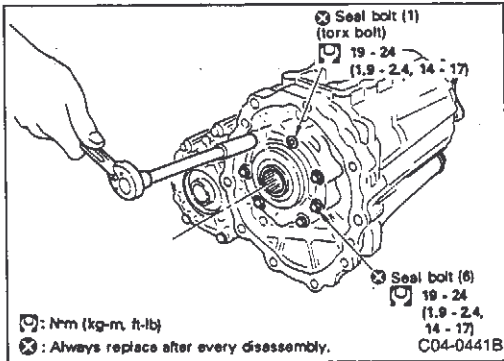
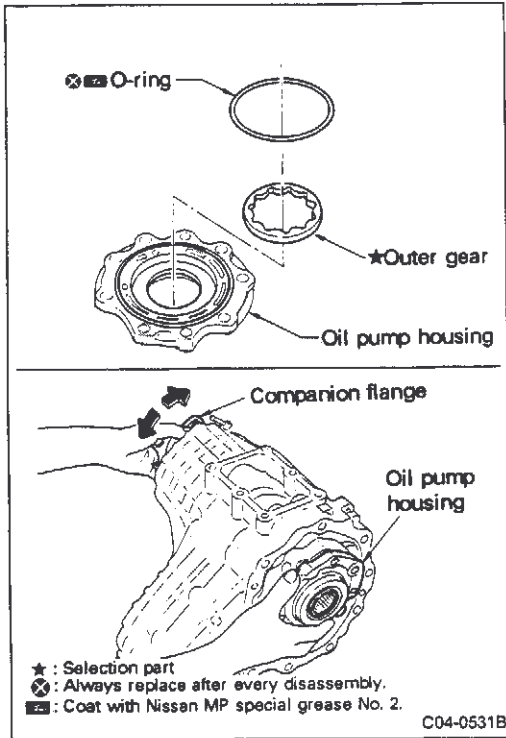

- Tighten seven bolts (including 1 torx bolt) to specified torque.

CAUTION:

Do not reuse installation bolts because these are seal bolts.

C4 PROPELLER SHAFT

OPERATION PRECAUTIONS

- Use torque wrench to tighten nuts and bolts to specified torque.
- When model 3F80A-VL107 propeller shaft removal and installation or shipping is performed, be sure boot of constant velocity joint is not folded or bent. Protect the boot completely since it may be damaged (scratched or cracked).

SPECIAL SERVICE TOOLS

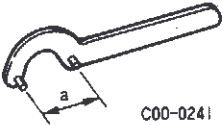
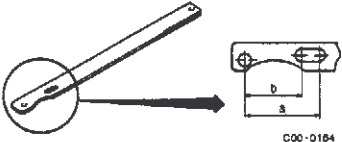
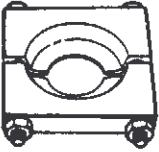
Part name Part number	Description	
Flange wrench ST3154 0000 a ≅ 63 mm (2.48 in)	 <p style="text-align: center;">C00-024</p>	Rear propeller shaft 1st and 2nd propeller shaft separation
Cam sprocket wrench KV101 09900 a ≅ 100 mm (3.94 in) b ≅ 54 mm (2.13 in)	 <p style="text-align: center;">C00-0164</p>	Companion flange removal
Bearing replacer ST3003 1000	 <p style="text-align: center;">C00-0014</p>	Center bearing removal

1. Summary

The journal cannot be disassembled from the 2S56 model propeller shaft. The journal and constant velocity joint cannot be disassembled from the 3F80A-VL107 model propeller shaft. This section describes the removal and installation of 3F80A-VL107 from the vehicle and center bearing removal and installation.

Specifications

Front

	Engine	RB26DETT
	Transmission	M/T
Description		
Model number		2S56A
Length	mm (in)	629 (24.76)
Outer diameter	mm (in)	31.8 + 40 (1.252 + 1.575)
Journal bearing form		Shell type (cannot be disassembled)

C4 PROPELLER SHAFT

1. Summary (Cont'd)

Rear

		Engine	RB26DETT
Description			
Model			3F80A-VL107
Length	mm (in)	1st tube	392 (15.43)
		2nd tube	597 (23.50)
Outer diameter	mm (in)	1st tube	75.2 (2.961)
		2nd tube	75.2 (2.961)
Journal bearing type		Shell type (cannot be disassembled)	

Inspection standard values

		Part	Front propeller shaft	Rear propeller shaft
Description		Model	2S56A	3F80A-VL107
Journal bearing axial play		mm (in)	0 (0)	
Play distance		mm (in)	0.6 (0.024) max.	
Tightening torque N-m (kg-m, ft-lb)	Front propeller shaft - front final drive		24 - 32 (2.4 - 3.3, 17 - 24)	—
	Transfer unit - rear propeller shaft (1st tube)		—	88 - 98 (9.0 - 10, 65 - 72)
	Rear propeller shaft (1st tube) - center flange		—	64 - 74 (6.5 - 7.5, 47 - 54)
	Rear propeller shaft (2nd tube) - rear final drive		—	64 - 74 (6.5 - 7.5, 47 - 54)

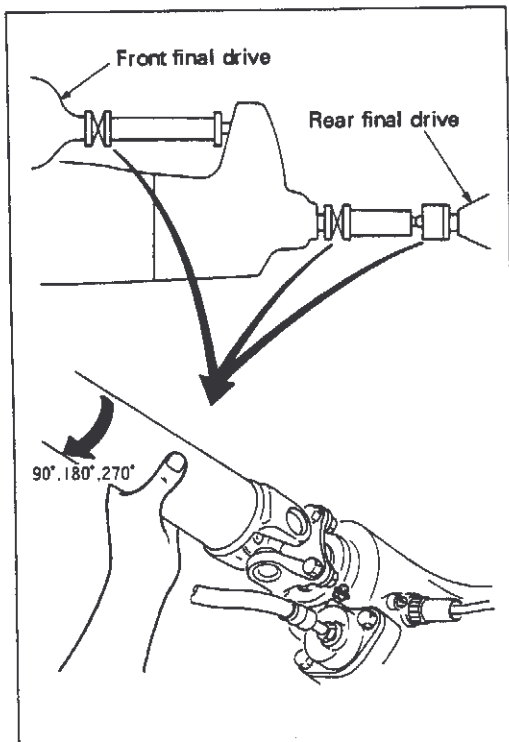

2. On-vehicle Inspection

2-1 PROPELLER SHAFT PLAY INSPECTION

Perform the following procedures for propeller shaft play inspection and repair.

- Remove undercoating and dirt from propeller shaft. Perform driving test to check for propeller play.
- If propeller shaft play is detected, separate propeller shaft and final drive. Move companion flange to offset position of 90°, 180°, 270° (rear final drive is 60°, 120°, 180°, 240°, 300°) and install again.
- Check propeller shaft play in each position by driving test. If propeller shaft play is detected after performing these procedures, replace propeller shaft ASSY.

C4 PROPELLER SHAFT

2. On-vehicle Inspection (Cont'd)

2-2 PROPELLER SHAFT VISUAL INSPECTION AND CENTER BEARING INSPECTION

- Inspect propeller shaft surface for dents or cracks. If damaged, replace propeller shaft assembly.
- If center bearing is noisy or damaged, replace center bearing.

2-3 CONSTANT VELOCITY JOINT INSPECTION

- Check constant velocity joint boot for wear, damage or grease leaks and replace if necessary.

3. Propeller Shaft Removal and Installation, Assembly and Disassembly

3-1 REMOVAL AND INSTALLATION

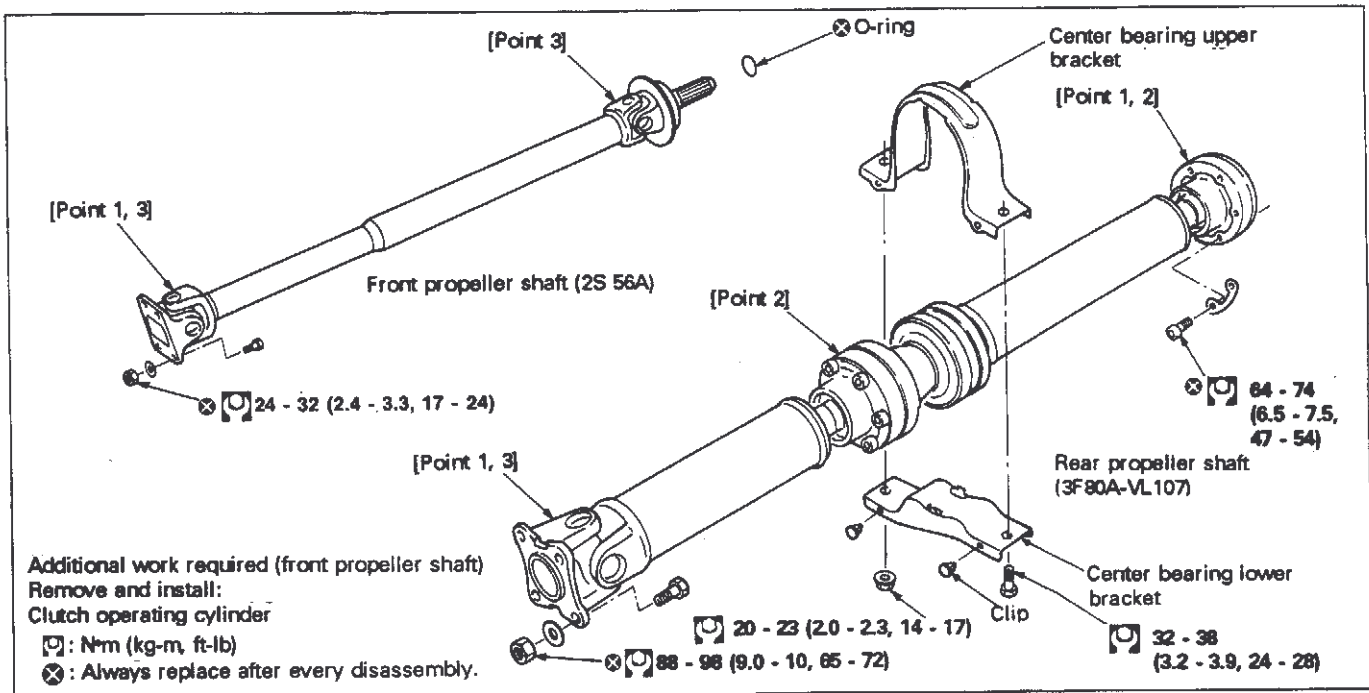

C4 PROPELLER SHAFT

3. Propeller Shaft Removal and Installation, Assembly and Disassembly (Cont'd)

[Point 1] Propeller shaft removal

- Make alignment marks on companion flange before separating connection parts of propeller shaft and final drive and transfer unit as shown in figure.

CAUTION:

Use paint to indicate alignment marks. Do not scratch parts.

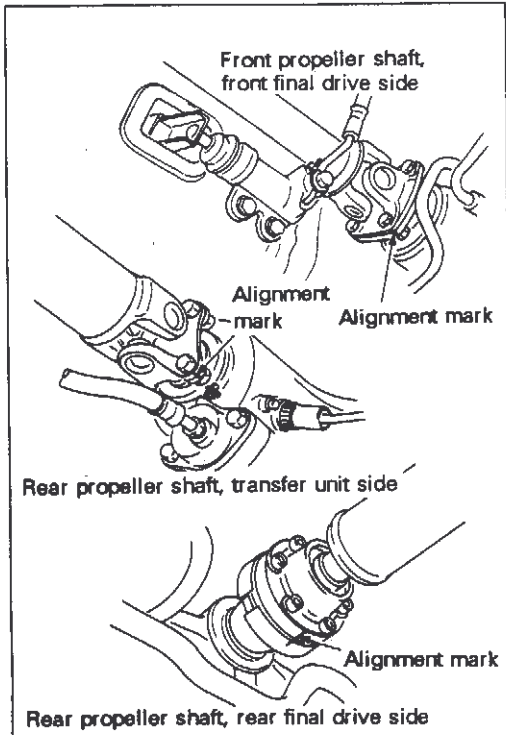

[Point 2] Rear propeller shaft ASSY removal and installation precautions

- When propeller shaft removal and installation or shipping is performed, be sure constant velocity joint is not folded or bent. Protect the boot completely since it may be damaged (scratched or cracked).

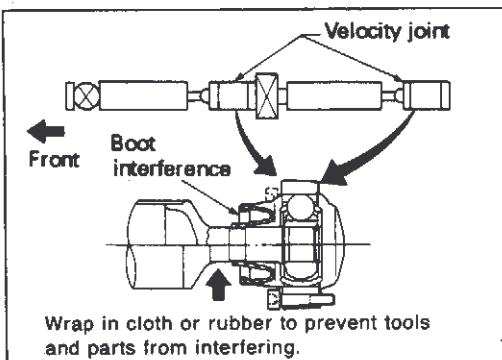

[Point 3] Journal bearing axial play inspection

- Secure the yoke in positions indicated in figure on left and check direction of journal axial play. If play exceeds standard value, replace propeller shaft ASSY.

Axial direction play limit:

0 mm (0 in)

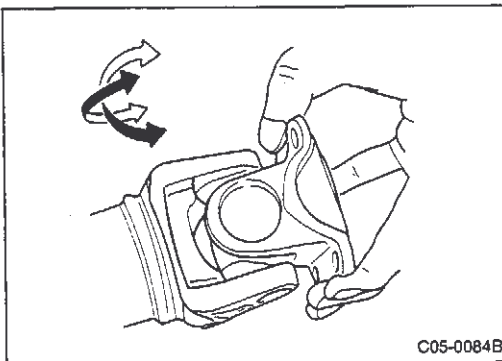

C4 PROPELLER SHAFT

3. Propeller Shaft Removal and Installation, Assembly and Disassembly (Cont'd)

3-2 ASSEMBLY AND DISASSEMBLY

This describes the assembly and disassembly of 3F80A-VL107 propeller shaft center bearing removal and installation.

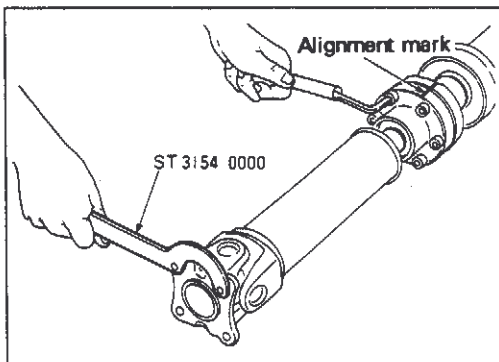
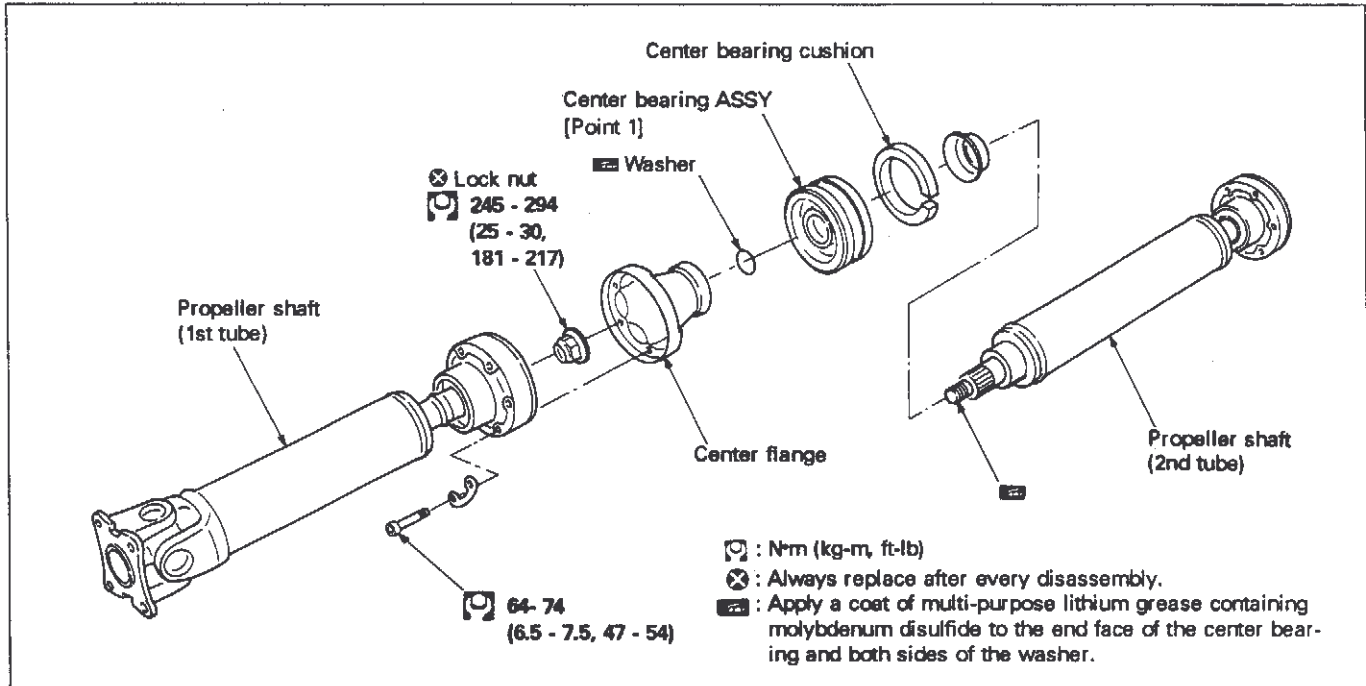

[Point 1] Center bearing removal and installation

Removal

- Make alignment marks on flange and separate 1st and 2nd tubes.

CAUTION:

- (1) At assembly, position alignment marks and then connect parts.
- (2) Paint alignment marks. Do not scratch parts.

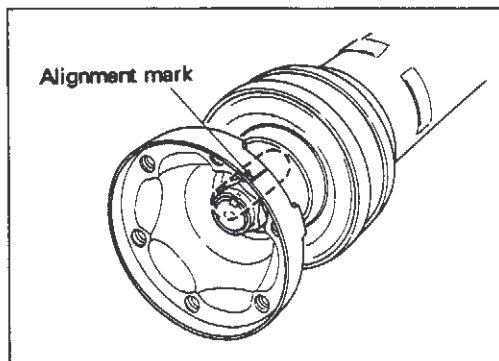

- Make alignment marks on flange and shaft.

CAUTION:

- (1) At assembly, position alignment marks and then connect parts.
- (2) Paint alignment marks. Do not scratch parts.

C4 PROPELLER SHAFT

3. Propeller Shaft Removal and Installation, Assembly and Disassembly (Cont'd)

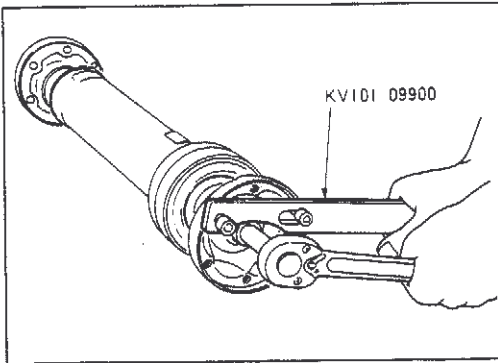

- Use special service tool for propeller shaft bolts and remove lock nuts.

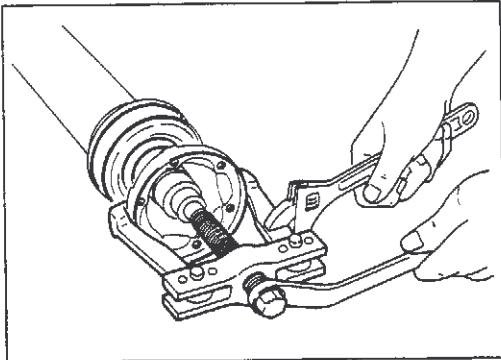

- Use puller to remove companion flange.

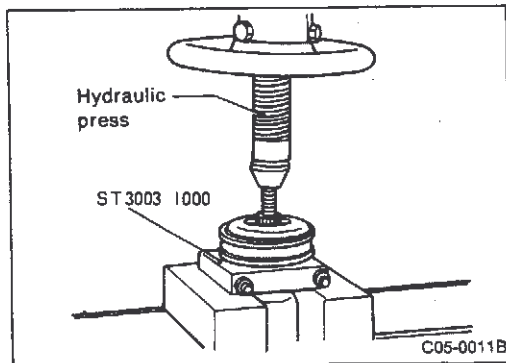

- Use special service tool and hydraulic press to remove center bearing.

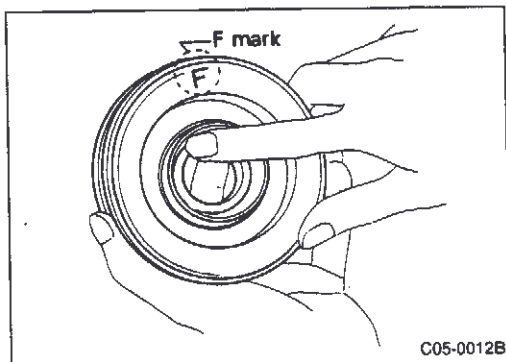

Installation

- Install center bearing with side marked "F" facing front of vehicle.

CAUTION:

Apply a coat of multi-purpose lithium grease (KRI06-00010) containing molybdenum disulfide to the end face of the center bearing and both sides of the washer.

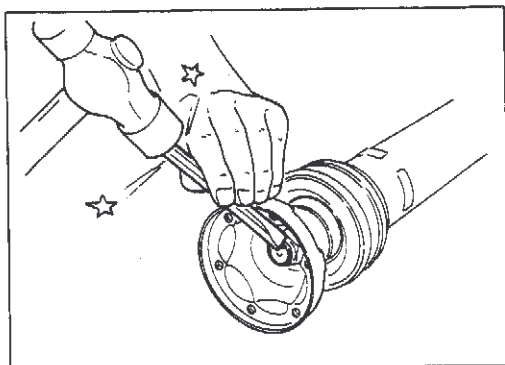

- Tighten lock nut to specified tightening torque and then caulk securely.

CAUTION:

Replace lock nuts after every disassembly.

C5 FINAL DRIVE



OPERATION PRECAUTIONS

- The transmission must always be jacked from the bottom for removal and installation.
- Do not reuse gear oil.
- During removal, installation or disassembly, in final drive or front final drive, do not allow dust, debris or foreign matter to enter the oil pan.
- Use torque wrench to tighten bolts and nuts to specified tightening torque.





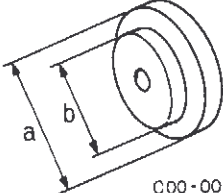

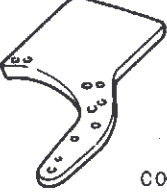
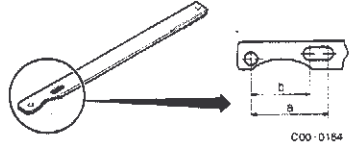
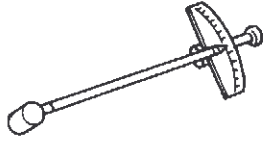
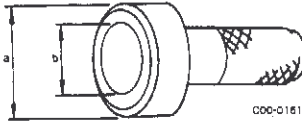
SPECIAL SERVICE TOOLS

Tool name Tool number	Description	
Flange wrench ST3153 0000	a: 80° b: 100° c: 70 mm (2.76 in)	Companion flange removal
	 C00-0029	
Oil seal puller ST3329 0001		Oil seal removal
	 C00-0138	
Drift ST3340 0001	a: 60 mm (2.36 in) dia. b: 47 mm (1.85 in) dia.	Side shaft bearing installation Companion flange, side shaft oil seal installation
	 C00-0158	
Drift KV381 00300	a: 54 mm (2.13 in) dia. b: 46 mm (1.81 in) dia. c: 32 mm (1.26 in) dia.	Right side oil seal installation
	 C00-0156	
Drift ST3672 3000	a: 70 mm (2.76 in) dia. b: 40 mm (1.57 in) dia. c: 29 mm (1.14 in) dia.	Side retainer, side shaft installation
	 C00-0062	
Drift ST3322 0000	a: 32 mm (1.26 in) dia. b: 31.5 mm (1.240 in) dia. c: 21.5 mm (0.846 in) dia.	Side shaft bearing removal
	 C00-0156	

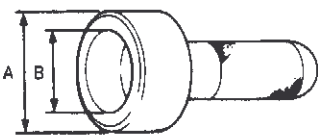

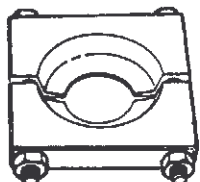
C5 FINAL DRIVE

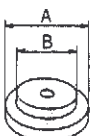
Tool name Tool number	Description
Drift ST3061 3000	<p>a: 72 mm (2.83 in) dia. b: 48 mm (1.89 in) dia.</p>  <p style="text-align: right;">C00-0059</p> <p style="text-align: right;">Left side oil seal installation</p>
Drift bar ST3061 1000	 <p style="text-align: right;">C00-0058</p> <p style="text-align: right;">Drive pinion bearing outer race installation Side oil seal installation Side bearing outer seal installation</p>
Adapter setting plate ST2381 0001	 <p style="text-align: right;">C00-0246</p> <p style="text-align: right;">Side shaft side retainer disassembly</p>
Cam sprocket wrench KV101 09900	<p>a: 100 mm (3.94 in) dia. b: 54 mm (2.13 in) dia.</p>  <p style="text-align: right;">C00-0154</p> <p style="text-align: right;">Companion flange nut removal and installation</p>
Preload gauge ST3127 S000	 <p style="text-align: right;">C00-0039</p> <p style="text-align: right;">Drive pinion rotation resistance measurement</p>
Drift ST3072 0000	<p>a: 77 mm (3.03 in) dia. b: 55.5 mm (2.185 in) dia.</p>  <p style="text-align: right;">C00-0161</p> <p style="text-align: right;">Oil seal installation</p>

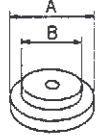
C5 FINAL DRIVE

Tool name Tool number	Description
Drift KV381 00500 ST302 0000	<p>A: 77 mm (3.03 in) dia. B: 55 mm (2.17 in) dia.</p>  <p style="text-align: right;">C00-0055</p> <p>Drive pinion oil seal installation Side shaft oil seal installation (retainer side)</p>
Outer race puller ST3329 0001	 <p style="text-align: right;">C00-0054</p> <p>Side bearing outer race removal Side oil seal removal</p>
Puller set ST3306 S001	 <p style="text-align: right;">C00-0057</p> <p>Side bearing removal</p>
Puller ST3003 1000	 <p style="text-align: right;">C00-0030</p> <p>Drive pinion bearing removal</p>
Drift bar ST3532 5000	 <p style="text-align: right;">C00-0058</p> <p>Drive pinion bearing outer race installation Side oil seal installation</p>
Drift ST3061 2000	<p>A: 62 mm (2.44 in) dia. B: 40 mm (1.57 in) dia.</p>  <p style="text-align: right;">C00-0059</p> <p>Drive pinion bearing outer race installation</p>
Drift ST3323 2000	<p>A: 51 mm (2.01 in) dia. B: 41 mm (1.61 in) dia. C: 28 mm (1.10 in) dia.</p>  <p style="text-align: right;">C00-0156</p> <p>Side bearing installation</p>
Drift ST3532 1000	<p>A: 49 mm (1.93 in) dia. B: 41 mm (1.61 in) dia.</p>  <p style="text-align: right;">C00-0059</p> <p>Side bearing installation Side oil seal installation (gear case side)</p>

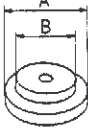

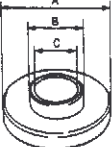
C5 FINAL DRIVE

Tool name Tool number	Description	
Drift ST3062 1000	A: 79 mm (3.11 in) dia. B: 59 mm (2.32 in) dia.	Side bearing outer race installation
		C00-0059
Pin punch KV311 00300		Pinion mate shaft lock pin removal and installation
		C00-0084
Inner race adapter ST3003 2000	A: 80 mm (3.15 in) dia. B: 38 mm (1.50 in) dia. C: 31 mm (1.22 in) dia.	Drive pinion bearing installation Side shaft and retainer installation
		C00-0062

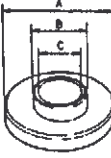
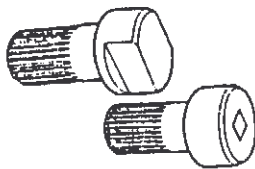
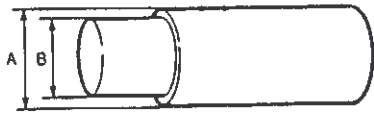
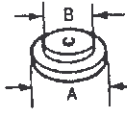
COMMERCIAL SERVICE TOOLS

Tool name Tool number	Description	
Drift ST3090 1000	A: 80 mm (3.15 in) dia. B: 45 mm (1.77 in) dia. C: 35 mm (1.38 in) dia.	Installing drive pinion rear bearing
		
Side flange dummy KV381 051S0		Checking side gear backlash
		
Drift ST337 10000	A: 30 mm (1.18 in) dia. B: 23 mm (0.91 in) dia.	Removing drive pinion
		
Drift ST3306 1000	A: 38 mm (1.50 in) dia. B: 28.5 mm (1.122 in) dia.	Removing drive pinion
		

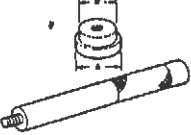
C5 FINAL DRIVE

Tool name Tool number	Description	
Drift ST3323 0000	A: 51 mm (2.01 in) dia. B: 41 mm (1.61 in) dia. C: 28 mm (1.10 in) dia.	Installing side bearing
		
Drift ST3340 0001	A: 60 mm (2.36 in) dia. B: 47 mm (1.85 in) dia.	Installing side oil seal
		
Drift KV381 02200	A: 90 mm (3.54 in) dia. B: 55.3 mm (2.177 in) dia.	Installing drive pinion bearing outer
		
Differential flange tool HT7278		Companion flange nut removal and installation
Torque wrench		Tightening nuts and bolts
Puller		Companion flange removal
Dial gauge test indicator		Hypoid gear backlash measurement, drive gear rear face play measurement, companion flange play measurement
Depth gauge		Side shaft end play calculation

	Name	Application
Preparation equipment	Loctite	Prevents drive gear bolts from loosening
	Liquid gasket (Three Bond 1215)	<ul style="list-style-type: none"> ● Side retainer installation hole ● Carrier case cover ● Drain, filler plug
Oil	Nissan gear oil hypoid LSD GL-5 80W-90 (Rear) GL5-85W-90 (Front)	Lubrication oil

CAUTION:

Gear oil is used at high pressure. Use of non-recommended oils may result in abnormal wear or overheating of gear surfaces.

C5 FINAL DRIVE

1. Summary

This section describes the removal and installation, assembly and disassembly of parts from the side shaft in the front of vehicle. The engine and oil pan are removed and installed as a single unit. Refer to B. Engine, B-Oil Pan Removal and Installation.

1-1 SPECIFICATIONS

(1) Front final drive (F160)

Item		Engine	RB26DETT
		Transmission	M/T
Model number		F160	
Final gear ratio		4.111	
Differential model		2-pinion	
Number of gear teeth	Drive gear/drive pinion	37/9	
	Side gear/pinion mate gear	16/10	
Drive pinion adjustment spacer		Solid	
Oil and volume		ℓ (Imp qt)	Nissan gear oil hypoid GL-5 85W-90 [approx. 1.0 (7/8)]

(2) Rear final drive [R200 (mechanical LSD)]

Item		Engine	RB26DETT
		Transmission	M/T
Model number		R200 (mechanical LSD)	
Final gear ratio		4.111	
Differential type		4-pinion	
Number of gear teeth	Drive gear/drive pinion	37/9	
	Side gear/pinion mate gear	16/10	
Drive pinion adjustment spacer		Solid	
Oil and quantity		ℓ (Imp qt)	Nissan gear oil hypoid LSD GL-5 80W-90 [approx. 1.5 (1-3/8)]

C5 FINAL DRIVE

1. Summary (Cont'd)

1-2 INSPECTION STANDARD VALUES

(1) Front final drive (F160)

Item			Standard value
Ring gear rear surface runout			Deflection limit 0.05 (0.0020) max.
Companion flange deflection mm (in)			
Drive pinion total preload N·m (kg·m, ft·lb)	Drive pinion preload (P)	Oil seal installation	0.8 - 1.1 (0.08 - 0.11, 0.6 - 0.8)
	Total preload	Side shaft installation	1.6 - 2.2 (0.16 - 0.22, 1.2 - 1.6) [P + 0.8 - 1.1 (0.08 - 0.11, 0.6 - 0.8)]
Tightening torque N·m (kg·m, ft·lb)	Drive pinion nut		167 - 196 (17 - 20, 123 - 145)
	Ring gear		93 - 113 (9.5 - 11.5, 69 - 83)
	Side retainer		16 - 19 (1.6 - 1.9, 12 - 14)
	Side shaft		16 - 21 (1.6 - 2.1, 12 - 15)
Side gear rear surface clearance mm (in)			0.05 - 0.15 (0.0020 - 0.0059)

Side gear thrust washer

Thickness mm (in)	Part number	Thickness mm (in)	Part number
0.68 - 0.71 (0.0268 - 0.0280)	38424 W1010	0.86 - 0.89 (0.0339 - 0.0350)	38424 W1016
0.71 - 0.74 (0.0280 - 0.0291)	38424 W1011	0.89 - 0.92 (0.0350 - 0.0362)	38424 W1017
0.74 - 0.77 (0.0291 - 0.0303)	38424 W1012	0.92 - 0.95 (0.0362 - 0.0374)	38424 W1018
0.77 - 0.80 (0.0303 - 0.0315)	38424 W1013	0.95 - 0.98 (0.0374 - 0.0386)	38424 W1019
0.80 - 0.83 (0.0315 - 0.0327)	38424 W1014	0.98 - 1.01 (0.0386 - 0.0398)	38424 W1020
0.83 - 0.86 (0.0327 - 0.0339)	38424 W1015	1.01 - 1.04 (0.0398 - 0.0409)	38424 W1021

T₁: Side bearing adjusting shim (side retainer side)

Thickness mm (in)	Part number	Thickness mm (in)	Part number
0.35 (0.0138)	38453 03V60	0.80 (0.0315)	38453 03V69
0.40 (0.0157)	38453 03V61	0.85 (0.0335)	38453 03V70
0.45 (0.0177)	38453 03V62	0.90 (0.0354)	38453 03V71
0.50 (0.0197)	38453 03V63	0.95 (0.0374)	38453 03V72
0.55 (0.0217)	38453 03V64	1.00 (0.0394)	38453 03V73
0.60 (0.0236)	38453 03V65	1.05 (0.0413)	38453 03V74
0.65 (0.0256)	38453 03V66	1.10 (0.0433)	38453 03V75
0.70 (0.0276)	38453 03V67	1.15 (0.0453)	38453 03V76
0.75 (0.0295)	38453 03V68		

T₂: Side bearing adjusting washer (carrier case side)

Thickness mm (in)	Part number	Thickness mm (in)	Part number
1.93 - 1.97 (0.0760 - 0.0776)	38453 03V00	2.33 - 2.37 (0.0917 - 0.0933)	38453 03V08
1.98 - 2.02 (0.0780 - 0.0795)	38453 03V01	2.38 - 2.42 (0.0937 - 0.0953)	38453 03V09
2.03 - 2.07 (0.0799 - 0.0815)	38453 03V02	2.43 - 2.47 (0.0957 - 0.0972)	38453 03V10
2.08 - 2.12 (0.0819 - 0.0835)	38453 03V03	2.48 - 2.52 (0.0976 - 0.0992)	38453 03V11
2.13 - 2.17 (0.0839 - 0.0854)	38453 03V04	2.53 - 2.57 (0.0996 - 0.1012)	38453 03V12
2.18 - 2.22 (0.0858 - 0.0874)	38453 03V05	2.58 - 2.62 (0.1016 - 0.1031)	38453 03V13
2.23 - 2.27 (0.0878 - 0.0894)	38453 03V06	2.63 - 2.67 (0.1035 - 0.1051)	38453 03V14
2.28 - 2.32 (0.0898 - 0.0913)	38453 03V07		

C5 FINAL DRIVE

1. Summary (Cont'd)

Item	Standard value
Backlash drive gear-drive pinion gear mm (in)	0.13 - 0.18 (0.0051 - 0.0071)

Pinion height adjusting washer

Thickness mm (in)	Part number	Thickness mm (in)	Part number
3.09 (0.1217)	38154 U1500	3.39 (0.1335)	38154 U1510
3.12 (0.1228)	38154 U1501	3.42 (0.1346)	38154 U1511
3.15 (0.1240)	38154 U1502	3.45 (0.1358)	38154 U1512
3.18 (0.1252)	38154 U1503	3.48 (0.1370)	38154 U1513
3.21 (0.1264)	38154 U1504	3.51 (0.1382)	38154 U1514
3.24 (0.1276)	38154 U1505	3.54 (0.1394)	38154 U1515
3.27 (0.1287)	38154 U1506	3.57 (0.1406)	38154 U1516
3.30 (0.1299)	38154 U1507	3.60 (0.1417)	38154 U1517
3.33 (0.1311)	38154 U1508	3.63 (0.1429)	38154 U1518
3.36 (0.1323)	38154 U1509	3.66 (0.1441)	38154 U1519

Pinion bearing preload	N·m (kg·m, ft·lb)	0.8 - 1.1 (0.08 - 0.11, 0.6 - 0.8)
------------------------	-------------------	------------------------------------

Pinion bearing adjustment spacer (solid)

Thickness mm (in)	Part number	Thickness mm (in)	Part number
56.2 (2.213)	38130 21000	56.8 (2.236)	38133 21000
56.4 (2.220)	38131 21000	57.0 (2.244)	38134 21000
56.6 (2.228)	38132 21000	57.2 (2.252)	38135 21000

Pinion bearing adjusting washer

Thickness mm (in)	Part number	Thickness mm (in)	Part number
2.30 - 2.32 (0.0906 - 0.0913)	38141 09400	2.46 - 2.48 (0.0969 - 0.0976)	38133 09400
2.32 - 2.34 (0.0913 - 0.0921)	38140 09400	2.48 - 2.50 (0.0976 - 0.0984)	38132 09400
2.34 - 2.36 (0.0921 - 0.0929)	38139 09400	2.50 - 2.52 (0.0984 - 0.0992)	38131 09400
2.36 - 2.38 (0.0929 - 0.0937)	38138 09400	2.52 - 2.54 (0.0992 - 0.1000)	38130 09400
2.38 - 2.40 (0.0937 - 0.0945)	38137 09400	2.54 - 2.56 (0.1000 - 0.1008)	38129 09400
2.40 - 2.42 (0.0945 - 0.0953)	38136 09400	2.56 - 2.58 (0.1008 - 0.1016)	38128 09400
2.42 - 2.44 (0.0953 - 0.0961)	38135 09400	2.58 - 2.60 (0.1016 - 0.1024)	38127 09400
2.44 - 2.46 (0.0961 - 0.0969)	38134 09400		

Side shaft axial end play	mm (in)	0 - 0.1 (0 - 0.004)
---------------------------	---------	---------------------

Side retainer adjusting shim

Thickness mm (in)	Part number	Thickness mm (in)	Part number
0.08 - 0.12 (0.0031 - 0.0047)	38233 03V01	0.37 - 0.43 (0.0146 - 0.0169)	38233 03V04
0.18 - 0.22 (0.0071 - 0.0087)	38233 03V02		
0.27 - 0.33 (0.0106 - 0.0130)	38233 03V03		
		0.46 - 0.54 (0.0181 - 0.0213)	38233 03V05

C5 FINAL DRIVE

1. Summary (Cont'd)

(2) Rear final drive [R200 (mechanical LSD)]

	Final drive	R200 (mechanical LSD)
Item	Engine	RB26DETT
Ring gear rear runout		Runout limit 0.05 (0.020) max.
Companion flange runout	mm (in)	
Drive pinion total preload	N·m (kg-m, ft-lb)	1.4 - 3.1 (0.14 - 0.32, 1.0 - 2.3)
Side bearing preload	N·m (kg-m, ft-lb)	0.3 - 1.5 (0.03 - 0.15, 0.2 - 1.1)
Pinion nut tightening torque	N·m (kg-m, ft-lb)	186 - 294 (19 - 30, 137 - 217)
Ring gear bolt tightening torque	N·m (kg-m, ft-lb)	177 - 196 (18 - 20, 130 - 145)

Item		Standard value
Side gear rear surface clearance	mm (in)	R200 (mechanical LSD)
		Non-adjustable

Side bearing preload adjusting washer selection calculation equation

$$T_1: \text{Left side (drive gear rear side) washer thickness} \quad T_1 = (A - C + D + E + G) \times 0.01 + 2.07$$

$$T_2: \text{Right side (drive gear, gear tooth side) washer thickness} \quad T_2 = (B - D + F) \times 0.01 + 2.07$$

A: Housing mark [Standard value: 117 mm (4.61 in)] Note 1

B: Housing mark [Standard value: 65 mm (2.56 in)] Note 1

C: Differential case mark [Standard value: 128 mm (5.04 in)] Note 1

D: Differential case mark [Standard value: 97 mm (3.82 in)] Note 1

E: Bearing mark [Standard value: 21 mm (0.83 in)] Note 2

F: Bearing mark [Standard value: 21 mm (0.83 in)] Note 2

G: Spacer mark [Standard value: 8.1 mm (0.319 in)] Note 2

Note 1: Printed mark indicated following value marked by alphabet is based on standard value of 0. It is added to actual measured value in 0.01 increments.

For example: A2 mark indicates 117.02 mm (4.61 in).

Note 2: Printed indicates following value marked by alphabet is based on standard value of 0. It is subtracted from actual measured value in 0.01 increments.

For example: The E3 mark indicates 20.97 mm (0.8256 in).

C5 FINAL DRIVE

1. Summary (Cont'd)

T₁, T₂: Side bearing preload adjusting washer R200 (mechanical LSD)

Thickness mm (in)	Part number	Thickness mm (in)	Part number
2.00 (0.0787)	38453 N3100	2.35 (0.0925)	38453 N3107
2.05 (0.0807)	38453 N3101	2.40 (0.0945)	38453 N3108
2.10 (0.0827)	38453 N3102	2.45 (0.0965)	38453 N3109
2.15 (0.0846)	38453 N3103	2.50 (0.0984)	38453 N3110
2.20 (0.0866)	38453 N3104	2.55 (0.1004)	38453 N3111
2.25 (0.0886)	38453 N3105	2.60 (0.1024)	38453 N3112
2.30 (0.0906)	38453 N3106	2.65 (0.1043)	38453 N3113

Backlash drive gear - drive pinion gear mm (in) 0.13 - 0.18 (0.0051 - 0.0071)

Pinion height adjusting washer R200 (mechanical LSD)

Thickness mm (in)	Part number	Thickness mm (in)	Part number
3.09 (0.1217)	38154 P6017	3.39 (0.1335)	38154 P6027
3.12 (0.1228)	38154 P6018	3.42 (0.1346)	38154 P6028
3.15 (0.1240)	38154 P6019	3.45 (0.1358)	38154 P6029
3.18 (0.1252)	38154 P6020	3.48 (0.1370)	38154 P6030
3.21 (0.1264)	38154 P6021	3.51 (0.1382)	38154 P6031
3.24 (0.1276)	38154 P6022	3.54 (0.1394)	38154 P6032
3.27 (0.1287)	38154 P6023	3.57 (0.1406)	38154 P6033
3.30 (0.1299)	38154 P6024	3.60 (0.1417)	38154 P6034
3.33 (0.1311)	38154 P6025	3.63 (0.1429)	38154 P6035
3.36 (0.1323)	38154 P6026	3.66 (0.1441)	38154 P6036

Drive pinion bearing preload N-m (kg-m, ft-lb) 1.1 - 1.7 (0.11 - 0.17, 0.8 - 1.2)

Drive pinion preload adjusting washer spacer R200 (mechanical LSD)

Thickness mm (in)	Part number	Thickness mm (in)	Part number
45.6 (1.795)	38165 10V05	46.5 (1.831)	38165 10V00
45.9 (1.807)	38165 10V06	46.8 (1.843)	38165 10V01
46.2 (1.819)	38165 10V07		

Drive pinion preload adjusting washer R200 (mechanical LSD)

Thickness mm (in)	Part number	Thickness mm (in)	Part number
3.81 (0.1500)	38125 61001	3.97 (0.1563)	38133 61001
3.83 (0.1508)	38126 61001	3.99 (0.1571)	38134 61001
3.85 (0.1516)	38127 61001	4.01 (0.1579)	38135 61001
3.87 (0.1524)	38128 61001	4.03 (0.1587)	38136 61001
3.89 (0.1531)	38129 61001	4.05 (0.1594)	38137 61001
3.91 (0.1539)	38130 61001	4.07 (0.1602)	38138 61001
3.93 (0.1547)	38131 61001	4.09 (0.1610)	38139 61001
3.95 (0.1555)	38132 61001		

LSD friction plate

Thickness mm (in)	Part number
1.75 (0.0689)	38432 N9000
1.85 (0.0728)	38432 N9001

NOTE: Pinion bearing preload and total preload refer to values measured when oil seals are install.

C5 FINAL DRIVE

2. On-vehicle Inspection and Preparation

(1) Front final drive (F160)

[Point 1] Oil leak inspection

- Replace oil seal with unit in vehicle if oil leaks from seal.

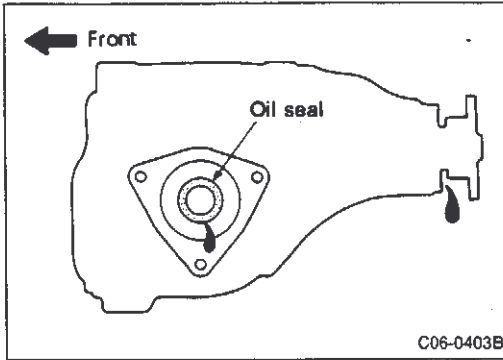

[Point 2] Oil level inspection

- Check oil level from filler plug hole.
- Use recommended Nissan gear oil hypoid GL-5 85W-90.

CAUTION:

When installing filler plug and drain plug, apply silicon bond TB1215 (KP210 00200) to thread surface. Tighten to following tightening torque.

Tightening torque:

25 - 34 N·m (2.5 - 3.5 kg-m, 18 - 25 ft-lb)

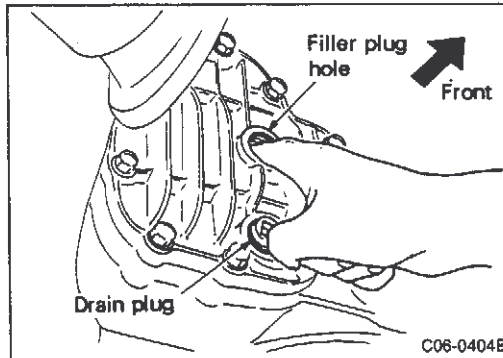

[Point 3] Rear oil seal replacement

- Use flange wrench (special tool) to remove drive pinion nut.

CAUTION:

Replace drive pinion nut after every disassembly.

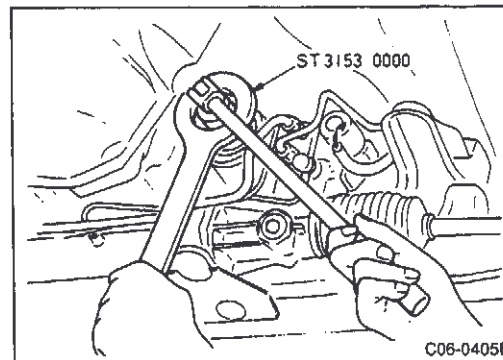

- Remove companion flange using puller.
- Check companion flange seal surface for wear and replace if worn.

CAUTION:

Do not repair companion flange with sandpaper or use again.

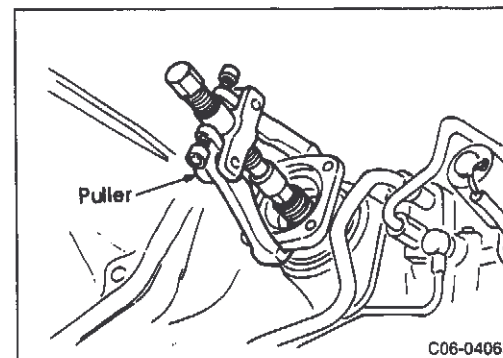

- Use screwdriver to remove oil seal.

CAUTION:

Never reuse oil seal.

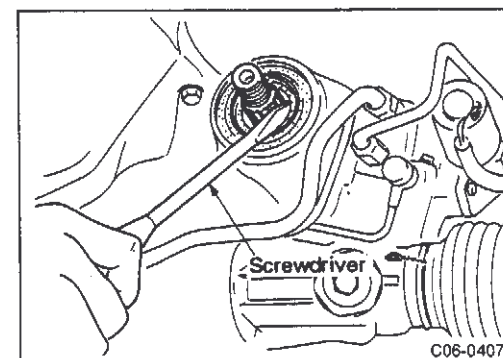

C5 FINAL DRIVE

2. On-vehicle Inspection and Preparation (Cont'd)

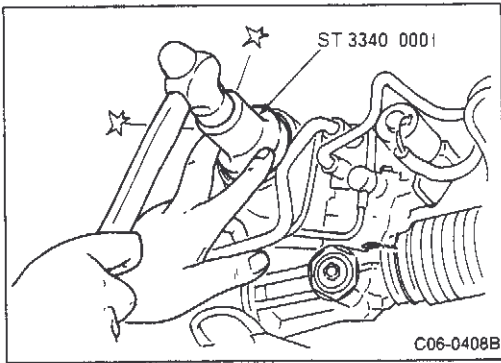

- Use suitable drift (special service tool) and install seal in position shown in figure.

CAUTION:

- (1) Do not install the oil seal at an angle.
- (2) Coat the sliding surface of the oil seal lip with MP special grease No. 2.

A: 2.0 ± 0.2 mm (0.079 ± 0.008 in)

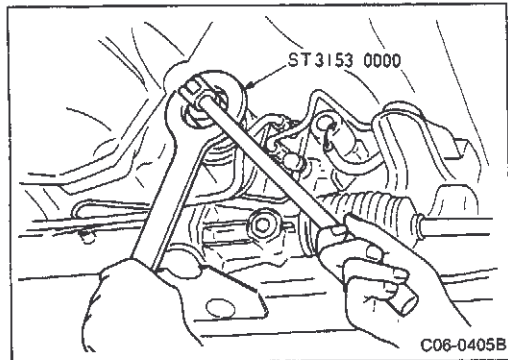
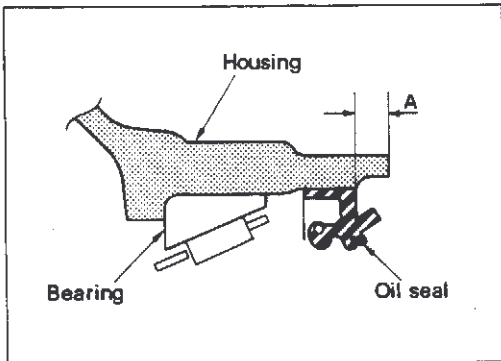

- Use flange wrench (special service tool) to tighten drive pinion nut to specified torque.

Tightening torque:

167 - 196 N·m (17 - 20 kg-m, 123 - 145 ft-lb)

CAUTION:

Always use new drive pinion nut. Coat nut screws and seat with Nissan gear oil hypoid GL-5 85W-90.

[Point 4] Side oil seal replacement

Ⓐ Right oil seal

- Remove oil seal using oil seal puller (special service tool).

CAUTION:

Never reuse the oil seal.

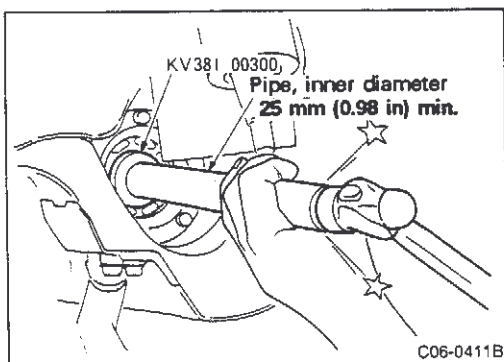
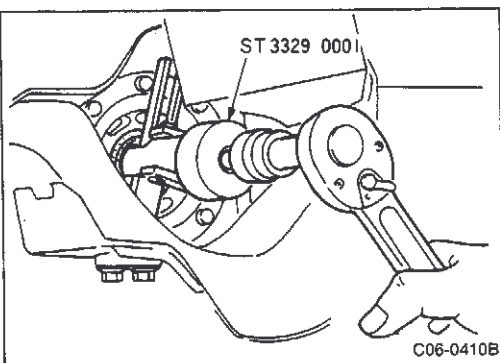

- Insert drift (special service tool) on pipe with 25 mm (0.98 in) inner diameter on lip and press seal flush with case.

CAUTION:

- (1) Do not install seal at angle.
- (2) Coat sliding lip surface of oil seal with MP special grease No. 2.

C5 FINAL DRIVE

2. On-vehicle Inspection and Preparation (Cont'd)

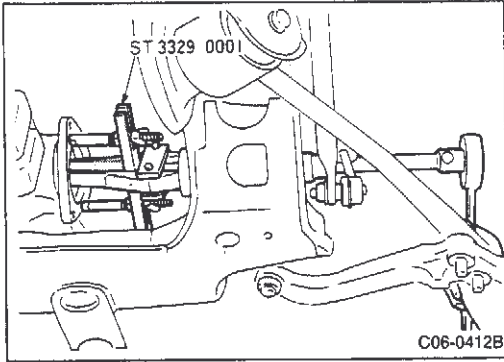

(b) Left oil seal

- Use oil seal puller (special service tool) to remove drive shaft (refer to C6 DRIVE SHAFT, 3 Drive Shaft Removal and Installation) and side shaft.

CAUTION:

Never reuse oil seal.

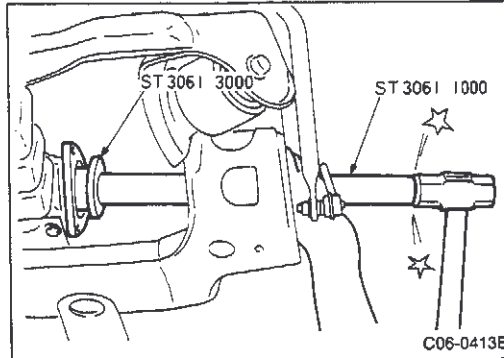

- Use drift (special service tool) and install oil seal flush with case.

CAUTION:

(1) Do not install seal at angle.

(2) Coat sliding lip surface of oil seal with MP special grease No. 2.

[Point 5] Side shaft end play inspection

- Turn side shaft two or three times. Check for abnormal noise or improper rotation and then measure end play.
- Set dial gauge on side shaft and move in axial direction to measure end play. If end play exceeds standard value adjust with shims. Refer to 3-2 (2) Front final drive side shaft assembly and disassembly.

End play standard value:

0 - 0.1 mm (0.004 in)

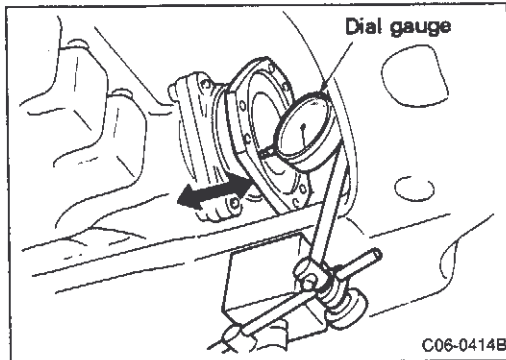

(2) Rear final drive [R200 (Mechanical LSD)]

[Point 1] Oil leak inspection

- When there is leak from oil seal, replace without removing final drive from vehicle.
- When there is leak from gasket, remove differential assembly from vehicle and replace gasket.

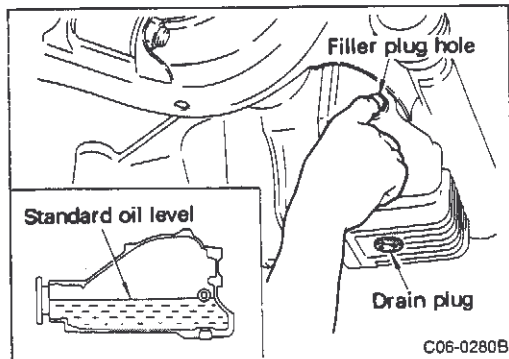
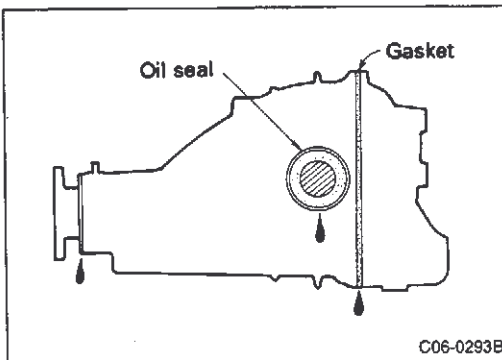

[Point 2] Oil level inspection

- Check oil level from filler plug hole.

C5 FINAL DRIVE

2. On-vehicle Inspection and Preparation (Cont'd)

[Point 3] Front oil seal replacement

- Before oil seal replacement, measure drive pinion total preload.
- Use cam sprocket wrench (special service tool) to remove drive pinion nut.

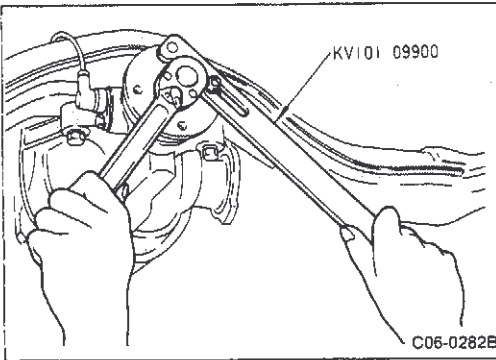

- Use puller to remove companion flange.

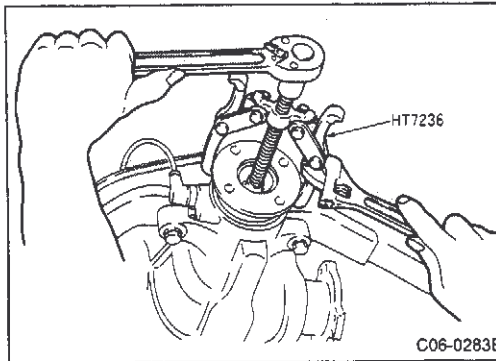

- Use oil seal puller (special service tool) to remove oil seal from gear carrier housing.

CAUTION:

Remove rear wheel speed sensor before removing oil seal.

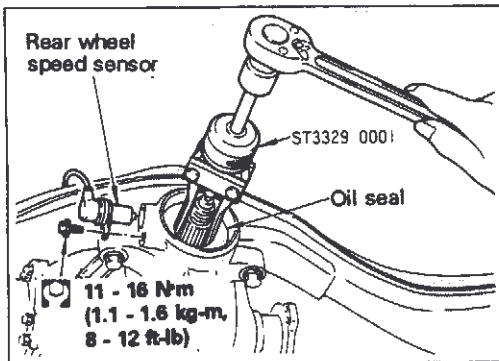

- Install oil seal using drift (special service tool).

CAUTION:

- (1) Do not install seal at angle.
- (2) Coat sliding surface of oil seal lip with MP special grease No. 2.

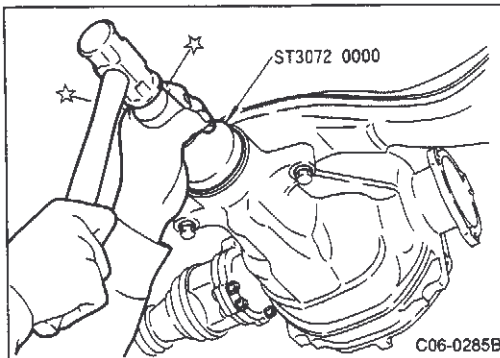

- Tighten drive pinion to torque indicated below.

Drive pinion tightening torque:

186 - 294 N·m (19 - 30 kg-m, 137 - 217 ft-lb)

- Adjust drive pinion total preload to same value before oil seal replacement.

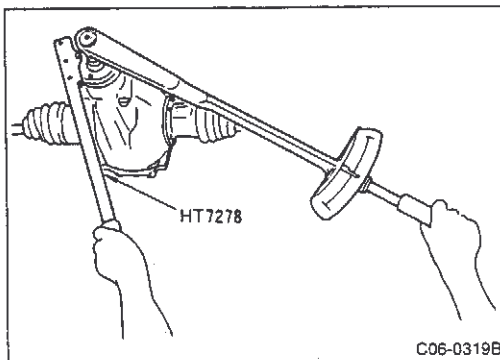

C5 FINAL DRIVE

2. On-vehicle Inspection and Preparation (Cont'd)

[Point 4] Side flange oil seal replacement

- Remove drive shaft (refer to C6 DRIVE SHAFT, 3 Drive Shaft Removal and Installation). Insert lug nut wrench into notch as lever and remove circlip.
- Circlip removal value

R200 (right & left)

Final drive side

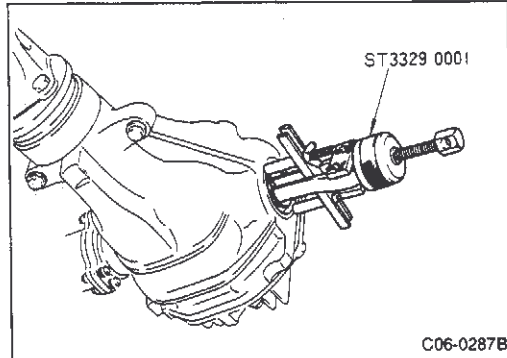
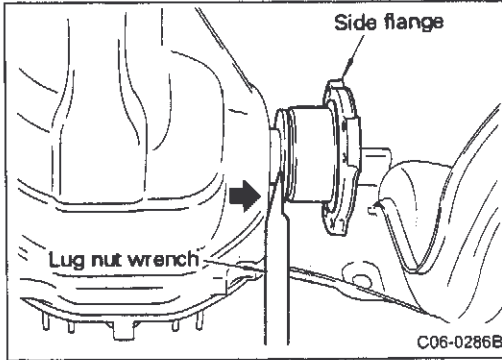

- Use oil seal puller (special service tool) to remove oil seal.

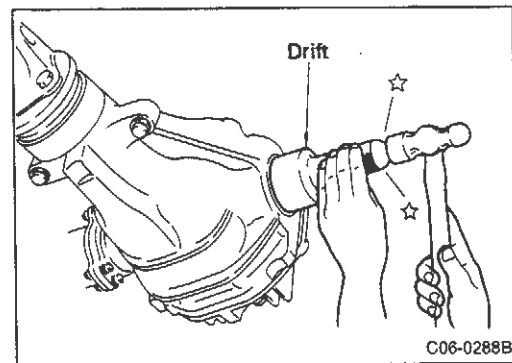

- Use drift (inner diameter 42.5 mm (1.673 in) , outer diameter 70 mm (2.76 in) to install oil seal.

CAUTION:

- (1) Do not install seal at angle.
- (2) Coat sliding surface of oil seal lip with MP special grease No. 2.

C5 FINAL DRIVE

3. Final Drive Removal and Installation, Assembly and Disassembly

3-1 REMOVAL AND INSTALLATION FROM VEHICLE

(1) Front final drive (F160)

① F160 final drive removal and installation

Remove and install front final drive (F160), engine and oil pan as a single unit (refer to section B oil pan removal and installation).

② Side shaft removal and installation

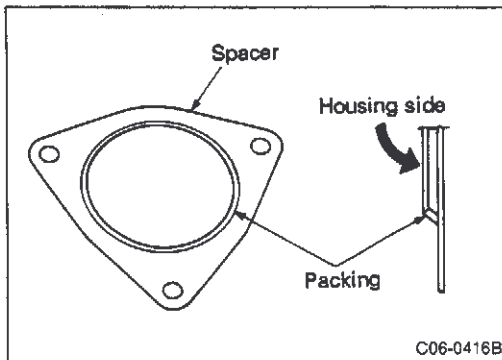
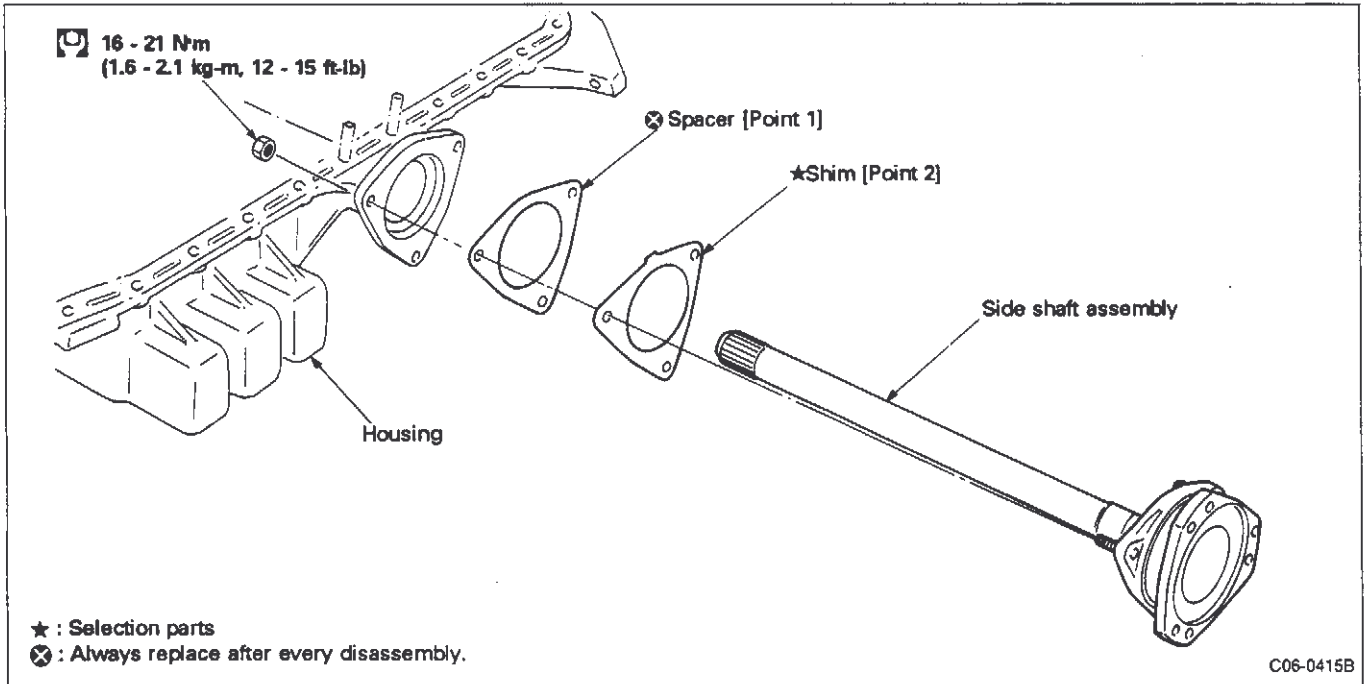

[Point 1] Spacer installation

- Install spacer so packing side faces final drive housing side.

CAUTION:
Never reuse spacer.

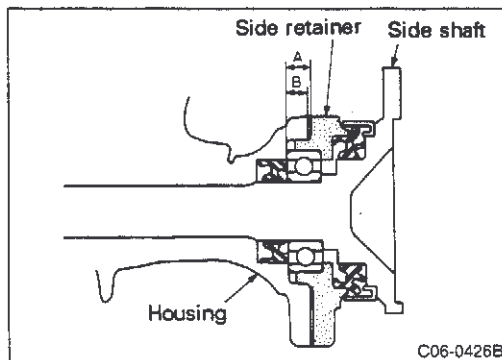

[Point 2] Side shaft bearing end play measurement

- Measure dimensions A and B shown in figure to calculate side shaft bearing end play.

C5 FINAL DRIVE

3. Final Drive Removal and Installation, Assembly and Disassembly (Cont'd)

- Measure dimension A as shown in figure.

CAUTION:

Measure bearing on outer race side.

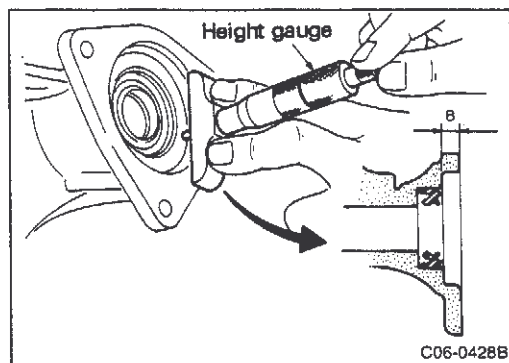
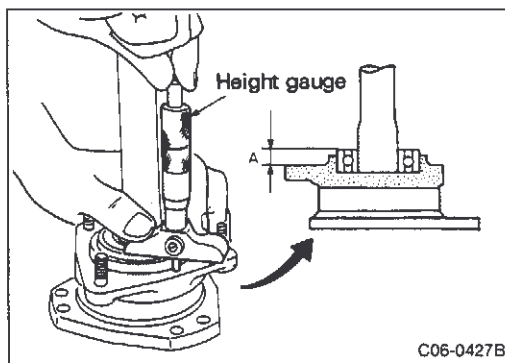

- Measure dimension B as shown in figure.

Side shaft bearing adjusting shim selection

- Use the following equation to calculate shim size required to obtain standard end play value.

End play:

0 - 0.1 mm (0 - 0.004 in)

$$T \text{ (shim thickness)} = A - B$$

Adjustment Shims

Thickness mm (in)	Part number
0.1 (0.004)	38233 03V01
0.2 (0.008)	38233 03V02
0.3 (0.012)	38233 03V03
0.4 (0.016)	38233 03V04
0.5 (0.020)	38233 03V05

Side shaft end play inspection

- Install side shaft in vehicle and check end play. Refer to 2-5 SIDE SHAFT END PLAY INSPECTION for procedures.

C5 FINAL DRIVE

3. Final Drive Removal and Installation, Assembly and Disassembly (Cont'd)

(2) Rear final drive [R200 (mechanical LSD)]

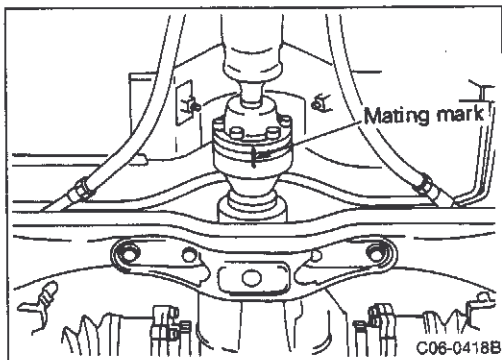
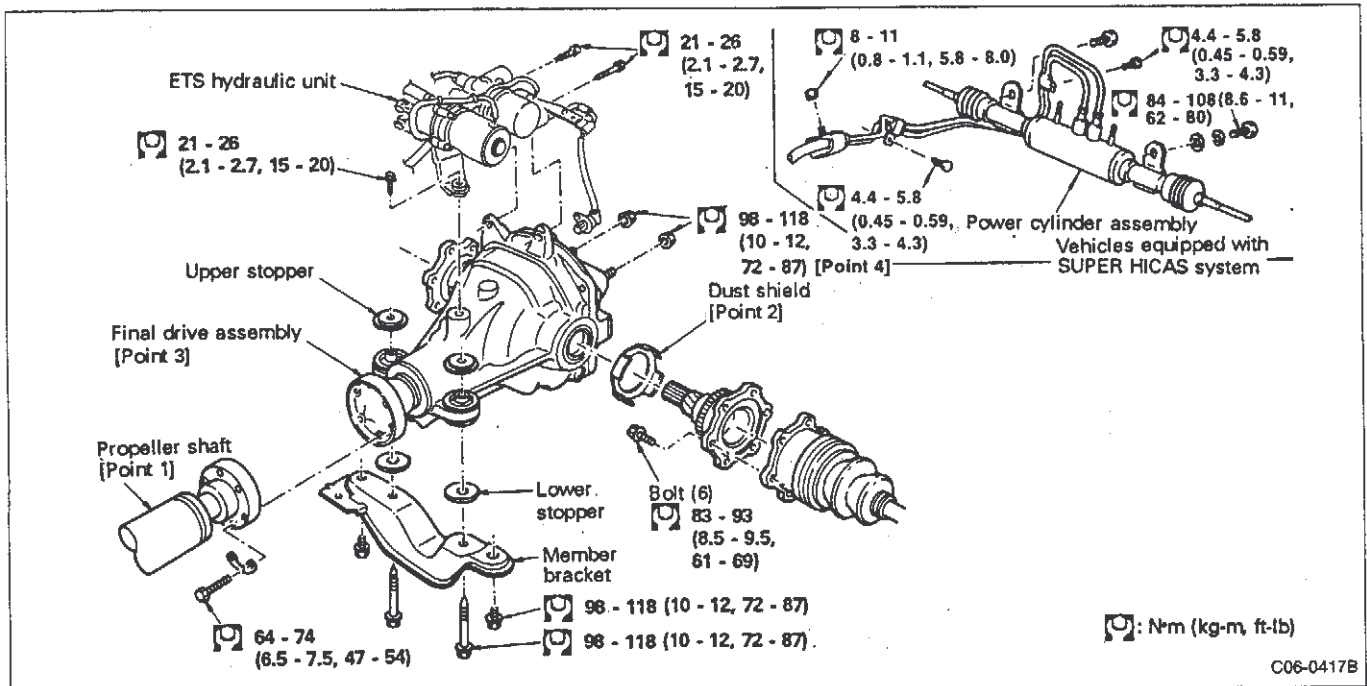

[Point 1] Propeller shaft and drive shaft separation

- Paint mating mark on companion flange before separating propeller shaft and final drive.
- Remove bolt from drive shaft and side flange and separate them.

CAUTION:

Use paint to make mating marks. Do not scratch the parts.

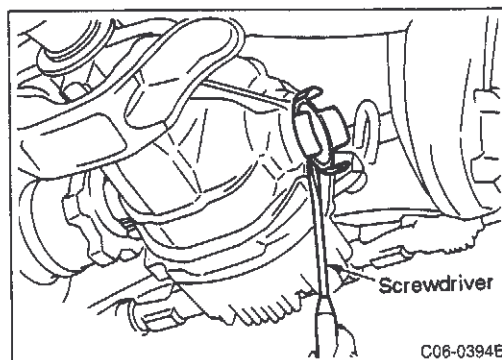

[Point 2] Dust shield removal and installation

Removal

- Use screwdriver to remove dust shield as shown in figure.

C5 FINAL DRIVE

3. Final Drive Removal and Installation, Assembly and Disassembly (Cont'd)

Installation

- Install dust shield with drift [inner diameter 85 mm (3.35 in), outer diameter 67 mm (2.64 in)].

CAUTION:

Align notch with sensor before installation.

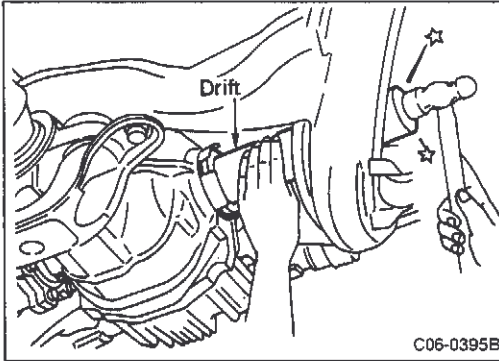

[Point 3] Differential mount insulator removal and installation

Removal

- Remove insulator with drift [outer diameter 32 mm (1.26 in), inner diameter 26 mm (1.02 in)] as shown in figure.

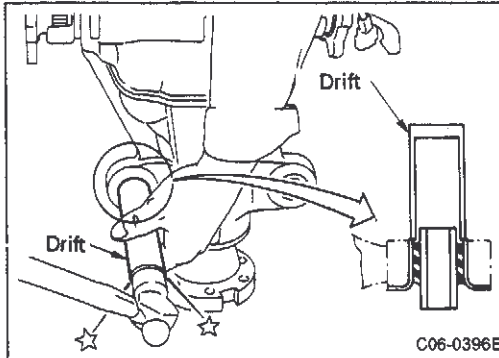

Installation

- Install insulator with drift [outer diameter 50 mm (1.97 in), inner diameter 25 mm (0.98 in)] as shown in figure.

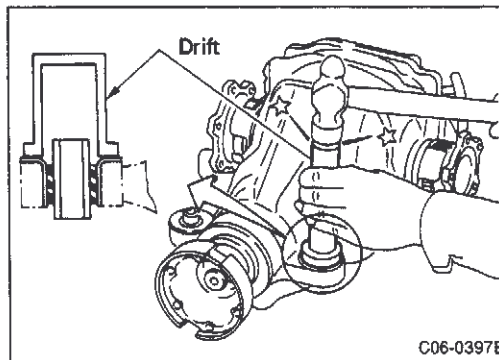

[Point 4] Final drive removal and installation

- In vehicles equipped with SUPER HICAS, perform the following procedures because the the nut ① on rear side of final drive interferes with power cylinder air bleeder.

Removal

- Remove final drive and member nuts ① (3), then remove HICAS piping member bolts ② (2) and nut ③ (1). Next, remove power cylinder bolts ④ (2).

CAUTION:

Do not remove power cylinder piping.

- Lower power cylinder piping, remove remaining final drive nut ① and detach final drive.

CAUTION:

Always support final drive with transmission jack during removal and installation.

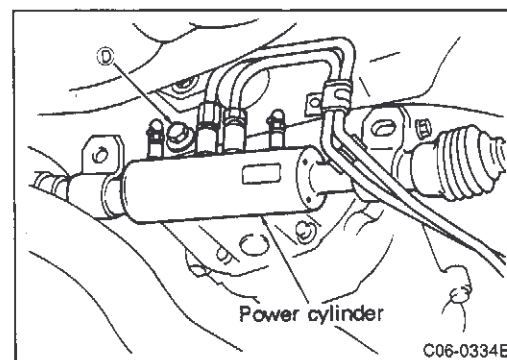
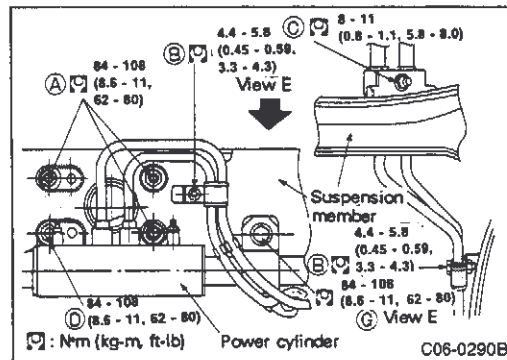

C5 FINAL DRIVE

3. Final Drive Removal and Installation, Assembly and Disassembly (Cont'd)

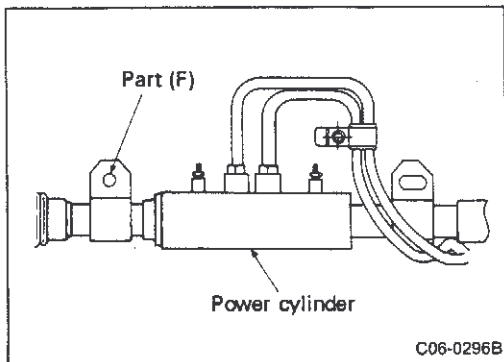

Installation

- Assembly is the reverse of disassembly.

CAUTION:

Pay attention to following points when installing power cylinder.

- (1) Part (F) on the left side of power cylinder determines position. Install part (F) first and then install power cylinder.

Power cylinder bolt tightening torque:

84 - 108 N·m (8.6 - 11 kg·m, 62 - 80 ft·lb)

- (2) Install nut (C) for piping first.
- (3) After installing nut, make sure rear suspension toe-in distance conforms to specification range indicated below. If toe-in distance does not conform, make adjustment. Refer to C8 REAR SUSPENSION AND AXLE, 2-4 WHEEL ALIGNMENT INSPECTION AND ADJUSTMENT for adjustment procedures.

Standard distance:

$2.0^{+2.0}_{-2.5}$ mm ($0.079^{+0.079}_{-0.098}$ in)

3-2 FINAL DRIVE ASSEMBLY AND DISASSEMBLY

(1) Front final drive (F160)

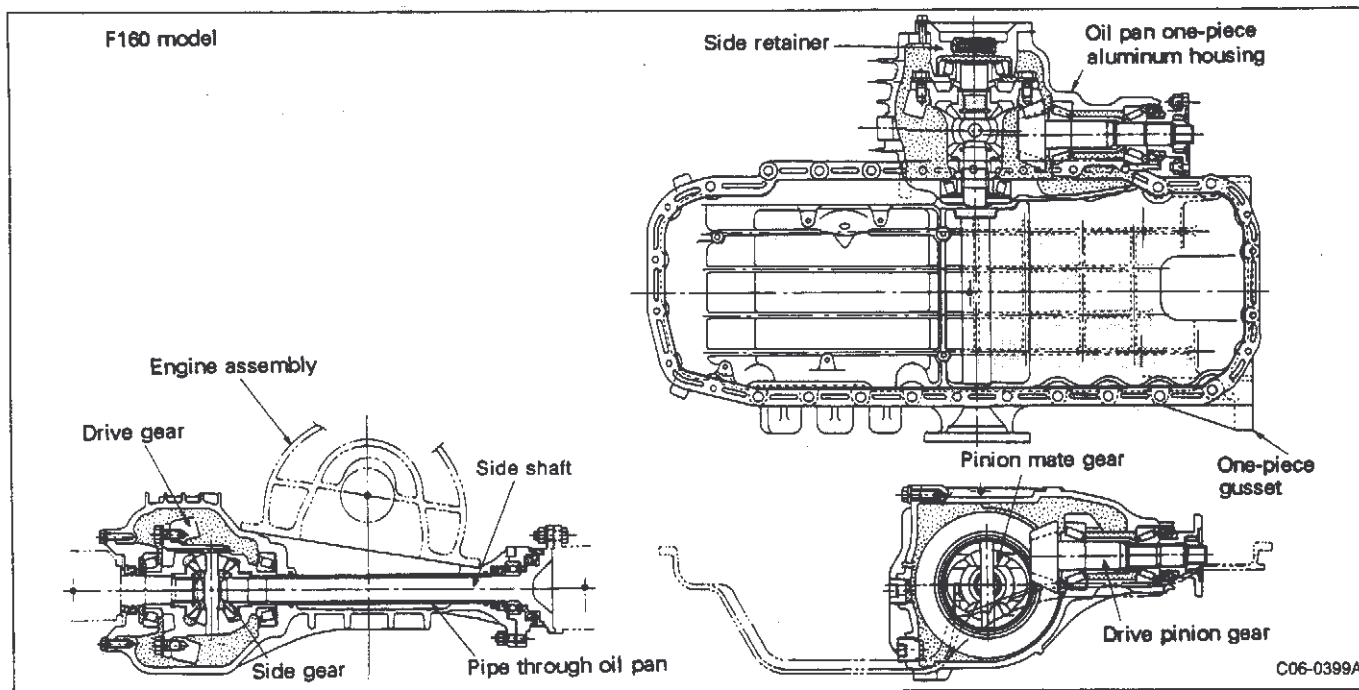

C5 FINAL DRIVE

3. Final Drive Removal and Installation, Assembly and Disassembly (Cont'd)

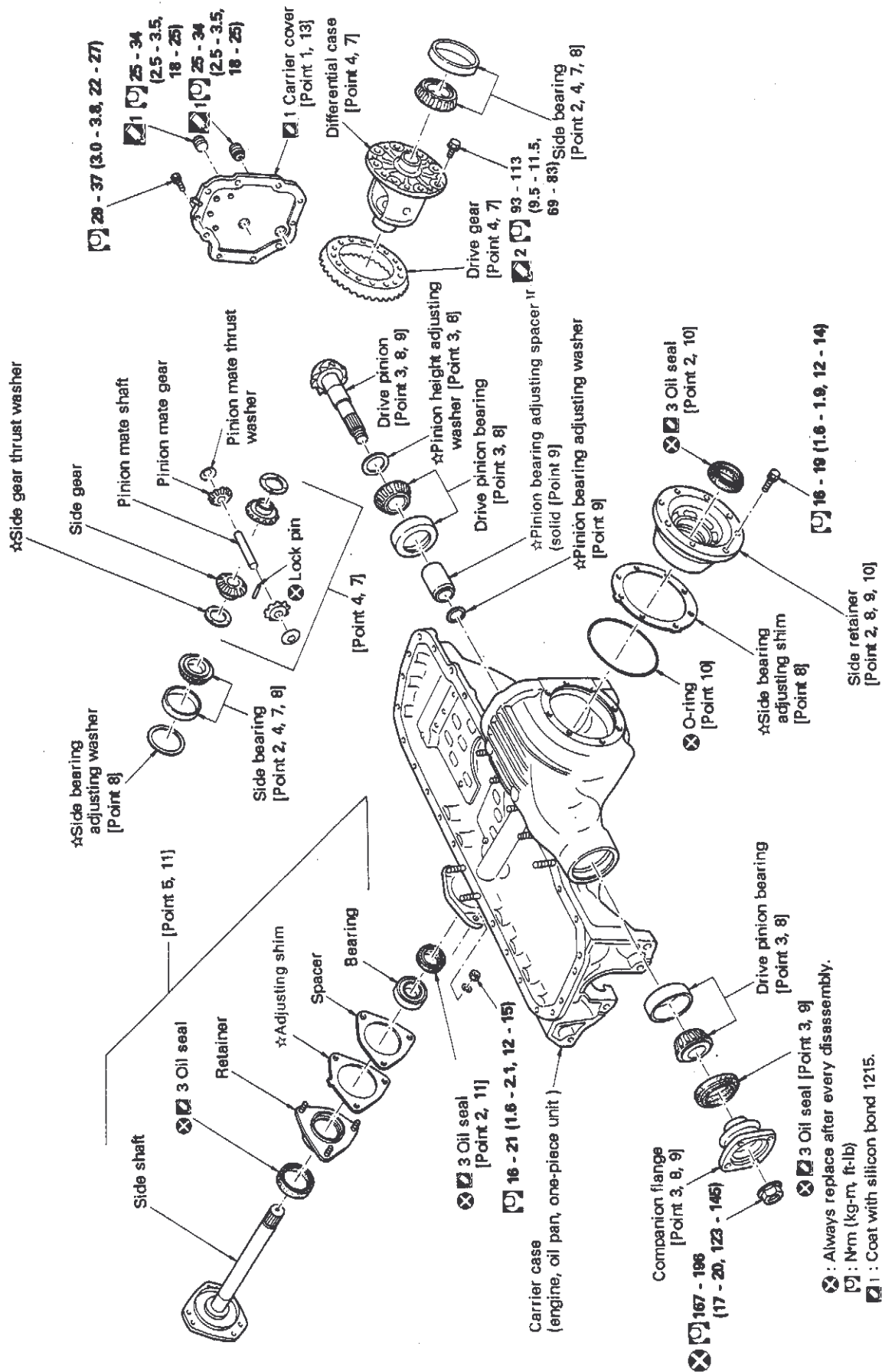

- ⊗ : Always replace after every disassembly.
- [] : N/m (kg-m, ft-lb)
- 1 : Coat with silicon bond 1215.
- 2 : Seal with Loctite.
- ☆ : Selection part
- 3 : Coat with Nissan MP special grease No. 2.

C5 FINAL DRIVE

3. Final Drive Removal and Installation, Assembly and Disassembly (Cont'd)

[Point 1] Inspection before disassembly

- Drain oil.
- Remove carrier cover.

CAUTION:

If carrier case is worn or cracked, replace unit assembly.

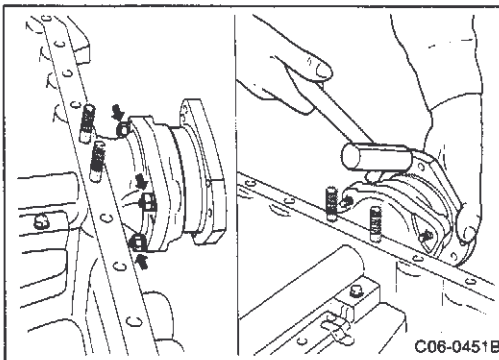
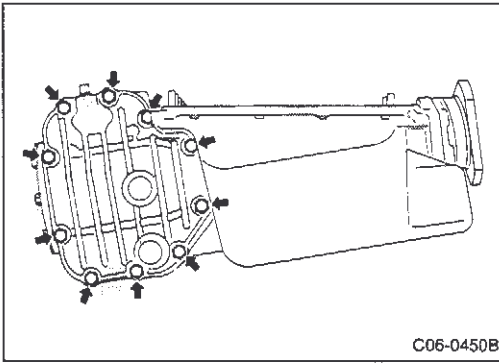

- Remove side shaft assembly nut.
- While tapping with plastic hammer, remove side shaft assembly from carrier case.

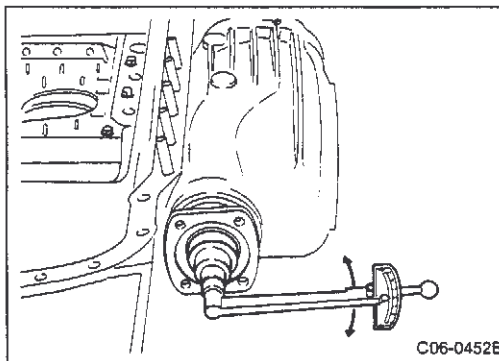

a) Total preload inspection

- Turn companion flange a few times. Use preload gauge to measure total preload.

Total preload standard:

1.6 - 2.2 N·m (0.16 - 0.22 kg-m, 1.2 - 1.6 ft-lb)

- If torque preload is not within the specification range, adjust pinion bearing preload and side bearing preload.

Excess preload:	<ul style="list-style-type: none"> ● Use lower drive pinion spacer and thinner washer. ● Use thicker side bearing retainer shim.
Insufficient preload:	<ul style="list-style-type: none"> ● Use longer drive pinion spacer and thicker washer. ● Use thinner side bearing retainer shim.

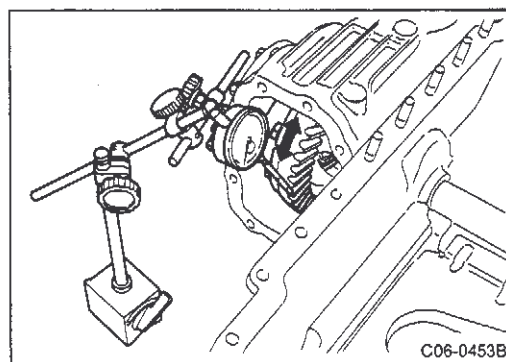

b) Hypoid gear and backlash inspection

- Position dial gauge on drive gear surface and measure backlash.

Backlash standard value:

0.13 - 0.18 mm (0.0051 - 0.0071 in)

- If backlash is not within the specification range, adjust by increasing or decreasing side bearing washer (carrier case side) thickness.

C5 FINAL DRIVE

3. Final Drive Removal and Installation, Assembly and Disassembly (Cont'd)

Excess backlash:	Use thinner side bearing washer (carrier case side).
Insufficient backlash:	Use thicker side bearing washer (carrier case side).

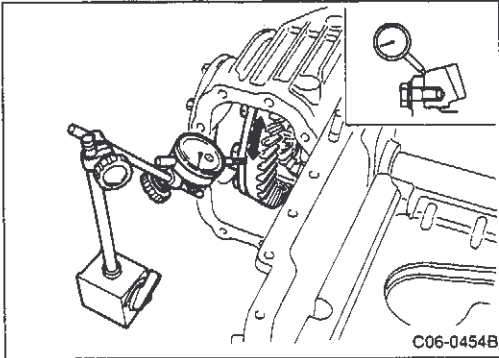

Ⓒ Drive gear runout inspection

- Position dial gauge on drive gear rear surface. Turn drive gear a few times and measure runout.

Runout limit:

0.05 mm (0.0020 in) max.

- If runout is not within the specification range, check drive gear contact condition (foreign matter between drive gear and differential case, differential case or drive gear deformation, etc.).
- If drive gear is worn or deformed, replace hypoid gear assembly. If there is differential case deformation, replace case.

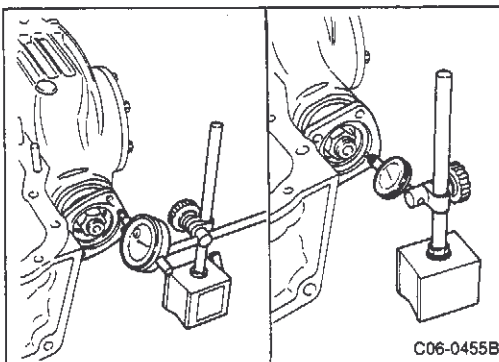

Ⓓ Companion flange runout inspection

- Position dial gauge on companion flange surface (inside propeller shaft surface bolt holes) and measure runout.

Runout limit:

0.05 mm (0.0020 in) max.

- Set test indicator inside companion flange (inner lower surface) and measure runout.

Runout limit:

0.05 mm (0.0020 in) max.

CAUTION:

If surface is rusted, remove rust before measuring surface.

- If runout is not within the specification range, rotate positions of both companion flange and drive pinion 90° to minimize runout.
- If runout is still not within the specification range even after rotating relative positions of flange and drive pinion, replace companion flange.
- If runout is still not within the specification range even after replacing companion flange, the pinion bearing and drive pinion gear tooth contact pattern may be incorrect or the pinion bearing may be faulty.

C5 FINAL DRIVE

3. Final Drive Removal and Installation, Assembly and Disassembly (Cont'd)

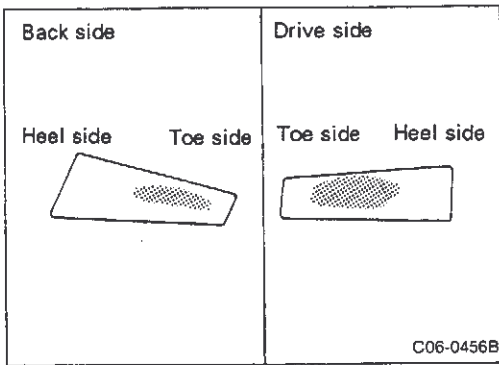

Ⓔ Hypoid gear mesh inspection

- Apply a light coat of powdered titanium oxide and oil or equivalent to drive gear teeth. Rotate gear slowly in both directions a few times and check gear tooth contact pattern.
- Check gear contact pattern on both drive side (acceleration) and back side (deceleration).

CAUTION:

Refer to h. Hypoid gear tooth contact inspection for details on applying powdered titanium oxide and gear tooth contact inspection.

- If gear tooth contact is faulty, increase or decrease height washer thickness to adjust position.

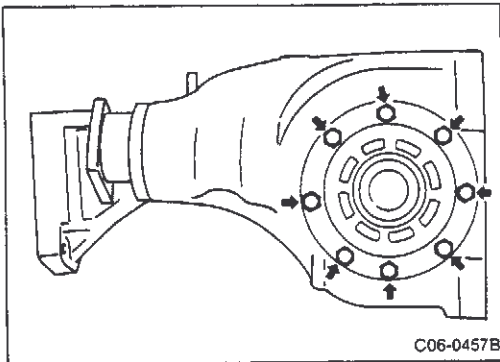

[Point 2] Drive gear and differential case assembly removal

- Remove side retainer bolts.

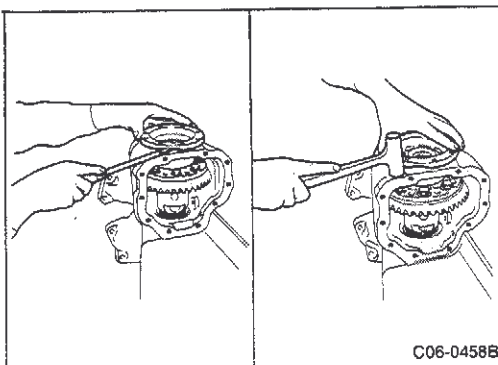

- Insert screwdriver in side retainer notch and raise retainer.
- While removing side retainer, tap gear case with plastic hammer and remove retainer.

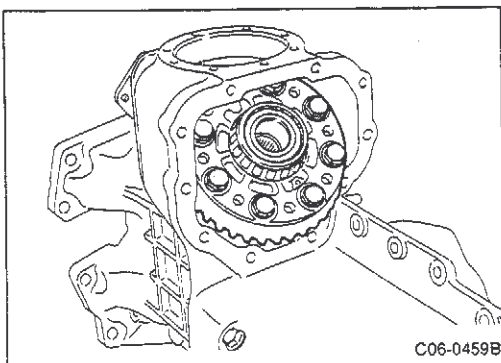

- Remove differential case assembly from carrier case.

CAUTION:

Be careful not to scratch carrier cover during removal.

C5 FINAL DRIVE

3. Final Drive Removal and Installation, Assembly and Disassembly (Cont'd)

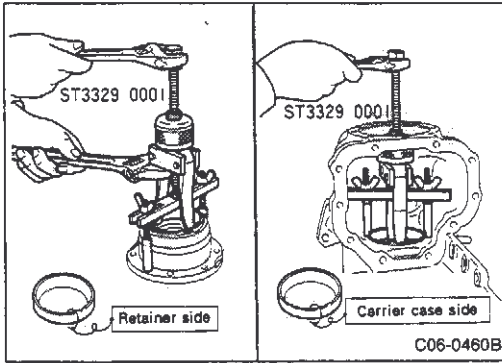

- Use puller (special service tool) and remove side bearing and outer race.

CAUTION:

Remove side bearing and adjusting washer together in carrier case side.

- Make an identification mark on outer race to prevent incorrect assembly of left and right sides.

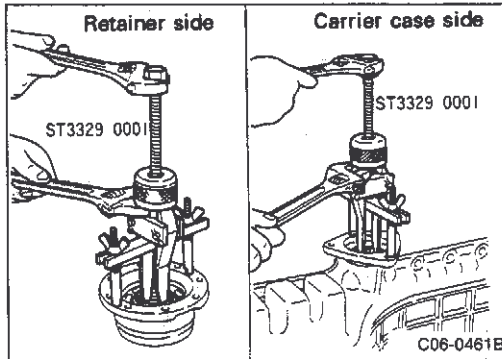

- Use puller (special service tool) to remove oil seal.

[Point 3] Drive pinion assembly removal

- Use flange wrench and remove pinion lock nut.

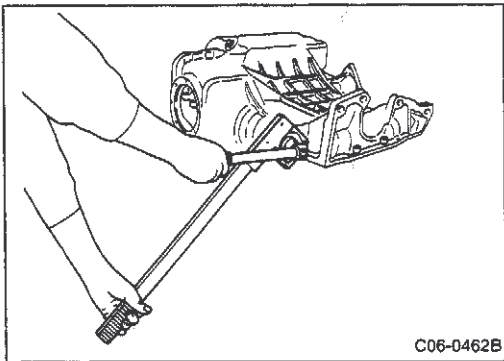

- Use puller to remove companion flange.

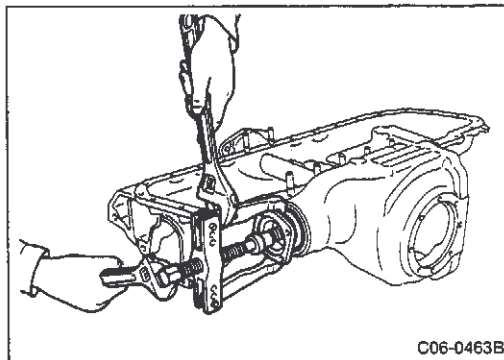

- Install pinion lock nut on drive pinion.

CAUTION:

Set pinion lock nut even on drive pinion to prevent damage to pinion threads.

- Using copper hammer, remove drive pinion from carrier case.

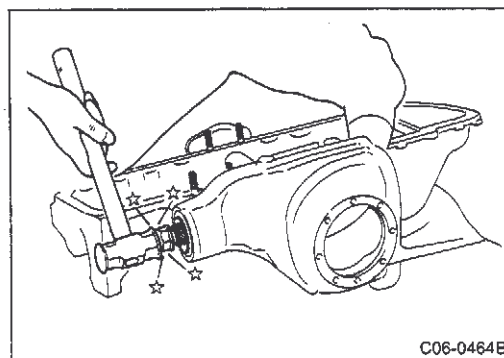

C5 FINAL DRIVE

3. Final Drive Removal and Installation, Assembly and Disassembly (Cont'd)

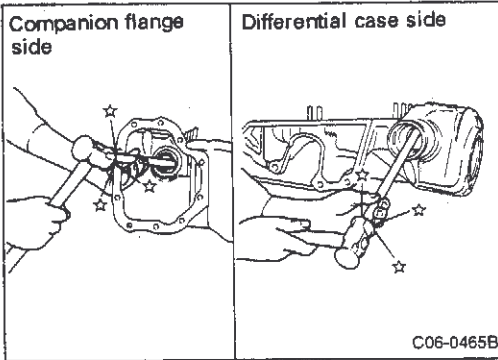

- Use a brass shaft and tap bearing outer race evenly to remove race from carrier case.
- Remove bearing and oil seal together in companion flange side.

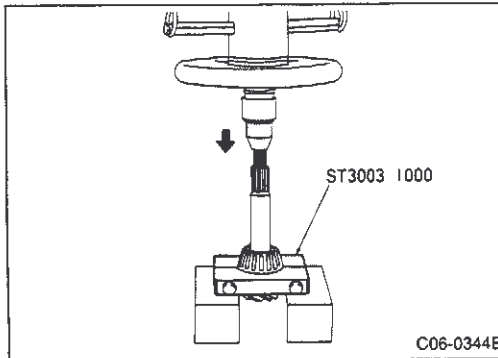

- Use bearing replacer (special service tool) and remove drive pinion and differential case side bearings.

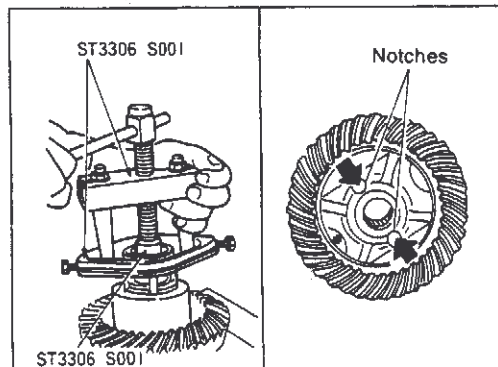

[Point 4] Differential case disassembly

(a) Side bearing removal

- Set differential case assembly in vise. Using puller set (special service tool), remove side bearing.

CAUTION:

- (1) When placing unit in vise, always use copper plates to prevent side bearing and drive gear from being scratched.
- (2) Do not remove side bearing except for replacement.

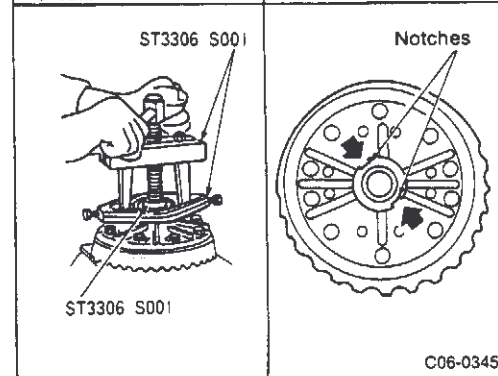

(b) Drive gear removal

- Remove differential case bolts.
- Tap side of drive gear with plastic hammer and remove drive gear.

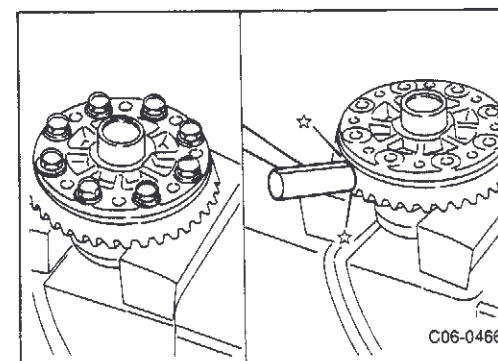

C5 FINAL DRIVE

3. Final Drive Removal and Installation, Assembly and Disassembly (Cont'd)

Ⓒ Side gear surface clearance inspection

- Clean thoroughly to prevent side gear, side gear thrust washer and differential case from being coated with gear oil.
- Position differential case upright to enable side gear measurement.

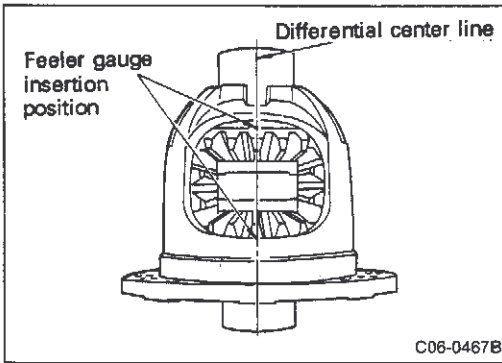

- Insert feeler gauges of same thickness from both sides in rear surface of side gear to prevent side gear from falling and then measure clearance.
- Rotate side gear, measure clearance in three locations and calculate average value.

Side gear rear clearance:

0.15 mm (0.0059 in) max. (Gear must rotate without resistance.)

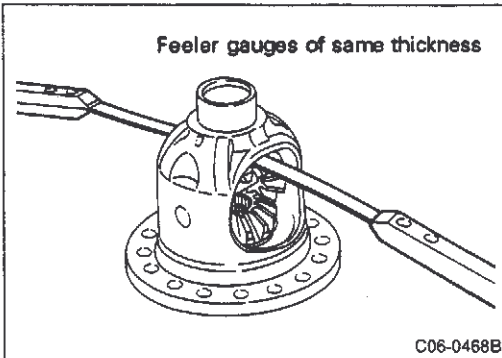

- Turn differential case upside down and measure side gear clearance on opposite side in same manner.

Side gear rear clearance:

0.15 mm (0.0059 in) max. (Gear must rotate without resistance.)

If side gear clearance is not within specification, select proper thrust washer thickness to adjust clearance.

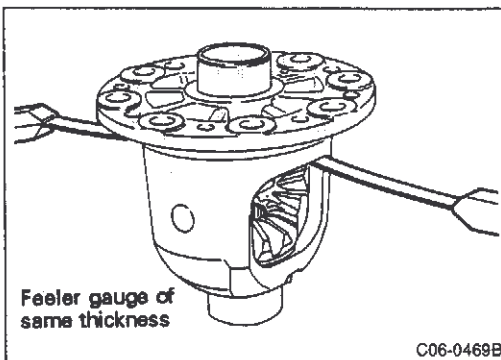

Excess rear clearance:	Use thicker thrust washer.
Insufficient rear clearance:	Use thinner thrust washer.

Ⓓ Disassembly

- Use pin punch (special service tool) to remove pinion mate shaft lock pin.

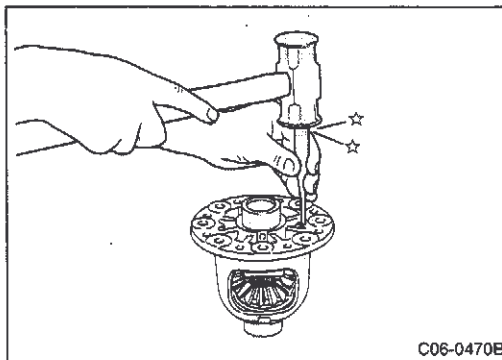

- Remove pinion mate shaft.

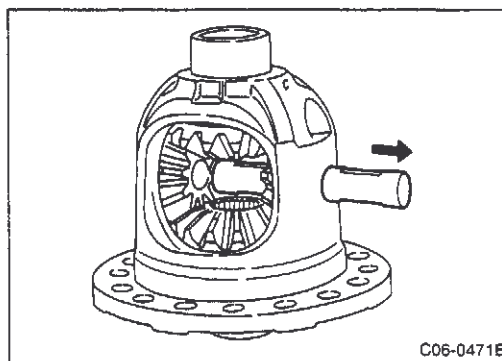

C5 FINAL DRIVE

3. Final Drive Removal and Installation, Assembly and Disassembly (Cont'd)

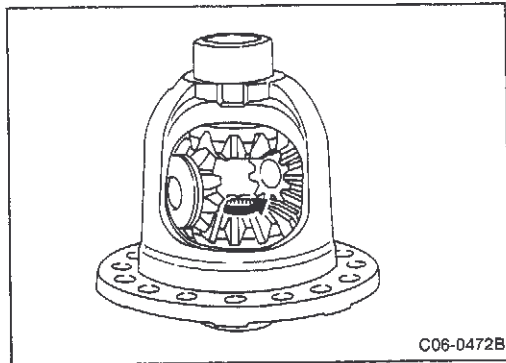

- Rotate pinion mate gear. Remove pinion mate gear and pinion mate thrust washer, side gear and side gear thrust washer from differential case.

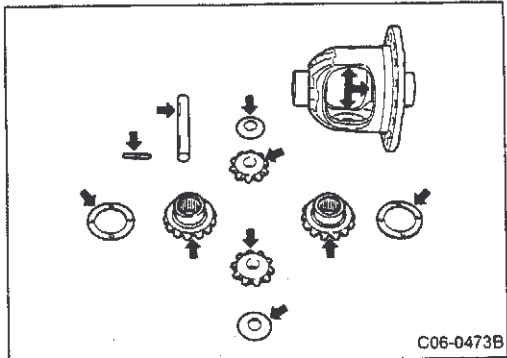

- Refer to [Point 6] (described later) for inspection procedures of side gear, side gear thrust washer, pinion mate shaft, pinion mate gear, pinion mate thrust washer and differential case.

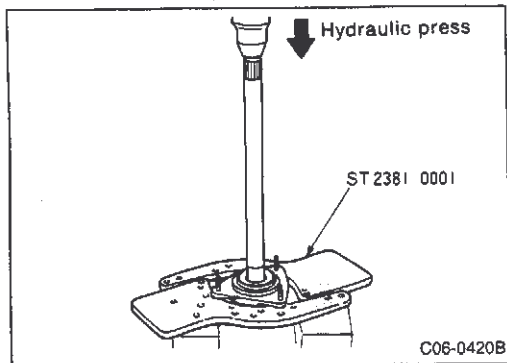

[Point 5] Side shaft assembly disassembly

- Use hydraulic press and remove side shaft from retainer.

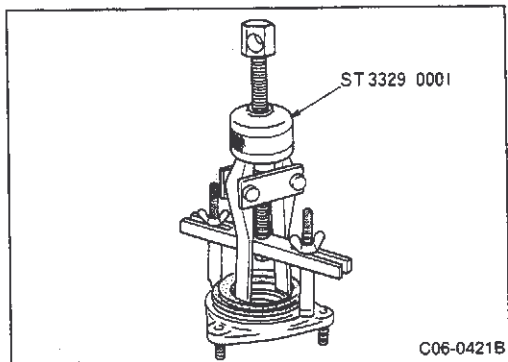

- Use hydraulic puller (special service tool) and remove oil seal from retainer.

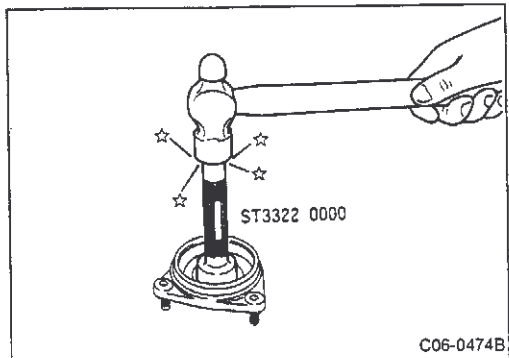

- Use drift (special service tool) and remove bearing from retainer.

C5 FINAL DRIVE

3. Final Drive Removal and Installation, Assembly and Disassembly (Cont'd)

- Clean disassembled parts in suitable solvent and blow dry with compressed air. Repair or replace worn or scratched parts as follows.

Item	Processing
Side shaft	● Replace oil seal if seal lip contact surface is worn [approx. 0.1 mm (0.004 in)] or exhibits heat deformation.
Retainer	● Replace if worn, scratched or cracked.
Bearing	● Rotate bearing by hand and check for wear, scratches, pitting or flaking. Replace bearing if noisy or damaged or rotation is not smooth.
Oil seal	● Always replace with new seal after removal. Replace if there is lip wear, fatigue, damage or other problem.

[Point 6] Part inspection

- Clean disassembled parts in suitable solvent and blow dry with compressed air. Check for wear, scratches or other damage and replace as indicated below.

Item	Processing
Hypoid gear	<ul style="list-style-type: none"> ● Check cause of abnormal gear tooth contact and correct during assembly. ● If wear is excessive, replace gears which cannot be adjusted as sets. ● If gears are cracked, scratched or damaged replace as set.
Bearing	● Check for wear, scratches, pitting, rust or flaking. Rotate bearing by hand and replace as necessary.
Side gear and pinion mate gear	<ul style="list-style-type: none"> ● Check for wear, scratches, or other damage on gear surface and replace as necessary. ● Check for wear, seizing of thrust washer and replace as necessary.
Side gear and pinion mate gear thrust washer	● Check for wear, seizing, scratches, or other damage and replace as necessary.
Oil seal	● Always replace with new seal after removal. Replace if there is lip wear, fatigue or other problem.
Differential case	● Replace case if sliding parts are cracked or worn.
Companion flange	● Replace seal if seal lip contact surface is worn [approx. 0.1 mm (0.004 in)] or exhibits fatigue.

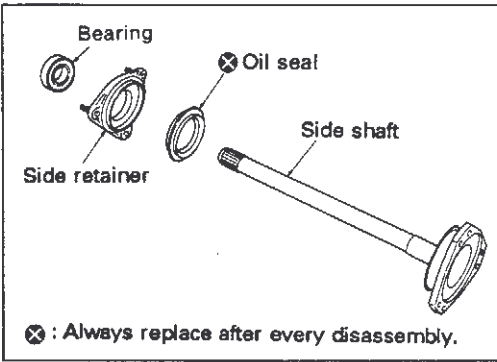

[Point 7] Differential case assembly

- Assemble thrust washer in side gear.

Note:

Make sure thrust washer used in assembly is same washer or thickness as disassembled washer.

- Coat sliding parts of differential case, gears and thrust washer with gear oil.
- Assemble side gear and thrust washer, pinion mate gear and thrust washer in differential case.

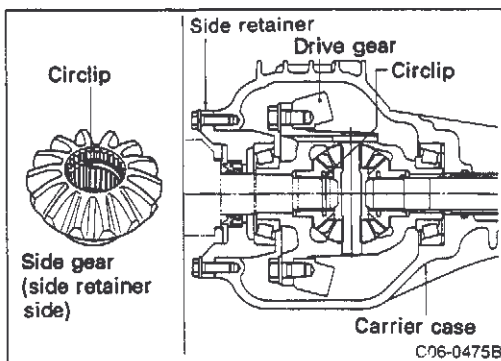

C5 FINAL DRIVE

3. Final Drive Removal and Installation, Assembly and Disassembly (Cont'd)

CAUTION:

Assemble side gear with circlip in side retainer side.

- Align two pinion mate gears in diagonal position. Rotate gears and install in differential case.

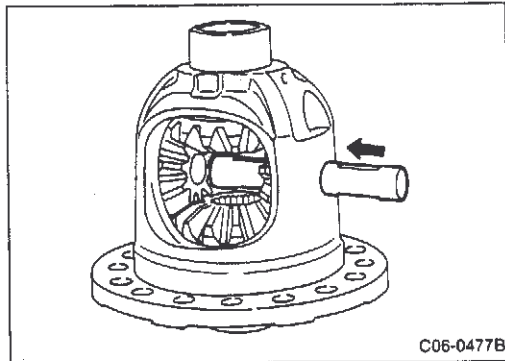
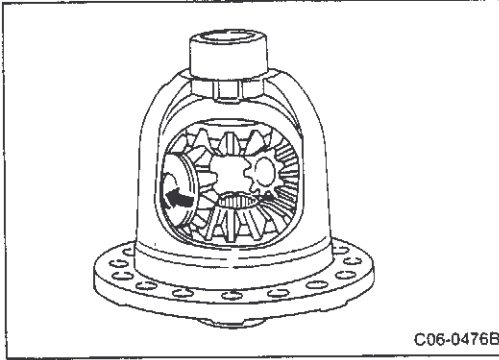

- Align differential case lock pin hole and shaft lock pin hole and assemble pinion mate shaft.

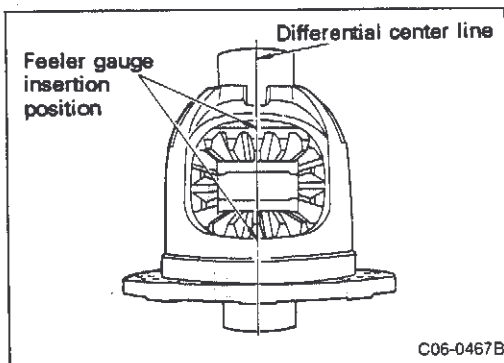

- Place differential case so side gear to be measured faces up.

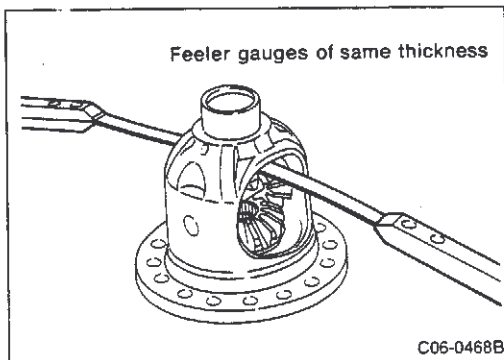

- Insert feeler gauges of same thickness from both sides in rear surface of side gear to prevent side gear from falling and then measure clearance.
- Rotate side gear, measure clearance in three locations and calculate average value.
- Select side gear thrust washer so clearance is within specification shown below.

Side gear rear clearance:

0.15 mm (0.0059 in) max. (Gear must rotate without resistance.)

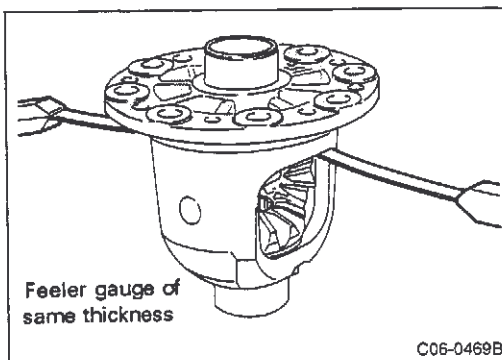

- Turn differential case upside down and measure side gear clearance on opposite side in same manner.
- If rear clearance is not within specification, select proper thrust washer thickness to adjust clearance.

Excess rear clearance:	Use thicker thrust washer.
Insufficient rear clearance:	Use thinner thrust washer.

C5 FINAL DRIVE

3. Final Drive Removal and Installation, Assembly and Disassembly (Cont'd)

Side gear thrust washers

Thickness mm (in)	Part number	Thickness mm (in)	Part number	Thickness mm (in)	Part number
0.68 - 0.71 (0.0268 - 0.0280)	38424 W1010	0.80 - 0.83 (0.0315 - 0.0327)	38424 W1014	0.92 - 0.95 (0.0362 - 0.0374)	38424 W1018
0.71 - 0.74 (0.0280 - 0.0291)	38424 W1011	0.83 - 0.86 (0.0327 - 0.0339)	38424 W1015	0.95 - 0.98 (0.0374 - 0.0386)	38424 W1019
0.74 - 0.77 (0.0291 - 0.0303)	38424 W1012	0.86 - 0.89 (0.0339 - 0.0350)	38424 W1016	0.98 - 1.01 (0.0386 - 0.0398)	38424 W1020
0.77 - 0.80 (0.0303 - 0.0315)	38424 W1013	0.89 - 0.92 (0.0350 - 0.0362)	38424 W1017	1.01 - 1.04 (0.0398 - 0.0409)	38424 W1021

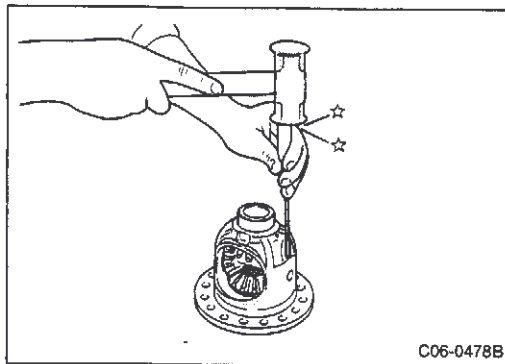

- Use pin punch (special service tool) to insert lock pin in pinion mate shaft.

CAUTION:

Always replace lock pin with new part after every disassembly.

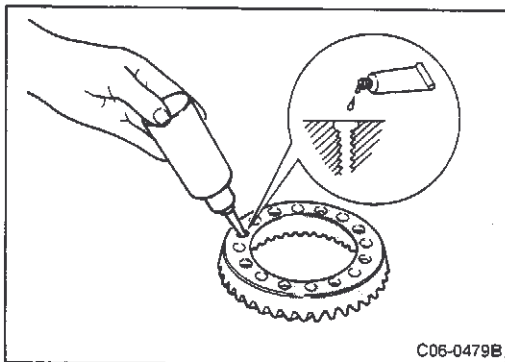

- Coat drive gear threads with one or two drops of Loctite.

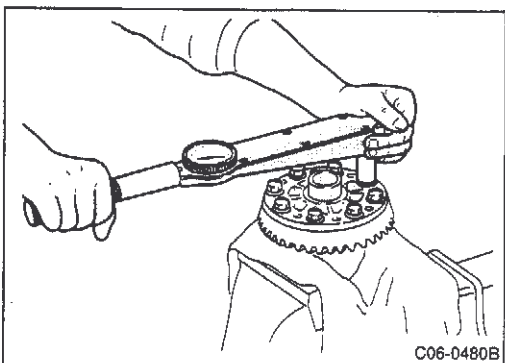

- Install drive gear in differential case.
- Coat bolt seat with rust preventative oil and tighten bolts evenly in criss-cross sequence.

Tightening torque:

93 - 113 N·m (9.5 - 11.5 kg-m, 69 - 83 ft-lb)

C5 FINAL DRIVE

3. Final Drive Removal and Installation, Assembly and Disassembly (Cont'd)

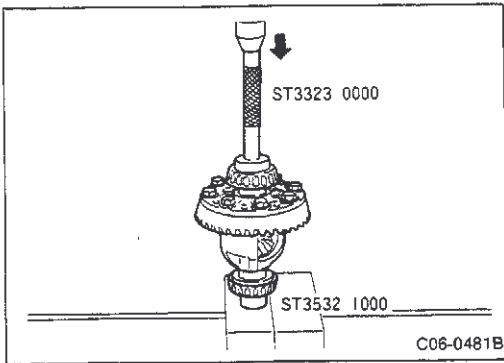

- Use drift (special service tool) and press-fit side bearing in differential case.

CAUTION:

Use hammer to start bearing installation. Set differential case and bearing in vertical position and press-fit bearing.

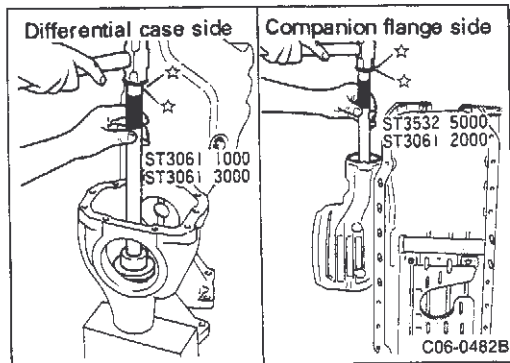

[Point 8] Hypoid gear contact and backlash inspection

a) Pinion bearing outer race installation

- Use drift (special service tool) to install pinion bearing outer race in carrier case.

CAUTION:

Press-fit outer race straight into carrier case and not at an angle.

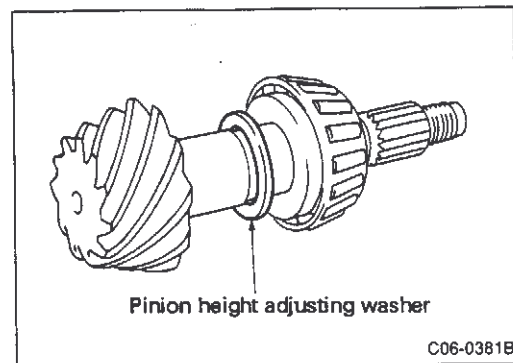

b) Pinion height adjusting washer installation (temporary installation)

- Assemble height adjusting washer on drive pinion.

CAUTION:

Make sure height adjusting washer used for assembly is same washer or same thickness as washer that was removed.

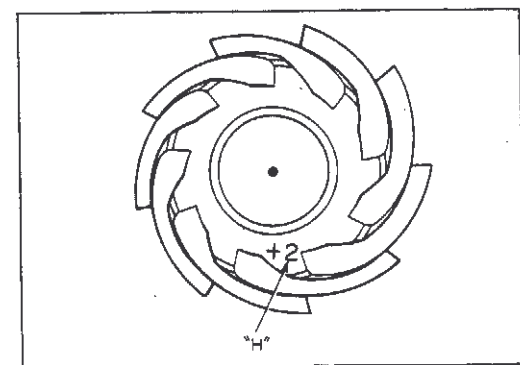

c) Gear set replacement washer selection

- When replacing hypoid gear set, calculate processing error correction value for new and former drive pinion and select suitable washer.

- Processing error correction

$$T = T_0 + (t_1 - t_2)$$

T: Thickness of washer to be installed

T₀: Thickness of removed washer

t₁: Former drive pinion head number

(Processing error is expressed in unit of 1/100 mm)

t₂: New drive pinion head number

(Processing error is expressed in unit of 1/100 mm)

Calculation example:

$$\text{If } T_0 = 3.21 \quad t_1 = +2 \quad t_2 = -1$$

$$\text{Then: } T = 3.21 + [(2 \times 0.01) - (-1 \times 0.01)] = 3.24$$

- Install washer temporarily on drive pinion.

Pinion height adjusting washers

Thickness mm (in)	Part number	Thickness mm (in)	Part number
3.09 (0.1217)	38154 U1500	3.39 (0.1335)	38154 U1510
3.12 (0.1228)	38154 U1501	3.42 (0.1346)	38154 U1511
3.15 (0.1240)	38154 U1502	3.45 (0.1358)	38154 U1512
3.18 (0.1252)	38154 U1503	3.48 (0.1370)	38154 U1513
3.21 (0.1264)	38154 U1504	3.51 (0.1382)	38154 U1514
3.24 (0.1276)	38154 U1505	3.54 (0.1394)	38154 U1515
3.27 (0.1287)	38154 U1506	3.57 (0.1406)	38154 U1516
3.30 (0.1299)	38154 U1507	3.60 (0.1417)	38154 U1517
3.33 (0.1311)	38154 U1508	3.63 (0.1429)	38154 U1518
3.36 (0.1323)	38154 U1509	3.66 (0.1441)	38154 U1519

C5 FINAL DRIVE

3. Final Drive Removal and Installation, Assembly and Disassembly (Cont'd)

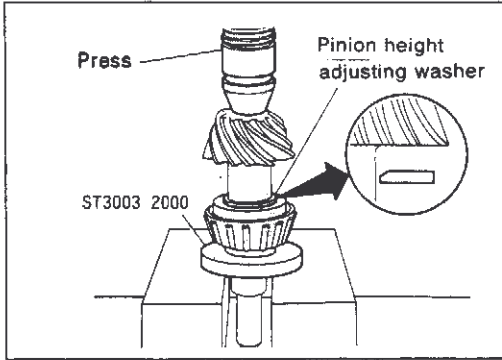

ⓓ Pinion bearing installation

- Use drift (special service tool) and install bearing.

CAUTION:

Make sure washer is facing correct direction.

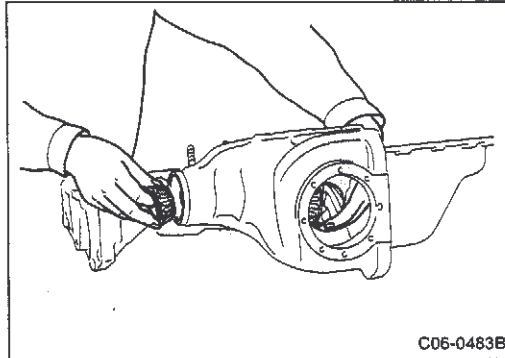

ⓔ Drive pinion and bearing installation

- Coat bearing with gear oil.
- Assemble drive pinion and bearing in carrier case without spacer and adjusting washer.

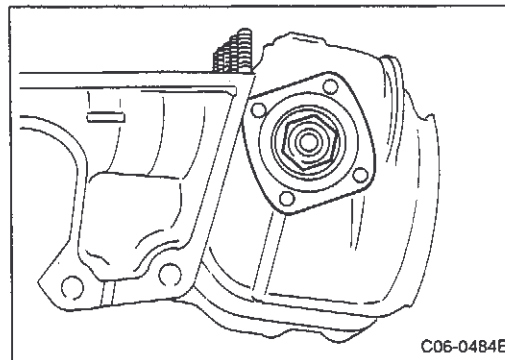

- Install companion flange without oil seal.
- Coat drive pinion threads and pinion nut seat with rust-preventative oil and install nut temporarily.

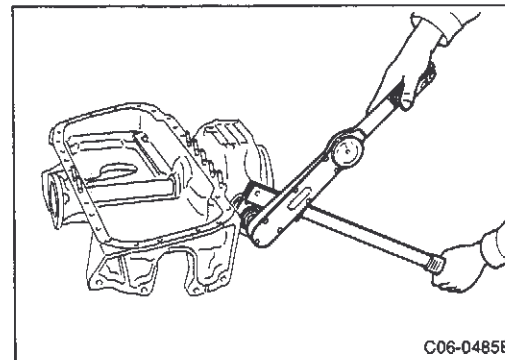

- Tighten pinion lock nut to specified preload torque.
Pinion bearing preload standard value (without oil seal installed):
0.7 - 1.0 N-m (0.07 - 0.10 kg-m, 0.5 - 0.7 ft-lb)

CAUTION:

Tighten pinion lock nut in 5° to 10° increments while preload is measured because spacer is not inserted. Do not tighten excessively.

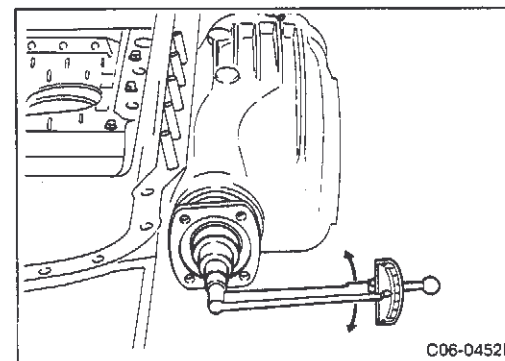

C5 FINAL DRIVE

3. Final Drive Removal and Installation, Assembly and Disassembly (Cont'd)

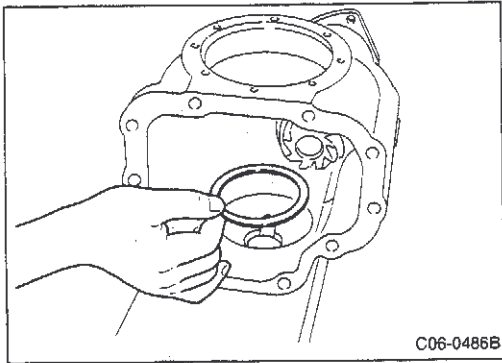

① Differential case installation

- Install side bearing adjusting washer (carrier case side) in carrier case.

CAUTION:

Make sure adjusting washer used for assembly is same washer or same thickness as washer that was removed. Otherwise, use washer indicated below.

Thickness mm (in)	Part number
2.00 (0.0787)	38453 03V01

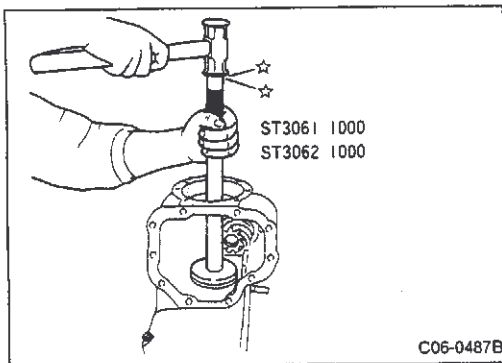

- Use drift (special service tool) and install side bearing outer race (carrier side) in differential case.

CAUTION:

Do not tap with excessive force.

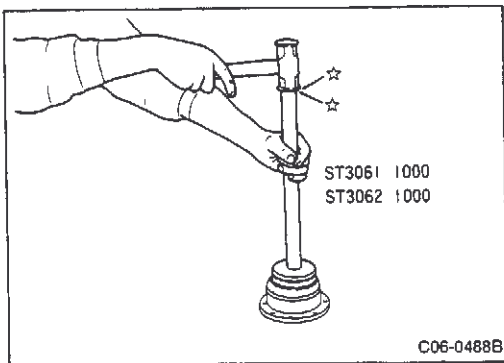

- Use drift (special service tool) and install side bearing outer race in side retainer.

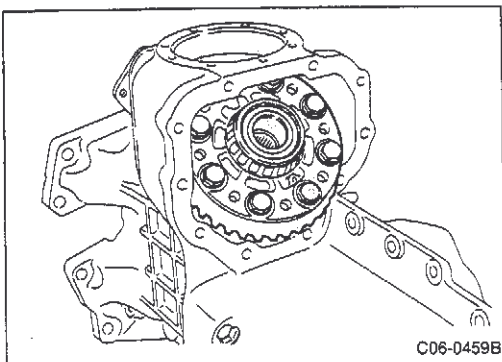

- Coat bearing with gear oil.
- Install differential case assembly in carrier case.

CAUTION:

Do not scratch carrier cover surface.

C5 FINAL DRIVE

3. Final Drive Removal and Installation, Assembly and Disassembly (Cont'd)

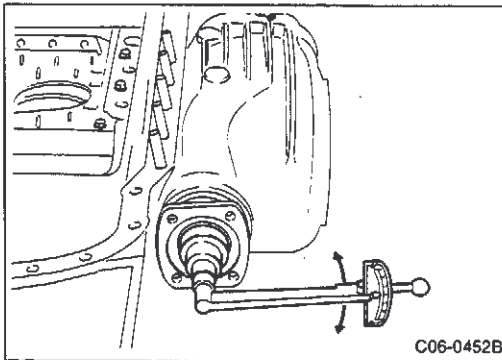
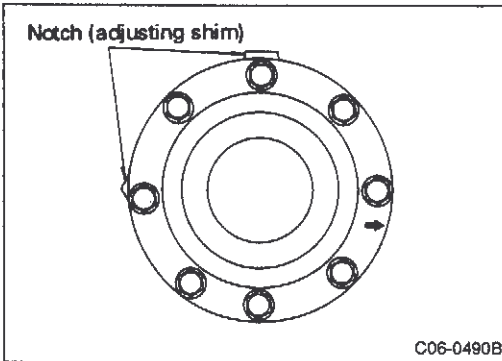
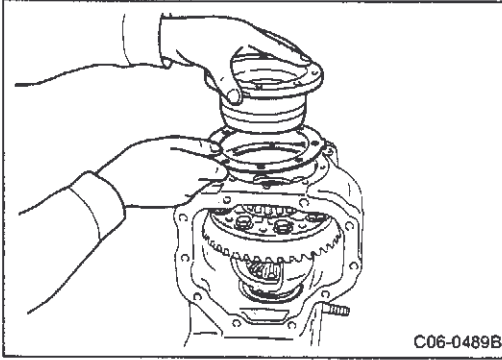

- Assemble side bearing adjusting shim in side retainer.

CAUTION:

Make sure adjusting shim used for assembly is same shim or same thickness as shim that was removed.

- Install side bearing adjusting shims so they face the two notches on top and rear of carrier case.
- Install side retainer in direction of arrow facing front of carrier case.

Tightening torque:

16 - 19 N·m (1.6 - 1.9 kg-m, 12 - 14 ft-lb)

CAUTION:

Do not install O-ring.

ⓐ **Total preload measurement**

- Rotate companion flange more than 20 times. Measure preload with preload gauge.

Total preload standard value

(without oil seal installed):

1.5 - 2.1 N·m (0.15 - 0.21 kg-m, 1.1 - 1.5 ft-lb)

- If preload torque is not within specification range, adjust by selecting suitable shim thickness for side retainer.

Excessive preload:	Use thicker shim.
Insufficient preload:	Use thinner shim.

Side bearing adjusting shim (side retainer side)

Thickness mm (in)	Part number	Thickness mm (in)	Part number	Thickness mm (in)	Part number
0.35 (0.0138)	38453 03V60	0.65 (0.0256)	38453 03V66	0.95 (0.0374)	38453 03V72
0.40 (0.0157)	38453 03V61	0.70 (0.0276)	38453 03V67	1.00 (0.0394)	38453 03V73
0.45 (0.0177)	38453 03V62	0.75 (0.0295)	38453 03V68	1.05 (0.0413)	38453 03V74
0.50 (0.0197)	38453 03V63	0.80 (0.0315)	38453 03V69	1.10 (0.0433)	38453 03V75
0.55 (0.0217)	38453 03V64	0.85 (0.0335)	38453 03V70	1.15 (0.0453)	38453 03V76
0.60 (0.0236)	38453 03V65	0.90 (0.0354)	38453 03V71		

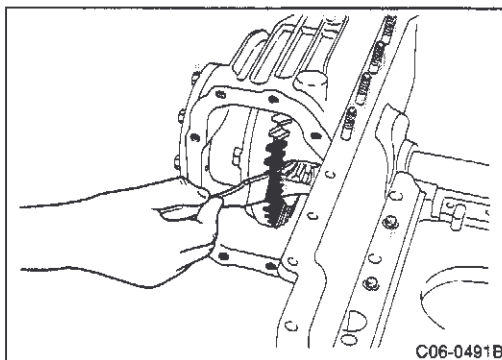

ⓑ **Gear tooth contact inspection**

- Coat both sides of drive gear tooth surface with titanium oxide. Rotate drive gear and drive pinion and check gear tooth contact pattern.

C5 FINAL DRIVE

3. Final Drive Removal and Installation, Assembly and Disassembly (Cont'd)

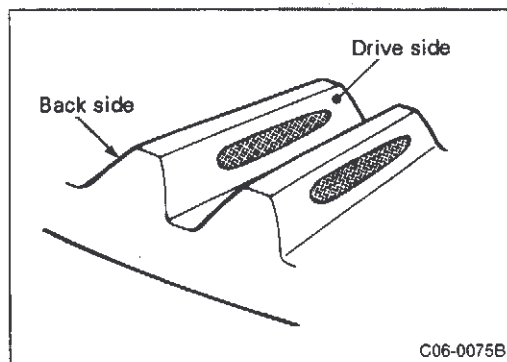

- Check drive gear tooth contact in four locations, on the drive side (acceleration side) and back side (deceleration).

Gear tooth contact pattern standard

Contact pattern		Pinion height adjusting washer selection value mm (in)	Adjustment
Back side	Drive side		
Toe contact Heel contact 	Heel contact Toe contact 	+0.15 (+0.0059)	Necessary
Toe contact Heel contact 	Heel contact Toe contact 	+0.12 (+0.0047)	↑
Toe contact Heel contact 	Heel contact Toe contact 	+0.09 (+0.0035)	↑
Toe contact Heel contact 	Heel contact Toe contact 	+0.06 (+0.0024)	Unnecessary
Toe contact Heel contact 	Heel contact Toe contact 	+0.03 (+0.0012)	↑
Toe contact Heel contact 	Heel contact Toe contact 	0 (0)	↑
Toe contact Heel contact 	Heel contact Toe contact 	-0.03 (-0.0012)	↑
Toe contact Heel contact 	Heel contact Toe contact 	-0.06 (-0.0024)	↑
Toe contact Heel contact 	Heel contact Toe contact 	-0.09 (-0.0035)	Necessary
Toe contact Heel contact 	Heel contact Toe contact 	-0.12 (-0.0047)	↑
Toe contact Heel contact 	Heel contact Toe contact 	-0.15 (-0.0059)	↑

C5 FINAL DRIVE

3. Final Drive Removal and Installation, Assembly and Disassembly (Cont'd)

① Tooth contact adjustment

- If tooth contact is not correct, change pinion height adjusting washer thickness to adjust pinion height [X mm (in) in figure].

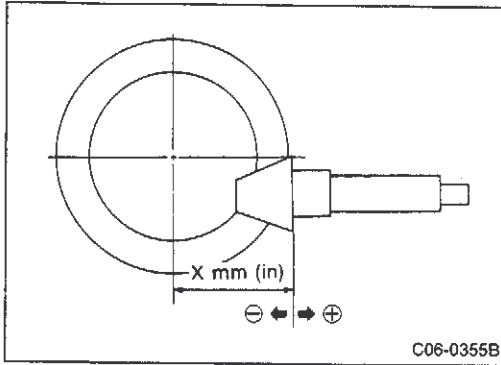

Pinion height adjusting washer

Thickness mm (in)	Part number	Thickness mm (in)	Part number	Thickness mm (in)	Part number
3.09 (0.1247)	38154 U1500	3.30 (0.1299)	38154 U1507	3.51 (0.1382)	38154 U1514
3.12 (0.1228)	38154 U1501	3.33 (0.1311)	38154 U1508	3.54 (0.1394)	38154 U1515
3.15 (0.1240)	38154 U1502	3.36 (0.1323)	38154 U1509	3.57 (0.1406)	38154 U1516
3.18 (0.1252)	38154 U1503	3.39 (0.1335)	38154 U1510	3.60 (0.1417)	38154 U1517
3.21 (0.1264)	38154 U1504	3.42 (0.1346)	38154 U1511	3.63 (0.1429)	38154 U1518
3.24 (0.1276)	38154 U1505	3.45 (0.1358)	38154 U1512	3.66 (0.1441)	38154 U1519
3.27 (0.1287)	38154 U1506	3.48 (0.1370)	38154 U1513		

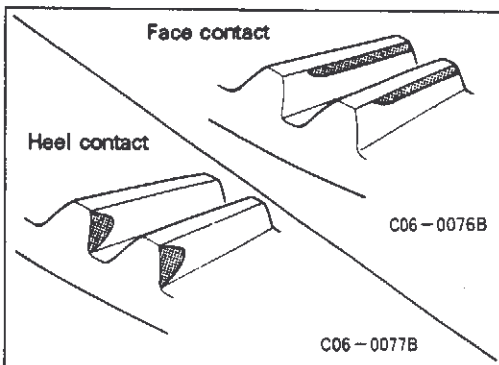

- If face contact or heel contact occur, increase pinion height adjusting washer thickness to move drive pinion closer to drive gear.

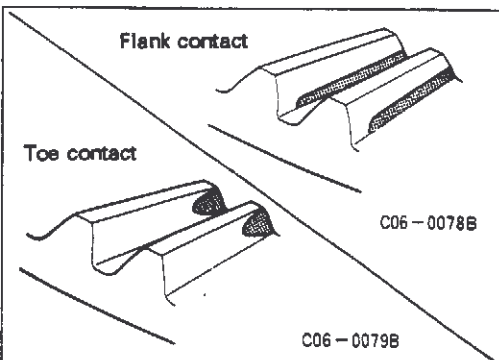
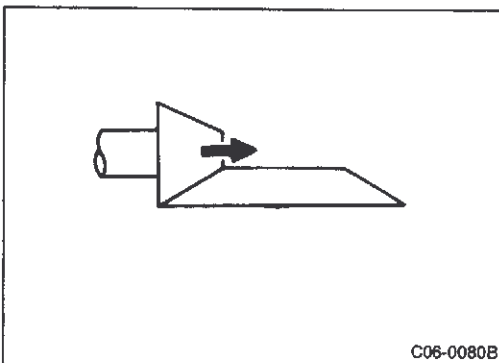

- If flank contact or toe contact occur, decrease pinion height adjusting washer thickness to move drive pinion away from drive gear.

C5 FINAL DRIVE

3. Final Drive Removal and Installation, Assembly and Disassembly (Cont'd)

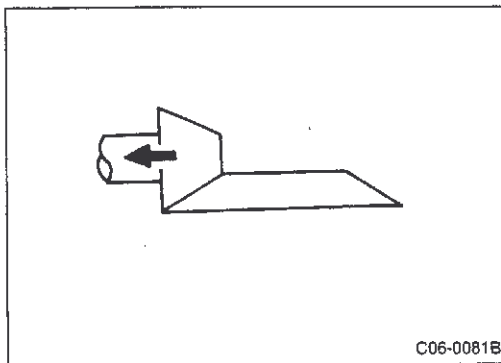

C06-0081B

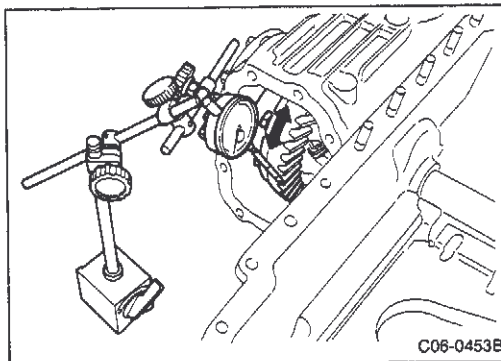

C06-0453B

- Place dial gauge on drive gear face and measure backlash.
Backlash standard value:
0.13 - 1.18 mm (0.0051 - 0.0465 in)
- If backlash is not within specification range, change thickness of carrier case side side bearing adjusting washer to adjust.

Excess backlash:	Use thicker washer.
Insufficient backlash:	Use thinner washer.

Side bearing adjusting washer (Carrier case side)

Thickness mm (in)	Part number	Thickness mm (in)	Part number	Thickness mm (in)	Part number
1.95 (0.0768)	38453 03V00	2.25 (0.0886)	38453 03V06	2.55 (0.1004)	38453 03V12
2.00 (0.0787)	38453 03V01	2.30 (0.0906)	38453 03V07	2.60 (0.1024)	38453 03V13
2.05 (0.0807)	38453 03V02	2.35 (0.0925)	38453 03V08	2.65 (0.1043)	38453 03V14
2.10 (0.0827)	38453 03V03	2.40 (0.0945)	38453 03V09		
2.15 (0.0846)	38453 03V04	2.45 (0.0965)	38453 03V10		
2.20 (0.0866)	38453 03V05	2.50 (0.0984)	38453 03V11		

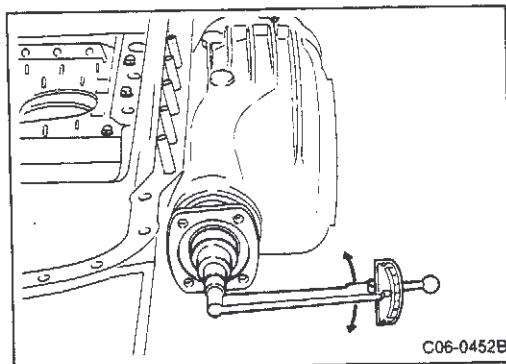

C06-0452B

① Total preload measurement

- Rotate companion flange more than 20 times. Use preload gauge to measure preload.
Total preload standard value (without oil seal):
1.5 - 2.1 N·m (0.15 - 0.21 kg·m, 1.1 - 1.5 ft·lb)
- If preload is not within specification range, adjust by selecting suitable adjusting shim thickness.

Excess preload:	Use thicker shim.
Insufficient preload:	Use thinner shim.

Side bearing adjusting washer (Carrier case side)

Thickness mm (in)	Part number	Thickness mm (in)	Part number	Thickness mm (in)	Part number
0.35 (0.0138)	38453 03V60	0.65 (0.0256)	38453 03V66	0.95 (0.0374)	38453 03V72
0.40 (0.0157)	38453 03V61	0.70 (0.0276)	38453 03V67	1.00 (0.0394)	38453 03V73
0.45 (0.0177)	38453 03V62	0.75 (0.0295)	38453 03V68	1.05 (0.0413)	38453 03V74
0.50 (0.0197)	38453 03V63	0.80 (0.0315)	38453 03V69	1.10 (0.0433)	38453 03V75
0.55 (0.0217)	38453 03V64	0.85 (0.0335)	38453 03V70	1.15 (0.0453)	38453 03V76
0.60 (0.0236)	38453 03V65	0.90 (0.0354)	38453 03V71		

C5 FINAL DRIVE

3. Final Drive Removal and Installation, Assembly and Disassembly (Cont'd)

[Point 9] Drive pinion and preload adjustment

a) Differential case assembly removal

- Insert screwdriver in side retainer notch and raise retainer.
- While pulling side retainer, tap gear lightly with plastic hammer and remove retainer.

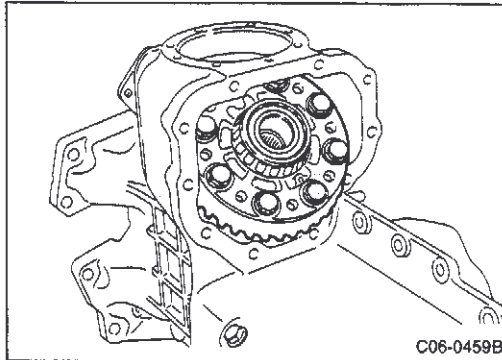
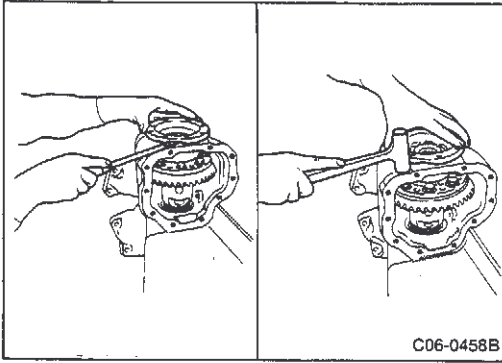

- Remove differential case assembly.

CAUTION:

Do not scratch carrier case surface.

b) Drive pinion assembly removal

- Use flange wrench and remove pinion lock nut.

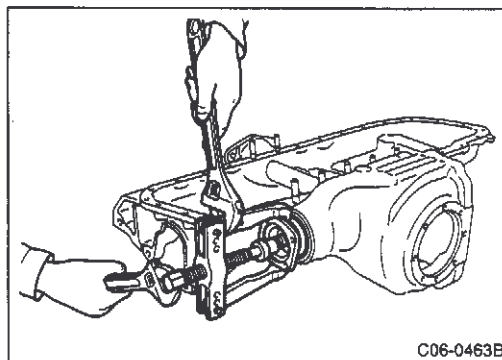
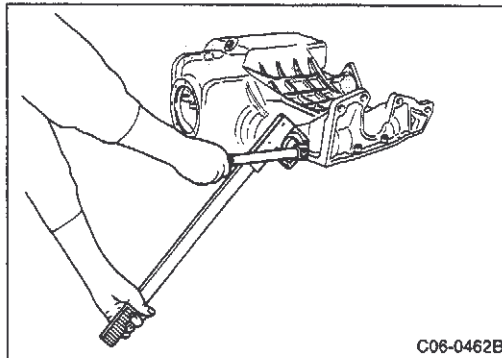

- Use puller (special service tool) and remove companion flange.

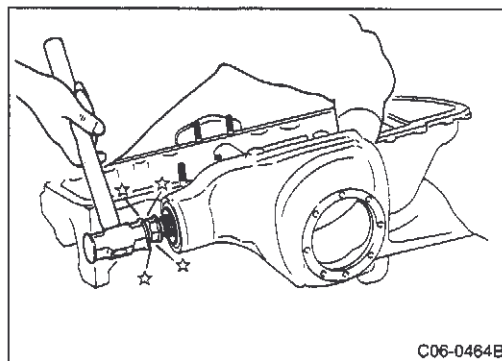

- Install pinion lock nut in drive pinion.

CAUTION:

Set drive pinion and pinion lock nut even to avoid damaging drive pinion threads.

- Use copper hammer and remove drive pinion from carrier case.

C5 FINAL DRIVE

3. Final Drive Removal and Installation, Assembly and Disassembly (Cont'd)

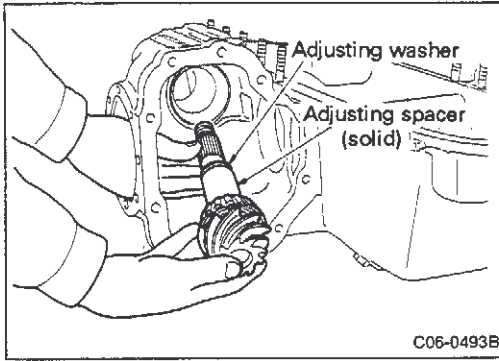

- Assemble adjusting spacer and washer on drive pinion and install in carrier case.

Note:

Spacer and washer must be same length and thickness as parts removed at disassembly.

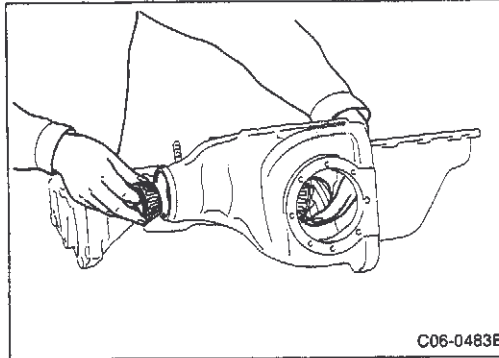

- Coat bearing with gear oil.
- Assemble drive pinion and bearing in carrier case.

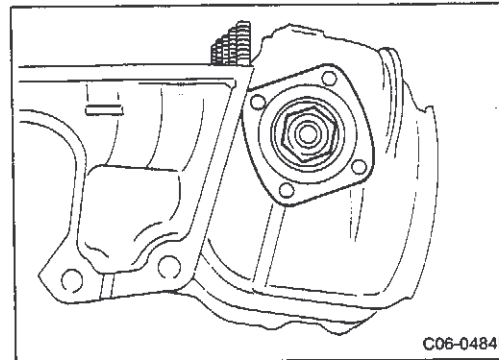

- Install companion flange without oil seal.
- Coat drive pinion threads and pinion nut seat with rust-preventative oil and tighten nut temporarily.

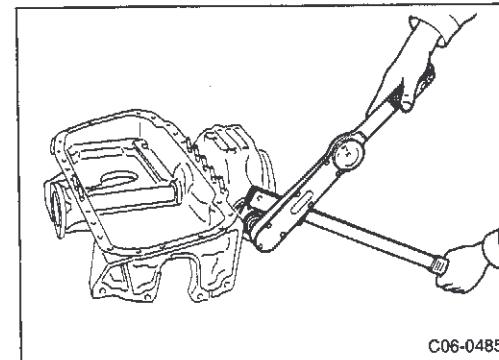

- Rotate companion flange and fit bearing.
- Use preload gauge, measure preload and tighten nut.
- When tightening to specified torque, select spacer and washer to set standard preload.

First use a long spacer and thick washer. Gradually, exchange for shorter spacer and thinner washer.

Drive pinion tightening torque:

167 - 196 N·m (17 - 20 kg-m, 123 - 145 ft-lb)

Pinion bearing preload standard value:

0.7 - 10.8 N·m (0.07 - 1.10 kg-m, 0.5 - 8.0 ft-lb)

If longer spacer and thicker washer are used:	the preload increases.
If shorter spacer and thinner washer are used:	the preload decreases.

CAUTION:

Do not increase preload excessively.

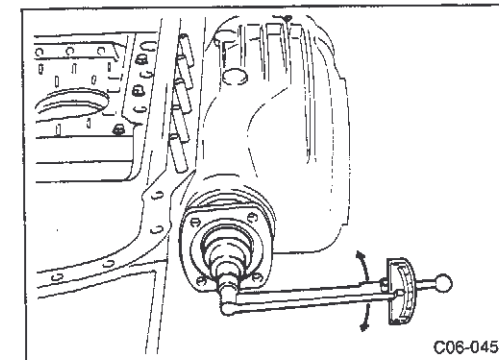

C5 FINAL DRIVE

3. Final Drive Removal and Installation, Assembly and Disassembly (Cont'd)

Pinion bearing adjusting spacer (solid)

Thickness mm (in)	Part number	Thickness mm (in)	Part number	Thickness mm (in)	Part number
56.2 (2.213)	38130 21000	56.6 (2.228)	38132 21000	57.0 (2.244)	38134 21000
56.4 (2.220)	38131 21000	56.8 (2.236)	38133 21000	57.2 (2.252)	38135 21000

Pinion bearing adjusting washer

Thickness mm (in)	Part number	Thickness mm (in)	Part number	Thickness mm (in)	Part number
2.59 (0.1020)	38127 09400	2.47 (0.0972)	38133 09400	2.35 (0.0925)	38139 09400
2.57 (0.1012)	38128 09400	2.45 (0.0965)	38134 09400	2.33 (0.0917)	38140 09400
2.55 (0.1004)	38129 09400	2.43 (0.0957)	38135 09400	2.31 (0.0909)	38141 09400
2.53 (0.0996)	38130 09400	2.41 (0.0949)	38136 09400		
2.51 (0.0988)	38131 09400	2.39 (0.0941)	38137 09400		
2.49 (0.0980)	38132 09400	2.37 (0.0933)	38138 09400		

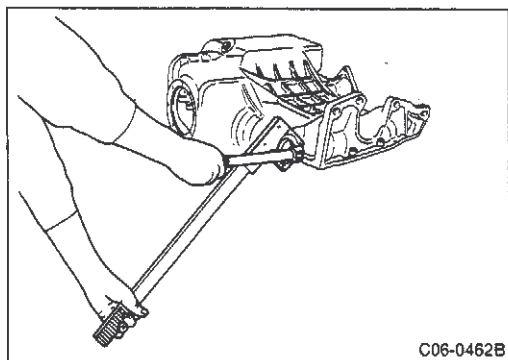

- If the specified preload (by adjusting spacer, adjusting washer selection) is set at specified torque, remove drive pinion one time.
- Use puller (special service tool) and remove companion flange.

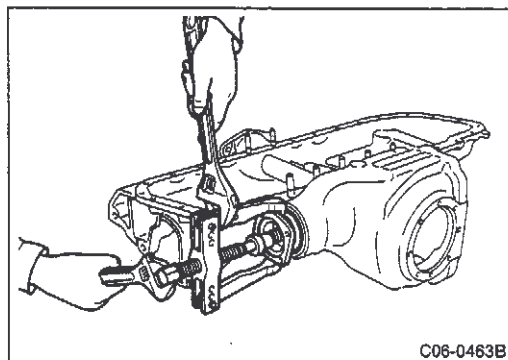

- Install pinion lock nut in drive pinion.

CAUTION:

Set drive pinion and pinion lock nut even to avoid damaging drive pinion threads.

- Use copper hammer and remove drive pinion from carrier case.

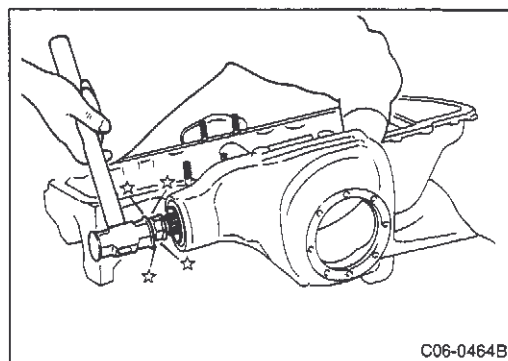

C5 FINAL DRIVE

3. Final Drive Removal and Installation, Assembly and Disassembly (Cont'd)

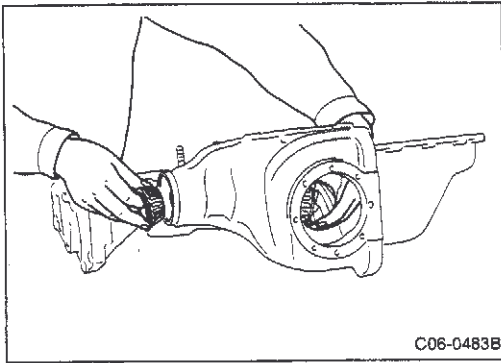

- Coat bearing with gear oil.
- Assemble drive pinion and selected adjusting spacer and washer in carrier case. Install bearing in case.

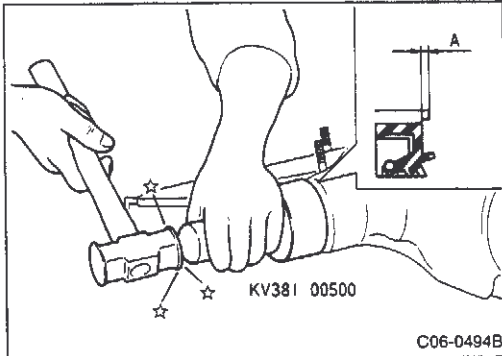

- Coat oil seal lip with Nissan MP special grease No. 2.
- Use drift (special service tool) and install oil seal to position of dimension A shown in figure on left.

Dimension A:

1.8 - 2.2 mm (0.071 - 0.087 in)

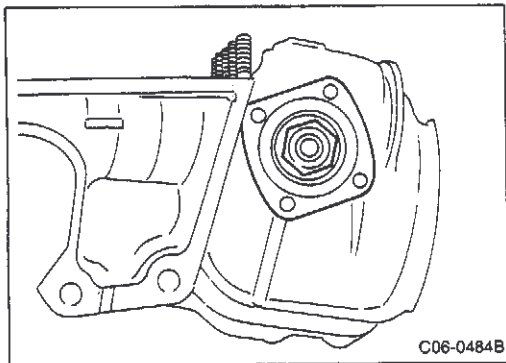

- Install companion flange.
- Coat drive pinion threads and pinion nut seat with rust-preventative oil and install new nut.

CAUTION:

Replace pinion nut with new part after every disassembly.

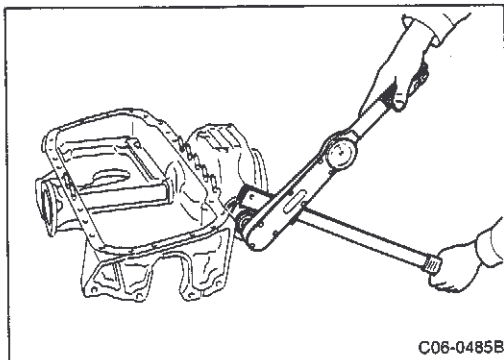

- Turn companion flange more than 20 times to fit bearing.
- Tighten drive pinion to specified torque.

Drive pinion tightening torque:

167 - 196 N·m (17 - 20 kg·m, 123 - 145 ft·lb)

CAUTION:

Do not over-tighten.

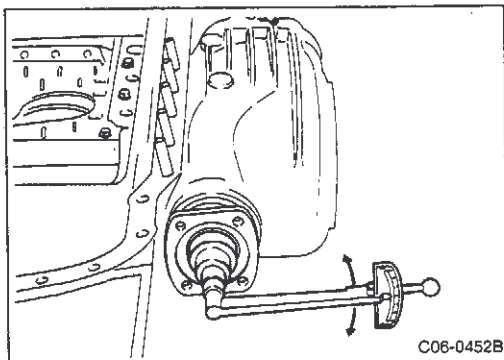

- Use preload gauge and measure preload.
Pinion bearing preload standard value (with oil seal installed):
0.8 - 1.1 N·m (0.08 - 0.11 kg·m, 0.6 - 0.8 ft·lb)

C5 FINAL DRIVE

3. Final Drive Removal and Installation, Assembly and Disassembly (Cont'd)

[Point 10] Differential case assembly installation

- Coat side bearing with gear oil. Install differential case assembly in carrier case.

CAUTION:

Do not scratch carrier case surface.

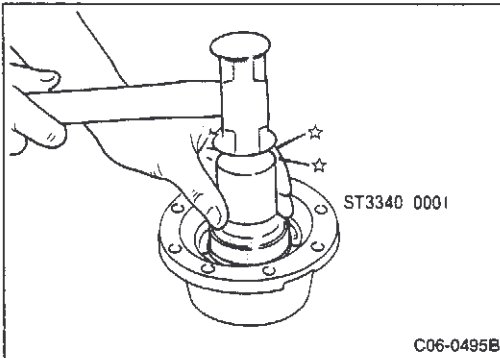
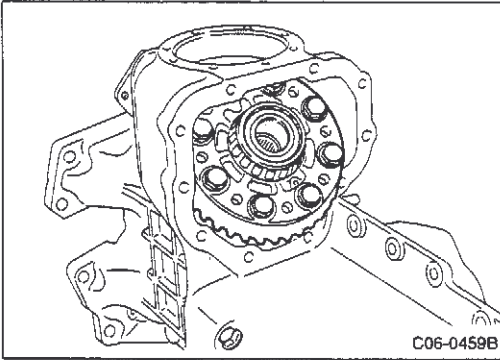

- Coat oil seal lip with Nissan MP special grease No. 2.
- Set drift (special service tool) in side retainer and install oil seal.

CAUTION:

After tightening bolt, wipe off extra liquid gasket inside case.

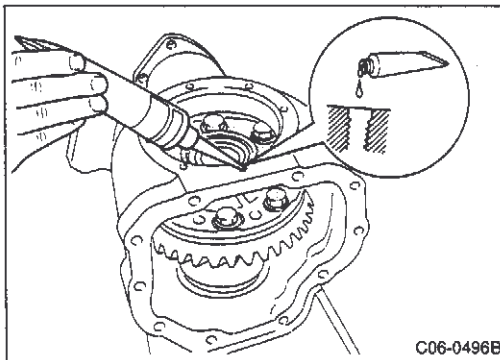

- Coat carrier case side retainer hole (through holes) with liquid gasket (silicon bond 1215 or equivalent).

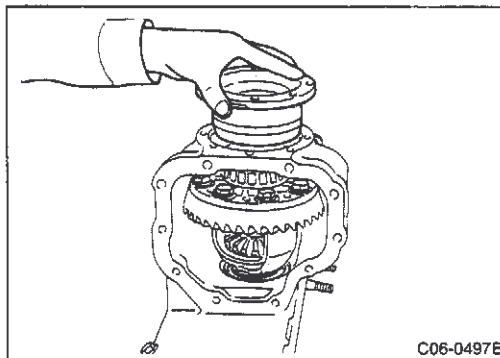

- Install selected side bearing adjusting shim and O-rings in side retainer. Assemble and install them in carrier case.

CAUTION:

Coat O-ring with gear oil and assemble after adjusting shim in carrier case side.

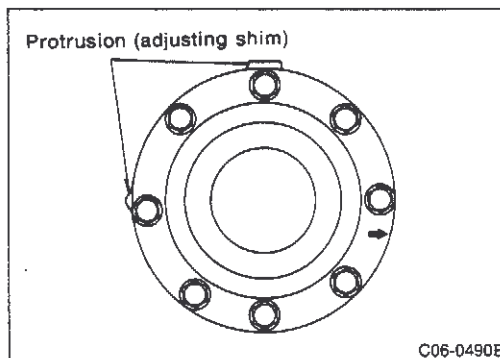

- Position adjusting shim so that the two protrusions face upper and rear side of carrier case and then install shim.
- Position side retainer facing front of carrier case (direction of arrow in figure) and install.

Tightening torque:

16 - 19 N·m (1.6 - 1.9 kg·m, 12 - 14 ft·lb)

C5 FINAL DRIVE

3. Final Drive Removal and Installation, Assembly and Disassembly (Cont'd)

[Point 11] Inspection after assembly

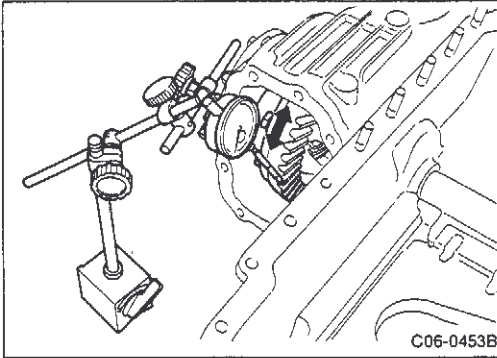

- Rotate drive pinion and drive gear a number of times. Set dial gauge on drive gear surface and measure backlash.
Backlash standard value:
0.13 - 0.18 mm (0.0051 - 0.0071 in)
- If backlash is not within specification range, select suitable side bearing washer thickness (carrier case side) to adjust.

Excessive backlash:	Use thinner side bearing carrier case side washer.
Insufficient backlash:	Use thicker side bearing carrier case side washer.

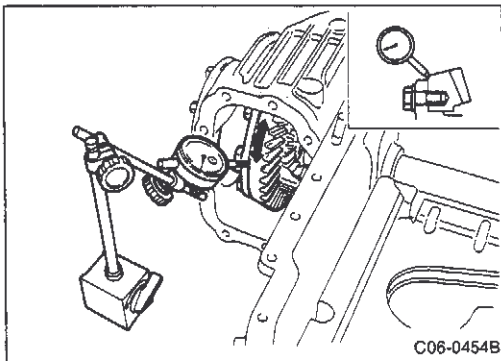

- Inspect drive gear runout.
Runout standard value:
0.05 mm (0.0020 in) max.
- Set dial gauge on drive gear rear surface. Rotate drive gear and measure runout.
- If runout is not within specification limit, inspect drive gear contact pattern (foreign matter between drive gear and differential case, deformation, etc.).
- If drive gear is deformed, replace hypoid assembly. If differential case is deformed, replace case.

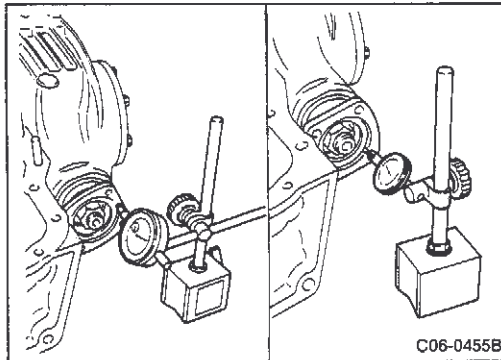

- Inspect companion flange runout.
Runout limit value:
0.05 mm (0.0020 in) max.
- Set dial gauge on companion flange surface (inside propeller shaft installation surface bolt hole) and measure runout.
- Set test indicator on inside of companion flange (inside lower surface) and measure runout.
- If runout exceeds specification limit, rotate relative positions of companion flange and drive pinion 90° and check if runout decreases.
- If runout still is not within specification range even if the relative position is changed, replace companion flange.
- If companion flange is replaced and runout is still not within specification range, the problem may be due to poor contact between pinion bearing and drive pinion or faulty pinion bearing.

C5 FINAL DRIVE

3. Final Drive Removal and Installation, Assembly and Disassembly (Cont'd)

- Rotate companion flange more than 20 times. Use preload gauge to measure total preload.

**Total preload standard value
(with oil seal installed):**

1.6 - 2.2 N·m (0.16 - 0.22 kg-m, 1.2 - 1.6 ft-lb)

- If the preload is not within specification range, adjust pinion bearing preload and side bearing preload.

Excessive preload:	<ul style="list-style-type: none"> ● Use shorter drive pinion spacer and thinner washer. ● Use thicker side bearing retainer shim.
Insufficient preload:	<ul style="list-style-type: none"> ● Use longer drive pinion spacer and thicker washer. ● Use thinner side bearing retainer shim.

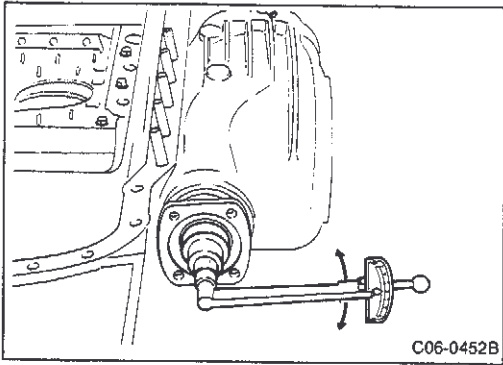

[Point 12] Side shaft assembly installation

- Use drift (special service tool) to install bearing in retainer.

CAUTION:

Do not install bearing on inclined angle.

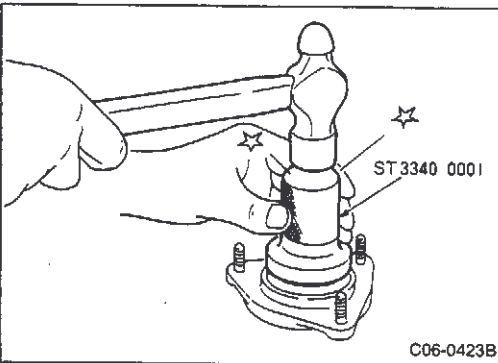

- Coat oil seal lip with Nissan MP special grease No. 2.
- Use drift (special service tool) and install oil seal in retainer.

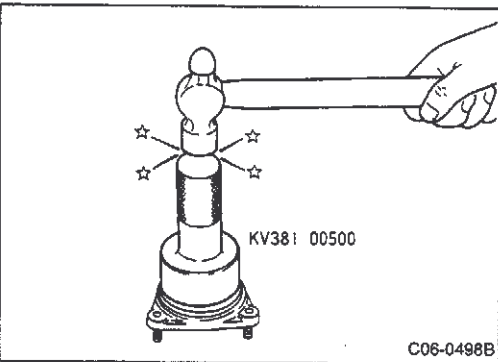

- Use drift (special service tool) and install side shaft in retainer.

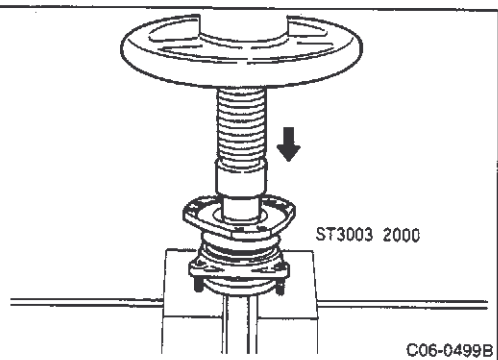

C5 FINAL DRIVE

3. Final Drive Removal and Installation, Assembly and Disassembly (Cont'd)

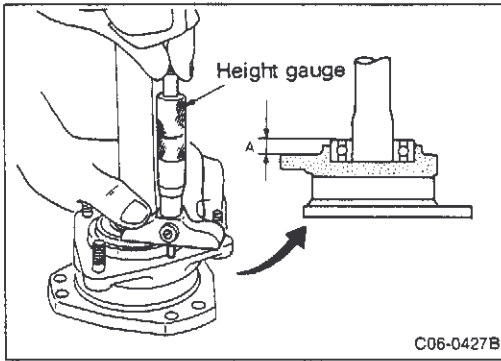

- Measure dimension A in side shaft to calculate side shaft end play.

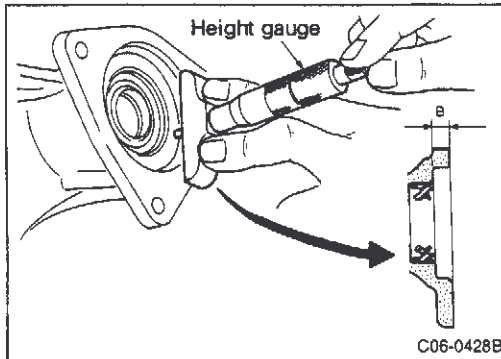

- Measure dimension B in carrier case.

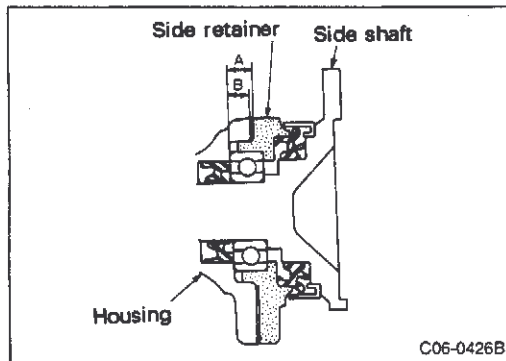

- Select adjusting shim so axial end play is within specification range indicated below.

Axial end play standard value (A - B):
0 - 0.1 mm (0 - 0.004 in)

Side retainer adjusting shim

Thickness mm (in)	Part number	Thickness mm (in)	Part number
0.1 (0.004)	38233 03V01	0.4 (0.016)	38233 03V04
0.2 (0.008)	38233 03V02	0.5 (0.020)	38233 03V05
0.3 (0.012)	38233 03V03		

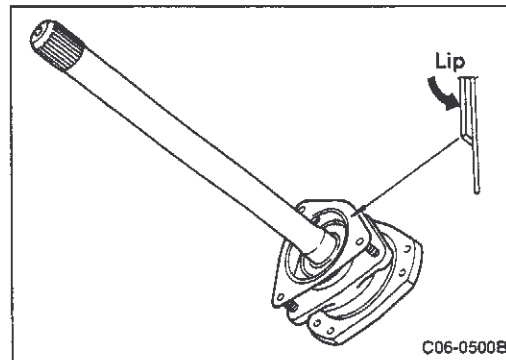

- Assemble selected adjusting shim and spacer in side shaft.
- CAUTION:**
Assemble adjusting shim in retainer and spacer in carrier case with lip (projection) facing carrier case side before installation.

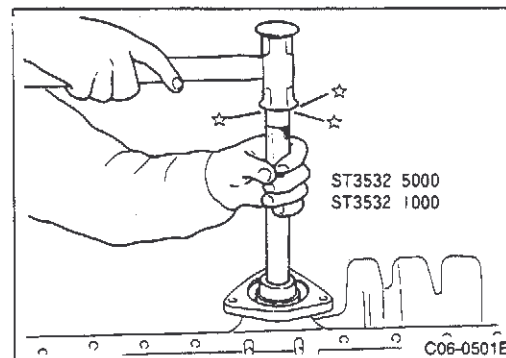

- Coat oil seal lip with Nissan MP special grease No. 2.
- Use drift (special service tool) and install oil seal in carrier case.

C5 FINAL DRIVE

3. Final Drive Removal and Installation, Assembly and Disassembly (Cont'd)

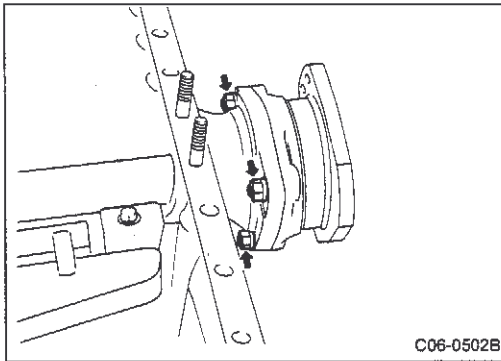

- Install side shaft assembly in carrier case.
Tightening torque:
16 - 21 N·m (1.6 - 2.1 kg-m, 12 - 15 ft-lb)

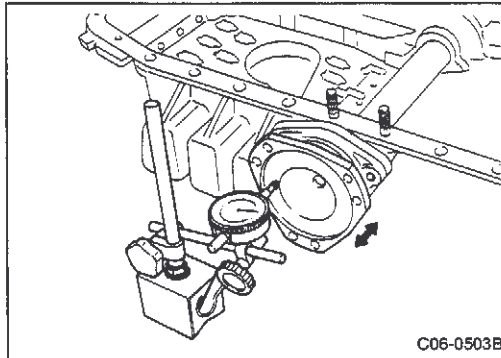

- Measure axial end play.
Axial end play standard value:
0 - 0.1 mm (0 - 0.004 in)

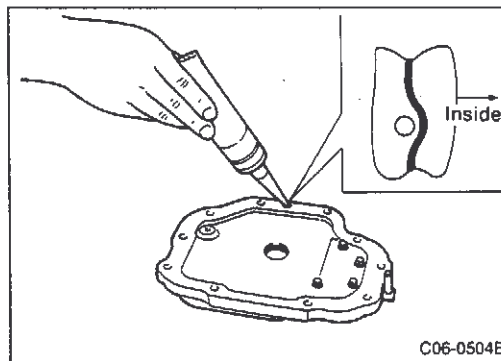

[Point 13] Carrier cover installation

- Apply a thin coat of liquid gasket (silicone bond 1215 or equivalent) to installation surface bolt holes of carrier cover and carrier case.

CAUTION:

Remove all traces of old liquid gasket from mating surfaces with a scraper. Wipe off any other oil, dust or foreign matter from mating surfaces.

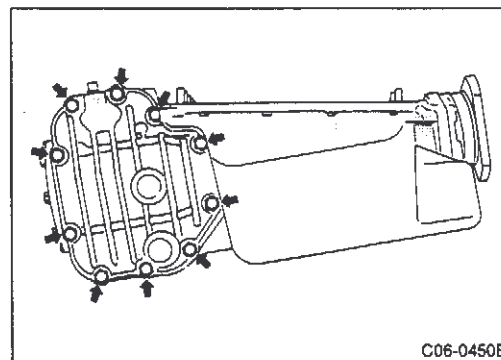

- Install carrier cover in carrier case.
Tightening torque:
29 - 37 N·m (3.0 - 3.8 kg-m, 22 - 27 ft-lb)
- Apply a thin coat of liquid gasket (silicon bond 1215 or equivalent) to drain plug and filler plug and install in carrier case cover.

Drain plug tightening torque	25 - 34 N·m (2.5 - 3.5 kg-m, 18 - 25 ft-lb)
Filler plug tightening torque	

Note:

Final drive must be filled with gear oil after installation in vehicle. Refer to the 1-1. SPECIFICATION for the oil volume.

C5 FINAL DRIVE

3. Final Drive Removal and Installation, Assembly and Disassembly (Cont'd)

(2) Rear final drive [R200 (mechanical LSD)]

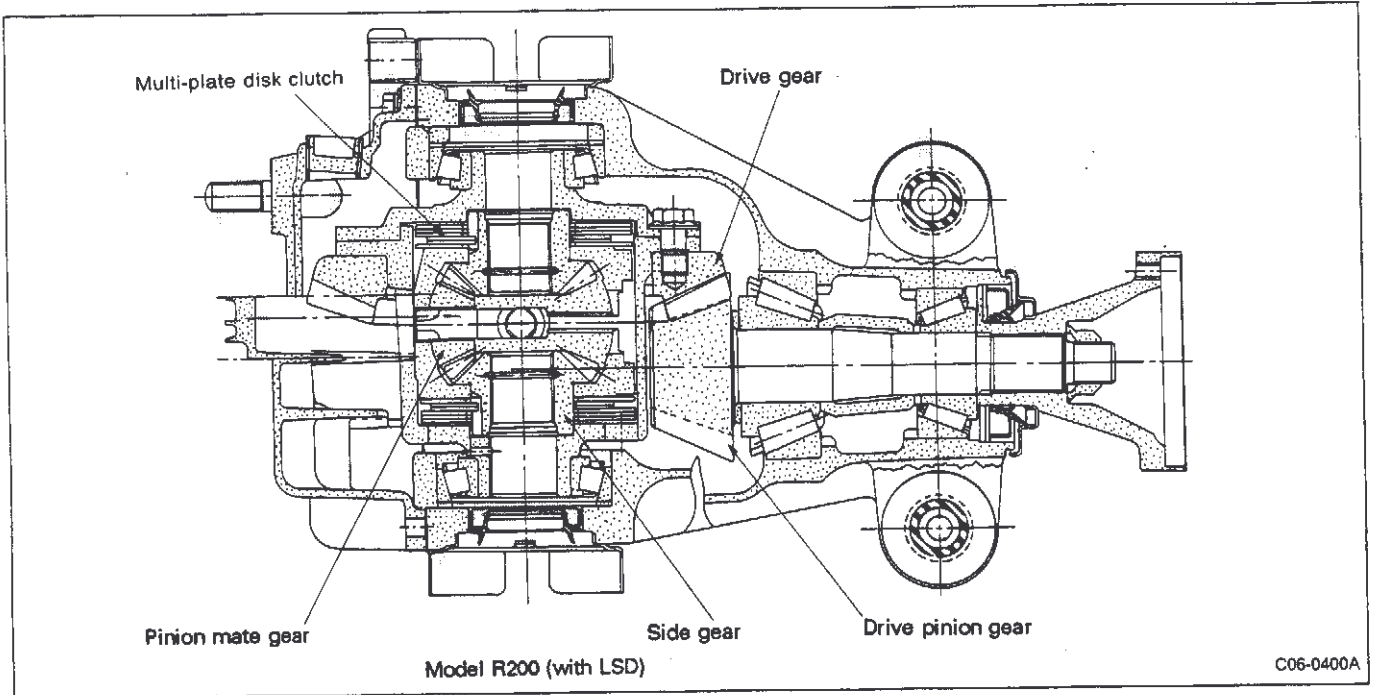

C5 FINAL DRIVE

3. Final Drive Removal and Installation, Assembly and Disassembly (Cont'd)

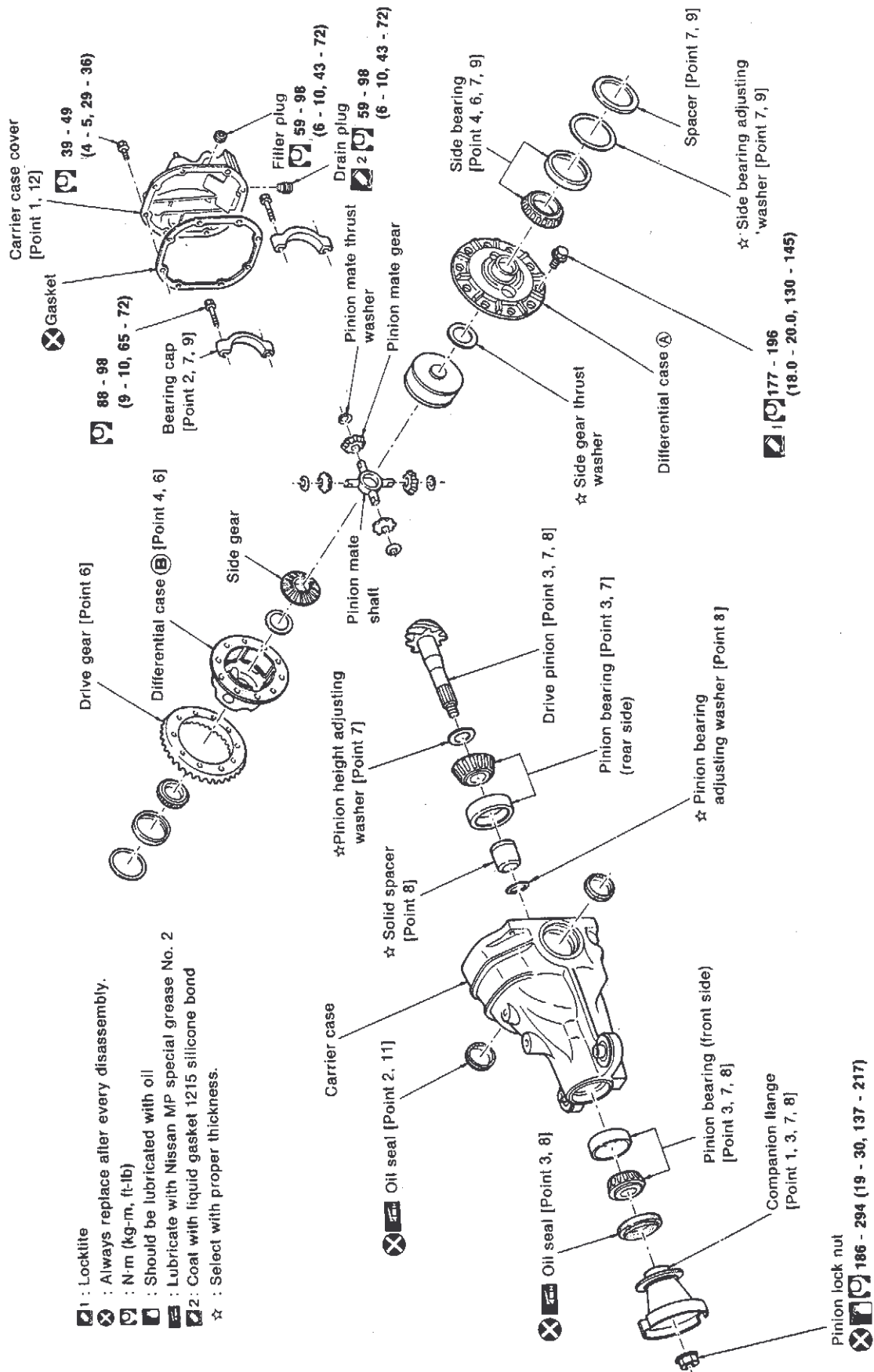

- ① : Locktite
- ⊗ : Always replace after every disassembly.
- Ⓜ : N·m (kg-m, ft-lb)
- ④ : Should be lubricated with oil
- ⑤ : Lubricate with Nissan MP special grease No. 2
- ② : Coat with liquid gasket 1215 silicone bond
- ☆ : Select with proper thickness.

C5 FINAL DRIVE

3. Final Drive Removal and Installation, Assembly and Disassembly (Cont'd)

[Point 1] Inspection before disassembly

- Secure attachment on unit assembly.
- Drain oil from gears.
- Remove gear case cover.

CAUTION:

If carrier case is faulty, replace unit assembly.

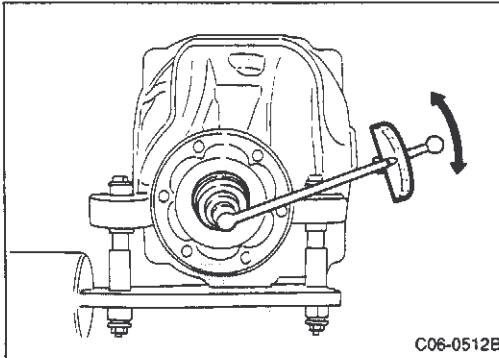
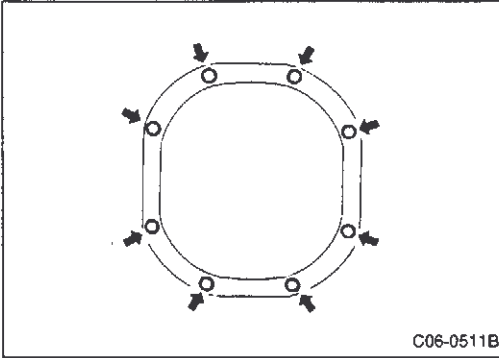

a) Total preload inspection

- Rotate companion flange more than 20 times. Measure total preload with preload gauge.
 - Total preload standard value: (With oil seal)**
1.4 - 3.1 N·m (0.14 - 0.32 kg-m, 1.0 - 2.3 ft-lb)
- If preload is not within specification range, adjust pinion bearing preload and side bearing preload.

Collapsible spacer

Excessive preload:	<ul style="list-style-type: none"> ● Use longer drive pinion spacer and thicker washer. ● Use thinner side bearing washer.
Insufficient preload:	<ul style="list-style-type: none"> ● Use shorter drive pinion spacer and thinner washer. ● Use thicker side bearing washer.

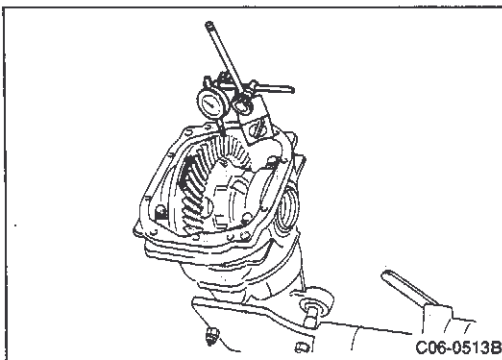

b) Hypoid gear and backlash inspection

- Set dial gauge on drive gear face and measure backlash.
 - Backlash standard value:**
0.13 - 0.18 mm (0.0051 - 0.0071 in)
- If the backlash is not within specification range, adjust side washer thickness by moving equally in both directions.

Excessive backlash:	<ul style="list-style-type: none"> Use thicker drive gear rear washer. Use thinner drive gear tooth surface side washer.
Insufficient backlash:	<ul style="list-style-type: none"> Use thinner thickness drive gear rear side washer. Use thicker drive gear tooth surface side washer.

C5 FINAL DRIVE

3. Final Drive Removal and Installation, Assembly and Disassembly (Cont'd)

Ⓒ Drive gear rear surface runout inspection

- Place dial gauge on rear surface of drive gear. Turn drive gear and measure runout.

Runout limit:

0.05 mm (0.0020 in) max.

- If runout exceeds limit, check drive gear assembly condition (foreign matter jammed between drive gear and differential case, deformation of differential case or drive gear, etc.).
- If drive gear is faulty, replace hypoid gear assembly. If differential case is faulty, replace case.

Ⓓ Companion flange runout inspection

- Place dial gauge on companion flange (propeller shaft installation surface) and measure runout.

Runout limit:

0.05 mm (0.0020 in) max.

- Set test indicator inside companion flange (inner lower surface) and measure runout.

Runout limit:

0.05 mm (0.0020 in) max.

CAUTION:

If measurement surface is rusted, remove rust before measurement.

- If runout exceeds specification limit, rotate relative positions of companion flange and drive pinion 90° and find minimum value.
- If runout still is not within specification range even if the relative position is changed, replace companion flange.
- If companion flange is replaced and runout is still not within specification range, the problem may be due to poor contact between pinion bearing and drive pinion or faulty pinion bearing.

Ⓔ Hypoid gear tooth contact inspection

- Clean drive gear and hypoid gear teeth. Apply a light mixture of powdered titanium oxide and oil (or equivalent compound) to 4 locations on drive gear. Rotate hypoid gear and check gear tooth contact pattern.
- Check gear tooth contact pattern on drive side (acceleration) and back side (deceleration) of gears.

CAUTION:

Refer to Ⓖ Hypoid drive gear tooth contact pattern for details on using powdered titanium mixture.

- If gear tooth contact pattern is incorrect, select suitable washer to adjust gear height.

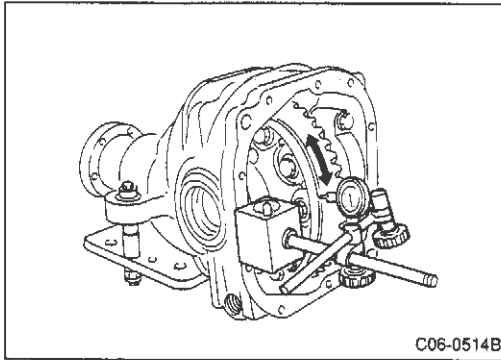

C06-0514B

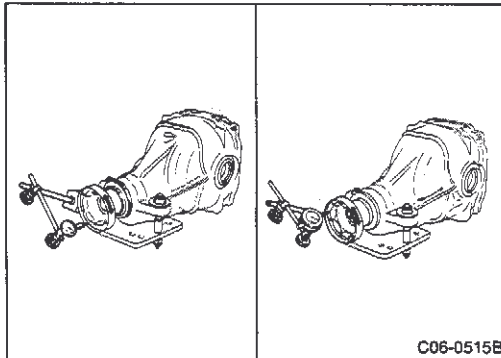

C06-0515B

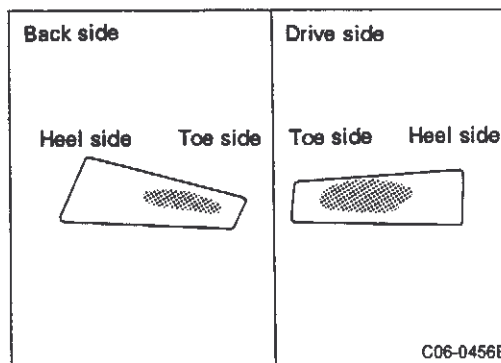

C06-0456B

C5 FINAL DRIVE

3. Final Drive Removal and Installation, Assembly and Disassembly (Cont'd)

[Point 2] Drive gear and differential case assembly removal

- Check for painted mark used to align side bearing cap and carrier case. If there is no mark, paint mark in correct location.

CAUTION:

The bearing cap and carrier case are assembled as a single unit. Be especially careful not to assemble incorrectly. Paint mating marks and do not scratch surfaces.

- Remove bearing cap bolts. Tap bearing caps lightly with plastic hammer and remove.
- Using slide hammer (commercial service tool) separate differential case assembly and carrier case.

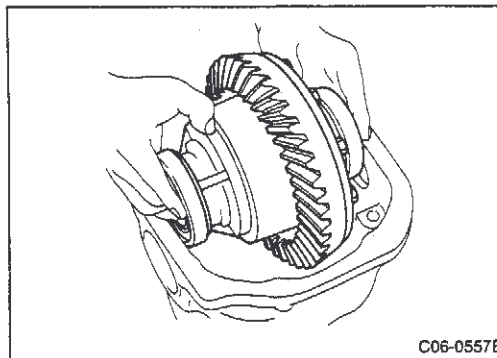
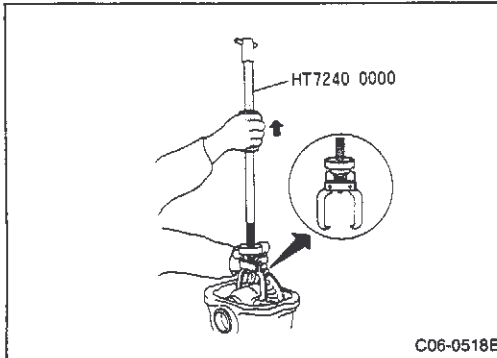
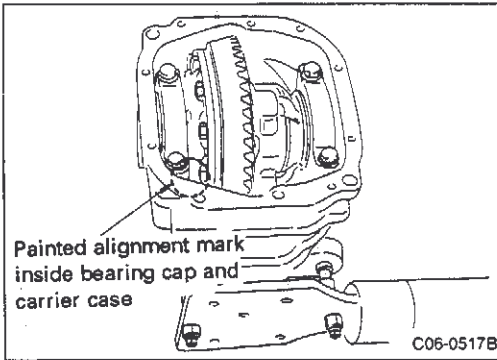

- Remove differential case assembly together with side bearing outer race.

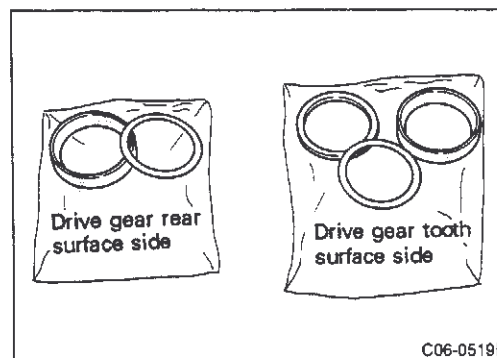

- Separate side bearing outer race, adjusting washers and bearing spacers by front surface and gear tooth surface when they are stored.
- The bearing spacer installation position varies by hypoid gear and gear ratio.

Gear ratio	Installation position
3.916 min.	Drive gear rear side

- Use brass shaft to remove oil seal from carrier case.

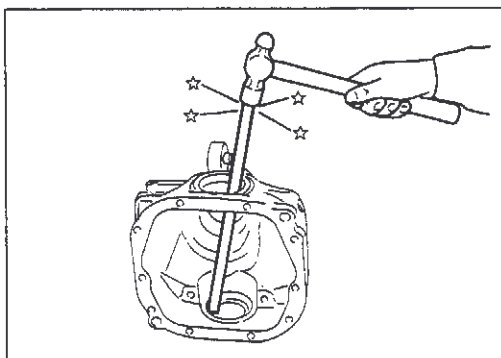

C5 FINAL DRIVE

3. Final Drive Removal and Installation, Assembly and Disassembly (Cont'd)

[Point 3] Drive pinion assembly removal

- Using cam sprocket wrench (special service tool), remove pinion lock nut.

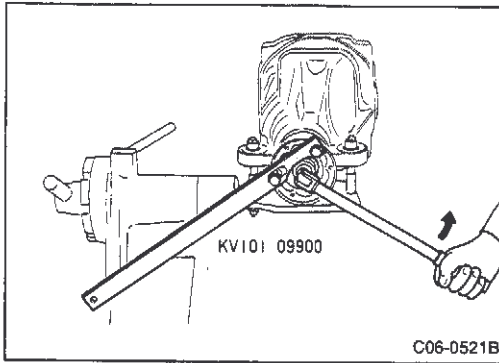

- Use drift (special service tool) to remove drive pinion assembly.

CAUTION:

Do not allow drive pinion to fall.

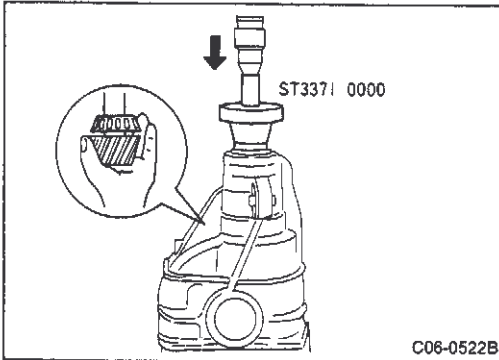

- Use brass shaft and tap evenly to remove outer bearing race.
- Remove bearing and oil seal together from front side.

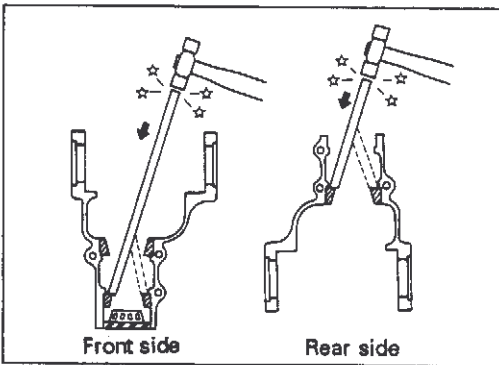

- Using bearing replacer (special service tool), remove rear pinion bearing from drive pinion.

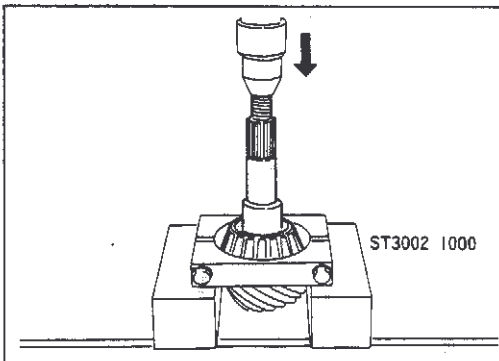

C5 FINAL DRIVE

3. Final Drive Removal and Installation, Assembly and Disassembly (Cont'd)

[Point 4] Differential case disassembly

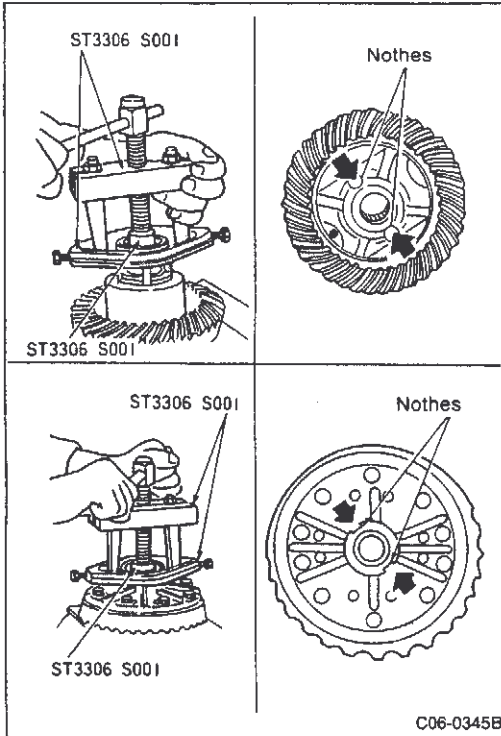

(a) Side bearing removal

- Secure differential case assembly in vice. Using side puller set (special service tool), remove side bearing from differential case.

CAUTION:

- Place copper plates on sides of bearing and drive to prevent scratches when securing case assembly in vise.
- Do not remove any other parts except when replacing side bearings.

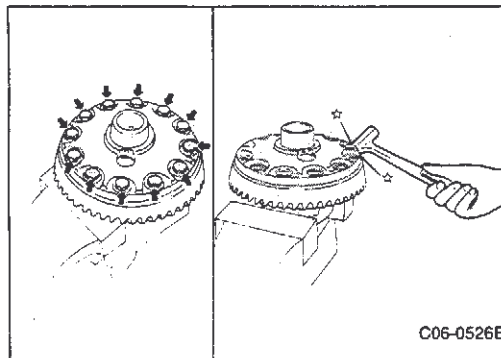

(b) Drive gear removal

- Remove bolts from drive gear.
- Tap side of drive gear with plastic hammer to remove drive gear.

(c) Part inspection

- Clean disassembled parts thoroughly and inspect for wear, damage and other abnormalities. Perform the following operations for non-standard conditions.

Item	Operation
Hypoid gear	<ul style="list-style-type: none"> If gear tooth contact is incorrect, determine cause and adjust so contact is correct. If gear tooth surface is worn, cracked or seized, replace gear set.
Bearing	<ul style="list-style-type: none"> Rotate by hand to check for seizing, separation, wear and rust. Replace bearings as a matched set of inner or outer races if there is abnormal noise or other damage.
Oil seal	<ul style="list-style-type: none"> Always replace after every disassembly. Replace if lip is worn, sealing power is reduced or there is other damage.
Companion flange	<ul style="list-style-type: none"> Replace if oil seal lip contact surface is worn [approx. 0.1 mm (0.004 in)] or damaged.

C5 FINAL DRIVE

3. Final Drive Removal and Installation, Assembly and Disassembly (Cont'd)

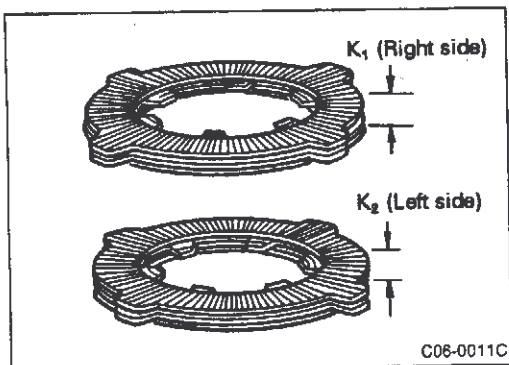
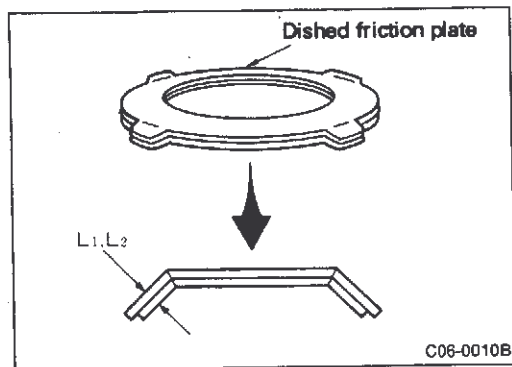
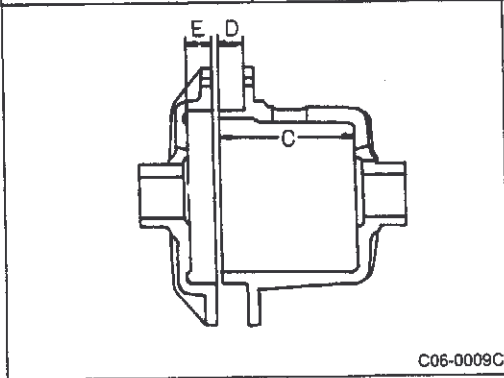
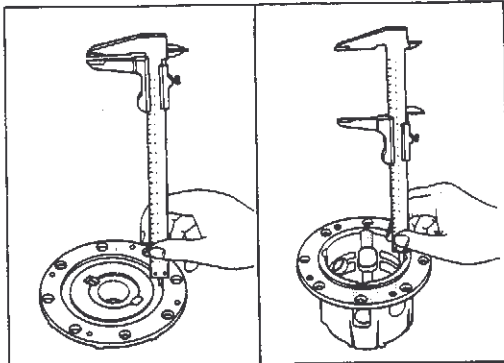

Ⓒ Friction disk selection

- Before assembling differential case, select friction disk to adjust axial direction clearance of mechanical parts in case.
- Use the following method to select parts.
- Measure differential case depth as shown in figure. Use the following equation to calculate dimension "A".

$$A = C + E - D$$
 A: Differential case depth

- Measure the total layered thickness of the two dished friction plates as shown in figure on left.
 Right side: L_1
 Left side: L_2

- Measure the total layered thickness of the two friction plates and one spacer as shown in figure on left.
 Right side: K_1
 Left side: K_2

- Compare the left and right total thickness of the dished friction plates, friction plate, friction disk and spacer. Change assembly alignment if difference of left and right thicknesses is not within specification.
 Difference of left and right: $B = (L_1 + K_1) - (L_2 + K_2)$
Left-right difference limit:
 0.05 mm (0.0020 in)

C5 FINAL DRIVE

3. Final Drive Removal and Installation, Assembly and Disassembly (Cont'd)

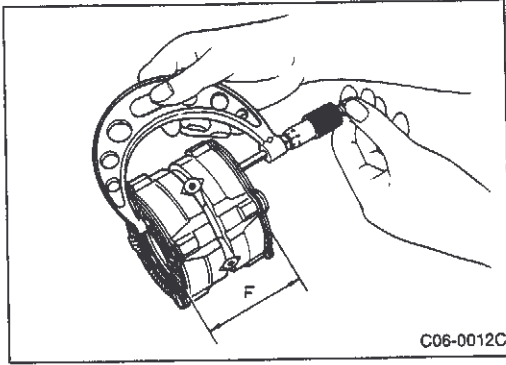

- Assemble pinion mate shaft, pressure ring, friction disk, friction plate and spacer. Measure total width of assembled parts.

Assembly dimension: F

CAUTION:

Do not include the thickness of dished friction plates in these measurements.

- Use the following equation to determine axial clearance from the dimension of differential case depth and friction plate assembly.

$$\text{Axial clearance: } S = A - (F + L_1 + L_2)$$

Axial clearance specification:

0.05 - 0.20 mm (0.0020 - 0.0079 in)

- Select suitable friction disk to adjust axial clearance within specification.

Friction plate types

Thickness mm (in)	Part number
1.75 (0.0689)	38432 N9000
1.85 (0.0728)	38432 N9001

- Check the left-right difference of the friction plate types. Change the assembly alignment if the difference of left and right thicknesses is not within specification.

CAUTION:

Be careful not to mix the left and right sides of the friction plates after selection.

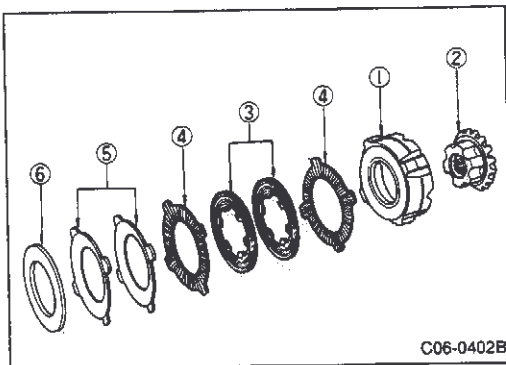

④ Plate assembly

- Be careful not to mistake the assembly direction and sequence of any plate.

- ① Pressure ring
- ② Side gear
- ③ Friction disk
- ④ Friction plate
- ⑤ Dish friction plate
- ⑥ Spacer

CAUTION:

Coat each part with recommended Nissan gear oil hypoid GL-5 80W-90LS.

C5 FINAL DRIVE

3. Final Drive Removal and Installation, Assembly and Disassembly (Cont'd)

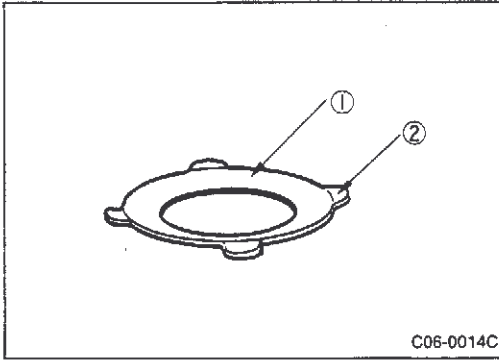

⑥ Part inspection

- Clean disassembled parts with proper solvent, dry with compressed air and check as follows.

Dished friction plate

- Make sure there is no seizing or discoloration on friction surface (left figure ①). Replace if necessary because damage may cause abnormal lock performance.
- Make sure there are no bumps or damage on outer protrusion (left figure ②). Correct with oil stone or replace if necessary.
- Check friction distance with micrometer. Replace plate if wear exceeds limit.

Friction distance = outer protrusion ② thickness – outer friction surface ① thickness

CAUTION:

Measure at four opposite angles.

Wear limit:

0.1 mm (0.004 in)

CAUTION:

The inside section of friction sliding surface does not wear abnormally due to strong contact force applied to spring force of the dished friction plate.

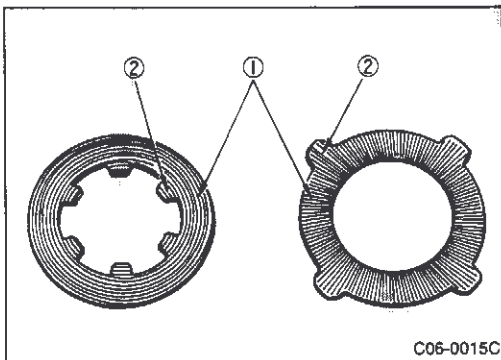

Friction plate and friction disk

- Check for seizing or discoloration on friction surface (left figure ①) and replace if necessary.
- Make sure there are no bumps or damage on outer protrusion (left figure ②). Correct with oil stone or replace if necessary.
- Check friction distance with micrometer. Replace plate if wear exceeds limit.

Inspection items are the same as for dished friction plate.

Wear limit:

0.1 mm (0.004 in)

- Use dial gauge and check for distortion.

Distortion limit:

Total runout 0.08 mm (0.0031 in)

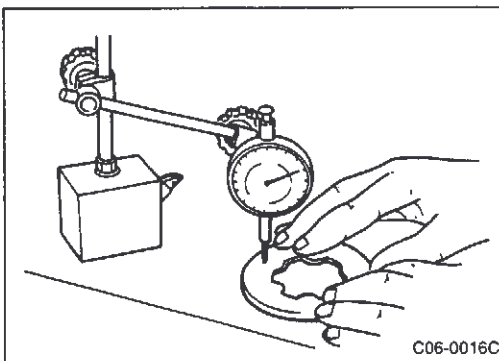

C5 FINAL DRIVE

3. Final Drive Removal and Installation, Assembly and Disassembly (Cont'd)

Pressure ring

- Check the contact surface of the friction disk (left figure ①) for dents, damage, or heat discoloration color. Replace if heat discoloration is evident. Use an oil stone to correct small dents or damage. Replace if correction is not possible.

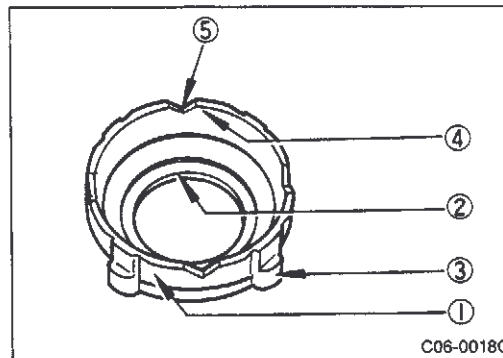
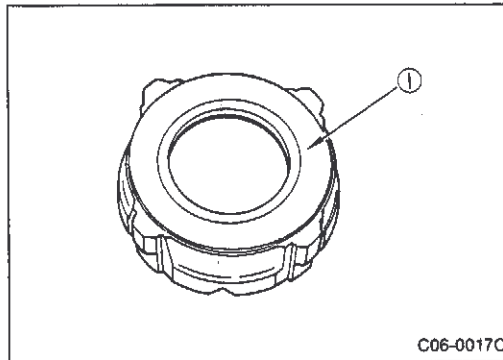

- Check for wear or damage to contact sliding part of the mechanism (described below).

- ① Differential case connection part
- ② Side gear contact part
- ③ Outer protrusion
- ④ Pinion mate gear contact part
- ⑤ V-shaped groove

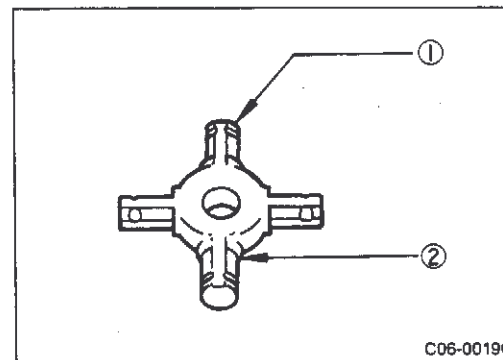

Pinion mate shaft

- Check cams (left figure ①) for wear or damage. Check shaft (left figure ②) for abnormal wear or heat discoloration and replace if necessary.

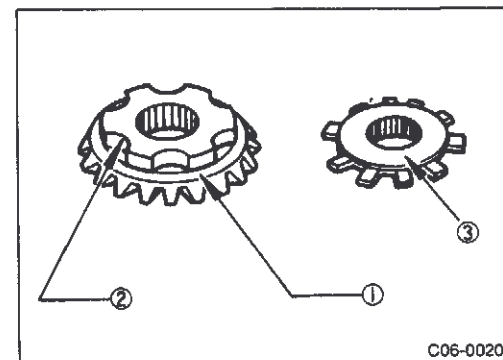

Side gear and pinion mate gear

- Inspect following parts and correct light damage with oil stone. Replace if there is abnormal wear or heat discoloration.
- ① Pressure ring sliding contact surface (left figure ①) for abnormal wear or heat discoloration.
- ② Groove part (left figure ②) for damage or abnormal wear.
- ③ Rear side (left figure ③) for abnormal wear.

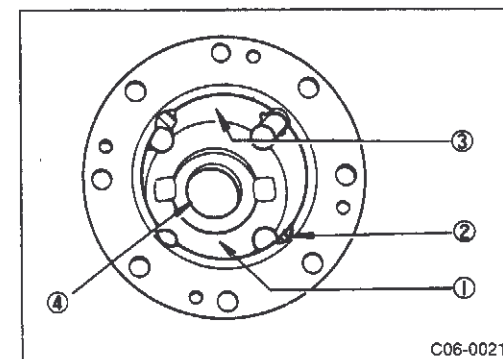

Differential case

- Inspect parts described below for damage, abnormal wear and heat discoloration. Replace as necessary.
- ① Spacer contact surface (left figure ①) for abnormal wear or heat discoloration.
- ② Groove part (left figure ②) for damage or abnormal wear.
- ③ Pressure ring contact surface (left figure ③) for damage, abnormal wear or heat discoloration.

C5 FINAL DRIVE

3. Final Drive Removal and Installation, Assembly and Disassembly (Cont'd)

Spacer

- Check pressure ring and differential case contact surfaces for damage, heat discoloration or abnormal wear.

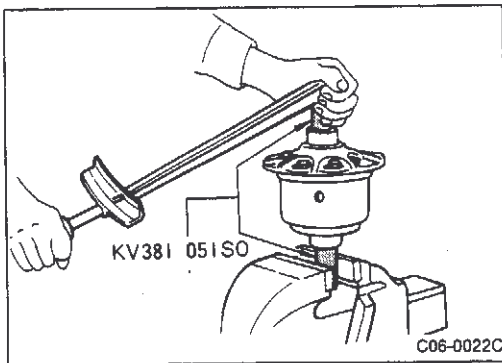

① LSD assembly inspection

- After LSD assembly is assembled, check rotary motion torque and make sure transmitted torque is correct.
- Using dummy rear acceleration shaft (special service tool) and measure rotational torque with torque wrench.

Rotational torque standard value:

25 - 34 N·m (2.5 - 3.5 kg-m, 18 - 25 ft-lb)

Note:

After measurement rotation is smooth, lubricate each sliding part with recommended Nissan gear oil hypoid GL-5 80W-90LS to ensure proper smoothness. Measure rotational torque again at initial rotation after lubrication.

- If rotational torque is not within specification range, inspect friction plate and friction disk and assemble again.

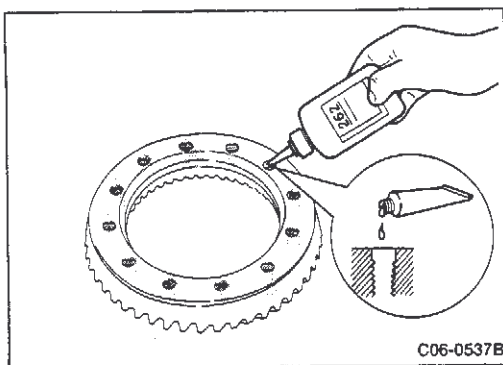

[Point 6] Differential case assembly

- Apply 1 - 2 drops of Loctite to drive gear threads.

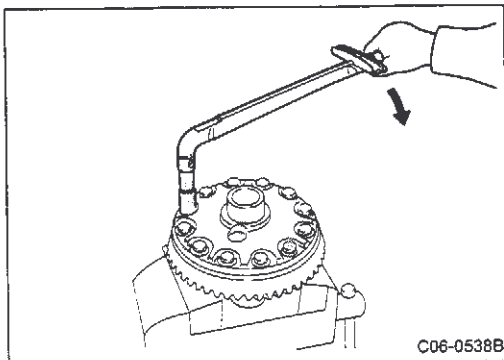

- Assemble drive gear and differential case.
- Coat gear oil to bolt seat and tighten bolts in criss-cross sequence.

Tightening torque:

177 - 196 N·m (18.0 - 20.0 kg-m, 130 - 145 ft-lb)

C5 FINAL DRIVE

3. Final Drive Removal and Installation, Assembly and Disassembly (Cont'd)

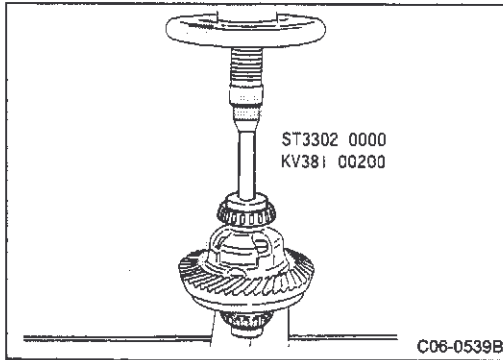

- Use drift (special service tool) and press-fit side bearing in differential case.

CAUTION:

Tap bearing lightly with hammer to start press-fit operation. Make sure bearing is perpendicular to differential case and press-fit bearing.

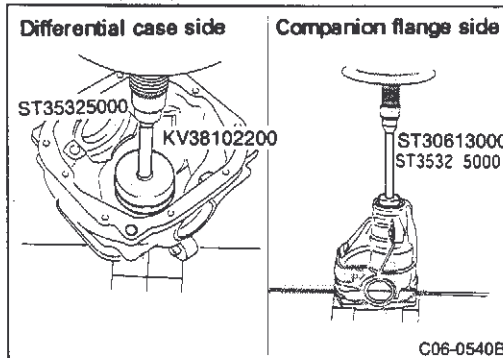

[Point 7] Hypoid gear tooth contact inspection and backlash inspection

(a) Pinion bearing outer race installation

- Using drift (special service tool), install pinion bearing outer race in carrier case.

CAUTION:

Tap outer race lightly with hammer to start press-fit operation. Making sure outer race is perpendicular to carrier case and press-fit bearing.

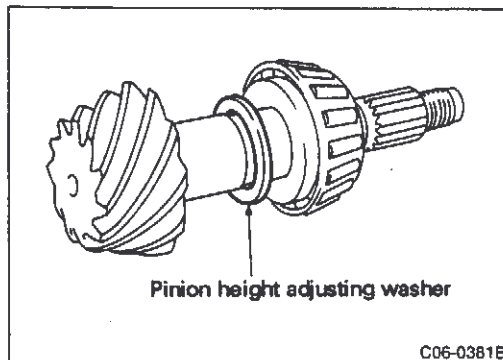

(b) Pinion height adjusting washer installation (temporary assembly)

- Assemble height washer in drive pinion.

CAUTION:

Assemble height washer that was removed. When using new part, make sure it is the same thickness as when it was disassembled.

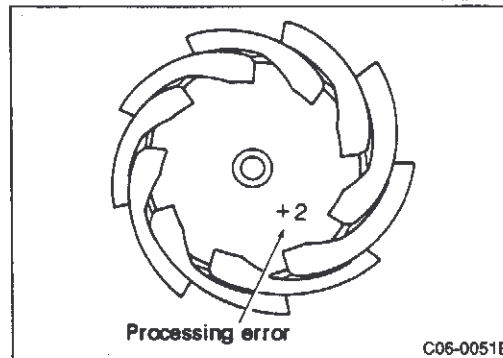

(c) Gear set replacement washer selection

- When hypoid gear set is replaced, perform processing error correction using measurement of old and new drive pinions and select suitable washer.
- Processing error correction

$$T = T_0 + (t_1 - t_2)$$

T = Washer thickness that must be assembled

T₀ = Thickness of removed washer

t₁: Head number of old drive pinion

t₂: Head number of new drive pinion

[The processing error is indicated in units of 100 × 1/100 mm.]

[The processing error is indicated in units of 100 × 1/100 mm.]

Calculation example:

If: T₀ = 3.21, t₁ = +2 and t₂ = -1

$$T = 3.21 + [(2 \times 0.01) - (-1 \times 0.01)] = 3.24 \text{ mm}$$

- Assemble temporary adjusting washer (3.24 mm) in drive pinion.

Thickness mm (in)	Part number	Thickness mm (in)	Part number
3.09 (0.1217)	38154 P6017	3.39 (0.1335)	38154 P6027
3.12 (0.1228)	38154 P6018	3.42 (0.1346)	38154 P6028
3.15 (0.1240)	38154 P6019	3.45 (0.1358)	38154 P6029
3.18 (0.1252)	38154 P6020	3.48 (0.1370)	38154 P6030
3.21 (0.1264)	38154 P6021	3.51 (0.1382)	38154 P6031
3.24 (0.1276)	38154 P6022	3.54 (0.1394)	38154 P6032
3.27 (0.1287)	38154 P6023	3.57 (0.1406)	38154 P6033
3.30 (0.1299)	38154 P6024	3.60 (0.1417)	38154 P6034
3.33 (0.1311)	38154 P6025	3.63 (0.1429)	38154 P6035
3.36 (0.1323)	38154 P6026	3.66 (0.1441)	38154 P6036

C5 FINAL DRIVE

3. Final Drive Removal and Installation, Assembly and Disassembly (Cont'd)

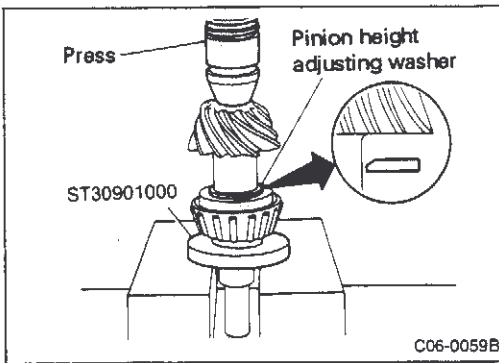

① Pinion bearing installation

- Using drift (special service tool), install pinion bearing.

CAUTION:

Make sure not to change washer direction.

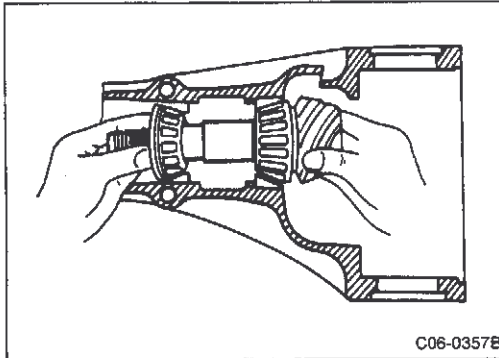

② Drive pinion and pinion bearing installation

- Coat bearing with gear oil.
- Assemble drive pinion and pinion bearing (front side) in carrier case.

CAUTION:

Do not assemble solid spacer and pinion bearing adjusting washer.

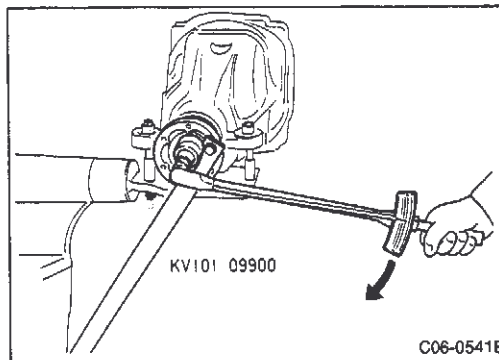

- Install companion flange.

CAUTION:

Do not install oil seal.

- Coat drive pinion threads and pinion nut seat with oil. Temporarily install pinion nut.
- Tighten pinion nut to standard preload.

Pinion bearing preload standard value:

1.0 - 1.6 N·m (0.10 - 0.16 kg·m, 0.7 - 1.2 ft·lb)

CAUTION:

Tighten pinion nut in 50 - 100 increments during measurement because it does not enter spacer. Do not tighten nut with excessive force.

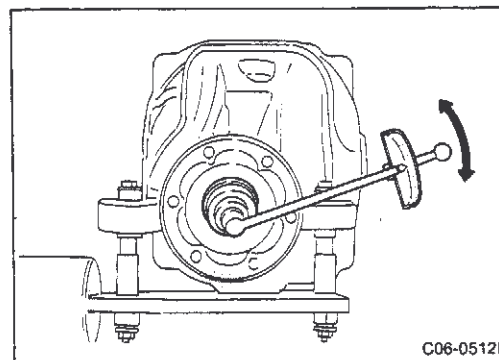

③ Differential case installation

- Coat bearing with gear oil.
- Assemble differential case assembly and side bearing outer race together in carrier case.

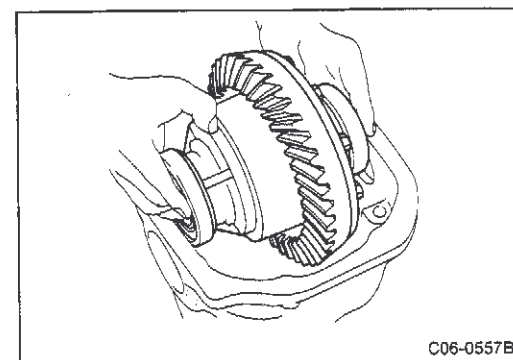

C5 FINAL DRIVE

3. Final Drive Removal and Installation, Assembly and Disassembly (Cont'd)

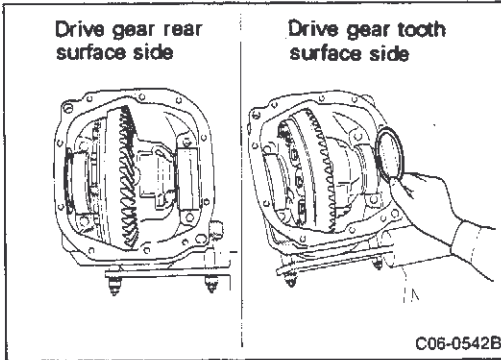

- Install drive gear rear surface side and tooth side washer.

CAUTION:

If washer that was removed is assembled again it must be the same thickness as it was before unit was disassembled. Do not confuse the rear side and gear side of washer.

- Install bearing between bearing outer race and adjusting washer.

CAUTION:

Use plastic hammer to tap rounded spacer surfaces lightly during assembly.

Spacer

Thickness mm (in)	Part number
8.1 (0.319)	38454 40P00

Spacer installation position: Drive gear rear side

- Align mating marks, assemble bearing cap and tighten bolts.

Tightening torque:

88 - 98 N·m (9 - 10 kg-m, 65 - 72 ft-lb)

④ **Gear tooth contact inspection**

- Clean drive gear teeth. Apply a light mixture of powdered titanium oxide and oil or equivalent to both sides of drive gear. Rotate drive pinion gear and drive pinion and check gear tooth contact pattern.

- Check gear tooth contact pattern in four locations on both surfaces of drive side (acceleration) and back side (deceleration) gears.

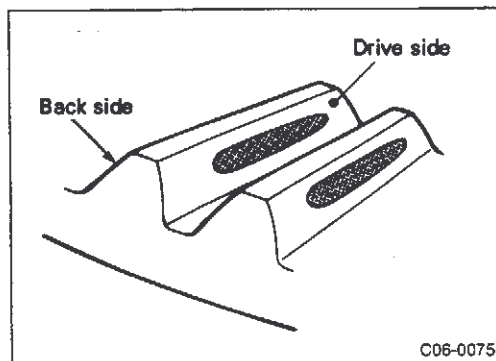
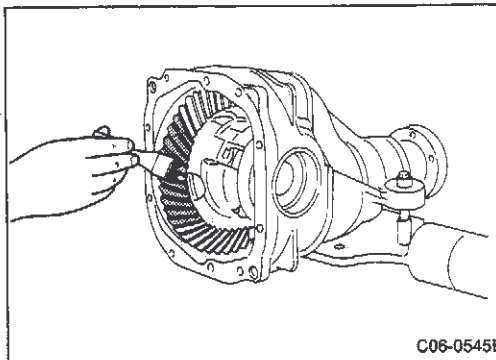
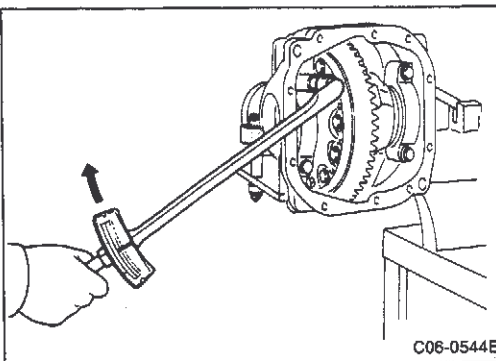
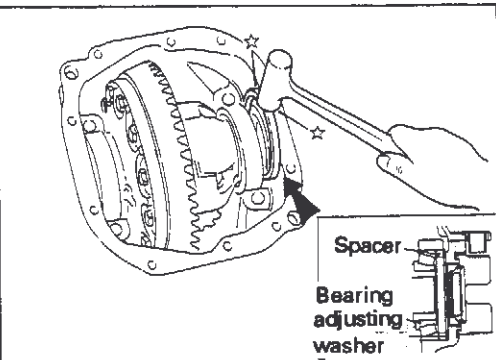

C5 FINAL DRIVE

3. Final Drive Removal and Installation, Assembly and Disassembly (Cont'd)

Gear tooth contact pattern chart

Contact pattern		Pinion height adjusting washer selection value mm (in)	Adjustment	Resulting problem
Drive side	Back side			
Heel side Toe side 	Toe side Heel side 	+0.09 (+0.0035)	Necessary	Cause noise and scoring sound at all speeds.
Heel side Toe side 	Toe side Heel side 	+0.06 (+0.0024)	↑	Causes noise during acceleration.
Heel side Toe side 	Toe side Heel side 	+0.03 (+0.0012)	Unnecessary	
Heel side Toe side 	Toe side Heel side 	0 (0)	↑	
Heel side Toe side 	Toe side Heel side 	-0.03 (-0.0012)	↑	
Heel side Toe side 	Toe side Heel side 	-0.06 (-0.0024)	Necessary	Causes noise at fixed speeds and during deceleration.
Heel side Toe side 	Toe side Heel side 	-0.09 (-0.0035)	↑	Makes noise and scoring sound at all speeds.

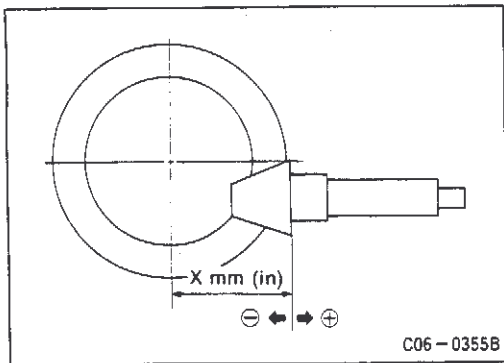

- If gear tooth contact pattern is incorrect, select pinion height adjusting washer of suitable thickness to adjust pinion height [X mm (in) figure.]

C5 FINAL DRIVE

3. Final Drive Removal and Installation, Assembly and Disassembly (Cont'd)

Pinion height adjusting washer

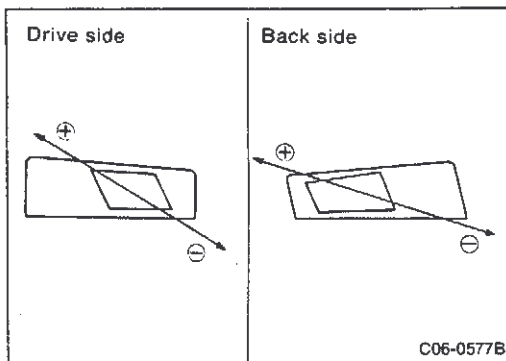

Thickness mm (in)	Part number	Thickness mm (in)	Part number
3.09 (0.1217)	38154 P6017	3.39 (0.1335)	38154 P6027
3.12 (0.1228)	38154 P6018	3.42 (0.1346)	38154 P6028
3.15 (0.1240)	38154 P6019	3.45 (0.1358)	38154 P6029
3.18 (0.1252)	38154 P6020	3.48 (0.1370)	38154 P6030
3.21 (0.1264)	38154 P6021	3.51 (0.1382)	38154 P6031
3.24 (0.1276)	38154 P6022	3.54 (0.1394)	38154 P6032
3.27 (0.1287)	38154 P6023	3.57 (0.1406)	38154 P6033
3.30 (0.1299)	38154 P6024	3.60 (0.1417)	38154 P6034
3.33 (0.1311)	38154 P6025	3.63 (0.1429)	38154 P6035
3.36 (0.1323)	38154 P6026	3.66 (0.1441)	38154 P6036

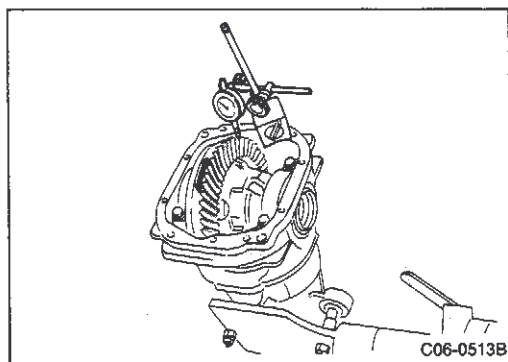

- Set dial gauge on drive gear surface and measure backlash.

Backlash standard value:

0.13 - 0.18 mm (0.0051 - 0.0071 in)

- If backlash is not within specification range, move side bearing adjusting washers of same thickness (carrier case side) to adjust.

Excessive backlash:	Use thicker drive gear rear side washer. Use thinner drive gear tooth side washer.
Insufficient backlash:	Use thinner drive gear rear side washer. Use thicker drive gear tooth side washer.

C5 FINAL DRIVE

3. Final Drive Removal and Installation, Assembly and Disassembly (Cont'd)

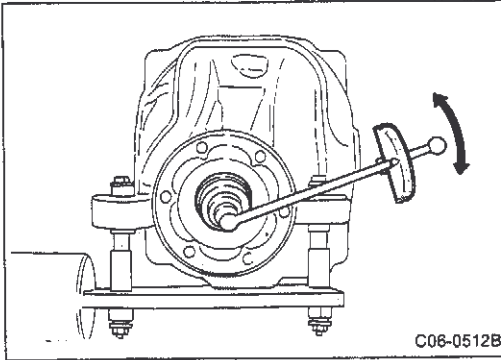

- Rotate companion flange more than 20 times. Measure total preload with preload gauge.

Side bearing preload standard value:

0.3 - 1.5 N·m (0.03 - 0.15 kg·m, 0.2 - 1.1 ft·lb)

Pinion bearing preload standard value:

1.8 - 2.6 N·m (0.18 - 0.27 kg·m, 1.3 - 2.0 ft·lb)

Total preload standard value (Without oil seal):

1.3 - 3.0 N·m (0.13 - 0.31, 0.9 - 2.2 ft·lb)

- If preload is not within specification range, move adjusting washers of same thickness on both sides to adjust preload.

Excessive preload:	Use thinner adjusting washer.
Insufficient preload:	Use thicker adjusting washer.

Side bearing adjusting washers

Thickness mm (in)	Part number	Thickness mm (in)	Part number	Thickness mm (in)	Part number
2.00 (0.0787)	38453 N3100	2.25 (0.0886)	38453 N3105	2.50 (0.0984)	38453 N3110
2.05 (0.0807)	38453 N3101	2.30 (0.0906)	38453 N3106	2.55 (0.1004)	38453 N3111
2.10 (0.0827)	38453 N3102	2.35 (0.0925)	38453 N3107	2.60 (0.1024)	38453 N3112
2.15 (0.0846)	38453 N3103	2.40 (0.0945)	38453 N3108	2.65 (0.1043)	38453 N3113
2.20 (0.0866)	38453 N3104	2.45 (0.0965)	38453 N3109		

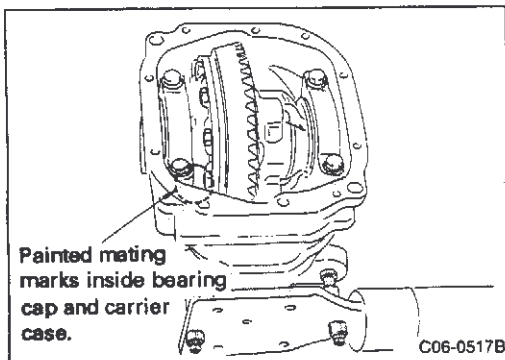

[Point 8] Drive pinion preload adjustment

Ⓐ Differential case assembly removal

- Remove bearing cap bolts. Tap bearing caps lightly with plastic hammer and remove.

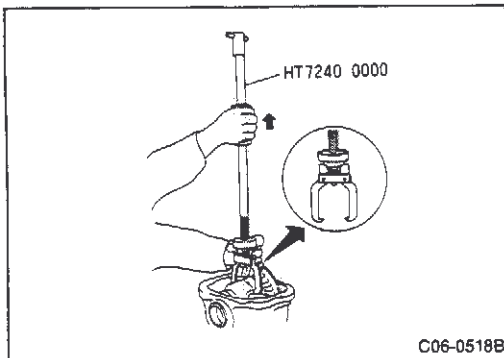

- Using sliding hammer (commercial service tool), separate differential case assembly and carrier case.

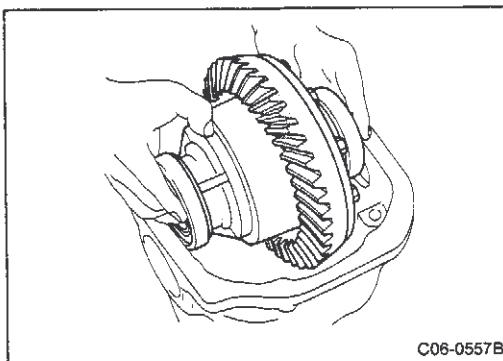

- Remove differential case assembly together with side bearing outer race.

C5 FINAL DRIVE

3. Final Drive Removal and Installation, Assembly and Disassembly (Cont'd)

- Carefully arrange bearing outer race, adjusting washers and spacers into separate groups of rear side and gear tooth side parts.

Gear ratio	Installation position
4.000 min.	Drive gear rear side

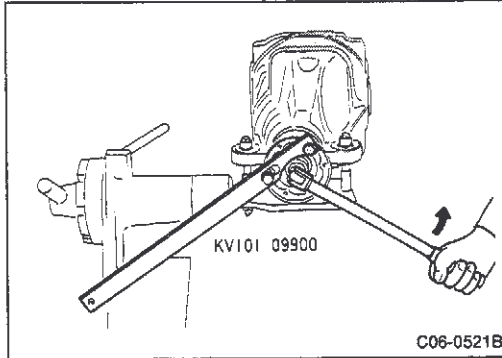
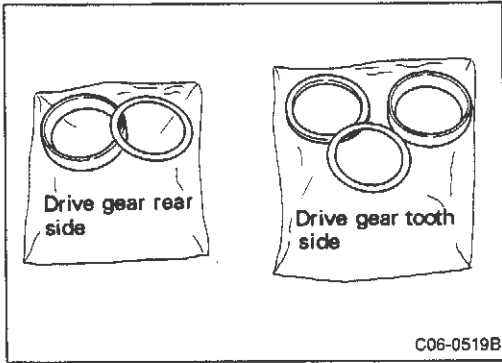

(b) Drive pinion assembly removal

- Using cam sprocket wrench (special service tool), remove pinion lock nut.

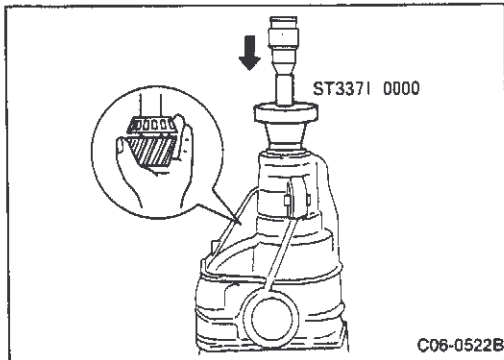

- Using drift (special service tool), remove drive pinion assembly.

CAUTION:

Do not let drive pinion fall.

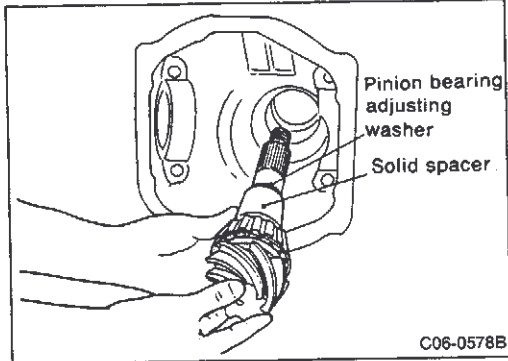

(c) Drive pinion assembly installation

- Install solid spacer and adjusting washer (which were used before disassembly) on drive pinion or spacer of same length and washer of same thickness that were originally used.

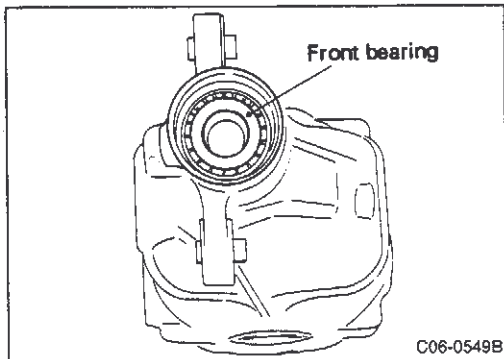

- Apply a light coat of oil to front bearing and install in carrier case.

C5 FINAL DRIVE

3. Final Drive Removal and Installation, Assembly and Disassembly (Cont'd)

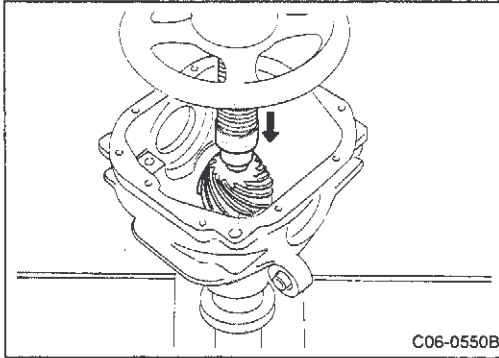

- Install drive pinion assembly with companion flange in carrier case.

CAUTION:

Do not assemble oil seal.

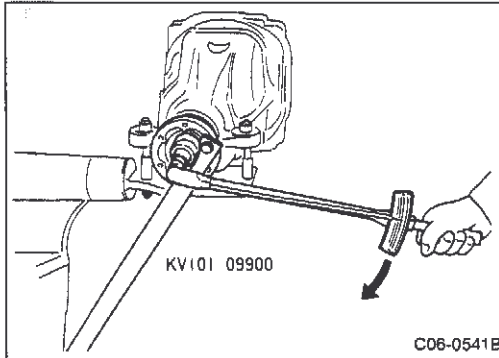

- Apply a light coat of oil to pinion nut seat and drive pinion threads and install nut.
- Rotate companion flange more than 20 times and make sure bearing spins smoothly.
- Tighten drive pinion nut while measuring preload using preload gauge.
- When specified torque is reached, select suitable spacer and washer to ensure specified pinion bearing preload is obtained.

Use longer spacer and thicker washer first, then change to shorter and thinner ones until specified preload is obtained.

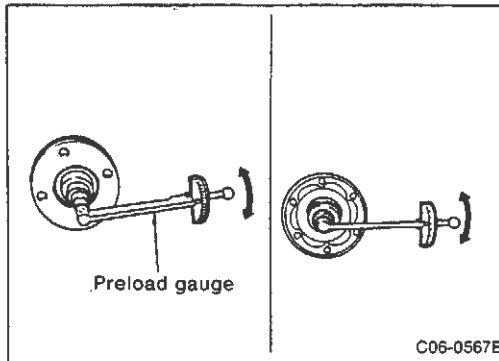

Drive pinion tightening torque:

186 - 294 N·m (19 - 30 kg·m, 137 - 217 ft·lb)

Specified pinion bearing preload (w/o oil seal):

1.0 - 1.6 N·m (0.10 - 0.16 kg·m, 0.7 - 1.2 ft·lb)

Excessive preload:	Use longer spacer and thicker washer
Insufficient preload:	Use shorter spacer and thinner washer

CAUTION:

Do not apply excess preload to pinion bearing.

Pinion bearing adjusting spacers

Thickness mm (in)	Part number	Thickness mm (in)	Part number	Thickness mm (in)	Part number
46.5 (1.831)	38165 10V00	45.6 (1.795)	38165 10V05	46.2 (1.819)	38165 10V07
46.8 (1.843)	38165 10V01	45.9 (1.807)	38165 10V06		

Pinion bearing adjusting washers

Thickness mm (in)	Part number	Thickness mm (in)	Part number	Thickness mm (in)	Part number
3.80 (0.1496)	38125 61001	3.90 (0.1535)	38130 61001	4.00 (0.1575)	38135 61001
3.82 (0.1504)	38126 61001	3.92 (0.1543)	38131 61001	4.02 (0.1583)	38136 61001
3.84 (0.1512)	38127 61001	3.94 (0.1551)	38132 61001	4.04 (0.1591)	38137 61001
3.86 (0.1520)	38128 61001	3.96 (0.1559)	38133 61001	4.06 (0.1598)	38138 61001
3.88 (0.1528)	38129 61001	3.98 (0.1567)	38134 61001	4.08 (0.1606)	38139 61001

C5 FINAL DRIVE

3. Final Drive Removal and Installation, Assembly and Disassembly (Cont'd)

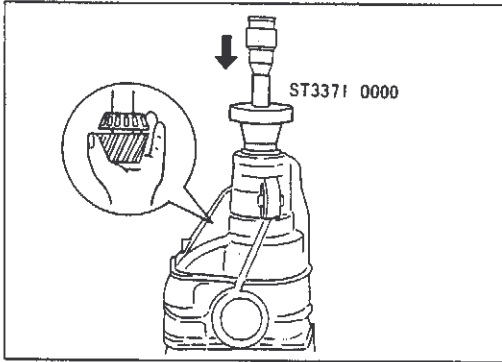

- When specified bearing preload is obtained at specified drive pinion torque (using solid spacer and adjusting washer), extract drive pinion.

CAUTION:

Be careful not to drop drive pinion.

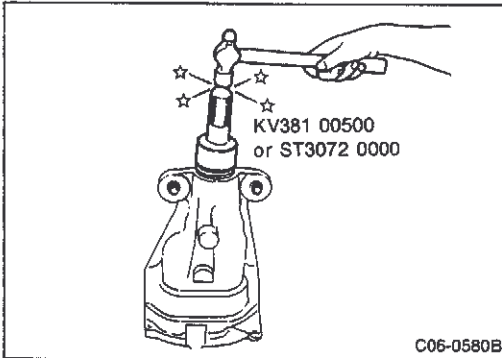

- Coat oil seal lip with Nissan MP special grease No. 2.
- Using drift (special service tool), install oil seal in carrier case.

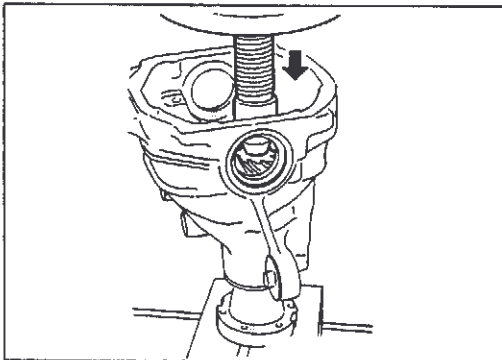

- Apply gear oil to pinion bearing.
- Install drive pinion assembly (with suitable spacer and adjusting washer installed) and companion flange in carrier case as a unit.

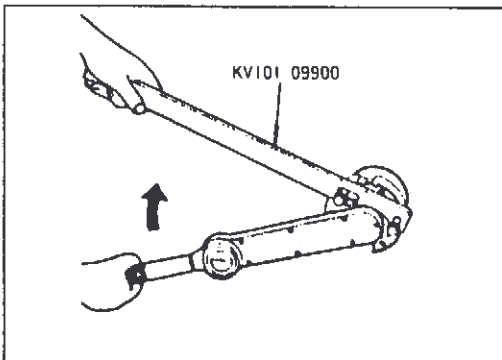

- Apply a coat of rust-preventive oil to drive pinion threads and pinion nut seat.

CAUTION:

Discard old pinion nut; replace with new one.

- Rotate companion flange more than 20 times until it wears in.
- Tighten drive pinion to specifications.

Drive pinion tightening torque:

186 - 294 N·m (19 - 30 kg-m, 137 - 217 ft-lb)

CAUTION:

Do not tighten drive pinion excessively.

- Measure preload with preload gauge.

Pinion bearing standard preload (w/oil seal) :

1.1 - 1.7 N·m (0.11 - 0.17 kg-m, 0.8 - 1.2 ft-lb)

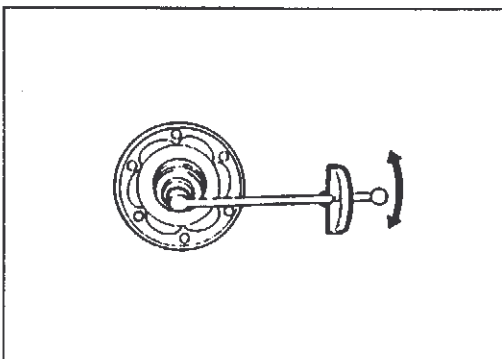

C5 FINAL DRIVE

3. Final Drive Removal and Installation, Assembly and Disassembly (Cont'd)

[Point 9] Differential case assembly installation

- Coat bearing with gear oil.
- Install differential case assembly together with bearing outer race in carrier case.

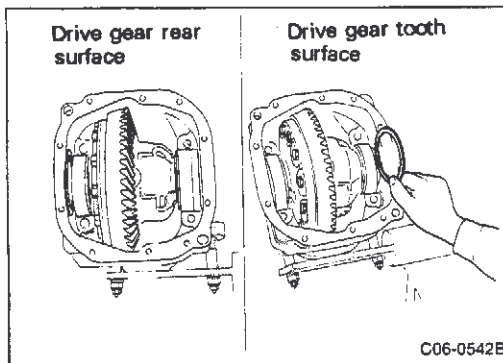
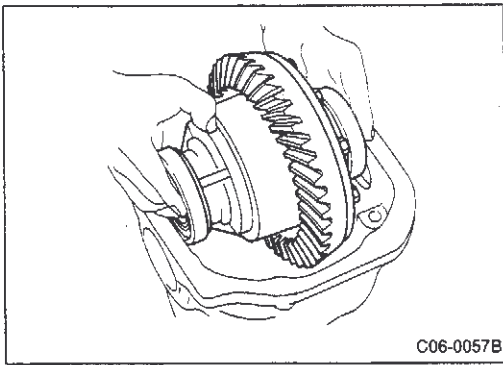

- Install drive gear rear side and tooth side selected washers.

CAUTION:

Do not interchange rear and tooth side washers by mistake.

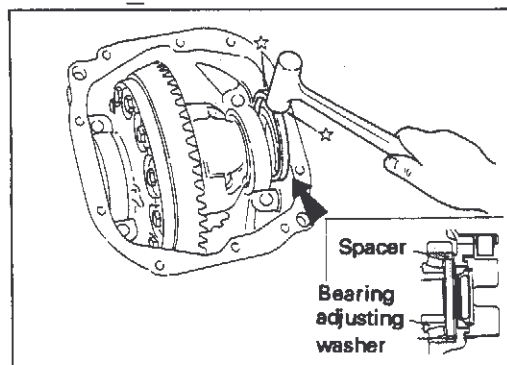

- Install spacer between bearing outer race and adjusting washer.

CAUTION:

Use plastic hammer and tap outside of spacer evenly to install.

Spacer

Thickness mm (in)	Part number
8.1 (0.319)	38454 N3100

Spacer installation position: Drive gear rear side

- Align mating marks, install bearing cap and tighten bolts.

Tightening torque:

88 - 98 N·m (9 - 10 kg·m, 65 - 72 ft·lb)

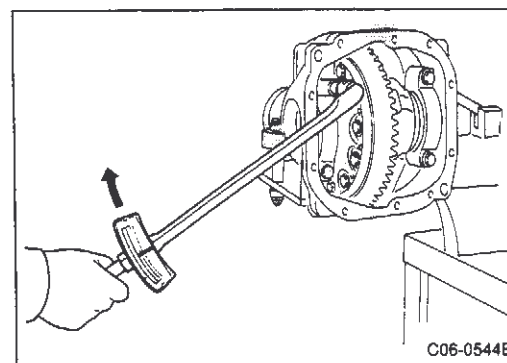

C5 FINAL DRIVE

3. Final Drive Removal and Installation, Assembly and Disassembly (Cont'd)

[Point 10] Inspection after assembly

Ⓐ Total preload inspection

- Turn companion flange more than 20 times. Use preload gauge and measure total preload.

Side bearing preload standard value:

0.3 - 1.5 N·m (0.03 - 0.15 kg-m, 0.2 - 1.1 ft-lb)

Pinion bearing preload standard value (without oil seal):

1.1 - 1.7 N·m (0.11 - 0.17 kg-m, 0.8 - 1.2 ft-lb)

Total preload standard value:

1.4 - 3.1 N·m (0.14 - 0.32 kg-m, 1.0 - 2.3 ft-lb)

- If torque preload is not within the specification range, move side bearing adjusting washers of same thickness on both sides to adjust preload.

Excess preload:	● Use thinner side bearing washer.
Insufficient preload:	● Use thicker side bearing washer.

Ⓑ Hypoid gear and backlash inspection

- Position dial gauge on drive gear surface and measure backlash.

Backlash standard value:

0.13 - 0.18 mm (0.0051 - 0.0071 in)

- If backlash is not within the specification range, adjust by increasing or decreasing side bearing washer thickness the same amount on both sides.

Excess backlash:	● Use thicker drive gear rear side washer and thinner drive gear tooth side washer.
Insufficient backlash:	● Use thinner drive gear rear side washer and thicker drive gear tooth side washer.

Ⓒ Drive gear rear surface runout inspection

- Place dial gauge on rear surface of drive gear. Turn drive gear and measure runout.

Runout limit:

0.05 mm (0.0020 in) max.

- If runout exceeds limit, check drive gear assembly condition (foreign matter jammed between drive gear and differential case, deformation of differential case, etc.).
- If drive gear is faulty, replace hypoid gear assembly. If differential case is deformed, replace case.

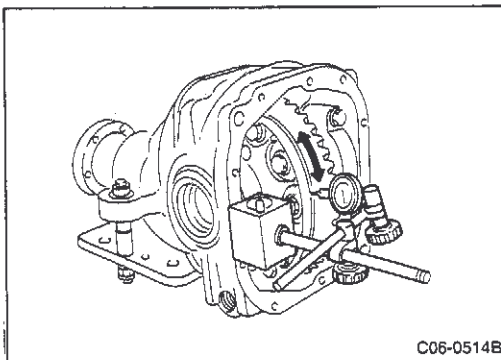
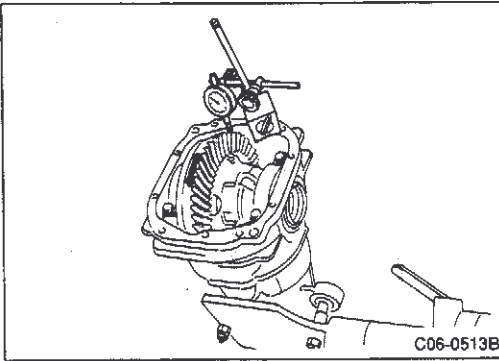
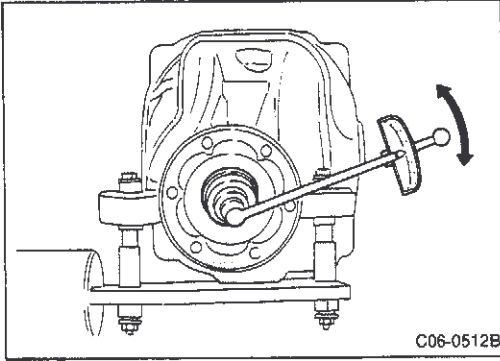

C5 FINAL DRIVE

3. Final Drive Removal and Installation, Assembly and Disassembly (Cont'd)

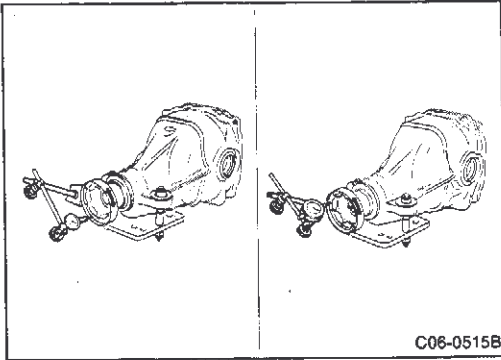

① Companion flange runout inspection

- Place dial gauge on companion flange (propeller shaft installation surface) and measure runout.

Runout limit:

0.05 mm (0.0020 in) max.

- Set test indicator inside companion flange (inner lower surface) and measure runout.
- Place paint mark on maximum outward runout of companion flange.

Runout limit:

0.05 mm (0.0020 in) max.

CAUTION:

- (1) If measurement surface is rusted, remove rust before measurement.
 - (2) Make sure old paint is cleaned away before placing new mark.
- If runout exceeds specification limit, rotate relative positions of companion flange and drive pinion 90° and check if runout decreases.
 - If runout still is not within specification range even if the relative position is changed, replace companion flange.
 - If companion flange is replaced and runout is still not within specification range, the problem may be due to poor contact between pinion bearing and drive pinion or faulty pinion bearing.

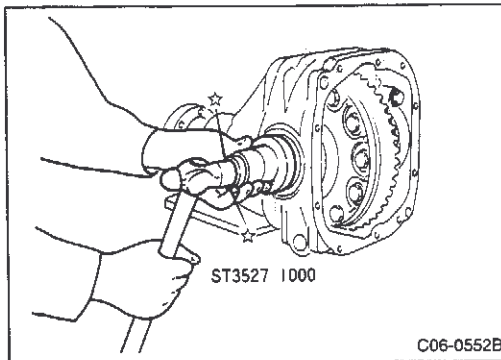

[Point 11] Side oil seal installation

- Coat oil seal lip with Nissan MP special grease No. 2.
- Using drift (special service tool), install oil seal in carrier case.

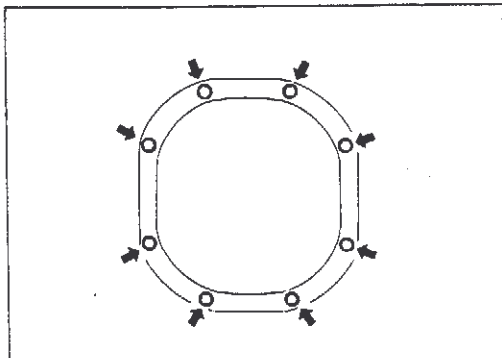

[Point 12] Installation of carrier case cover, drain plug and filler plug

- Install carrier case cover with gasket in place.
Tightening torque:
39 - 49 N·m (4 - 5 kg-m, 29 - 36 ft-lb)
- Apply liquid gasket (Three Bond 1215 or equivalent) to drain and filler plugs and install plugs.
Drain plug tightening torque:
59 - 98 N·m (6 - 10 kg-m, 43 - 72 ft-lb)
Filler plug tightening torque:
59 - 98 N·m (6 - 10 kg-m, 43 - 72 ft-lb)

C5 FINAL DRIVE

3. Final Drive Removal and Installation, Assembly and Disassembly (Cont'd)

(2) Front final drive side shaft assembly and disassembly

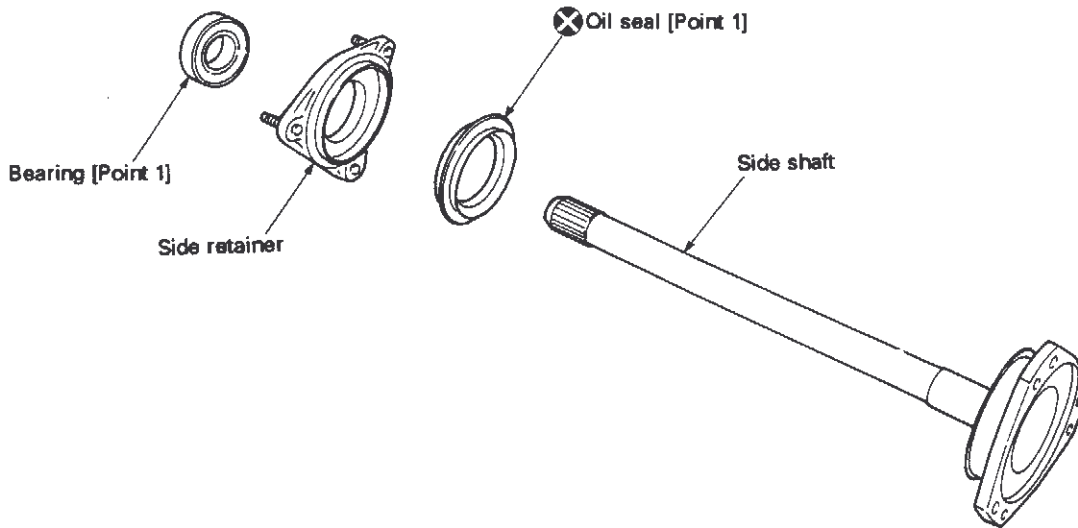

⊗: Always replace after every disassembly.

C06-0419B

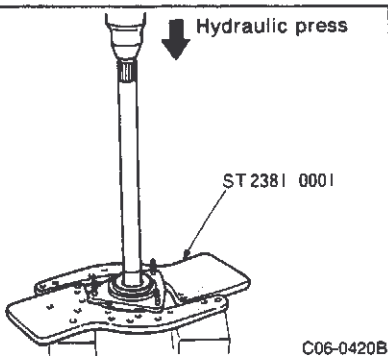

[Point 1] Side shaft bearing and oil seal removal and installation

Removal

- Using two adapter setting plates and hydraulic press as shown in left figure, separate side retainer and side shaft.

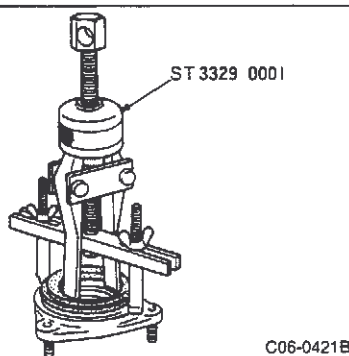

- Using oil seal puller (special service tool), remove oil seal.

CAUTION:

Always replace oil seal after every disassembly.

C5 FINAL DRIVE

3. Final Drive Removal and Installation, Assembly and Disassembly (Cont'd)

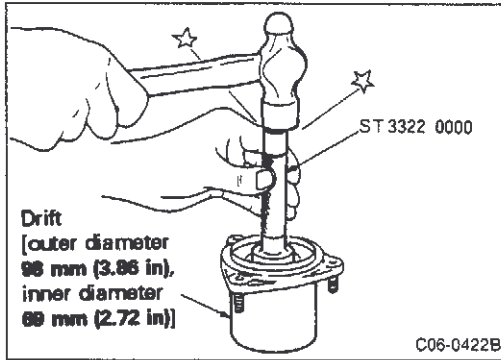

- Place drift [outer diameter 98 mm (3.86 in), inner diameter 69 mm (2.72 in)] on bottom side and remove bearing with drift (special service tool) [outer diameter 32 mm (1.26 in)].

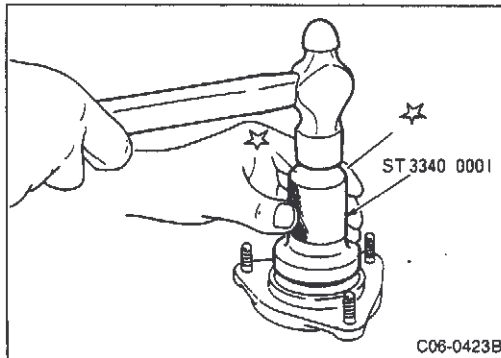

Installation

- Use drift (special service tool) as shown in figure, and press-fit bearing until it is even with lower surface of side retainer.

CAUTION:
Do not install bearing at angle.

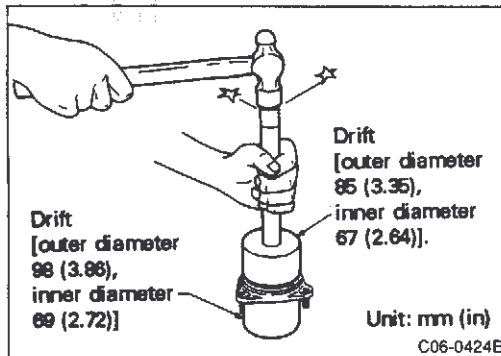

- Place drift [outer diameter 98 mm (3.86 in), inner diameter 69 mm (2.72 in)] on bottom and use drift [outer diameter 85 mm (3.35 in), inner diameter 67 mm (2.64 in)] to press-fit oil seal even with side retainer.

CAUTION:
(1) Do not install oil seal at an inclined angle.
(2) Apply MP special grease No. 2 to oil seal lip sliding surface.

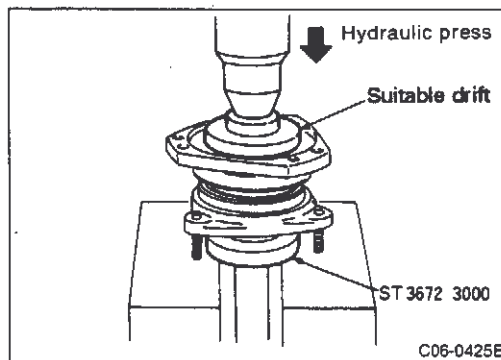



- Place suitable drift (special service tool) against side shaft and press-fit shaft on retainer.

C6 DRIVE SHAFT

OPERATION PRECAUTIONS

- Use torque wrench to tighten nuts and bolts.

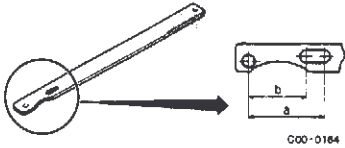
Tools required

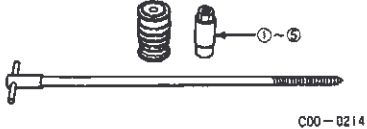
	Name	Description	Application	Remarks
Special service tool	Flange wrench KV401 04000	 C00-0164	Wheel hub lock nut removal and installation	Already described
Regular tools	Pitman arm puller HT7256 0000	 C00-0231	Side rod removal	Nis-salco
	Drive shaft joint puller HT7255 Attachment HT7255 1000 ① M20 x 1.0 ② M20 x 1.5 ③ M22 x 1.0 ④ M22 x 1.5 ⑤ M24 x 1.5	 C00-0214	Fixed joint removal	
Note: The sliding hammer gear puller HT7240 that was previously described can be used for the drive shaft joint puller slide hammer.				

1. Summary

Specifications

Item	Location		Front	Rear
	Final drive type		F160	R200 mechanical LSD (RB26DETT)
Model number			Z80T70C (right) Z80T82F (left)	B100D100
Middle tube diameter	mm (in)	Right	25 (0.98)	30 (1.18)
		Left	25 (0.98)	30 (1.18)
Dimension between joint L	mm (in)	Right	323 (12.72)	440 (17.32)
		Left	408 (16.06)	398 (15.67)
Maximum length M	mm (in)	Right	448.1 (17.64)	561.1 (22.09)
		Left	513.7 (20.22)	519.1 (20.44)
Differential insertion length ℓ	mm (in)	Right	90 (3.54)	93 (3.66)
		Left	—	101 (3.98)

C6 DRIVE SHAFT

1. Summary (Cont'd)

Inspection specifications

Description		Location	Front		Rear
		Model number	Z80T70C (right)	Z80T82F (left)	B100D100
Grease quantity	g (oz)	Wheel hub joint	Approx. 120 (4.23)		Approx. 180 (6.35)
		Final drive joint	Approx. 190 (6.70)	Approx. 155 (5.47)	Approx. 190 (6.70)
Boot installation length		Wheel hub joint	90.5 - 92.5 (3.563 - 3.642)		102 (4.02)
	mm (in)	Final drive joint	95.5 - 97.5 (3.760 - 3.839)	95 - 97 (3.74 - 3.82)	103.5 (4.07)
Drive shaft installation bolt tightening torque			—	27 - 37 (2.8 - 3.8, 20 - 27)	83 - 93 (8.5 - 9.5, 61 - 69)
		N-m (kg-m, ft-lb)			
Axial play (wheel hub joint)		mm (in)	1 (0.04) max.		

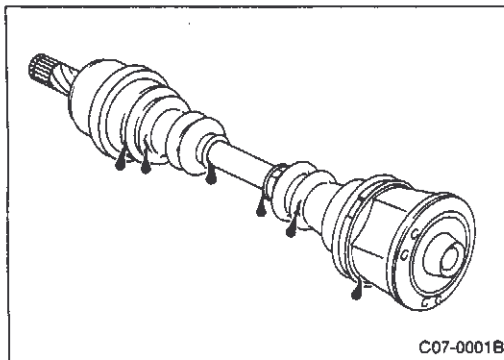

2. On-vehicle Inspection

Check boot and drive shaft for damage, wear and grease leaks.

- Check boot and drive shaft for damage, wear and grease leaks. Replace parts as necessary.

C6 DRIVE SHAFT

3. Drive Shaft Removal and Installation, Assembly and Disassembly

3-1 REMOVAL AND INSTALLATION

(1) Front drive shaft

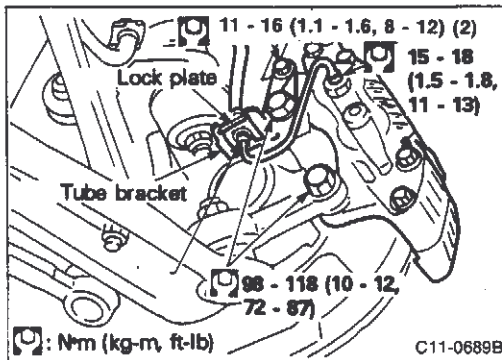
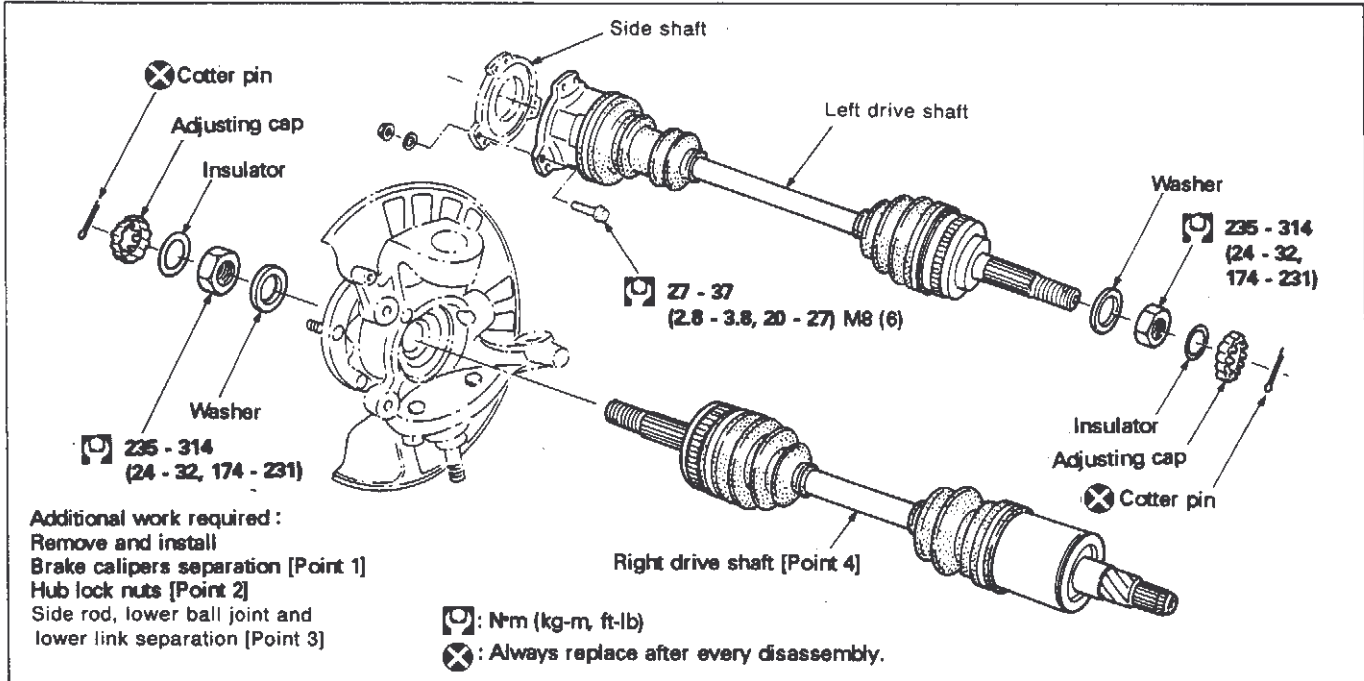

[Point 1] Brake caliper assembly separation

- Remove brake hose bracket lock plate and separate brake hose. Remove caliper assembly from disk rotor and attach to strut.

CAUTION:

Do not damage brake hose.

[Point 2] Hub lock nut removal and installation

Removal

- Using hub lock nut wrench (special service tool), lock hub and loosen front hub lock nut.

Installation

- Install drive shaft and hub assembly in vehicle. Tighten lock nut to torque indicated below.

Tightening torque:

235 - 314 N·m (24 - 32 kg-m, 174 - 231 ft-lb)

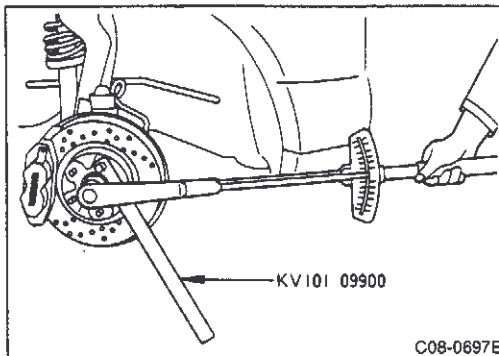

C6 DRIVE SHAFT

3. Drive shaft Removal and Installation, Assembly and Disassembly (Cont'd)

[Point 3] Tie-rod, suspension lower ball joint and lower link separation

- Using Pitman arm puller (commercial service tool), separate tie-rod and suspension lower ball joint.

CAUTION:

Be careful when removing ball joint because the knuckle is made of aluminum and scratches easily. Use Pitman arm puller and do not tap knuckle.

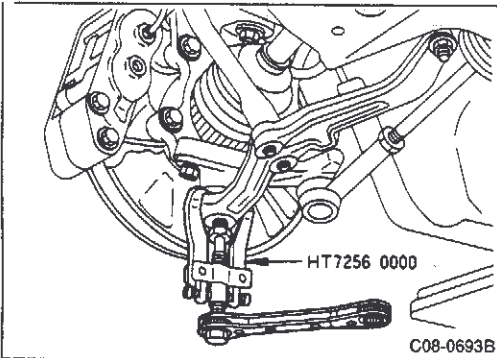
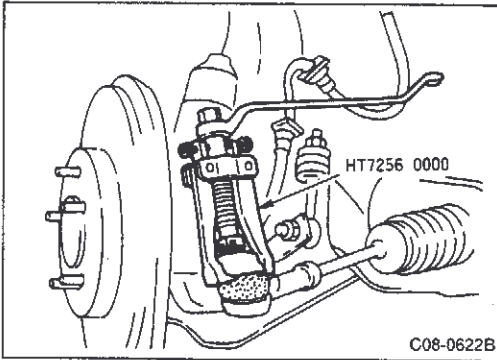

- Using Pitman arm puller (commercial service tool), separate suspension lower ball joint and lower link.

[Point 4] Right drive shaft removal and installation

Removal

- Drain oil from front final drive and remove rear cover. Use wheel wrench as lever and remove shaft.

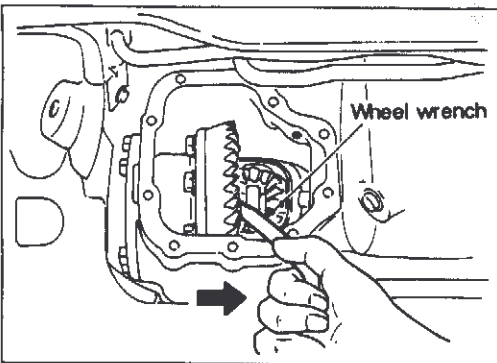

Installation

- Insert drive shaft in final drive. Apply silicon bond sealant TB1215 (KP210 00200) to rear cover sealing surfaces.

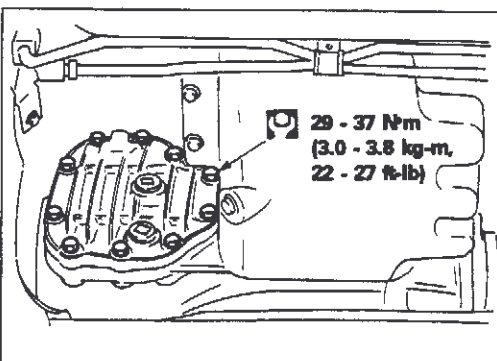
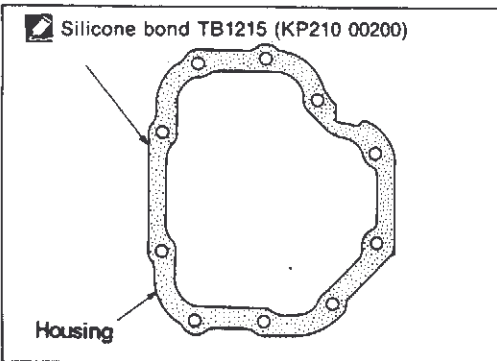

- Tighten differential cover to specified torque.
Differential cover tightening torque:
29 - 37 N·m (3.0 - 3.8 kg-m, 22 - 27 ft-lb)
- Fill oil from filler plug hole. Use Nissan gear oil hypoid GL-5 85W90.

C6 DRIVE SHAFT

3. Drive shaft Removal and Installation, Assembly and Disassembly (Cont'd)

(2) Rear drive shaft

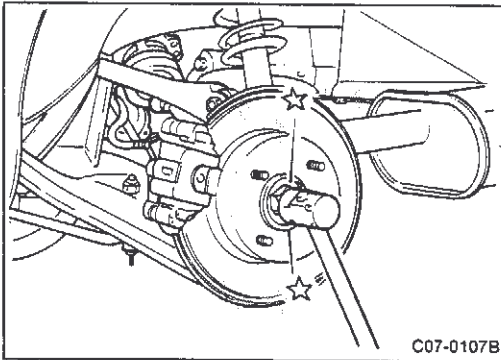
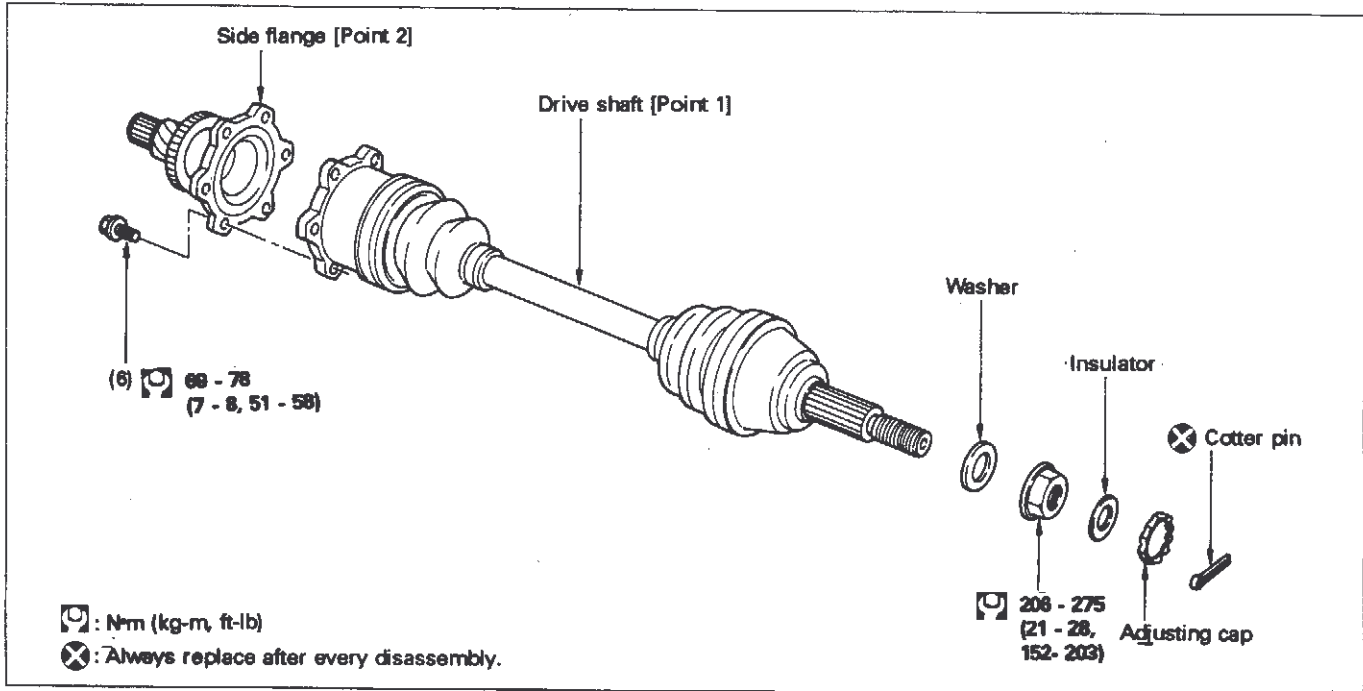

[Point 1] Drive shaft removal and installation

Removal

- Remove side flange bolts and separate drive shaft.
- Tap drive shaft with copper hammer as shown in figure and remove.

CAUTION:

Attach nut to prevent drive shaft threads from being damaged.

Installation

- Insert drive shaft in wheel hub side and temporarily tighten hub lock nuts.
- Tighten side flange bolts to specified torque.
- Tighten hub lock nut to specified torque.

C6 DRIVE SHAFT

3. Drive shaft Removal and Installation, Assembly and Disassembly (Cont'd)

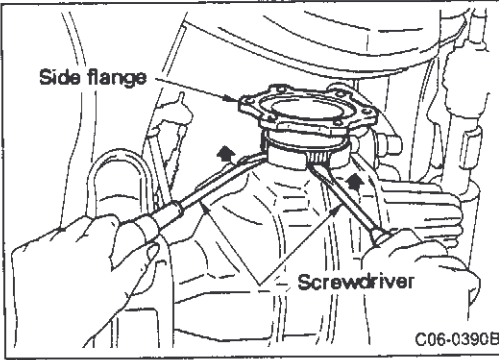

[Point 2] Side flange removal

- Use screwdriver as lever as shown in figure and remove circlip.
- Circlip installation position

F160 model	Right	Final drive side
	Left	None
R200 (mechanical LSD)	Right	Final drive side
	Left	Final drive side

3-2 ASSEMBLY AND DISASSEMBLY

Front drive shaft (Models Z80T70C, Z80T82F)

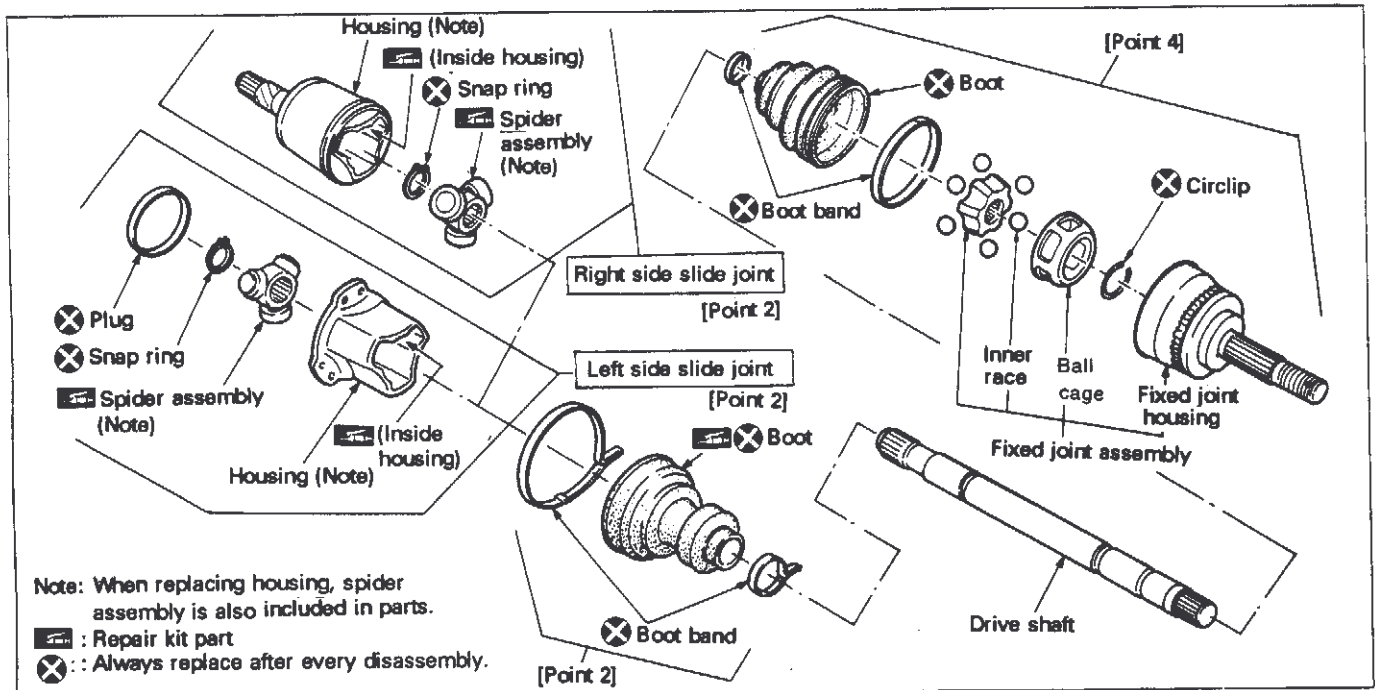

C6 DRIVE SHAFT

3. Drive shaft Removal and Installation, Assembly and Disassembly (Cont'd)

Rear drive shaft (Model B100D100)

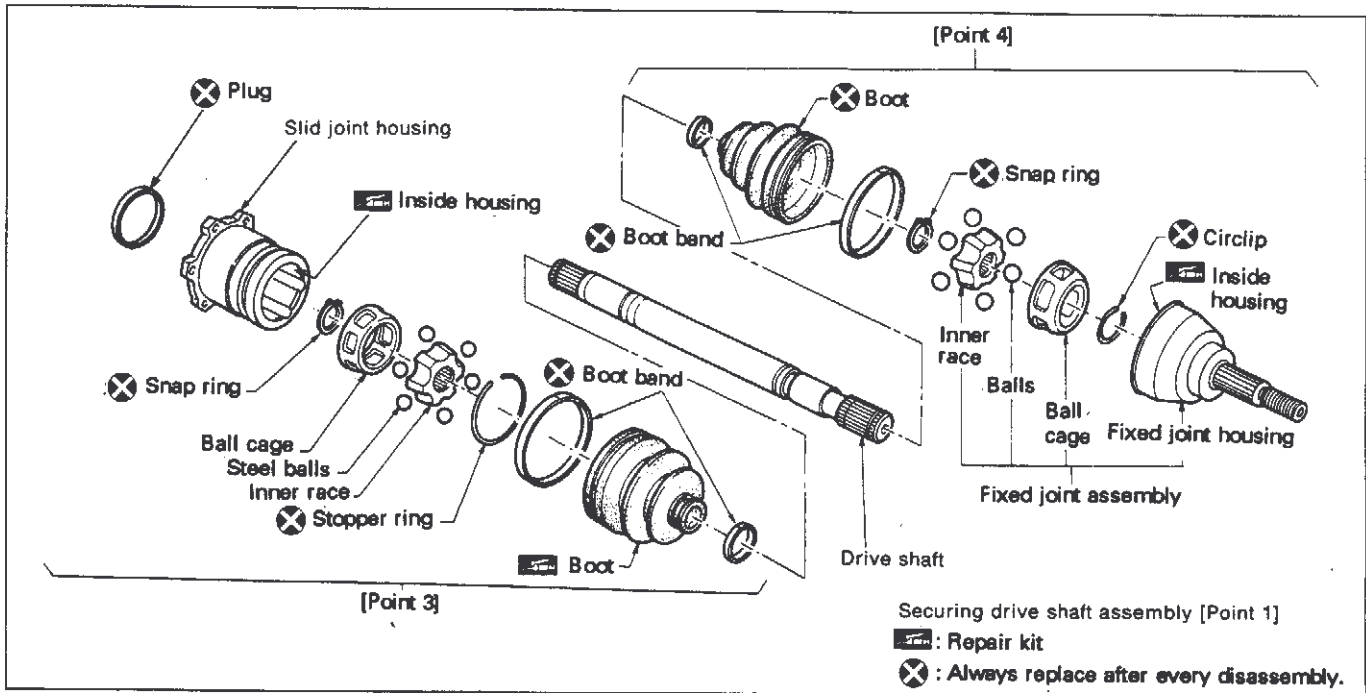

[Point 1] Securing drive shaft assembly

- Protect drive shaft with copper or aluminum plates and secure in vise.

CAUTION:

Tighten vise lightly because boots may be deformed if vise is tightened excessively.

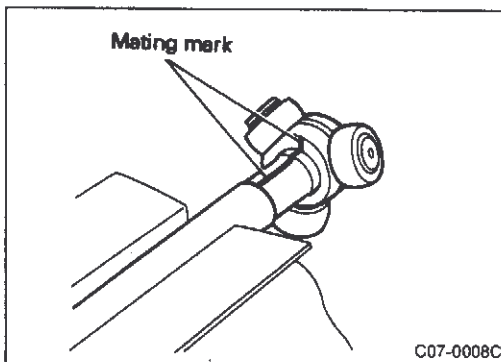

[Point 2] Slide joint assembly and disassembly (Models Z80T70C and Z80T82F)

Disassembly

- Remove boot and pull out shaft.

CAUTION:

Always replace boot after every disassembly.

- Inscribe mating marks on drive shaft and spider assembly
- Remove snap ring and detach spider assembly from drive shaft.
- Remove boot assembly from drive shaft.

CAUTION:

Spider assembly cannot be disassembled.

C6 DRIVE SHAFT

3. Drive shaft Removal and Installation, Assembly and Disassembly (Cont'd)

Part inspection

Part name	Inspection and operation
Shaft	<ul style="list-style-type: none"> ● Check drive shaft for runout, cracks and damage. Replace if necessary.
Housing	<ul style="list-style-type: none"> ● If housing roller surface is scratched or worn, check entire spider assembly. Replace housing and spider assembly as set if necessary.
Spider assembly	<ul style="list-style-type: none"> ● If rollers are pitted or scored in rotation direction, replace spider assembly. ● If serrated parts are deformed or scored, also inspect drive shaft. If worn or damaged, replace both spider assembly and drive shaft. ● If rollers are scratched or worn, inspect housing. If worn or damaged, replace both spider assembly and housing.
Boot and band	<ul style="list-style-type: none"> ● Replace if cracked. <p>CAUTION: After removing boot band, always replace with new part.</p>
Other	<ul style="list-style-type: none"> ● Replace if deformed or damaged.

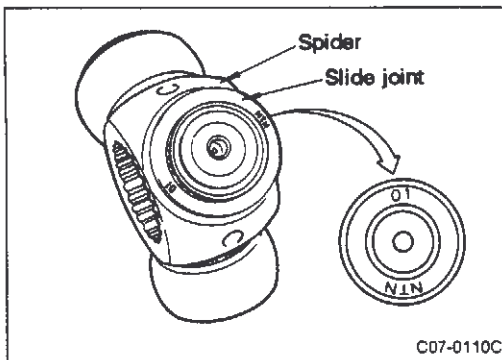

Assembly

- When replacing only spider assembly, select part with same identification number inscribed on slide joint as indicated in following charts. After selecting correct part, assemble unit.

CAUTION:

When replacing housing, replace as set with spider assembly.

Z80T70C (Right side)

Identification mark	Part number
01	39720 51E01
02	39720 51E02
03	39720 51E03

Z80T82F (Left side)

Identification mark	Part number
10	39720 10V10
11	39720 10V11
12	39720 10V12

C6 DRIVE SHAFT

3. Drive shaft Removal and Installation, Assembly and Disassembly (Cont'd)

- When installing spider assembly, align mating marks and install shaft.
- Secure spider assembly with snap ring.

CAUTION:

(1) Before installing spider assembly, mount boot on shaft.

(2) Position insertion direction as shown in figure.

- Apply repair kit grease to spider and sliding parts. Insert parts in housing and apply remaining grease in quantities indicated below.

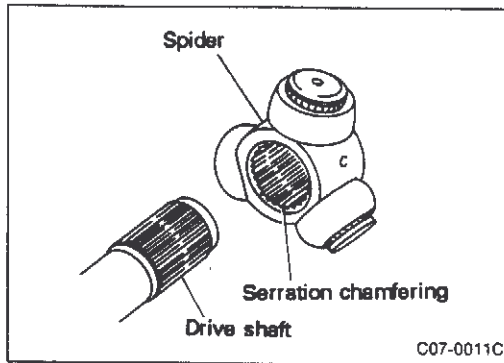

Model	Grease quantity g (oz)
Z80T70C	Approx. 190 (6.70)
Z80T82F	Approx. 155 (5.47)

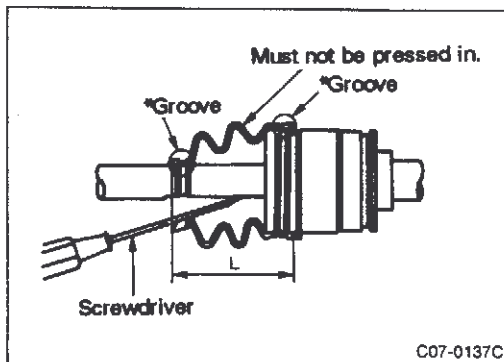

- Install boot securely in grooves (parts indicated by *) as shown in figure.
- Set boot length (L) as indicated below. Insert screwdriver in small diameter side, adjust inner and outer pressure of boot to avoid deformation.

CAUTION:

(1) If boot installation length is shorter than indicated below it may cause boot to break or split.

(2) Be careful not to touch the inside surface of boot with end of screwdriver.

Model	Installation length L mm (in)
Z80T70C	95.5 - 97.5 (3.760 - 3.839)
Z80T82F	95 - 97 (3.74 - 3.82)

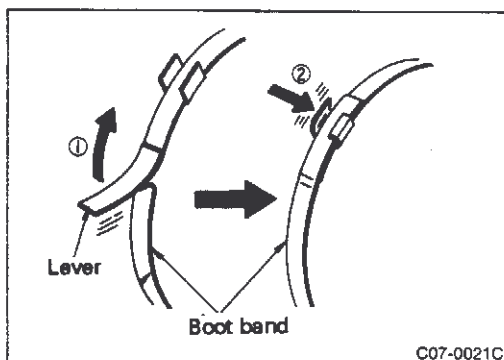

- Secure boot band on large and small diameter side of boot.

CAUTION:

Rotate joint and make sure boot installation position does not change. If position moves, install new boot band.

C6 DRIVE SHAFT

3. Drive shaft Removal and Installation, Assembly and Disassembly (Cont'd)

[Point 3] Slide joint assembly and disassembly (Model B100D100)

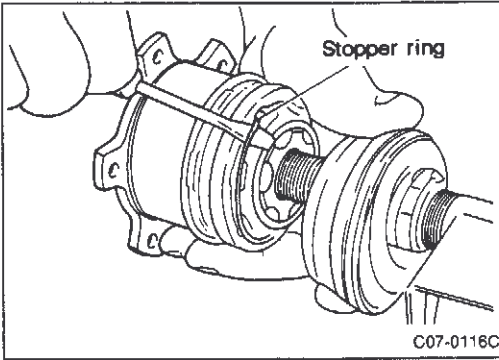

CAUTION:

Replace joint assembly if parts are worn or damaged.

Disassembly

- Remove boot band.

CAUTION:

Always replace boot band with new part after disassembly.

- Remove stopper ring and remove slide joint housing.

CAUTION:

- (1) Always replace stopper ring with new part after disassembly.
- (2) Stopper ring is used for slide stopper. Remove ring before removing slide joint housing.

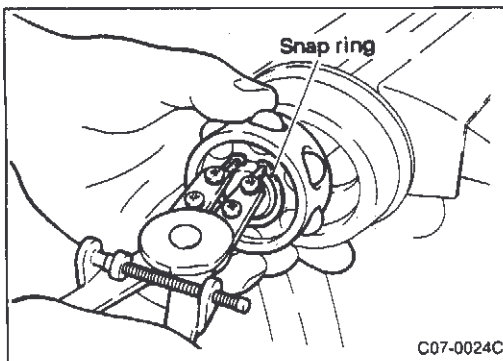

- Remove snap ring and detach ball cage and steel ball assembly.
- Remove boot.

CAUTION:

If boot is cracked and foreign matter is mixed with grease inside, disassemble and inspect ball cage and steel ball assembly.

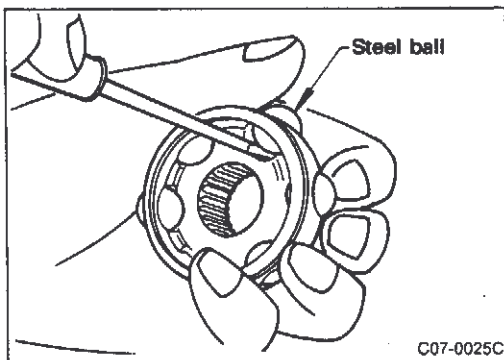

The ball cage and steel ball assembly should only be disassembled to clean the grease. If the steel balls or other parts are worn or damaged, replace joint assembly.

- Use screwdriver to remove steel balls one at a time.
- Remove inner race from large side of ball cage.

CAUTION:

When removing steel balls, do not scratch surface of steel balls and inner race contact surface.

C6 DRIVE SHAFT

3. Drive shaft Removal and Installation, Assembly and Disassembly (Cont'd)

Disassembly inspection

- Clean parts and inspect following items.

Part name	Inspection and operation
Shaft	<ul style="list-style-type: none"> ● Check shaft for runout, cracks and damage. ● Check threads for damage.
Joint assembly	<ul style="list-style-type: none"> ● Check joint rotation and abnormal play in axial direction. ● Check foreign matter inside joint.
Outer race	<ul style="list-style-type: none"> ● Check ball contact surface damage or abnormal wear. ● Check for deformation of boot installation.
Ball cage	<ul style="list-style-type: none"> ● Check for damage or abnormal wear in sliding parts.
Steel ball	<ul style="list-style-type: none"> ● Check for damage or abnormal wear.
Inner race	<ul style="list-style-type: none"> ● Check ball contact surface for scratches or abnormal wear. ● Check for damage in serration holes. (Check shaft serration holes at same time.)

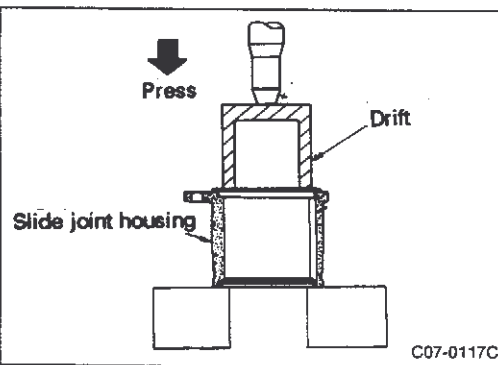

Assembly

- Using drift [outer diameter 78 mm (3.07 in), inner diameter 72 mm (2.83 in)], press-fit plug.
- Insert inner race in large diameter side of ball cage.
- Apply grease to cage pocket and assemble 6 balls in cage. At this time, rotate inserted cage one-half pitch (one-half the width of one drive shaft spline) to position inner race on axis correctly and then install.

CAUTION:

The inner race can be installed in either direction.

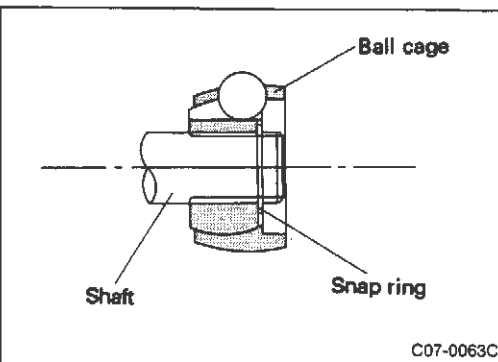

- Install new boot on shaft. Install ball cage and steel ball assembly.

CAUTION:

- (1) Install boot on shaft before assembling steel ball assembly.
- (2) The ball cage installation direction is shown in figure. Be careful to position cage in correct direction.

- Secure ball cage and steel ball assembly with snap ring.

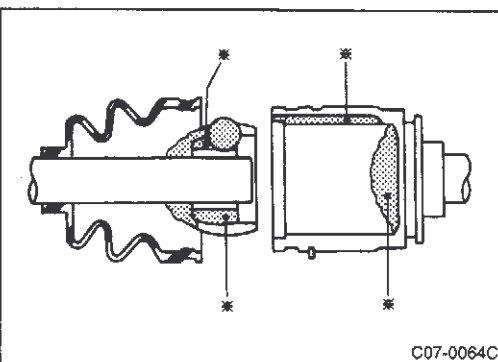

- Apply repair kit grease to slide joint housing (* part) in quantity indicated below.

Grease quantity:

190 g (6.70 oz)

C6 DRIVE SHAFT

3. Drive shaft Removal and Installation, Assembly and Disassembly (Cont'd)

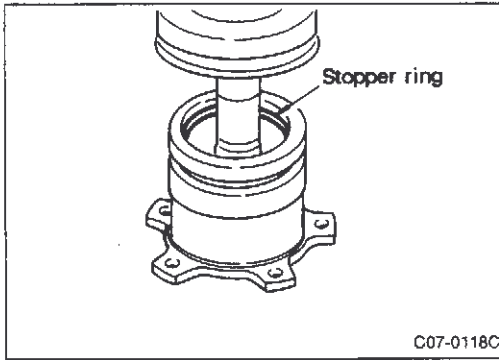

- Install stopper ring in slide joint housing.

CAUTION:

After installation, pull shaft out and make sure slide joint assembly and stopper ring engage correctly.

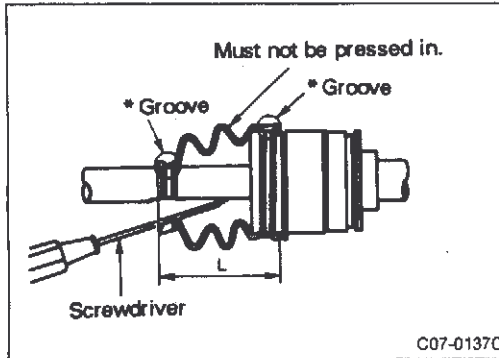

- Install boot securely in grooves (parts indicated by *) as shown in figure.

CAUTION:

Remove grease attached to boot installation surface (parts indicated by * in figure). Grease on surface may cause boot to slip off.

- Set boot length (L) as indicated below. Insert screwdriver in small diameter side, adjust inner and outer pressure of boot to avoid deformation.

CAUTION:

- (1) If boot installation length is shorter than dimension indicated below it may cause boot to break or split.
- (2) Be careful not to touch the inside surface of boot with end of screwdriver.

Installation length L:

103.5 mm (4.07 in)

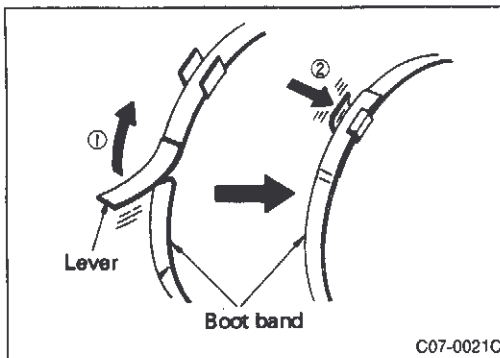

- Secure large and small side of boot with new boot band.

CAUTION:

Rotate joint and make sure boot installation position does not change. If position moves, install boot band one more time.

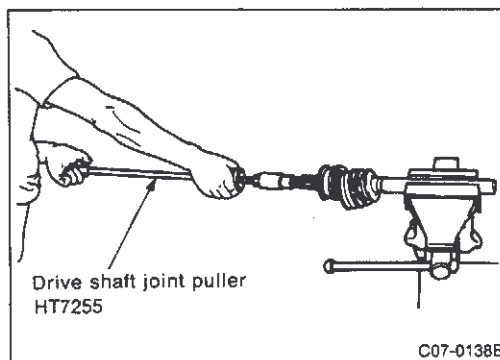

[Point 4] Fixed joint assembly and disassembly (Models Z80T70C, Z80T82F, B100D100)

CAUTION:

Replace joint assembly if parts are worn or damaged.

Disassembly

- Remove boot band and remove boot from housing.
- Using drive shaft joint puller, remove housing assembly from shaft.

C6 DRIVE SHAFT

3. Drive shaft Removal and Installation, Assembly and Disassembly (Cont'd)

CAUTION:

- (1) Screw drive shaft joint puller more than 30 mm (1.18 in) into housing threads.
- (2) If removal of housing assembly has been attempted more than five times and assembly cannot be detached, replace drive shaft assembly.

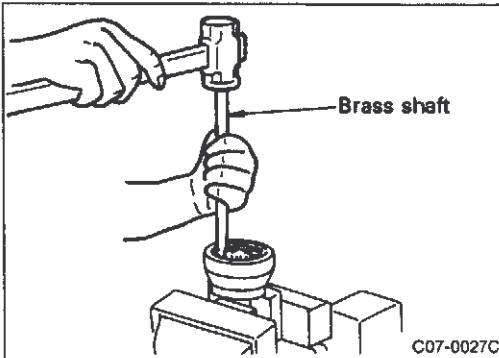

- Remove circlip and snap ring from shaft.
- Secure fixed joint assembly in vise.

CAUTION:

Place copper or aluminum plates on side of assembly to prevent damage before tightening vise.

- Clean off old grease.
- Using brass shaft, rotate ball cage and remove steel balls from small holes in cage.

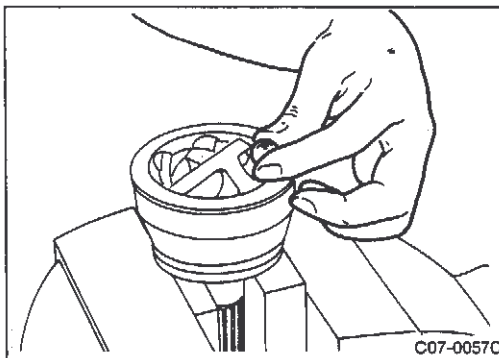

- After steel balls in four small holes have been removed, then remove steel balls from two large holes.

CAUTION:

The ball cage may break if steel balls are removed from large holes first.

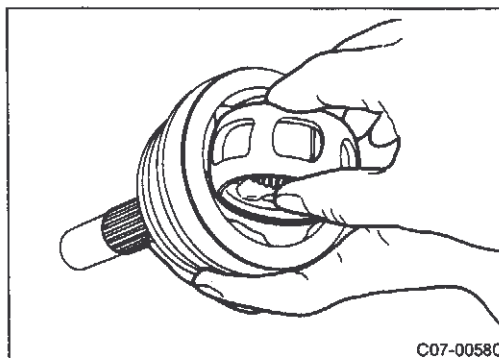

- Align outer race protrusion in large hole of ball cage. Remove ball cage and inner race from outer race at same time.

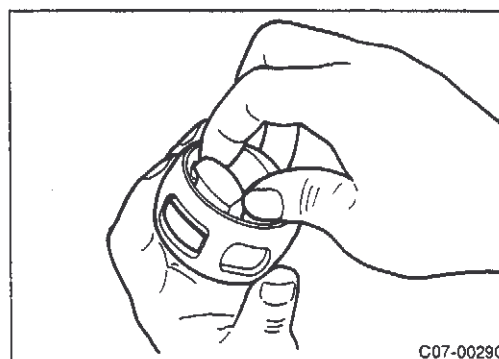

- Align inner race protrusion in large hole of ball cage and remove inner race from chamfered side of ball cage.

C6 DRIVE SHAFT

3. Drive shaft Removal and Installation, Assembly and Disassembly (Cont'd)

Disassembly inspection

- Clean parts and check following items.

Part	Description
Fixed joint assembly	<ul style="list-style-type: none"> ● Joint rotational condition, abnormal play in axial direction ● Foreign matter inside joint
Outer race	<ul style="list-style-type: none"> ● Damage or abnormal wear in ball contact surface ● Damage to drive shaft threads ● Boot installation deformation
Ball cage	<ul style="list-style-type: none"> ● Damage or abnormal wear in sliding surfaces
Steel balls	<ul style="list-style-type: none"> ● Damage or abnormal wear
Inner race	<ul style="list-style-type: none"> ● Damage or abnormal wear to ball contact surface ● Damage to serration holes (Check drive shaft serration holes at same time.)

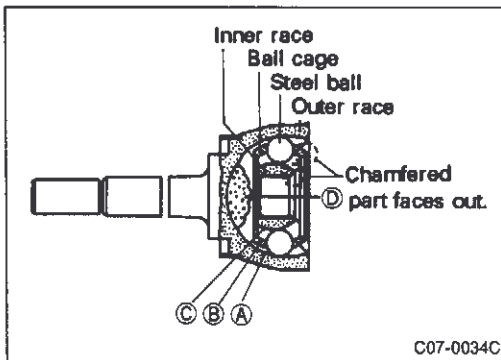

Assembly

- Coat outer race ball contact surface, ball cage sliding parts, inner race ball contact surface with repair kit grease.
- Install inner race in ball cage.

CAUTION:

Check that the installation direction of the inner race and ball cage (refer to figure) is correct.

- Install ball cage and inner race in outer race.
- Install steel balls in ball cage.

CAUTION:

Install steel balls in reverse sequence of disassembly. First install steel balls in the two large holes and then install remaining balls one at a time in the four small holes.

- Insert repair kit grease from inner race serration holes.

Part	Grease quantity g (oz)
Outer race ball contact surface (A)	Approx. 10 (0.35) each, total 30 (1.06)
Ball cage sliding parts (B)	
Inner race ball contact surface (C)	
Inner race serration holes (D)	30 (1.06)

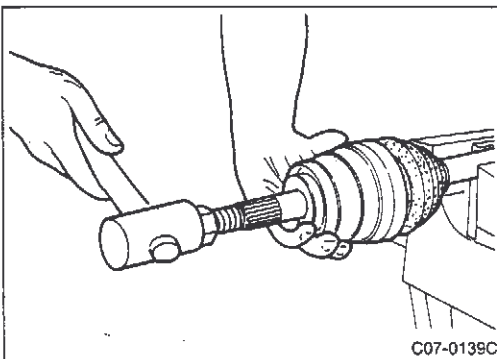

- Install boot with new boot band on drive shaft.
- Install snap ring and circlip on drive shaft.
- Install nut on fixed joint assembly and tap with wooden hammer to press-fit on drive shaft.

CAUTION:

Circlip must be inserted in shaft groove securely.

C6 DRIVE SHAFT

3. Drive shaft Removal and Installation, Assembly and Disassembly (Cont'd)

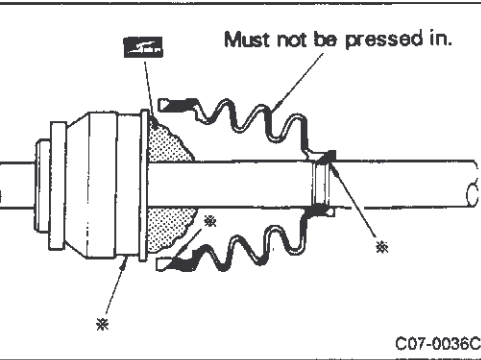

- Apply remaining repair kit grease to inside of housing from large opening of boot.

Model	Grease quantity g (oz)
Z80T70C	Approx. 120 (4.23)
Z80T82F	Approx. 120 (4.23)
B100D100	Approx. 180 (6.35)

CAUTION:

Remove grease from fixed joint boot installation surface (locations indicated by * in figure). The boot may come off if there is grease on the boot installation surface.

- Install boot securely in grooves (locations indicated in figure).
- Set boot length (L) as indicated below and secure with boot band.

CAUTION:

- (1) If boot installation length is shorter than dimension indicated below it may cause boot to break or split.
- (2) Be careful not to touch the inside surface of boot with end of screwdriver.

Model	Installation length mm (in)
Z80T70C	90.5 - 92.5 (3.563 - 3.642)
Z80T82F	90.5 - 92.5 (3.563 - 3.642)
B100D100	102 (4.02)

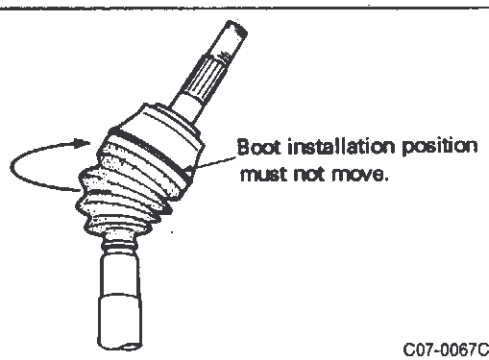



- Check boot installation. Rotate joint as shown in figure and check that boot installation position does not move. If position moves, install boot band one more time.

C7 FRONT SUSPENSION AND AXLE

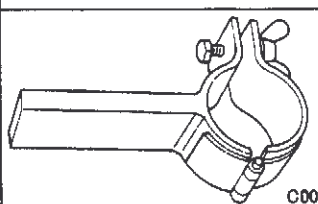

OPERATION PRECAUTIONS

- When installing each rubber bushing, final tightening must be carried out with vehicle on ground in unladen condition. Clean off all oil from rubber parts thoroughly because it may lower durability.
- Use flare wrench to remove brake piping. Use flare torque wrench (special service tool: GG9431 0000) to remove brake piping.
- Use flare nut wrench for removal and installation of steering piping flare nuts.
- Check wheel alignment when servicing suspension parts.

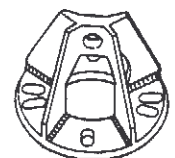
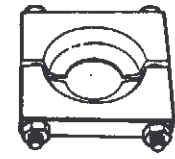
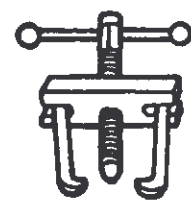
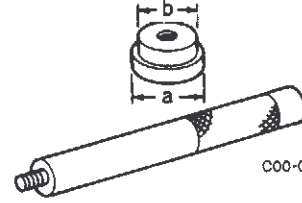

Required tools

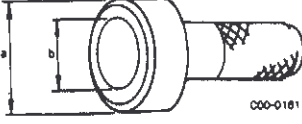
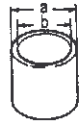
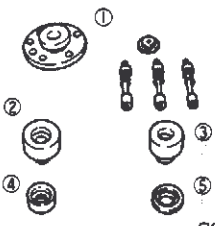
	Name	Description	Remark
	Brake tube torque wrench GG9431 0000  C00-0002	Tightening brake tube flare nuts	
	Strut attachment ST3565 2000  C00-0004	Removing coil springs	
	Slide hammer ST3623 0000  C00-0010	Removing hub outer bearings	
Special service tools	Attachment KV401 04100  C00-0104	Same as above	Already described
	Bearing replacer ST3003 1000  C00-0014	Same as above	
	Bearing puller ST3305 1001  C00-0203	Same as above	
	Drift ST3070 1000 Drift bar ST3532 5000 a: 61.5 mm (2.421 in) dia. b: 41 mm (1.61 in) dia.  C00-0152	Removing wheel (unit) bearing outer race	

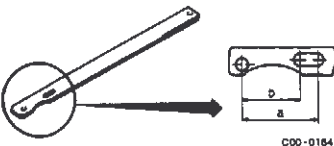
C7 FRONT SUSPENSION AND AXLE

	Name	Description	Remark	
	Drift KV401 5110 a: 48 mm (1.89 in) dia. b: 40 mm (1.57 in) dia.	 C00-0229	Wheel hub and outer bearing installation	
	Drift ST3340 0001 a: 60 mm (2.36 in) dia. b: 47 mm (1.85 in) dia.	 C00-0181	<ul style="list-style-type: none"> ● Installing knuckle spindle and wheel hub ● Removing and installing tension rod bushings 	
	Drift KV401 04710 a: 76.2 mm (3.000 in) dia. b: 68 mm (2.68 in) dia.	 C00-0195	Removing and installing tension rod bushings Installing wheel (unit) bearing outer race	
Special service tools	CCK gauge attachment KV991 040S0 ① KV991 04010 Plate assembly ② KV991 04020 Adapter A [outer diameter 72 mm (2.83 in)] ③ KV991 04030 Adapter B [outer diameter 65 mm (2.56 in)] ④ KV991 04040 Adapter C [outer diameter 57 mm (2.24 in)] ⑤ KV991 04050 Adapter D [outer diameter 53.4 mm (2.102 in)]	 C00-0230	Inspecting and measuring wheel alignment	Already described
	Drift KV401 05220 a: 75 mm (2.95 in) dia. b: 62 mm (2.44 in) dia.	 C00-0243	Installing wheel (unit) bearing outer race	
	Flange wrench KV101 09900 a: 100 mm (3.94 in) b: 54 mm (2.13 in)	 C00-0184	Tightening wheel bearing lock nut	

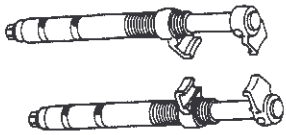
C7 FRONT SUSPENSION AND AXLE

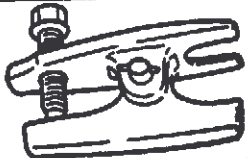
	Name	Description	Remark
Commer- cial ser- vice tools	Spring compressor HT7178 0000	 C00-0007	Removing and installing coil springs
	Pitman arm puller HT7256 0000	 C00-0231	Removing side rod and lower ball joint
	Ball joint remover HT7275 0000	 C00-0006	Removing suspension lower ball joint bolts
Measure- ment tools	Turning radius gauge (IM2355)		Measuring wheel alignment
	Alignment gauge (IM2360)		
	Toe-in gauge		
	Side slip tester		

C7 FRONT SUSPENSION AND AXLE

1. Summary

Specifications

Description		Engine	RB26DETT
Suspension type			Multi-link independent suspension
Wheel alignment (unladen vehicle)	Toe-in	mm (in)	1 ± 1 (0.04 ± 0.04)
	Camber	(°)	-0°55' ± 45'
	Caster	(°)	3°40' ± 45'
	King pin inclination angle	(°)	15°25' ± 45'
	Side slip (reference)	mm (in)	-5 to 5 (-0.20 to 0.20)
Shock absorber	Damping force [at 0.3 m (1.0 ft)/s] N (kg, lb)	Extension side	1,746 (178, 392)
		Compression side	500 (51, 112)
Coil spring	Spring constant	N/mm (kg/mm, lb/in)	23.5 (2.4, 134)
	Free length right/left	mm (in)	405 (15.94)
	Coil average diameter	mm (in)	110 (4.33) [low side 80 (3.15)]
	Line diameter	mm (in)	12.3 (0.484)
	Number of active coils		7.92
Tension rod diameter		mm (in)	20 (0.79)
Stabilizer outer diameter (non-solid)		mm (in)	20 (0.79)

Inspection specifications

Description		Standard Value	
Wheel alignment		Refer to "Specifications".	
Steering angle (°)	Inner wheel	38° ^{+1°} _{-3°}	
	Outer wheel	31°	
Wheel bearing lock nut tightening torque	N·m (kg-m, ft-lb)	235 - 314 (24 - 32, 174 - 231)	
Wheel bearing axial end play	mm (in)	0.05 (0.0020) max.	
Toe pre-adjustment side rod length	mm (in)	126.5 (4.98)	
Lower link ball joint and suspension lower ball joint	Description	Lower link ball joint	Suspension lower ball joint
	Swing torque (spring balance conversion value) N (kg, lb)	8.8 - 63.7 (0.9 - 6.5, 2.0 - 14.3)	6.9 - 50.0 (0.7 - 5.1, 1.5 - 11.2)
	Sliding torque N·m (kg-m, ft-lb)	0.5 - 3.4 (0.05 - 0.35, 0.4 - 2.5)	
	Axial end play mm (in)	0 (0)	
	Tightening torque N·m (kg-m, ft-lb)	96 - 120 (9.8 - 12.2, 71 - 88)	

C7 FRONT SUSPENSION AND AXLE

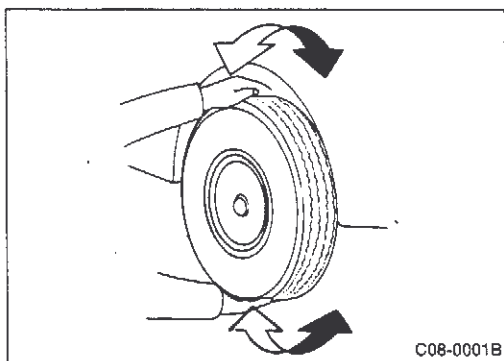

2. On-vehicle Inspection and Preparation

2-1 FRONT SUSPENSION AND AXLE INSPECTION

- Shake left and right front tires. Check tires, wheel bearing and king pin bearings for looseness. Rotate tire by hand and check for abnormal noise.
- Replace if there is looseness or damage.

CAUTION:

There may be a small amount of play in the upper link but this is not abnormal.

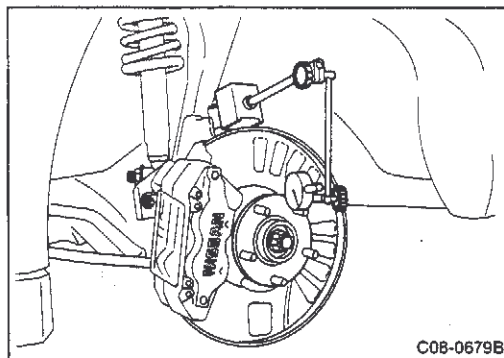

- If there is axial play in locations other than upper link, check axle end play.

End play standard value:

0.05 mm (0.0020 in) max.

- The normal preload adjustment is not necessary because a unit bearing is used.
- If problem is found in inspection, disassemble and analyze problem to determine cause.

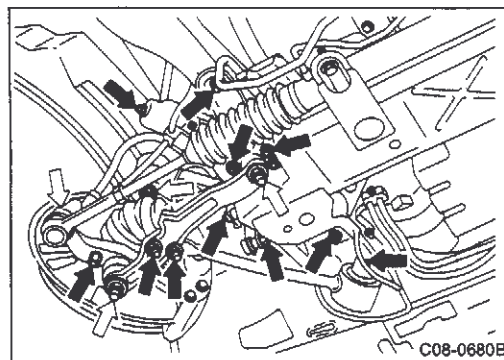

- Check suspension parts (↔) for looseness and make sure cotter pins (↔) are inserted.

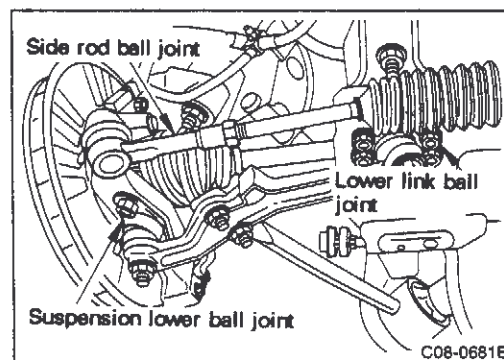

- Check ball joints for grease leaks and dust cover for damage.

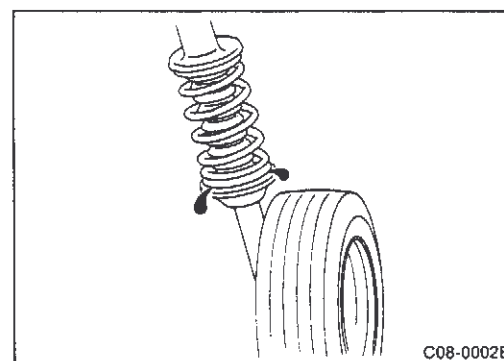

2-2 SHOCK ABSORBER OIL LEAK INSPECTION

- Check shock absorber for oil leakage.
- Check for fatigue, damage or deformation.
- The front shock absorber cannot be disassembled. Replace entire shock absorber assembly if necessary.

C7 FRONT SUSPENSION AND AXLE

2. On-vehicle Inspection and Preparation (Cont'd)

2-3 WHEEL ALIGNMENT INSPECTION AND ADJUSTMENT

Operation inspection

- Is tire wear and inflation pressure normal? (Refer to C9 WHEELS AND TIRES.)
 - Is wheel bearing axial end play normal?
 - Is there deformation in load wheel?
 - Is there looseness in suspension ball joint and lower link ball joint?
 - Is shock absorber operation normal?
 - Are axle and suspension parts loose or damaged?
 - Is vehicle posture normal?
 - Is there damage, cracks or deformation in suspension link?
 - Is vehicle unladen*?
- * Fuel, radiator coolant and engine oil full. Spare tire, jack, hand tools and mats in designated positions.

Operation procedures

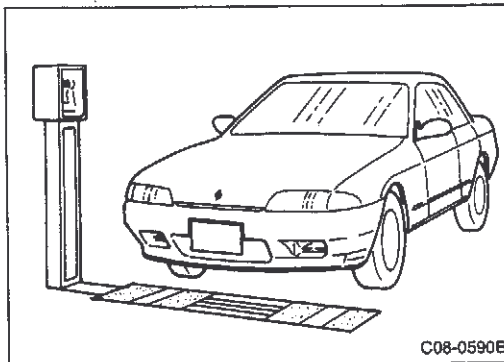
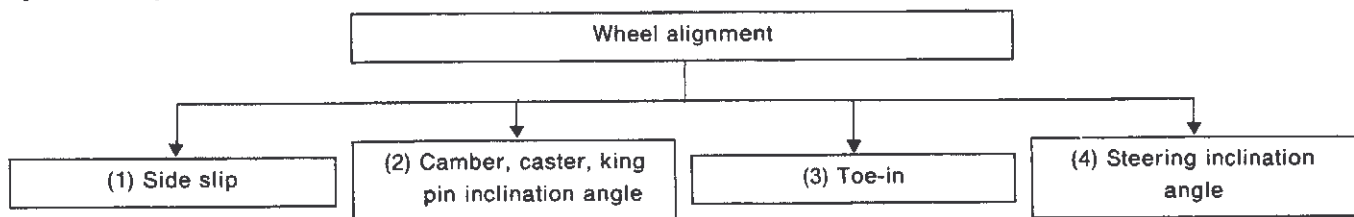

(1) Side slip distance inspection

- Check side slip distance. If it is within standard specification, wheel alignment can be considered to be normal.

CAUTION:

This can only be considered only when operational vertical stability is incorrect and there are no abnormalities in pre-operational inspection.

Front side slip distance standard value:
-5 to 5 mm (-0.20 to 0.20 in)

C7 FRONT SUSPENSION AND AXLE

2. On-vehicle Inspection and Preparation (Cont'd)

(2) Camber, caster, king pin angle inspection and measurement

If vehicles equipped with aluminum road wheels or if the alignment gauge installation surface (hub end) is more concave than road wheels, then use the CCK gauge attachment (special service tool: KV991 040S0) to perform the operations described below.

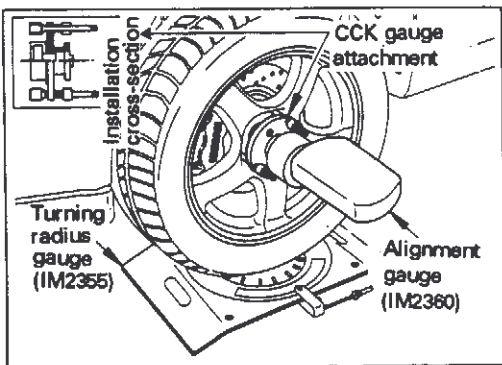
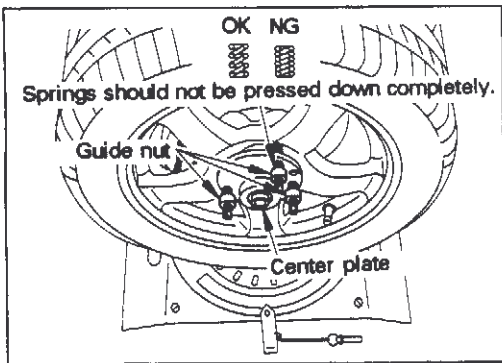
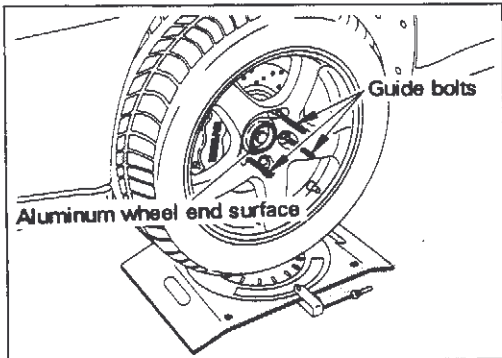

Set turning radius gauge on front wheels with vehicle on level ground.

Set rear wheels on stand that is same height as turning radius gauge.

Remove the wheel nuts and center caps. Screw the guide bolts on hub bolts as shown in figure.

Install adapter B on attachment.

Note 1: Screw nuts until adapter is mounted securely on attachment.

Tighten guide nuts uniformly until adapter is seated securely on aluminum wheel end surface.

Note 2: Do not tighten nuts until springs are pressed completely down.

Set alignment gauge on CCK gauge attachment and perform measurement.

Description	Specification
Camber	$-0^{\circ}55' \pm 45'$
Caster	RB26DETT: $3^{\circ}40' \pm 45'$
King pin angle	$15^{\circ}25' \pm 45'$

Measure toe-in.

C7 FRONT SUSPENSION AND AXLE

2. On-vehicle Inspection and Preparation (Cont'd)

(3) Toe-in inspection and adjustment

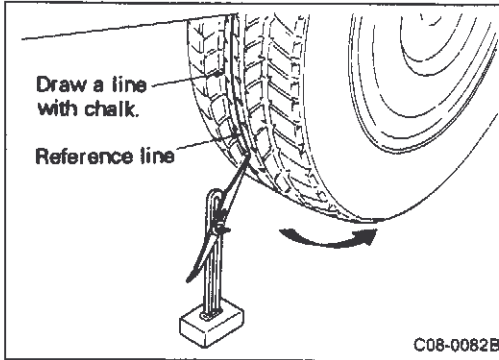

Jack up front of vehicle and set on stands. Draw a base line on tread surface of tires with chalk.

After lowering front of vehicle, move it up and down to eliminate friction.

Set steering wheel in straight-ahead position.

Adjust toe-in gauge to wheel center height and measure distance from standard line.

Measure dimensions A and B at same height as hub center as shown in figure and calculate toe-in.

Toe-in = $A - B$ mm (in)

Toe-in standard value: 1 ± 1 mm
(0.04 ± 0.04 in)

When toe-in is out of specification

Loosen lock nut as shown in figure. Adjust toe-in by varying the length of steering tie-rods.

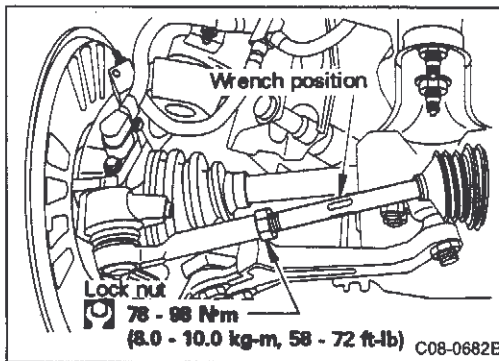
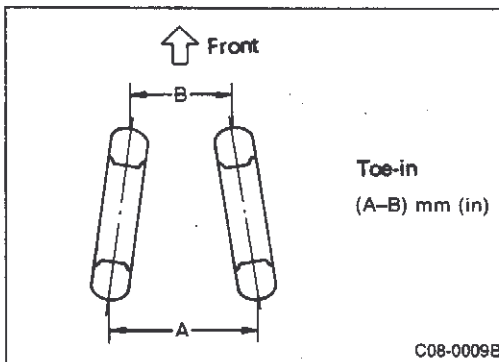
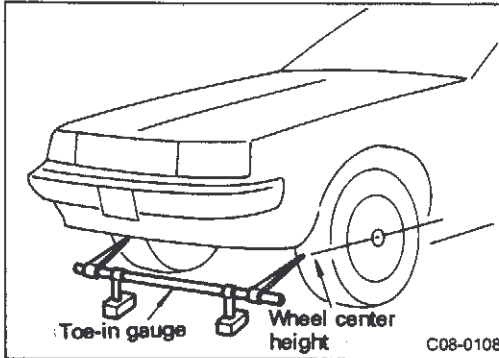

CAUTION:

- (1) When adjusting steering tie-rods, turn the tie-rods the same distance forwards or backwards.
- (2) When replacing tie-rods, set the length to the specification indicated below and adjust toe-in.
- (3) When tightening lock nuts, secure tie rod with another wrench.
- (4) After adjustment, the tie-rod outer ball socket must face straight ahead.

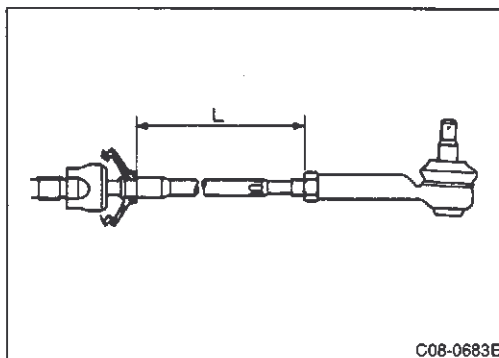

Tie-rod standard length "L" dimension: 126.5 mm (4.98 in)

C7 FRONT SUSPENSION AND AXLE

2. On-vehicle Inspection and Preparation (Cont'd)

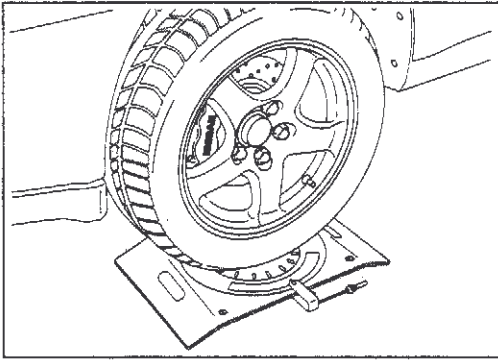

(4) Front wheel turning angle

- Set wheels in straight-ahead position and then move vehicle forward until front wheels rest on turning radius gauge properly. Rotate steering wheels all the way right and left and measure turning angle.

Standard value	Inner wheel	$38^{\circ} + 1^{\circ}$
	Outer wheel	32°

CAUTION:

Turning angle is set by the stroke length of steering gear, and cannot be adjusted.

(5) Trouble diagnosis

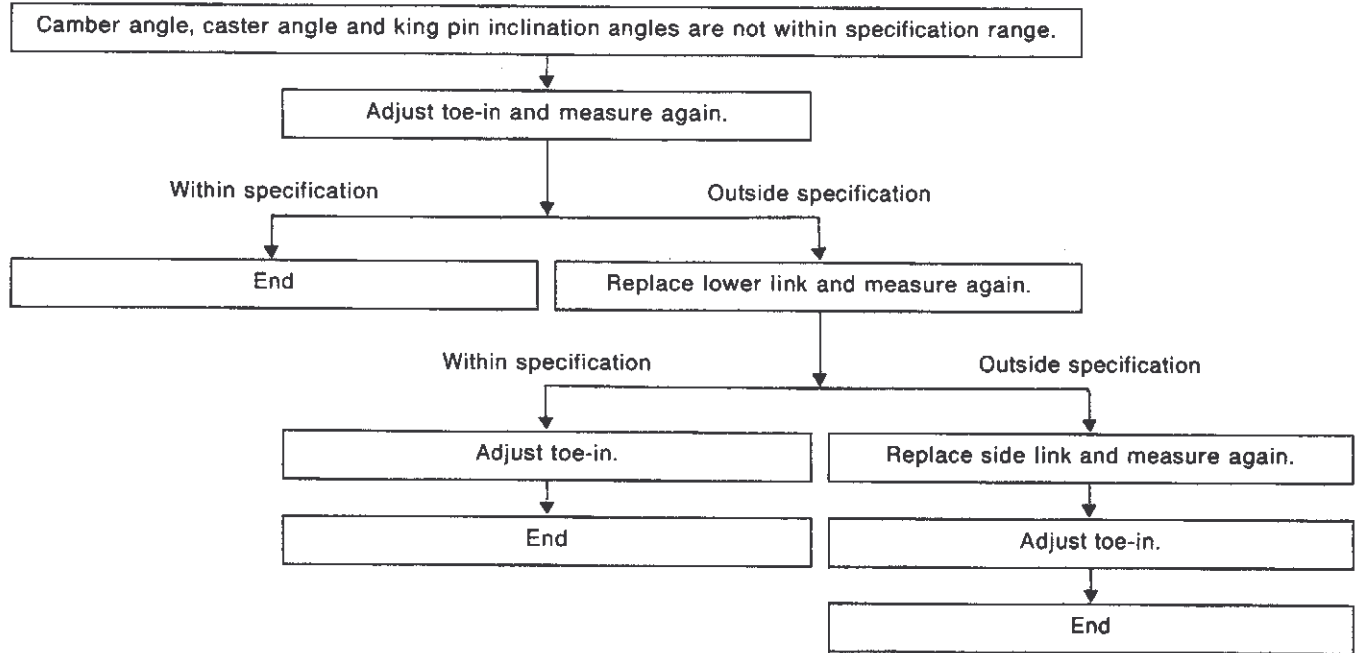

Item	Specification
Camber	$-0^{\circ}55' \pm 45'$
Caster	RB26DETT: $3^{\circ}40' \pm 45'$
King pin angle	$15^{\circ}25' \pm 45'$

C7 FRONT SUSPENSION AND AXLE

3. Part Removal and Installation, Assembly and Disassembly

3-1 FRONT SUSPENSION

(1) Removal and installation from vehicle

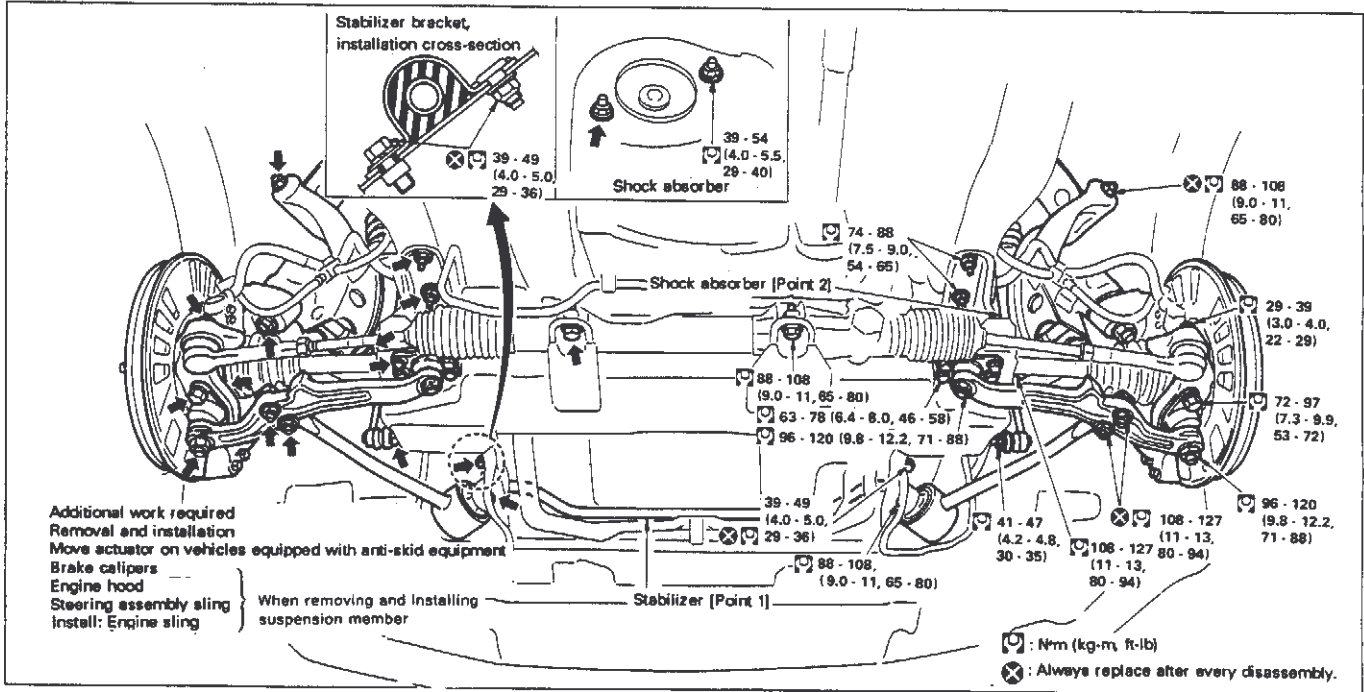

CAUTION:

- (1) When tightening links, first tighten temporarily and then tighten again under unladen condition*.
* Fuel, radiator coolant and engine oil full. Spare tire, jack, hand tools and mats in designated positions.
- (2) Do not press brake pedal while brake caliper assembly is removed.

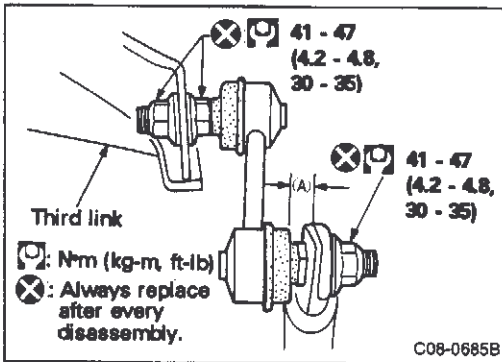

[Point 1] Stabilizer installation

- The stabilizer uses a pillow-ball type connecting rod system. Observe following precautions when setting ball joint position during assembly.

CAUTION:

The distance "A" must be set so pillow-ball and connecting rod are perpendicular to stabilizer bar as shown in figure.

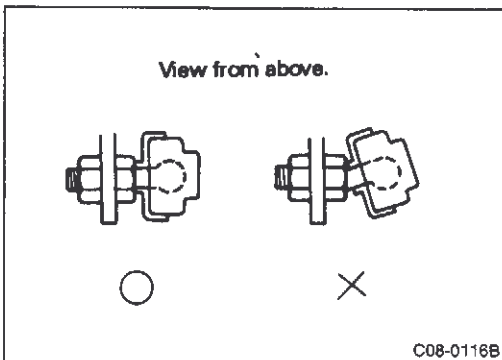

- Apply torque to inner nut on third link side and then tighten.
- Insert seating nut in lock hole on stabilizer side and tighten.

C7 FRONT SUSPENSION AND AXLE

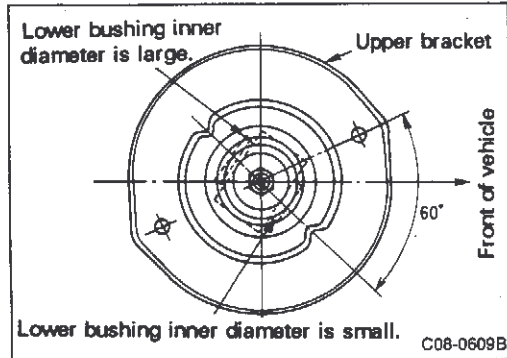
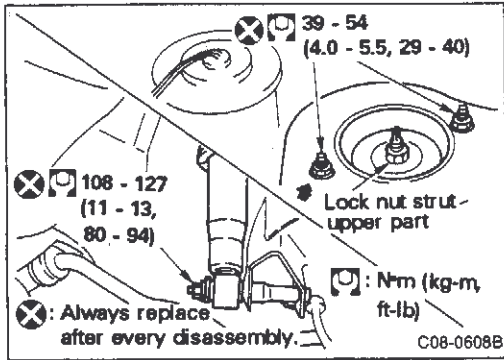

3. Part Removal and Installation, Assembly and Disassembly (Cont'd)

[Point 2] Shock absorber assembly removal and installation

Removal

- Remove shock absorber fixing nuts from body when shock is extended.

CAUTION:

Do not remove piston rod lock nut.

- Remove nuts from lower part of shock absorber (installed in third link).

Installation

- Position small diameter side of shock absorber lower bushing so it faces front of vehicle. Assembly is reverse of disassembly sequence.
(The figure is cross-section of left shock absorber viewed from above.)

C7 FRONT SUSPENSION AND AXLE

3. Part Removal and Installation, Assembly and Disassembly (Cont'd)

(2) Assembly and disassembly

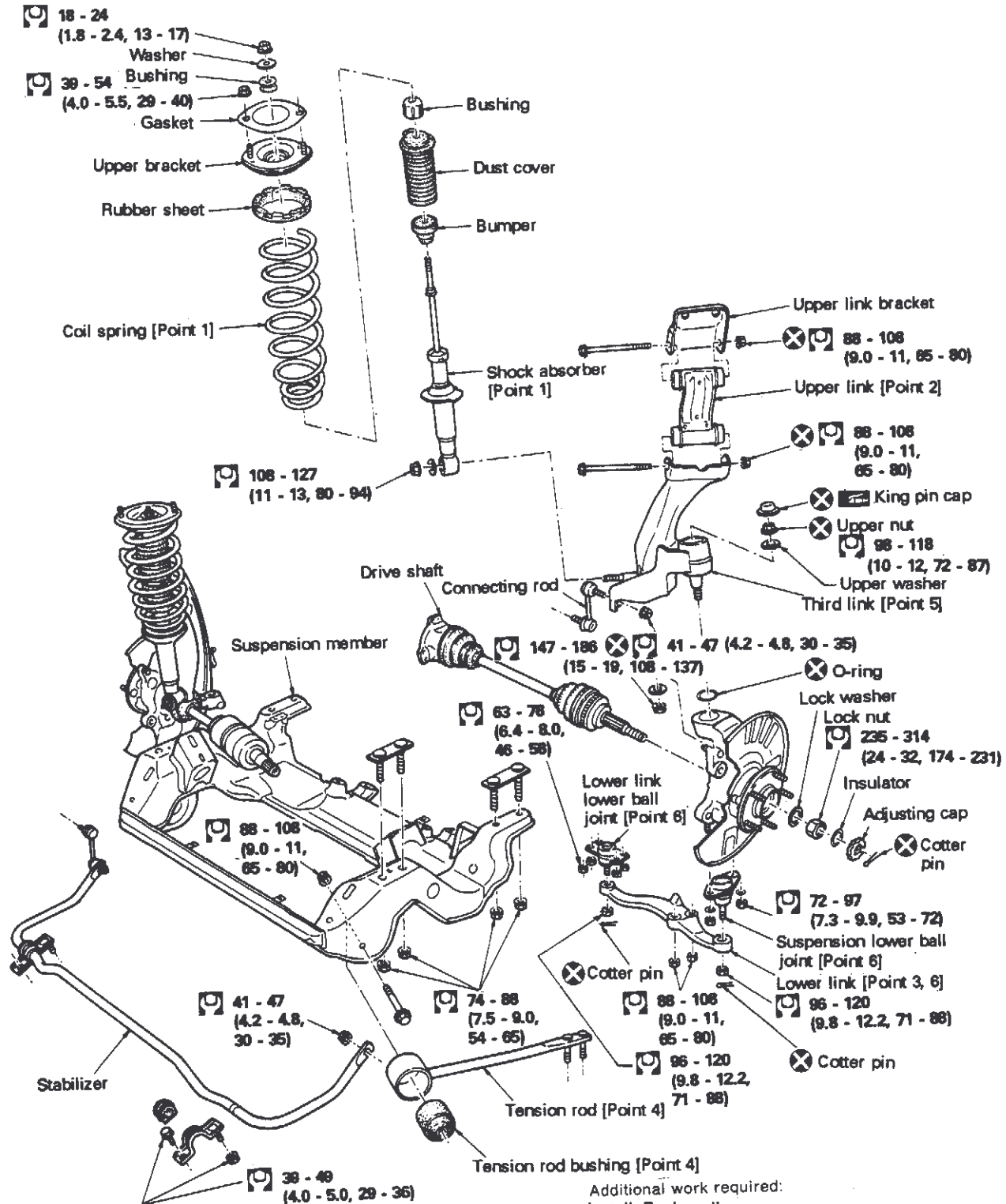

- After installing each suspension part, check and adjust wheel alignment.
- All bushings and washers have a specified direction. Pay attention to direction during installation.
- Be careful not to get grease and oil on bushing.
- When tightening tension rods, the vehicle must be in unladen condition with wheels on ground for final tightening.
- The knuckle spindle is made of aluminum and electrical corrosion will occur where it contacts other metallic objects. Apply bitumen wax after assembly and disassembly.

Additional work required:

- Install: Engine sling
- Remove and install: Engine mount nuts
- Engine hood
- Separate brake hoses and tube
- Inspect all parts [Point 6]

☐ : N•m (kg-m, ft-lb)

⊗ : Always replace after every disassembly.

☒ : Apply Nissan MP special grease No. 2.

C08-0686B

C7 FRONT SUSPENSION AND AXLE

3. Part Removal and Installation, Assembly and Disassembly (Cont'd)

[Point 1] Coil spring removal and installation

Removal

- Before removal, inscribe mating marks on shock absorber and coil spring as shown in figure.

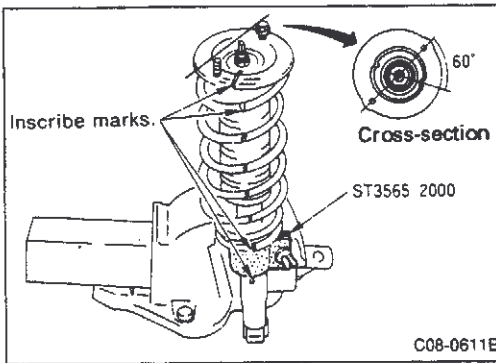

- Secure attachment (special service tool) to shock absorber assembly and place in vise.
- Use a spring compressor (commercial service tool) and compress coil spring.
- Do not damage piston rod. Remove piston rod lock nut as shown in figure.

CAUTION:

Compress coil spring. Check that coil spring is free between upper sheet and lower sheet and remove piston rod lock nut.

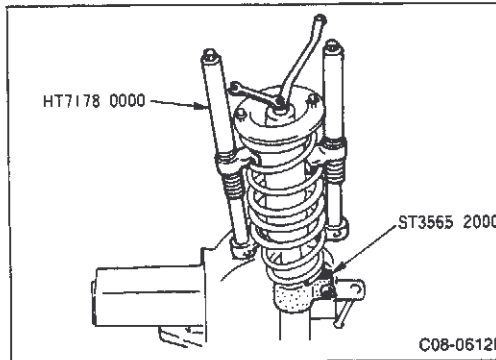

Installation

- Pay attention to vertical direction and assemble spring.

CAUTION:

Make sure the small diameter spring end faces down and large diameter end is on top.

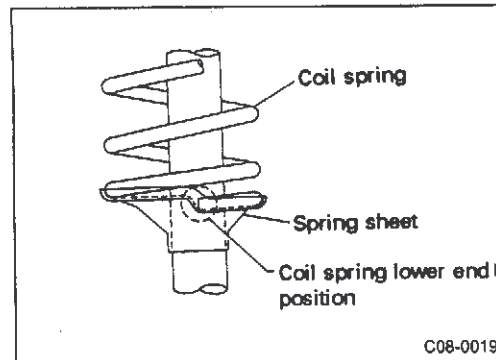

- Check that spring is seated securely in spring seat. Position spring so upper side (body side) and lower side (third link side) are at 60° angle as shown in figure.

CAUTION:

If the angle is not correct the shock absorber cannot be installed in vehicle.

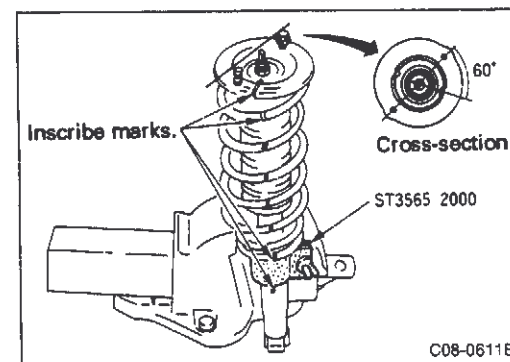

[Point 2] Upper link installation

- Check that directional marks are positioned correctly for upper link installation. Always install upper link with 'A' side facing axle and unmarked side facing body.

CAUTION:

Upper link bushing cannot be disassembled.

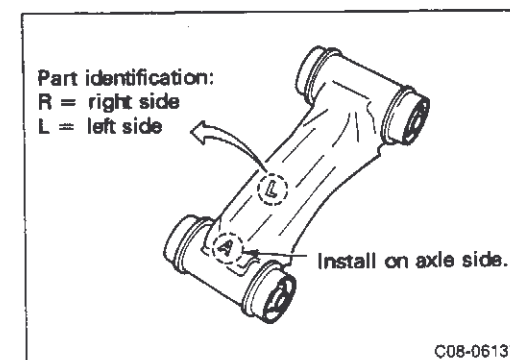

C7 FRONT SUSPENSION AND AXLE

3. Part Removal and Installation, Assembly and Disassembly (Cont'd)

[Point 3] Lower link and tension rod removal and installation and assembly sequence

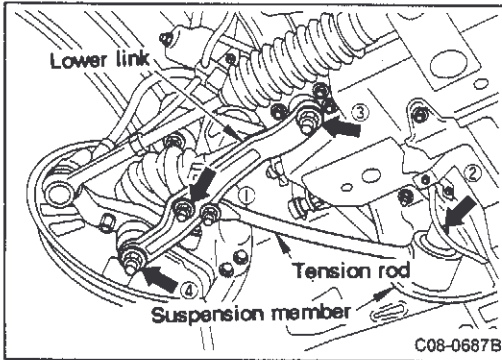

Removal

- Loosen nuts at positions indicated by arrow marks in figure.

Installation

- When suspension is not compressed (rebound):
 - Temporarily tighten lower link and tension rod.
 - Temporarily tighten tension rod bushing and front suspension member connection.
 - Temporarily tighten lower link and suspension member lower ball joint connection.
 - Temporarily tighten lower link and suspension lower ball joint connection.
- When vehicle is unladen, tighten nuts to specified torque in sequence ②, ③, ①, ④.

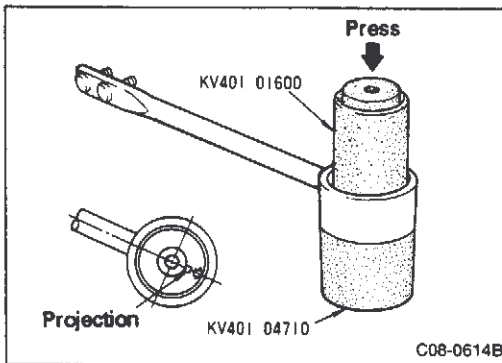

[Point 4] Tension rod bushing replacement

- To replace tension rod bushing, place drift [inner diameter 66 mm (2.60 in), outer diameter 75 mm (2.95 in)] below rod and drift [inner diameter 25 to 55 mm (0.98 to 2.17 in), outer diameter 62 mm (2.44 in)] on top and remove or install in press.
- Align bushing arrow mark in opposite direction from rod and then assemble.
Reference: Use the following special service tools.
Upper drift: KV401 01600
Lower drift: KV401 04710

[Point 5] Third link inspection and removal and installation

Inspection

- The kingpin bearing installed in third link usually does not require maintenance. Do not disassemble bearing unless there is a problem.

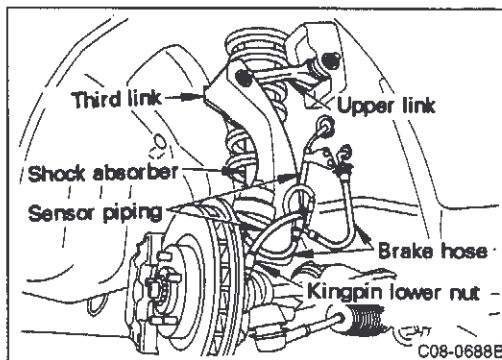

Removal

- Remove shock absorber.
- Remove brake hoses. Remove speed sensor piping in vehicles equipped with anti-skid system.
- Loosen kingpin lower nut.
- Loosen third link and upper link connections and remove.

C7 FRONT SUSPENSION AND AXLE

3. Part Removal and Installation, Assembly and Disassembly (Cont'd)

Installation

- Insert third link and kingpin assembly in knuckle spindle and tighten lower nuts to specified torque.
- Connect third link and upper link.
- Install brake hoses. Install speed sensor piping in vehicles equipped with anti-skid system.
- Install shock absorber.

King pin lower nut tightening torque:

147 - 186 N·m (15 - 19 kg-m, 108 - 137 ft-lb)

[Point 6] Inspection

- ① Coil spring
 - Replace if cracked or deformed.
- ② Front suspension member
 - Replace if cracked or deformed.
- ③ Third link
 - If third link is cracked or deformed, replace kingpin bearing assembly.
- ④ Lower link
 - Replace if cracked or deformed.
- ⑤ Suspension lower and lower link ball joints
 - Use Pitman arm puller (commercial service tool) to separate suspension lower ball joint and lower the lower link ball joint from lower link as shown in figure.

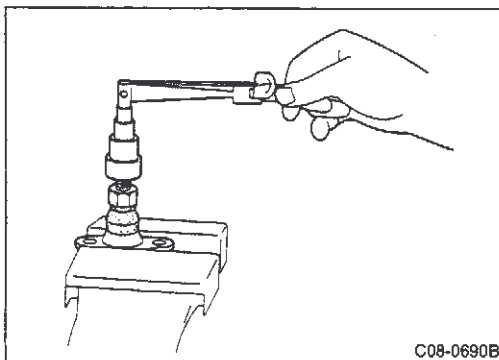
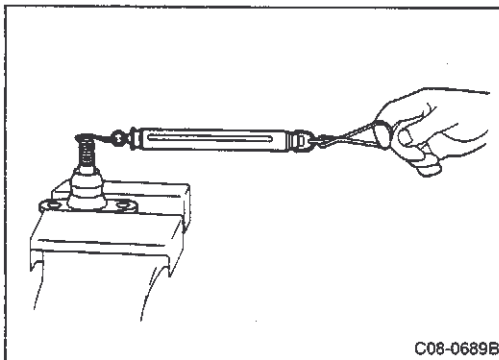
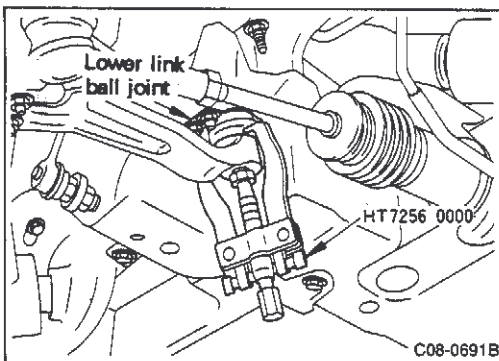

Swing torque inspection

Specification (spring balance reading): N (kg, lb)

Suspension lower ball joint

6.9 - 50.0 (0.7 - 5.1, 1.5 - 11.2)

Lower link lower ball joint

8.8 - 63.7 (0.9 - 6.5, 2.0 - 14.3)

CAUTION:

Swing more than 10 times by hand before measurement.

Measure the spring balance at height of ball stud cotter pin ball.

Sliding torque inspection

Specification: N·m (kg-m, ft-lb)

Suspension lower ball joint

0.5 - 3.4 (0.05 - 0.35, 0.4 - 2.5)

Lower link lower ball joint

0.5 - 3.4 (0.05 - 0.35, 0.4 - 2.5)

CAUTION:

Swing more than 10 times by hand before measurement.

C7 FRONT SUSPENSION AND AXLE

3. Part Removal and Installation, Assembly and Disassembly (Cont'd)

Axial end play inspection

Specification: mm (in)

Suspension lower ball joint 0 (0)

Lower link lower ball joint 0 (0)

- If measurement value is outside standard specification range, replace ball joints.

C7 FRONT SUSPENSION AND AXLE

3. Part Removal and Installation, Assembly and Disassembly (Cont'd)

3-2 FRONT AXLE

(1) Removal and installation, assembly and disassembly

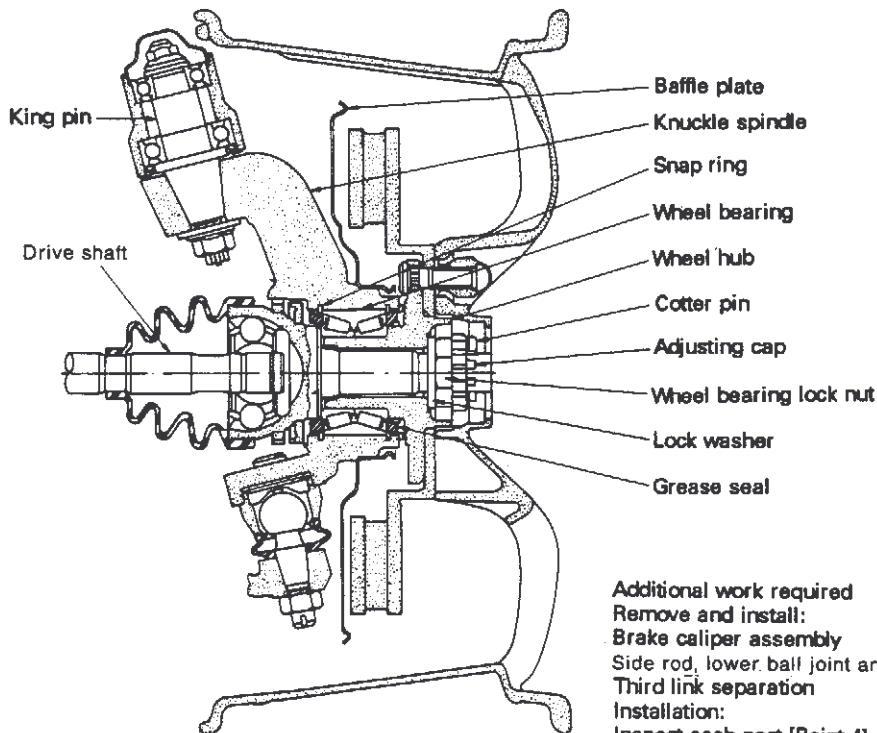
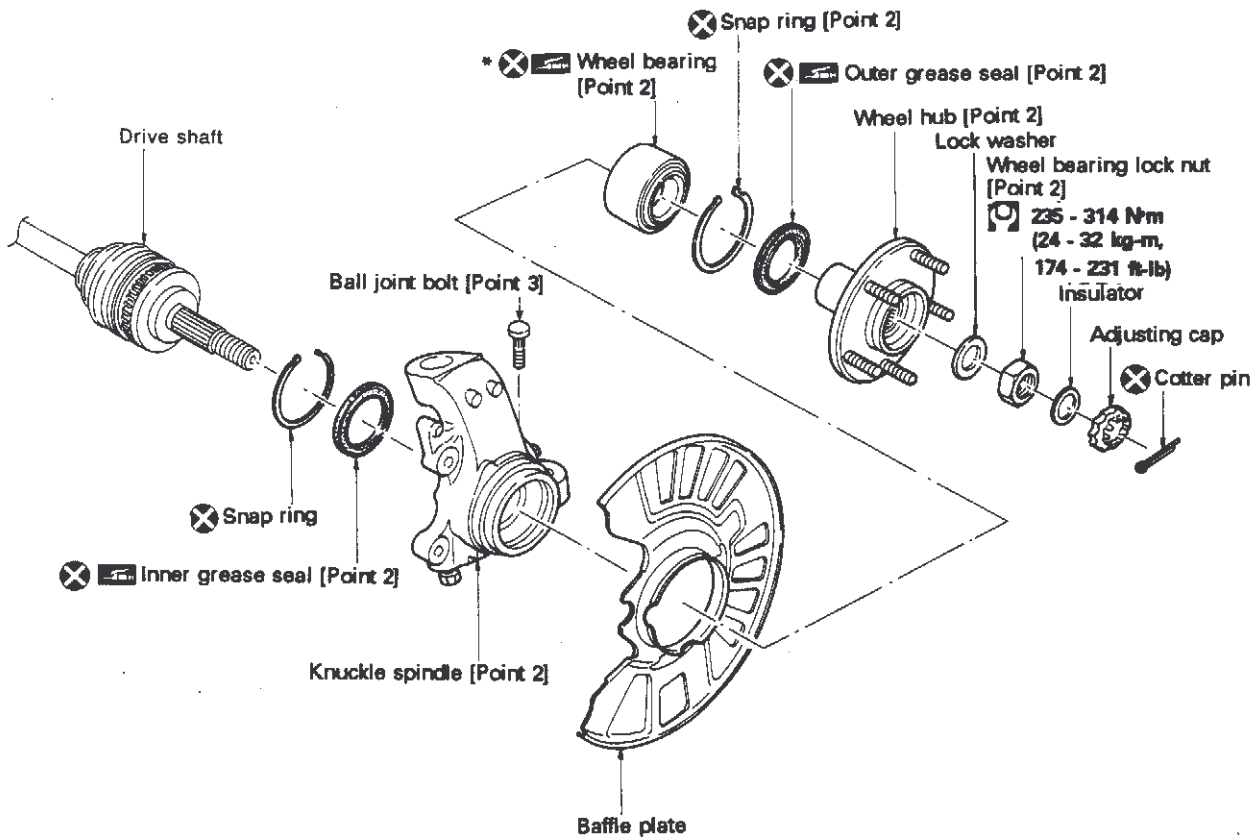

Additional work required

Remove and install:

Brake caliper assembly

Side rod, lower ball joint and lower link separation [Point 1]

Third link separation

Installation:

Inspect each part [Point 4]

⊗ : Always replace after every disassembly.

☒ : Apply Nissan MP special grease No. 2.

*: Replace as set.

C7 FRONT SUSPENSION AND AXLE

3. Part Removal and Installation, Assembly and Disassembly (Cont'd)

[Point 1] Separation of side rod, lower ball joint and lower link

- Place Pitman arm puller (commercial service tool) as shown in figure and separate side rod and suspension lower ball joint.

CAUTION:

The knuckle spindle is made of aluminum and scratches easily. Pay attention not to tap when using Pitman arm puller for removal.

- Use Pitman arm puller (commercial service tool) to separate suspension lower ball joint and lower link.

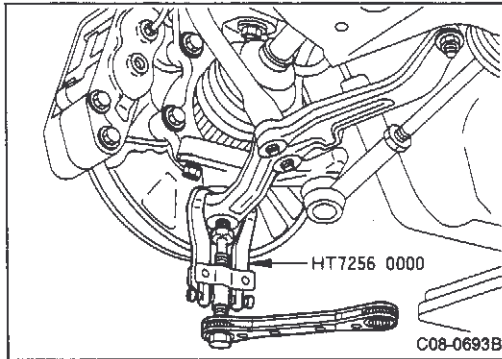
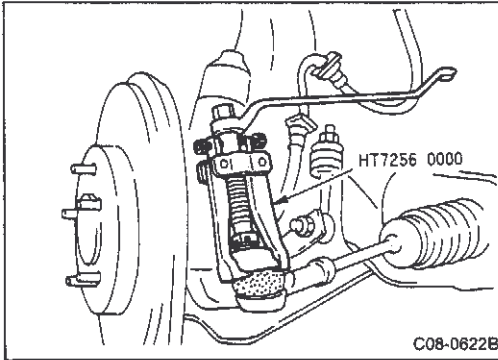

[Point 2] Wheel bearing removal and installation

- The wheel bearing usually does not require measurement. If any of the following problems are noted, replace wheel bearing assembly (including grease seal and snap ring).
 - ① Wheel bearing makes growling noise during vehicle operation.
 - ② When bearing lock nut is tightened to specified torque, wheel bearing drags or turns roughly when hub is turned by hand.
 - ③ When bearing is removed from hub.

Removal

- Protect knuckle hub with copper plates and rags and secure it in vise.
- Place attachment (special service tool) on knuckle hub bolts. Use sliding hammer (special service tool) to separate knuckle spindle.

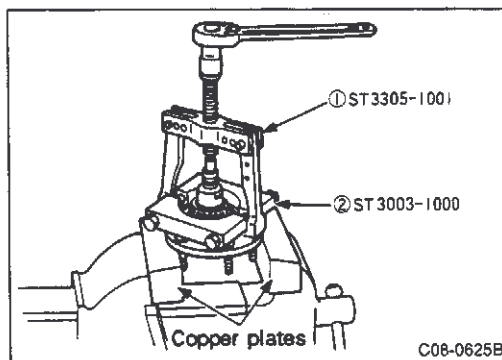
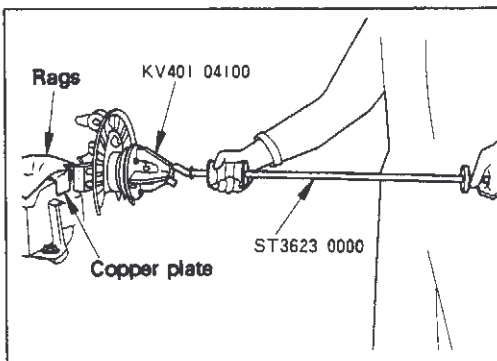

- ① Place bearing puller (special service tool), ② bearing replacer (special service tool) as shown in figure. Tighten on wheel hub and remove outer bearing.

C7 FRONT SUSPENSION AND AXLE

3. Part Removal and Installation, Assembly and Disassembly (Cont'd)

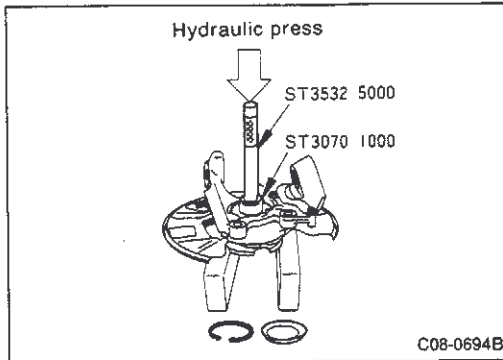

- Remove inner grease seal with screwdriver.

CAUTION:

Do not scratch knuckle spindle.

- Remove snap ring with snap ring pliers.
- Place drift (special service tool 61.5 mm dia.) against drift bar (special service tool) as shown in figure. Press out inner bearing and remove bearing outer race.

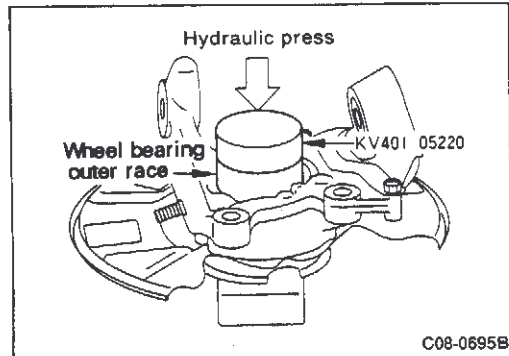

Installation

- Install new snap ring securely in groove on outside of knuckle spindle.
- Place wheel bearing outer race horizontally on knuckle spindle and press-fit with drift (special service tool). Stop insertion when bearing contacts snap ring on outer side.
- Install new snap ring securely in groove on inside of knuckle spindle. Install inner and outer bearings and inner and outer grease seals inside wheel.

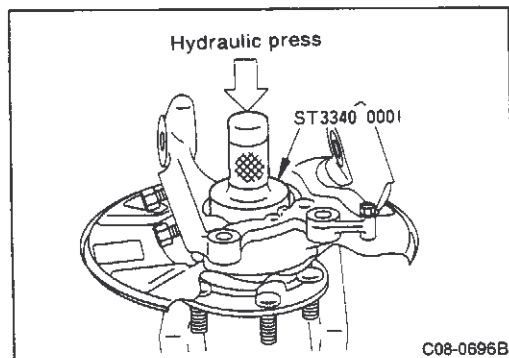
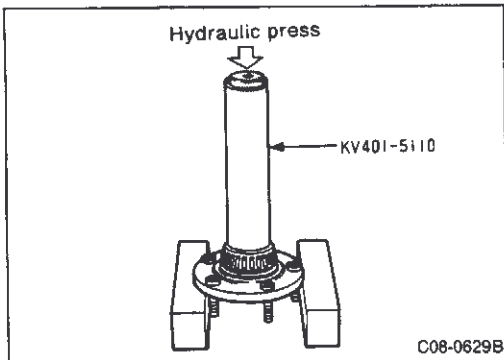

- Place wheel hub horizontally on block.
- Place drift [special service tool: inner diameter 46 mm (1.81 in), outer diameter 60 mm (2.36 in)] on knuckle spindle as shown in figure and press-fit assembly.

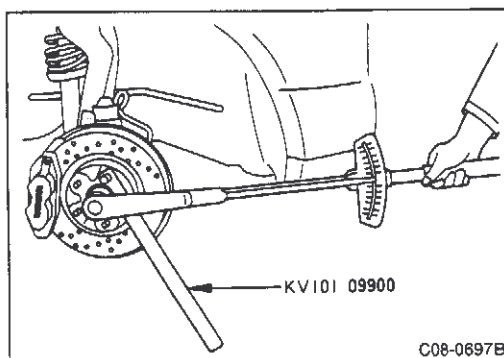

- Assemble drive shaft and install in vehicle.
- Tighten lock nuts to specified torque.
Lock nut standard torque:
235 - 314 N·m (24 - 32 kg·m, 174 - 231 ft·lb)
- Insert cotter pins and bend to secure.

C7 FRONT SUSPENSION AND AXLE

3. Part Removal and Installation, Assembly and Disassembly (Cont'd)

[Point 3] Suspension lower ball joint bolt removal and installation

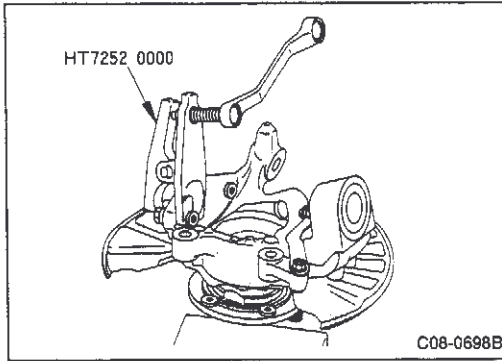

Removal

- The length below bolt head is serrated just like hub bolts. Use ball joint remover (commercial service tool) and remove bolts.

CAUTION:

Do not scratch knuckle spindle when pounding out bolts with hammer.

Installation

- Align serration of bolt below head with knuckle spindle serration hole and tap in with brass shaft.

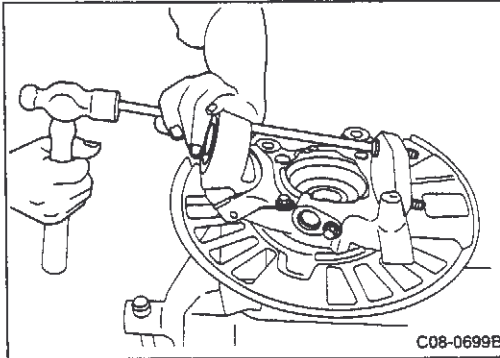

[Point 4] Inspection

- Inspect all parts and replace if the following problems are noted.
 - ① Wheel bearing is damaged, seized, rusted or does not turn easily.
 - ② Front hub is cracked. (Check with dyeing test damage detection method.)
 - ③ Knuckle spindle is deformed, dented, cracked (check with dyeing test damage detection method) or threads are damaged.

C8 REAR SUSPENSION AND AXLE

Tools required

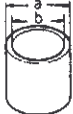
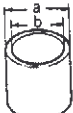
	Name	Application	Remark
Special service tool	Drift KV401 04710 a: 76.2 mm (3.000 in) dia. b: 68 mm (2.68 in) dia.	 C00-0195	Axle housing dust seal removal and installation
	Drift ST2786 1000 a: 62 mm (2.44 in) dia. b: 52 mm (2.05 in) dia.	 C00-0195	Axle housing bushing (shock absorber) removal and installation

1. Summary

Specifications

Description		Engine	RB26DETT
Suspension type			Multi-link independent suspension
Wheel alignment (unladen vehicle)	Toe-in	mm (in)	2 ± 2 (0.08 ± 0.08)
	Camber	mm (in)	-1°05' ± 30'
	Side slip distance (reference)	mm (in)	-5 to 5 (-0.20 to 0.20)
Shock absorber	Damping force [at 0.3 m (1.0 ft)/s]	Expansion side	1,108 (113, 249)
		Compression side	402 (41, 90)
Coil spring	Spring constant	N/mm (kg/mm, lb/in)	26.5 (2.7, 151)
	Free length	mm (in)	345 (13.58)
	Coil center diameter	mm (in)	100 (3.94) [lower side 90 (3.54)]
	Wire diameter	mm (in)	11.8 (0.465)
	Number of active coils		7.29
Stabilizer outer diameter (non-solid)		mm (in)	25.4 (1.000)

Inspection specifications

Item	Specification	
Wheel alignment	Refer to "Specifications".	
Wheel bearing lock nut tightening torque	N·m (kg-m, ft-lb) 206 - 275 (21 - 28, 152 - 203)	
Wheel bearing axial end play	mm (in) 0 (0)	
Suspension ball joint	Swing torque (spring balance conversion) N (kg, lb)	7.8 - 54.9 (0.8 - 5.6, 1.8 - 12.3)
	Sliding torque	N·m (kg-m, ft-lb) 0.5 - 3.4 (0.05 - 0.35, 0.4 - 2.5)
	Axial end play	mm (in) 0 (0)
	Tightening torque	N·m (kg-m, ft-lb) 78 - 93 (8.0 - 9.5, 58 - 69)

C8 REAR SUSPENSION AND AXLE

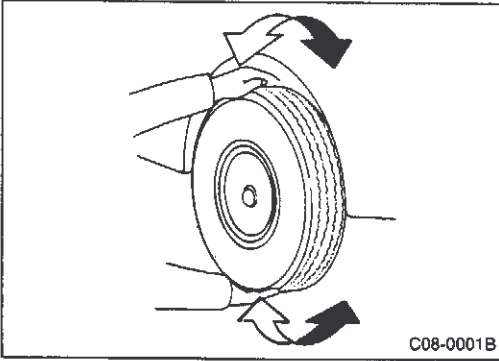

2. On-vehicle Inspection and Preparation

2-1 REAR SUSPENSION AND AXLE INSPECTION AND ADJUSTMENT

Inspection

- Check axle and suspension parts for looseness, wear or damage. Shake each rear wheel and check for noise and excessive play.

Adjustment

- If loose, retighten to specified torque.
- Replace all damaged parts.

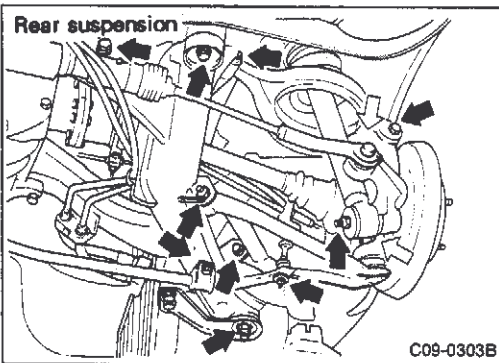

- Tighten rear suspension parts (↔) and check if cotter pins (↔) are inserted.

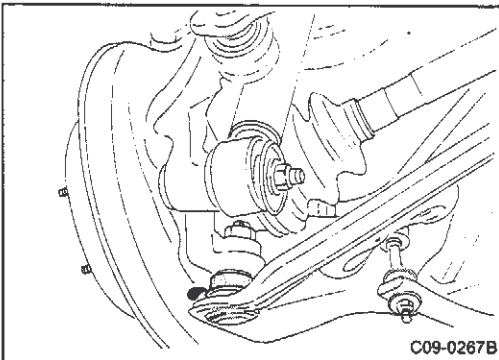

- Check ball joints for grease leakage and dust cover for cracks or other damage.

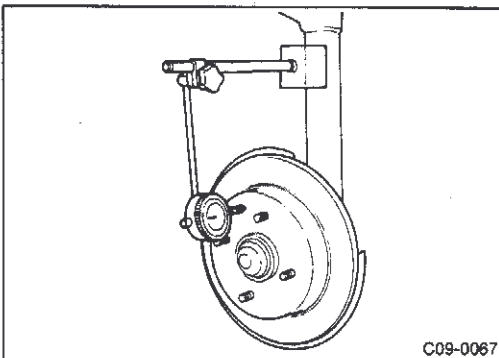

2-2 WHEEL BEARING INSPECTION

- If there is any axial end play, tighten wheel nuts to specified torque and check axle end play again.
End play standard value: 0 mm (0 in)
- A unit bearing is used so no preload adjustment is normally required.
- If any problem is noted, check axle.

C8 REAR SUSPENSION AND AXLE

2. On-vehicle Inspection and Preparation (Cont'd)

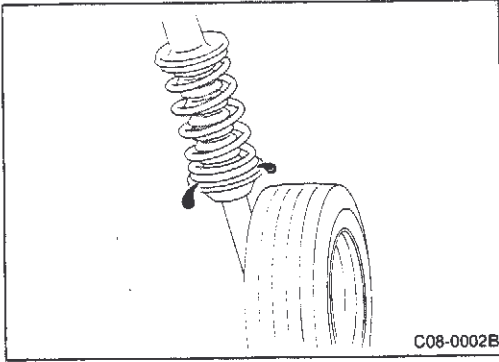

2-3 SHOCK ABSORBER INSPECTION

- Check shock absorber for grease leakage.
- Check for fatigue, cracks, deformation or other damage.
- The shock absorber cannot be disassembled. Replace entire unit if necessary.

2-4 WHEEL ALIGNMENT INSPECTION AND ADJUSTMENT

Inspection before operation

- Check tires for wear or improper inflation. Refer to C9 ROAD WHEEL AND TIRES.
- Check if wheel bearing axial end play is within specification.
- Check wheels for deformation.
- Check suspension ball joint for play.
- Check if shock absorbers operate properly.
- Check axle and suspension for looseness or deformation.
- Check if vehicle posture is normal.
- Check suspension link for damage, cracks or deformation.
- Check that vehicle is unladen*.

* (Unladen: Fuel, radiator coolant and engine oil full. Spare tire, jack, hand tools and mats in designated positions.

Operation sequence

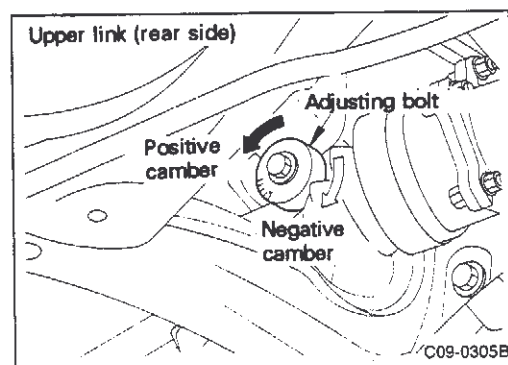
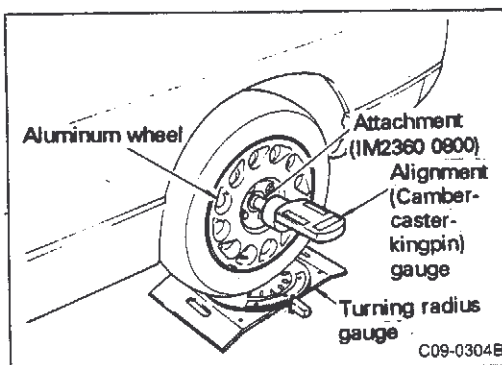
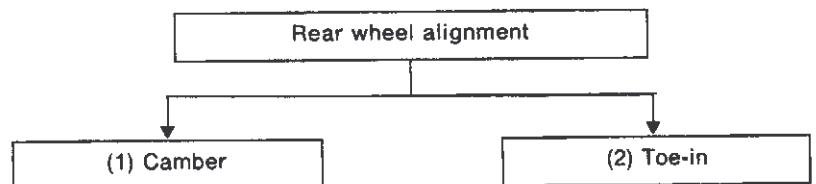

(1) Camber inspection and adjustment

Move vehicle so rear wheels rest on turning radius gauge correctly and check that vehicle is horizontal.

Raise front wheels on stand so they are the same height as rear wheels.

Attach alignment gauge to wheel and measure camber. (Note)

Note: The same attachment can be used for both the front and rear wheels.

Specification:

If camber is not within specification: Camber: $-0^{\circ}55' \pm 30'$

Adjust camber.

Turn adjusting bolt on upper link (rear side) suspension member to adjust camber.

Adjustment must always be made after camber and toe-in adjustment.

C8 REAR SUSPENSION AND AXLE

2. On-vehicle Inspection and Preparation (Cont'd)

(2) Toe-in inspection and adjustment

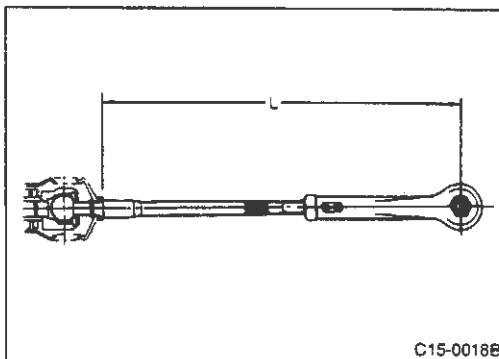
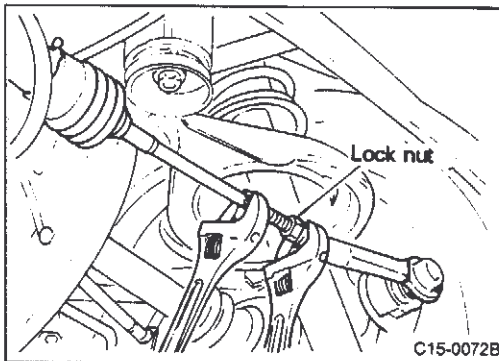
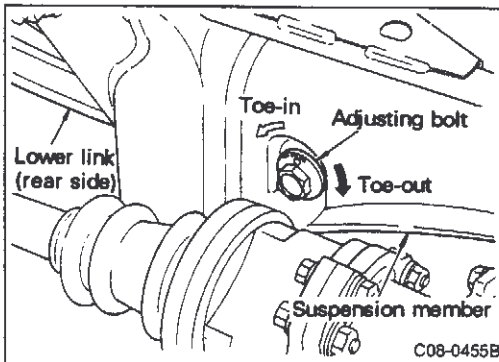
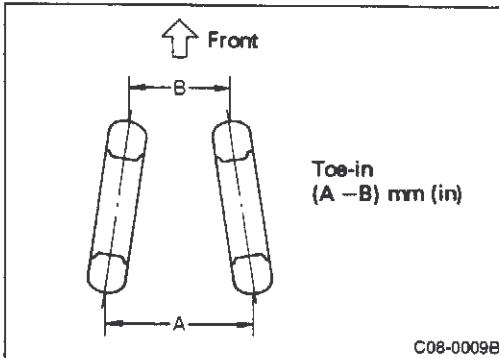
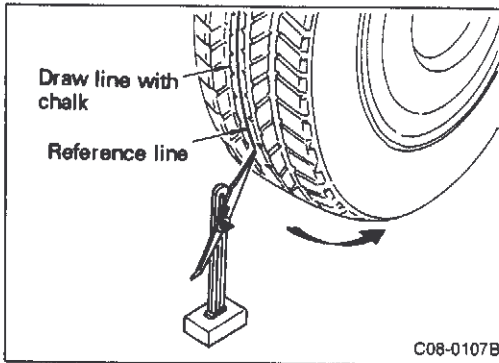

Jack up rear of vehicle and draw a base line on the tread.

After lowering rear of vehicle, move it up and down to eliminate friction.

Set toe-in gauge at same height as wheel center and measure reference line distance.

Measure dimensions A and B as shown in figure and calculate toe-in.
Toe-in = A - B mm (in)

Toe-in standard value:
 2 ± 2 mm (0.08 ± 0.08 in)

If not within specification:

Turn lower link (rear side) suspension member (adjusting bolt) to adjust toe-in.

For models equipped with SUPER HICAS system, loosen lock nut and turn power cylinder lower link toe adjustment rod as shown in figure to adjust toe-in.

CAUTION:

(1) When adjusting lower link, turn left and right rods same distance.

(2) When replacing lower link rod, set rod length as indicated below to adjust toe-in.

For models equipped with SUPER HICAS system, set power cylinder lower link length to following specification before toe-in adjustment.

Lower link standard dimension (L) :
309.4 mm (12.18 in)

C8 REAR SUSPENSION AND AXLE

3. Removal and Installation, Assembly and Disassembly

3-1 REAR SUSPENSION

(1) Removal and installation from vehicle

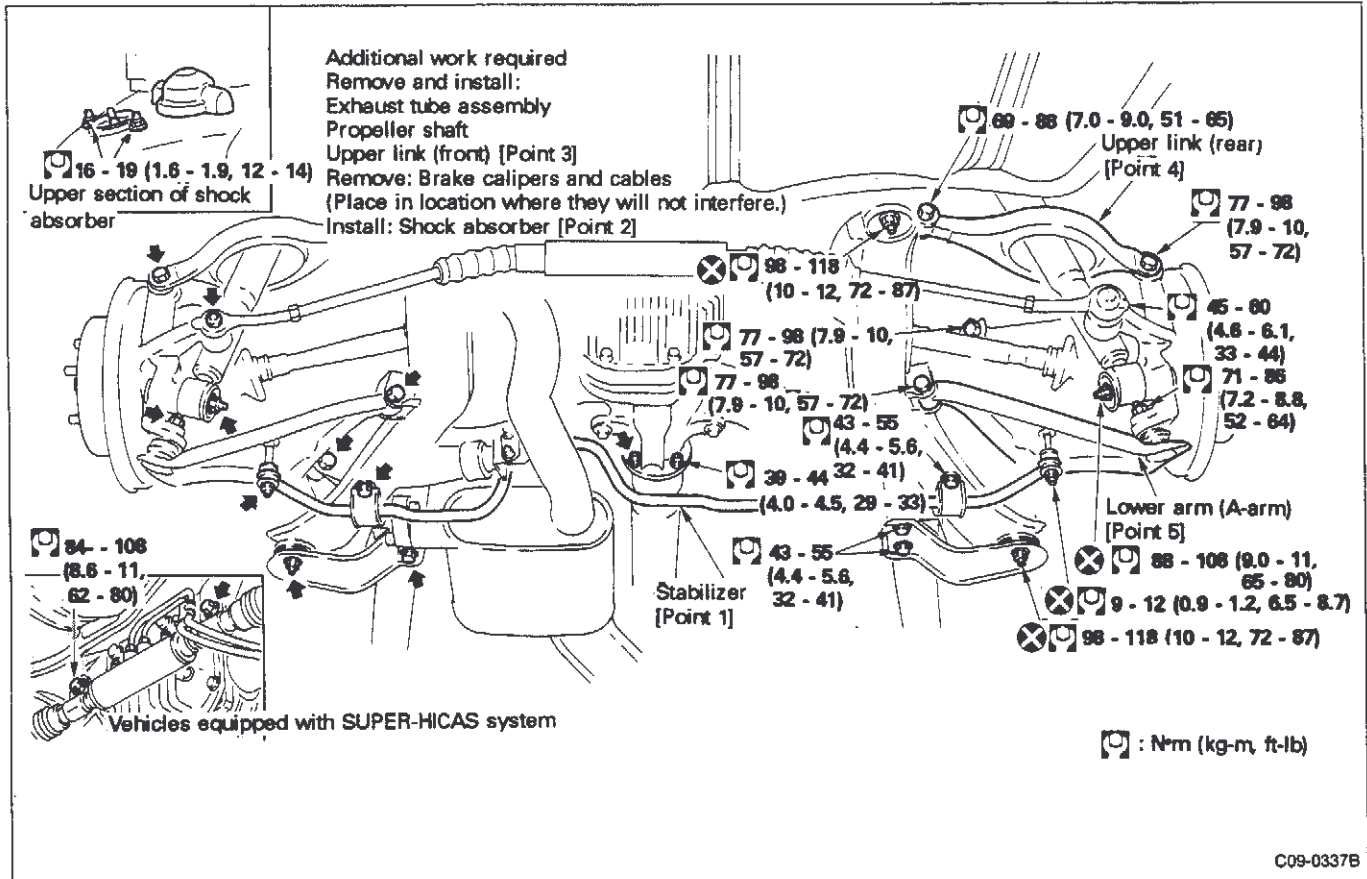

CAUTION:

- (1) Tighten links temporarily on vehicle and then tighten again with vehicle in unladen condition.
- (2) Do not press on brake pedal when brake caliper assembly and brake drum are removed.

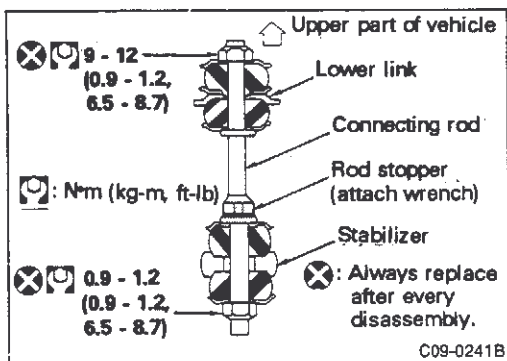

[Point 1] Stabilizer installation

- Assemble stabilizer on connecting rods as shown in figure.

C8 REAR SUSPENSION AND AXLE

3. Removal and Installation, Assembly and Disassembly (Cont'd)

[Point 2] Rear shock absorber installation

- Install shock absorber with large inner diameter lower bushing side facing outside of vehicle. (The figure on left is a cross-section of left side shock absorber viewed from above.)

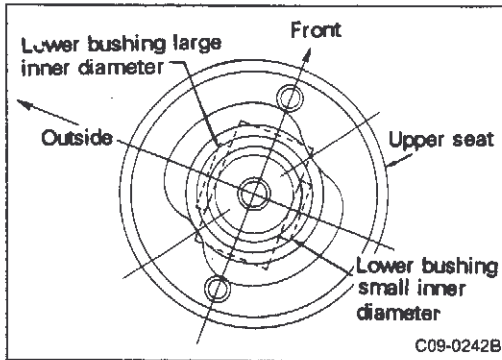

[Point 3] Upper link (front) removal and installation

Removal

- To remove upper link (front), first remove bolts from upper link (rear) rear housing then remove bolts from upper link (front) rear housing.
- Remove suspension member.

CAUTION:

Do not remove link bushing from link.

Installation

- Assembly is reverse sequence from disassembly.

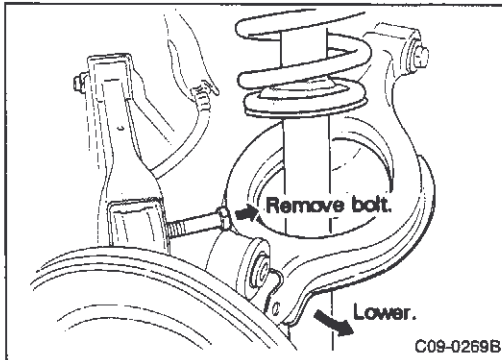

[Point 4] Upper link (rear) removal and installation

Removal

- Remove lower side of rear shock absorber.
- Remove bolts from upper link (rear) (on both rear housing and suspension member).
- Press shock absorber towards inside of vehicle and lower it without touching rear housing.

CAUTION:

Place cloth on drive shaft boot to protect it from damage during removal and installation.

Installation

- Assembly is the reverse sequence from disassembly.

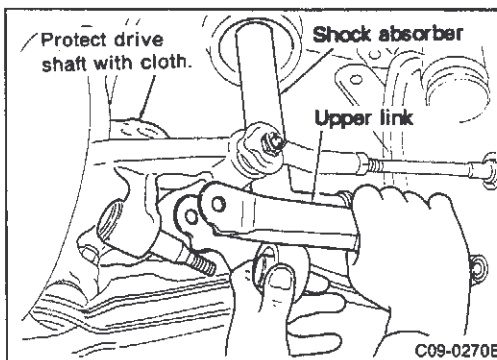

C8 REAR SUSPENSION AND AXLE

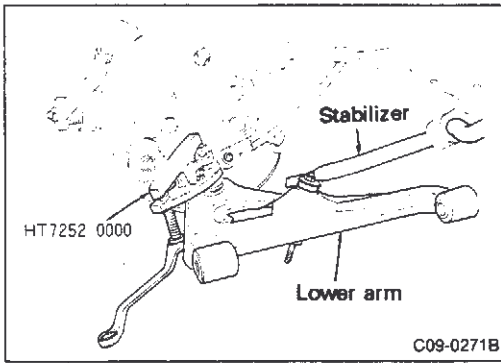

3. Removal and Installation, Assembly and Disassembly (Cont'd)

[Point 5] Lower arm (A arm) removal and installation

Removal

- Remove lower side of stabilizer connecting rod and bracket.
- Remove drive shaft.
- Remove suspension member bolts.
- Use ball joint remover (commercial service tool) to for rear housing separation.

CAUTION:

- (1) Do not damage ball joint boot.
- (2) Do not remove link bushing from link.

Installation

- Assembly is the reverse sequence from disassembly.

CAUTION:

Check wheel alignment after link removal and installation.

C8 REAR SUSPENSION AND AXLE

3. Removal and Installation, Assembly and Disassembly (Cont'd)

(2) Rear suspension disassembly

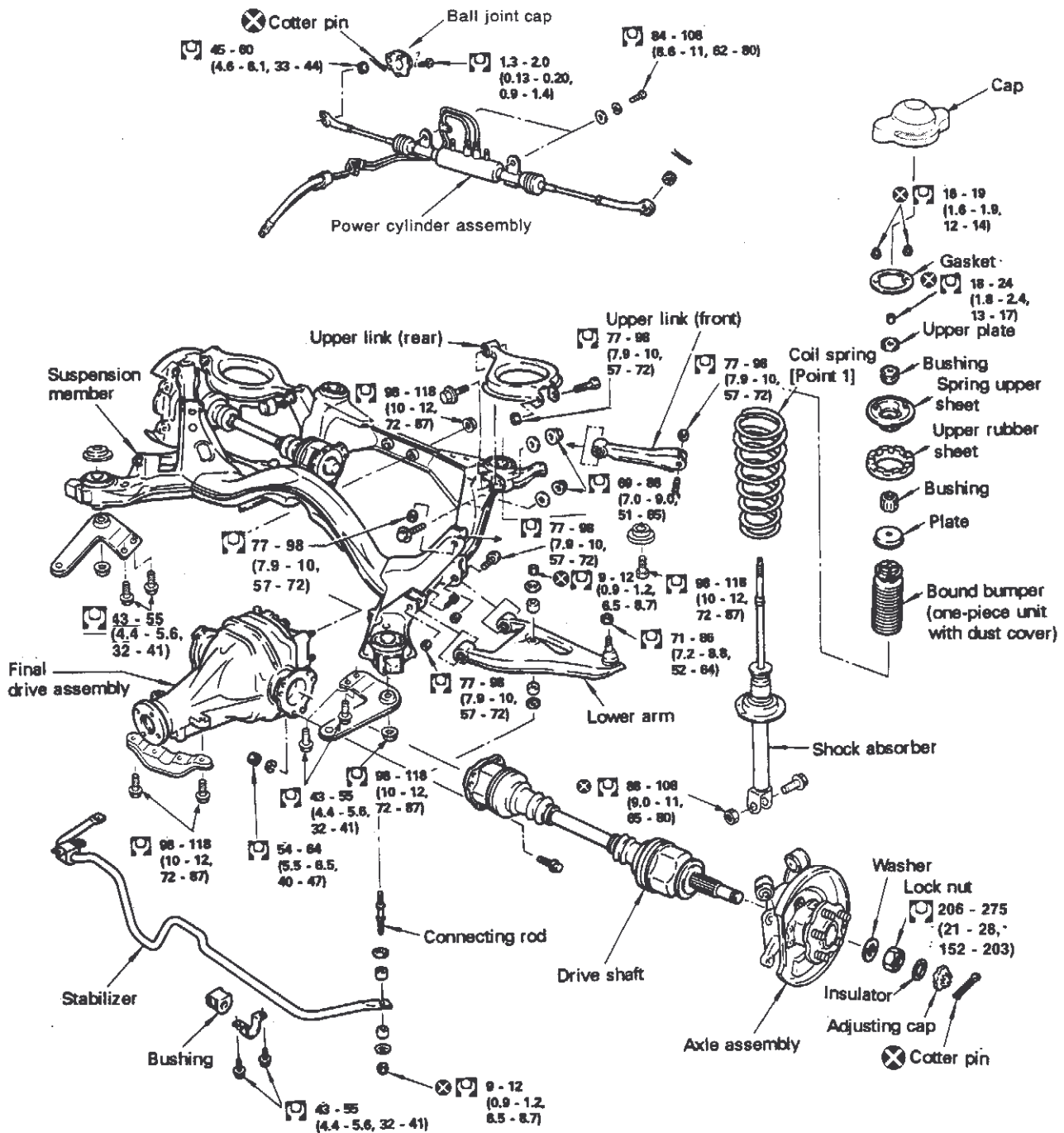

- After installing each suspension part, check and adjust wheel alignment
- Make sure bushing and washer are installed in correct direction.
- Do not let grease or oil contact bushing.
- When stabilizer and link are installed, tighten parts with vehicle on level ground in unladen condition.
- Do not replace suspension side bushing of upper link and lower arms (link). Only replace axle bushing when necessary.
- The suspension member insulator cannot be disassembled.

Additional work required
 Install: Exhaust tube assembly
 Propeller shaft
 Parking brake cable
 Brake calipers
 Inspect each part [Point 2]

- ⊗: Always replace after every disassembly.
- Ⓜ: Nm (kg-m, ft-lb)

C8 REAR SUSPENSION AND AXLE

3. Removal and Installation, Assembly and Disassembly (Cont'd)

[Point 1] Coil spring removal and installation

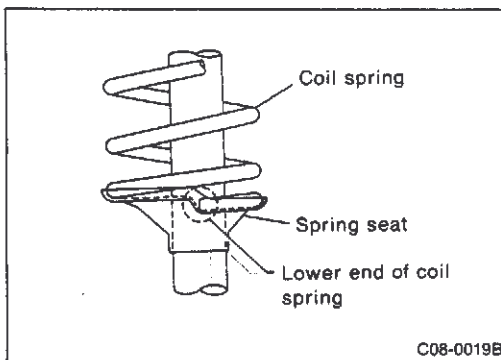
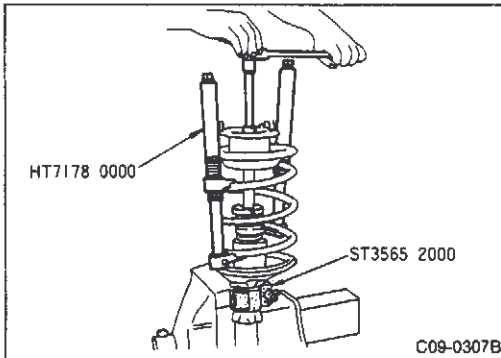
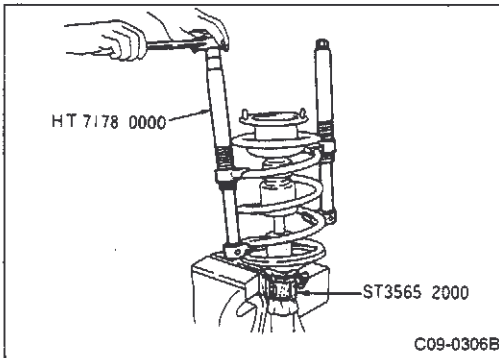

Removal

- Install attachment (special service tool) to strut assembly and secure in vice.
- Using spring compressor (commercial service tool), compress coil spring.

- Remove piston rod lock nut without damaging piston rod.

CAUTION:

Compress coil spring. Make sure it is free between the upper sheet and lower sheet and then remove piston rod lock nut.

Installation

- Check that spring is set securely in spring sheets and gradually loosen spring compressor (commercial service tool).

[Point 2] Inspection

① Coil spring

- Check for cracks and deformation and replace if necessary.

② Rear suspension member

- If suspension member is cracked or deformed or member insulator is damaged, replace member assembly.

③ Upper and lower links

- If upper and lower links are deformed or cracked or bushing is damaged, replace each link.

④ Suspension lower ball joint

- Measure ball joint swing torque, sliding torque and axial end play. The measurements are the same as for the front suspension lower.

C8 REAR SUSPENSION AND AXLE

3. Removal and Installation, Assembly and Disassembly (Cont'd)

3-2 REAR AXLE REMOVAL AND INSTALLATION, ASSEMBLY AND DISASSEMBLY

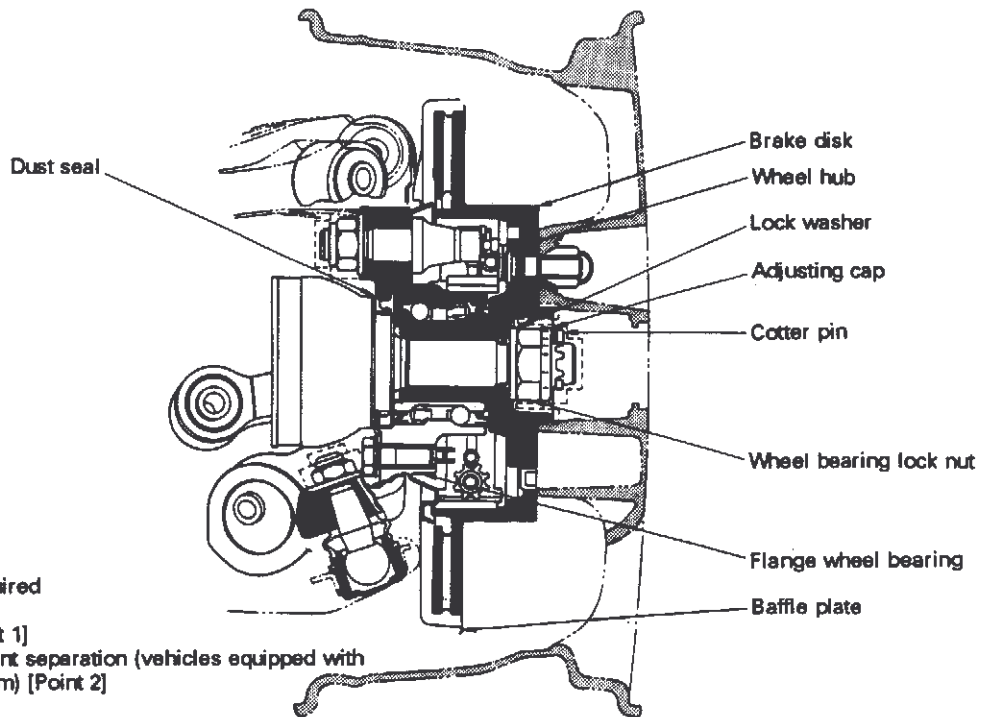
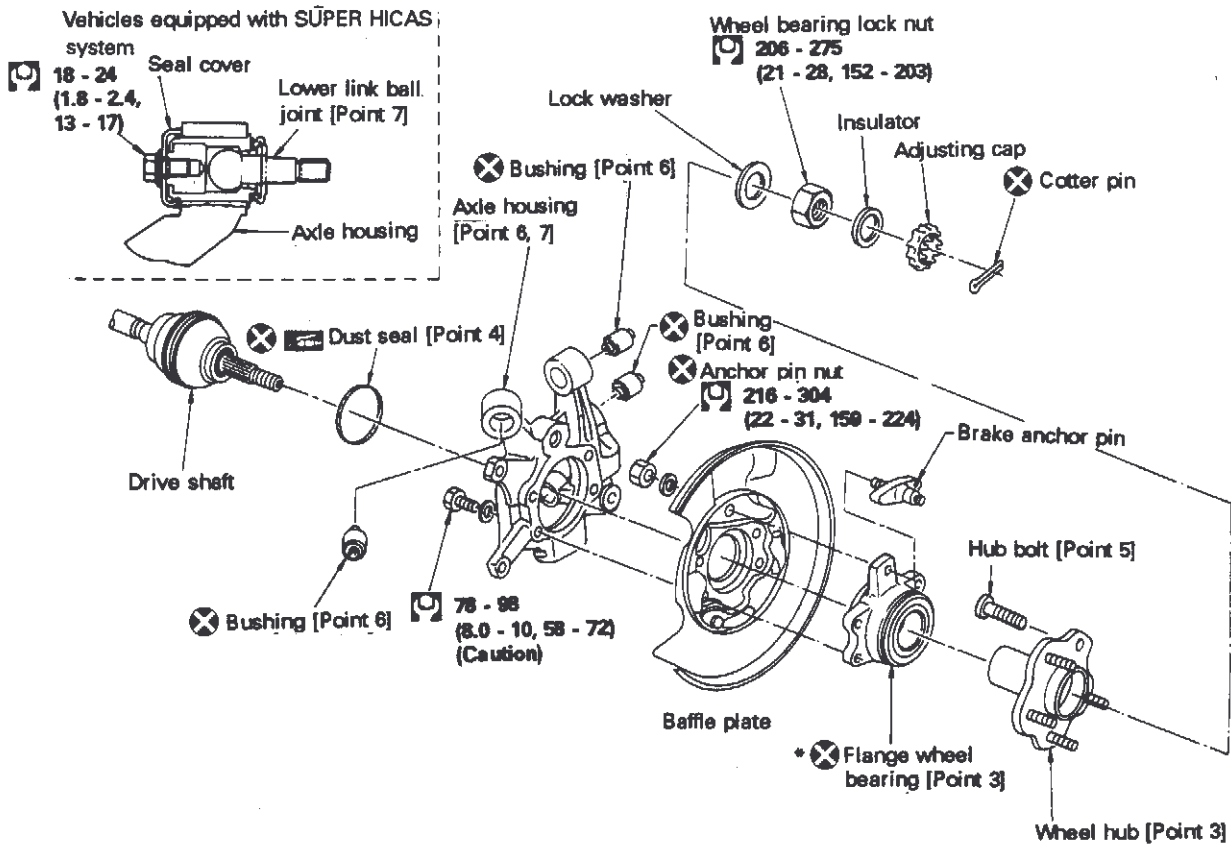

Additional work required
 Remove and install:
 Brake calipers [Point 1]
 Axle housing ball joint separation (vehicles equipped with SUPER HICAS system) [Point 2]
 Shock absorber unit
 Inspect all installed parts [Point 8]

: N·m (kg·m, ft·lb)

: Always replace after every disassembly.

: Apply Nissan MP special grease No. 2

* Replace as set.

CAUTION:

(1) Tighten bolts in criss-cross pattern 2-3 separate times.

(2) Conditions are same as for NES standard bolts. Pay attention not to make mistakes because strength varies.

C09-0355B

C8 REAR SUSPENSION AND AXLE

3. Removal and Installation, Assembly and Disassembly (Cont'd)

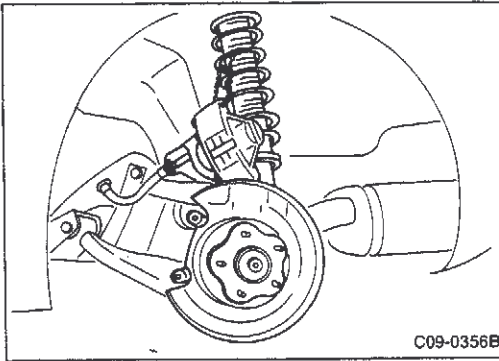

[Point 1] Brake caliper separation

- Remove caliper from axle housing. Set it where it will not cause interference. (It is not necessary to remove brake cable.)

CAUTION:

Do not press brake pedal while brake caliper assembly is removed.

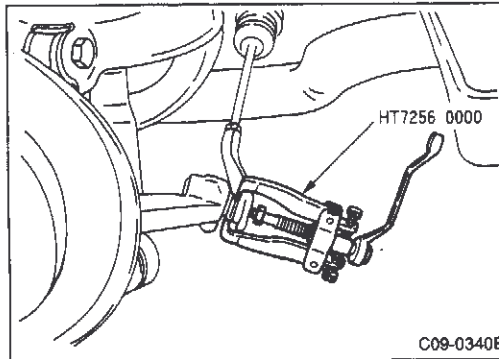

[Point 2] Lower link and ball joint separation

- Use Pitman arm puller (commercial service tool) to separate axle housing ball joint and lower link.

[Point 3] Wheel bearing removal and installation

- Wheel bearing with flange does not require maintenance. If any of the following symptoms are noted, replace wheel bearing assembly (including inner and outer grease seals.)
 - ① Wheel bearing makes growling noise during operation.
 - ② Wheel bearing drags or turns roughly when hub is turned by hand after bearing lock nut is tightened to specified torque.
 - ③ After wheel bearing is removed from hub.

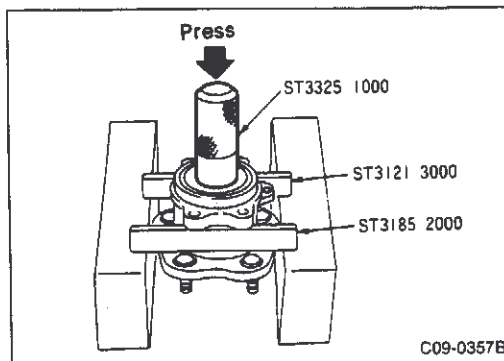

Removal

- Separate wheel bearing with flange and wheel hub from axle housing and wheel hub assembly.
- Set wheel bearing in press as shown in figure. Use drift (special service tool) to remove bearing.
- Replace bearing assembly with new unit. Do not reuse old bearing.

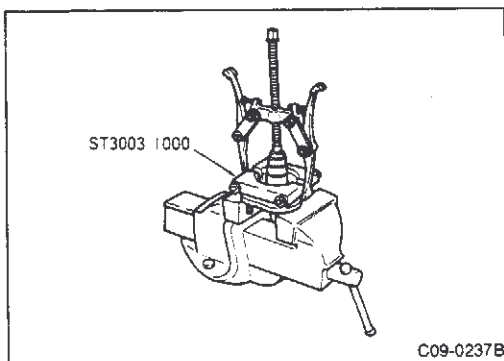

- Set bearing replacer (special service tool) on inner race remaining on hub as shown in figure. Using puller (commercial service tool), remove inner race.

CAUTION:

- (1) Never use the inner race remaining on hub again.
- (2) Discard old wheel bearing assembly. Replace with new part. (The grease seal is not available as an individual part).

C8 REAR SUSPENSION AND AXLE

3. Removal and Installation, Assembly and Disassembly (Cont'd)

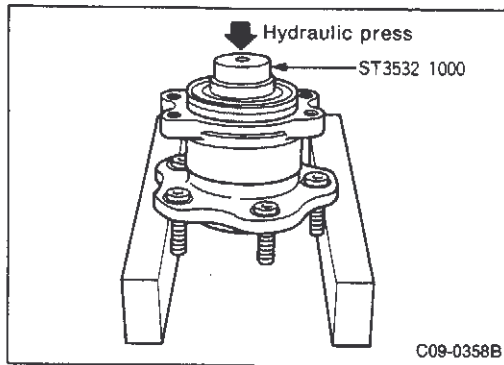

Installation

- Leave hub on block, and position drift (special service tool) and wheel bearing on flange as shown in figure. Use hydraulic press to press-fit bearing.

[Point 4] Axle housing dust seal removal and installation

Removal

- Using drift (special service tool) and hammer, press out dust seal.

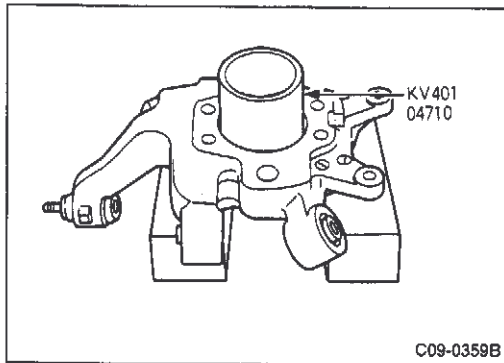

Installation

- Using drift (special service tool), press-fit dust seal with hydraulic press.

CAUTION:

Coat dust seal lip with Nissan MP special grease No. 2.

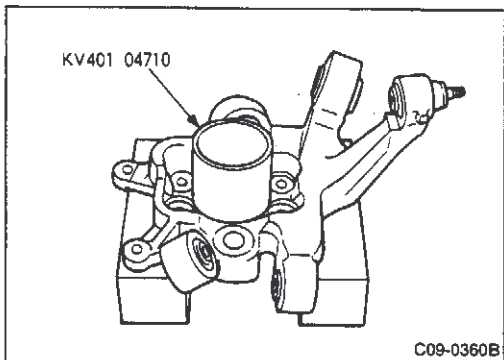

[Point 5] Hub bolt replacement

Removal

- To replace hub bolts, first remove brake caliper assembly, disk rotor and brake shoes. Operation can then be performed on vehicle.

CAUTION:

Do not remove hub and wheel bearing.

- Use ball joint remover (commercial service tool) as shown in figure.

CAUTION:

Do not hit hub bolts with hammer. (This will apply impact to wheel bearings.)

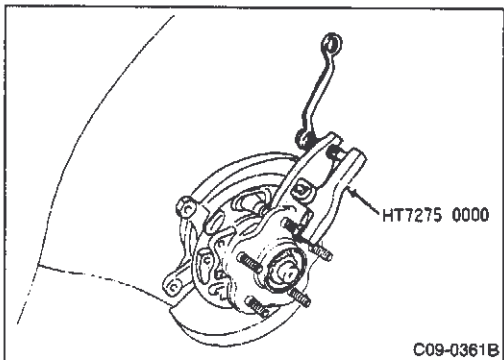

C8 REAR SUSPENSION AND AXLE

3. Removal and Installation, Assembly and Disassembly (Cont'd)

Installation

- To press-fit hub bolts, insert washers as shown in figure and tighten bolts.
- When replacing a single hub bolt, use new bolt with same identification number.

Hub bolt identification number	43222 06R61
--------------------------------	-------------

CAUTION:

After replacing hub bolt, check that disk runout is 0.07 mm (0.0028 in) maximum.

[Point 6] Axle housing bushing removal and installation

Bushing removal and installation precautions

- Do not secure axle housing mechanical unit directly in vise. Protect housing with wood panels or rags before tightening vise.
- Install attachment described in previous operation.

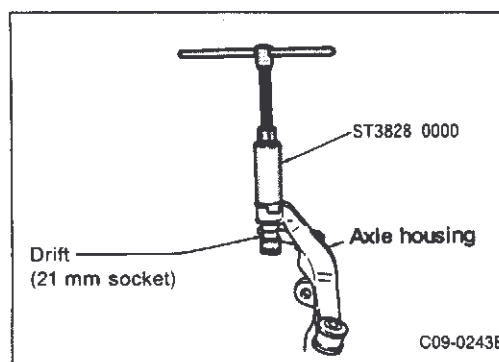
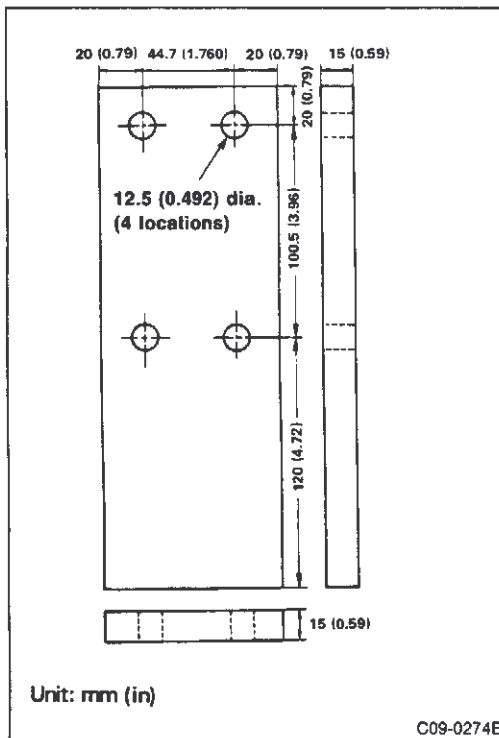
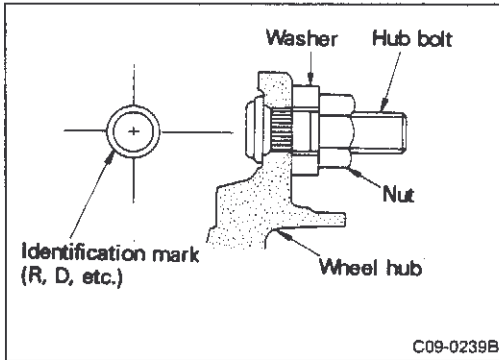

Removal

- Attach drift and socket (21 mm) on outer shell of as shown in figure and use arm bushing remover (special service tool) to remove bushing.

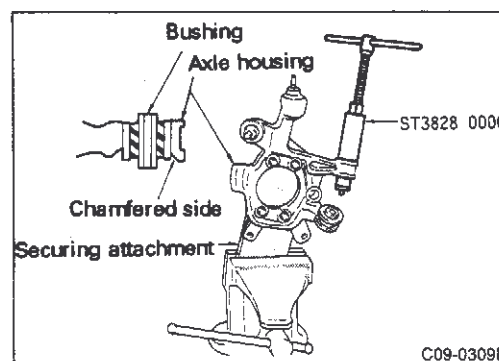

Installation

- Make sure that axle housing bore is free from scratches or deformities before pressing bushing into it.
- Lubricate bushing with detergent.
- Set arm bushing remover (special service tool), insert from direction of axle housing bore chamfering and press-fit bushing flush with end surface.

C8 REAR SUSPENSION AND AXLE

3. Removal and Installation, Assembly and Disassembly (Cont'd)

Axle housing bushing (shock absorber) removal and installation

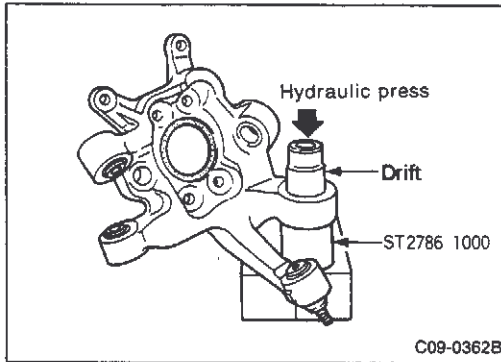

Removal

- Set drift (special service tool) on lower side of axle housing as shown in figure. Set drift [inner diameter 37 mm (1.46 in), outer diameter 45 mm (1.77 in)] on upper side and press out bushing.

CAUTION:

Check bushing position before removal.

Installation

- Install bushing using same tools as for removal. Assembly is reverse sequence from disassembly.

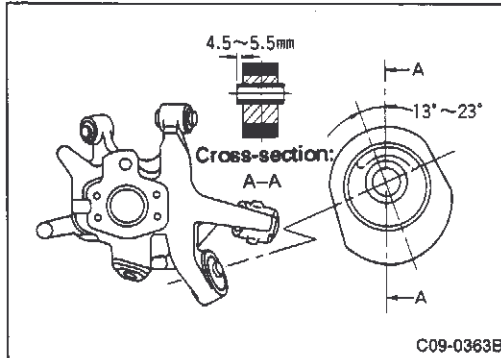

[Point 7] Axle housing and lower link ball joint separation

Removal

- Remove ball joint seal cover.
- Set drift [inner diameter 37 mm (1.46 in), outer diameter 40 mm (1.57 in)] on rear side of axle housing as shown in figure. Set drift [inner diameter 23 mm (0.91 in), outer diameter 27 mm (1.06 in)] on front side of axle housing as shown in figure and press out ball joint.

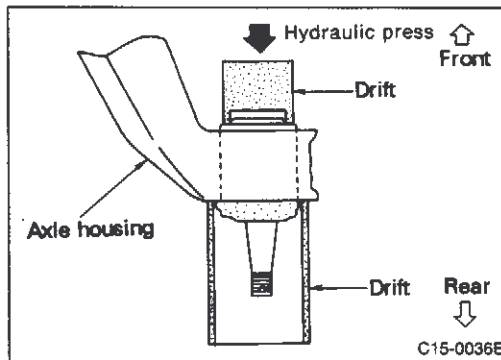

Installation

- Set drift [inner diameter 29 mm (1.14 in), outer diameter 35 mm (1.38 in)] on rear side of axle housing as in removal. Set drift [inner diameter 31 mm (1.22 in), outer diameter 41 mm (1.61 in)] on front side of axle housing and press-fit ball joint.
- Install seal cover.

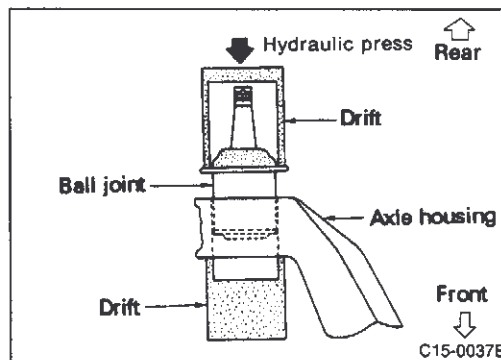

[Point 8] Inspection

- Inspect all parts and replace if following items are noticed.
 - ① Check ball bearings for damage, seizing, rust and rotation.
 - ② Check wheel hub for cracks. (Use dyeing damage analysis method.)
 - ③ Check axle housing for dents, deformities and cracks. (Use dyeing damage analysis method.)

C9 WHEELS AND TIRES

1. Summary

Specifications

Wheels					Suitable tire size	Remarks
Rim size	Material (color)	Offset mm (in)	Hub bolts P.C.D. mm (in) × number of bolts	Hub hole diameter mm (in)		
16 × 8 JJ 16 × 6 1/2JJ (for snow)	Aluminum (silver)	30 (1.18)	114.3 (4.50) × 5	66 (2.60)	225/50R16 92V 205/55R16 88V (for snow)	Models equipped with RB26DETT
16 × 4T (spare tire for emergency use)	Steel (yellow)	20 (0.79)			T125/90D16	Models equipped with RB26DETT

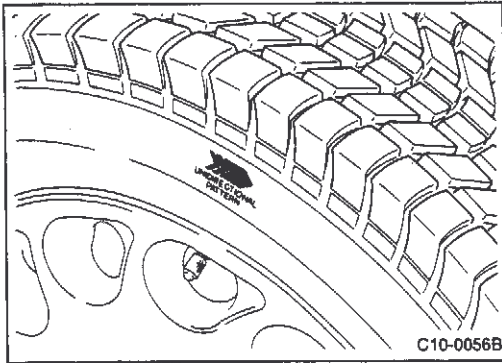

2. Wheels

2-1 INSTALLATION ON VEHICLE

- An arrow mark on tire as shown in figure indicates that a directional tread is used. The tire must be mounted so it turns in the indicated direction.

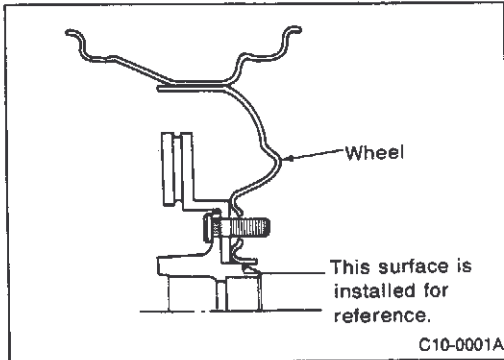

- Place holes in middle of wheel (hub holes) on bolts and tighten to install.

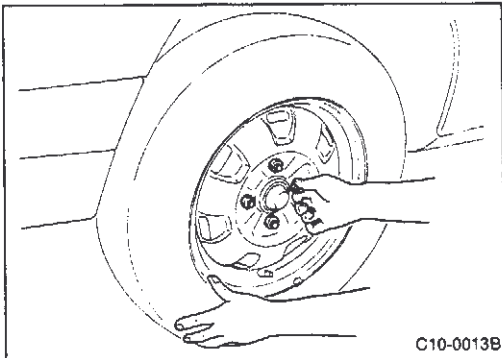

- Tighten lug nuts by hand.

CAUTION:

The tapered side of the lug nut must face the wheel.

- Rotate tire by hand and tighten again by hand.

C9 WHEELS AND TIRES

2. Wheels (Cont'd)

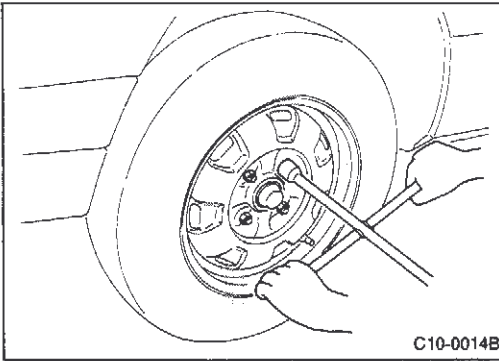

- While rotating tire and changing position, tighten with tool (If wheel is loose, tighten slightly less than specified torque until wheel does not move.)

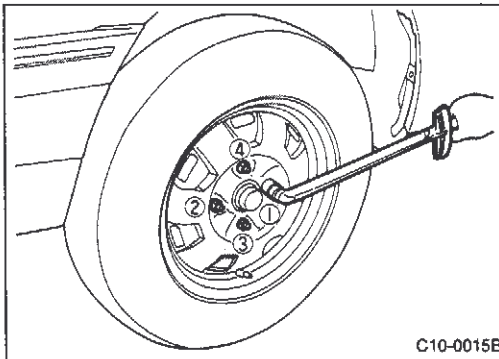

- Lower vehicle to ground and tighten to specified torque. (Tighten wheel evenly in criss-cross pattern 2 - 3 times.)

Wheel tightening torque:

98 - 118 N·m (10 - 12 kg-m, 72 - 87 ft-lb)

CAUTION:

When using straight cone to balance wheels, check that vertical installation position on vehicle is the same when set on balancer.

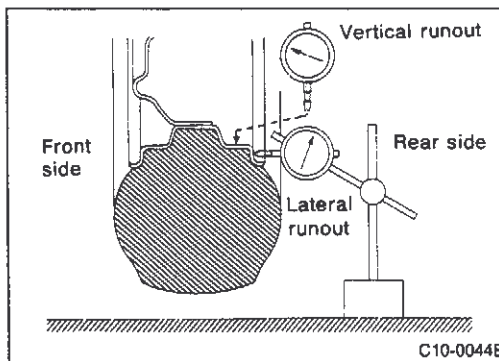

- Check wheel runout.

	Lateral runout limit	Vertical runout limit
Steel wheel	0.8 mm (0.031 in) max.	0.5 mm (0.020 in) max.
Aluminum wheel	0.3 mm (0.012 in) max.	

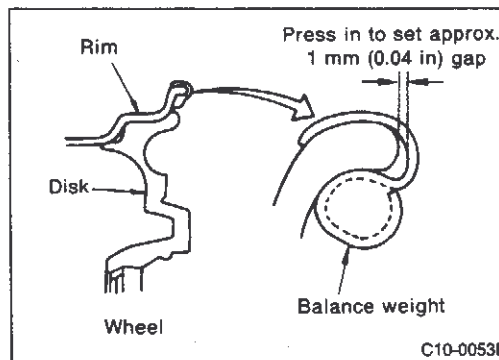

2-2 WHEEL BALANCE ADJUSTMENT

- Use straight cone type attachment to adjust the wheel balance.
- Be sure to attach cone to rear side of aluminium and steel wheels at this time with wheel balancer.
- When using regular taper cone to adjust steel wheel, support wheel from front.

CAUTION:

- (1) Always use genuine Nissan balance weights.
- (2) Always use plastic coated balance weights for aluminium wheels.
- (3) Do not reuse balance weights.
- (4) Always use plastic hammer to hit weights.

Unit: g (o

Allowable remaining unbalance amount	Dynamic (on ear)	10 (0.35) max. (one side)
	Static (on ear)	20 (0.71) max.
Balance weight maximum correction amount	Steel wheel	60 (2.12)
	Aluminum wheel	60 (2.12)

C9 WHEELS AND TIRES

2. Wheels (Cont'd)

2-3 ALUMINUM ROAD WHEEL INSTALLATION PRECAUTIONS

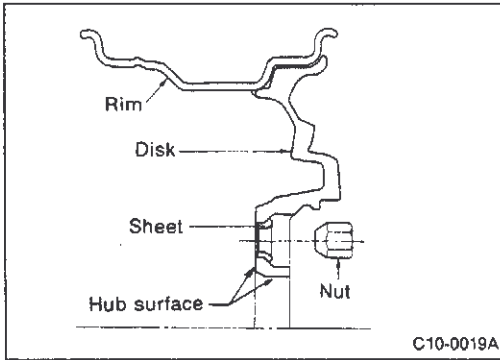

- Nissan aluminum wheels are specifically designed for a particular vehicle and should not be used on other vehicles.
- Use genuine Nissan taper nuts because the steel sheet is press-fitted in the wheel disk holes.
- Always balance wheels before use. Only use genuine Nissan plastic coated weights for wheel balancing.
- Be careful during balancing because aluminum wheels scratch easily. Do not use abrasive cleanser or wire brush to clean off dirt. Only use neutral detergent for cleaning.
- Avoid using high-speed car washing equipment.
- After driving on roads which have salt deposits to prevent icing and roads close to the ocean, wash off accumulated dirt with water.
- Wash off back side of wheel when tires are exchanged or washing bottom of vehicle.
- Wipe off dirt and foreign matter from hub surface before installing wheels.
- Never coat wheels, nut threads or nut seats with oil.
- Do not drive on sharp objects, curbs or sidewalks.

3. Tires

3-1 TIRE INFLATION PRESSURE AND WEAR LIMITS

- The tire inflation pressure are indicated for cold tire conditions [after parking for more than three hours or driving less than 1.6 km (1 mile)].
- Check tire pressure once a month or before driving long distances.

CAUTION:

The tire pressure rises to 29 kPa (0.3 kg/cm², 4 psi) during driving. Do not remove air to lower tire pressure immediately after driving.

Tire size	Inflation pressure kPa (kg/cm ² , psi)	
	Front wheels	Rear wheels
205/55R16 88V	216 (2.2, 31)	216 (2.2, 31)
225/50R16 92V	226 (2.3, 33)	226 (2.3, 33)
T125/90D16	412 (4.2, 60)	412 (4.2, 60)

CAUTION:

The tire inflation pressure is the same for high-speed driving as it is for normal driving.

Tread wear limit:

Remaining groove depth 1.6 mm (0.063 in)

C10 BRAKES

PRECAUTIONS

- Recommended brake fluid is brake fluid NR-3 (No. 2500).
- Never reuse drained brake fluid.
- Be careful not to splash brake fluid on painted areas because it may cause paint damage. If brake fluid is splashed on painted areas, wipe it off immediately.
- For safety reasons, if any brake fluid leak is discovered, disassemble parts and replace as necessary.
- Use brake tube torque wrench (special service tool) to loosen or tighten brake pipe flare nuts.

SPECIAL SERVICE TOOLS

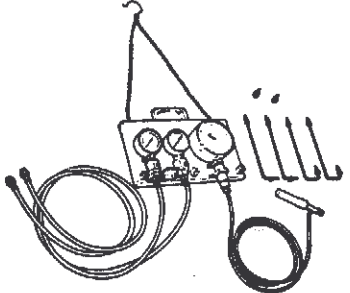
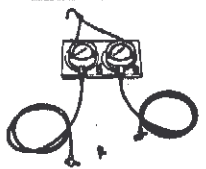
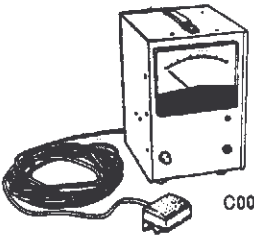
Tool name Tool number	Description
Brake tube torque wrench GG9431 0000	 <p style="text-align: right;">C00-0002</p> <ul style="list-style-type: none"> ● Removing and installing brake tube piping
Booster tester set KV991 019S0 KV991 01910 KV991 01920 KV991 01930 KV991 01940 KV991 01950 EG1521	 <p style="text-align: right;">C00-0031</p> <ul style="list-style-type: none"> ● Measuring booster pressure ● Measuring brake fluid pressure
Brake fluid pressure gauge KV991 V0010	 <p style="text-align: right;">C00-0034</p> <ul style="list-style-type: none"> ● Measuring brake fluid pressure
Pedal pressure gauge IM2182	 <p style="text-align: right;">C00-0032</p> <ul style="list-style-type: none"> ● Measuring brake pedal pressure force

C10 BRAKES

1. Summary

Specifications

Description		Engine	RB26DETT
		Anti-lock braking system	Equipped
Main brake	Front	Model number	OPZ25VR
		Disc outer diameter/thickness	mm (in) 296/32 (11.65/1.26)
		Pad dimension (length × width × thickness)	116 × 50 × 10 (4.57 × 1.97 × 0.39)
		mm (in)	
		Cylinder inner diameter	mm (in) 40.4 × 2 (1.591 × 2)
		Pad material	AP50H
	Pad wear warning equipment	Equipped	
	Rear	Brake model	OPZ11VB
		Disc outer diameter thickness	mm (in) 297/18 (11.69/0.71)
		Pad dimension (length × width × thickness)	71.8 × 36.5 × 11.5 (2.827 × 1.437 × 0.453)
		mm (in)	
		Cylinder inner diameter	mm (in) 38.1 (1.500)
Pad material		AP50	
Pad wear warning equipment	Equipped		
Parking brake	Model number	DS17HD	
	Drum inner diameter	mm (in) 172 (6.77)	
	Lining dimension (length × width × thickness)	154.1 × 25.0 × 3.0 (6.07 × 0.984 × 0.118)	
	mm (in)		
	Lining material	AKD201	
Lining gap adjustment dimension	Manual adjustment		
Master cylinder	Cylinder inner diameter	mm (in) 25.40 (1)	
Power booster	Booster	Model number	M215T (JKC)
		Diaphragm diameter	205 + 230 (8.07 + 9.06)
Rear control equipment	Model number	Proportioning valve (one-piece, contained in master cylinder)	
	Split point	kPa (kg/cm ² , psi) 1,961 (20, 284)	
	Reducing ratio	0.4	
Recommended brake fluid	Nissan brake fluid NR-3 (No. 2500)		

C10 BRAKES

1. Summary (Cont'd)

Inspection and adjustment

Description		Specification											
Brake pedal	Free height (above floor) mm (in)	M/T: 172.5 - 182.5 (6.79 - 7.19)											
	Depressed [under force of 490N (50 kg, 110 lb)] with engine running (measured from top of dash panel) mm (in)	85 (3.35) max.											
	Clevis pin play (measured at pedal upper surface) mm (in)	1 - 3 (0.04 - 0.12)											
	Play mm (in)	3 - 11 (0.12 - 0.43)											
	Stop lamp switch screw end and pedal stopper clearance mm (in)	0.3 - 1.0 (0.012 - 0.039)											
Brake application conditions [Depressed force 883 N (90 kg, 198 lb)] OPZ25VR model + OPZ11VB Note: (1) The indicated values are intended for reference to determining control force after inspection preparation. (2) The term "after preparation" means the condition of braking ten times [speed 40 to 50 km/h → 0 km/h (25 to 31 MPH → 0 MPH)] with a deceleration force of 0.2 to 0.3 G for break-in after replacing lining and pad replacement, or after cleaning and sandpaper lapping of drums and shoes. (0.2 to 0.3 G indicates a control force stronger than normal braking.)		<table border="1" style="width: 100%; border-collapse: collapse;"> <thead> <tr> <th colspan="2" style="text-align: left;">Description</th> <th style="text-align: left;">Control force after preparation (Note 2)</th> </tr> </thead> <tbody> <tr> <td rowspan="2" style="vertical-align: top;">Each wheel</td> <td>Total left + right</td> <td>Front axle: 80% min of axle weight Rear axle: 2.942 N (300 kg, 662 lb) min.</td> </tr> <tr> <td>Difference between left and right</td> <td>8% max of axle weight</td> </tr> <tr> <td colspan="2">Total</td> <td>8.140 N (830 kg, 1,830 lb) min</td> </tr> </tbody> </table>	Description		Control force after preparation (Note 2)	Each wheel	Total left + right	Front axle: 80% min of axle weight Rear axle: 2.942 N (300 kg, 662 lb) min.	Difference between left and right	8% max of axle weight	Total		8.140 N (830 kg, 1,830 lb) min
Description		Control force after preparation (Note 2)											
Each wheel	Total left + right	Front axle: 80% min of axle weight Rear axle: 2.942 N (300 kg, 662 lb) min.											
	Difference between left and right	8% max of axle weight											
Total		8.140 N (830 kg, 1,830 lb) min											
Booster vacuum leak [at force of 66.7 kPa (500 mmHg, 19.69 inHg)] kPa (mmHg, inHg)		3.3 (33.25, 0.98) in 15 sec											
Check valve vacuum leak [at force of 66.7 kPa (500 mmHg, 19.69 inHg)] kPa (mmHg, inHg)		1.3 (13.10, 0.39) in 15 sec											
Disc brake	Pad wear limit minimum thickness mm (in)	2 (0.08)											
	Brake disk wear limit minimum thickness mm (in)	OPZ25VR	30 (1.18)										
		OPZ11VB	16 (0.63)										
	Brake disk runout limit mm (in)	0.07 (0.0028)											
Brake drum	Lining wear limit minimum thickness mm (in)	1.5 (0.059)											
	Drum wear limit (inner diameter) mm (in) DS17HD	173 (6.81)											
Parking brake	Pedal stroke [under force of 196 N (20 kg, 44 lb)] (notches) Center lever type	6 - 8											
	Number of notches when brake warning lamp lights (notches) Center lever type	1 max.											

C10 BRAKES

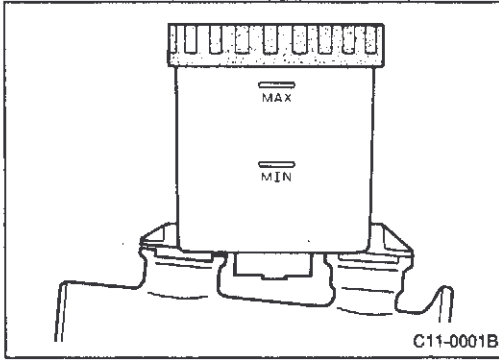

2. On-vehicle Inspection

2-1 CHECKING BRAKE FLUID LEVEL

- Check fluid level in reservoir tank. It should be between Max. and Min. lines on reservoir tank.
- If fluid level is extremely low, check brake system for leaks.

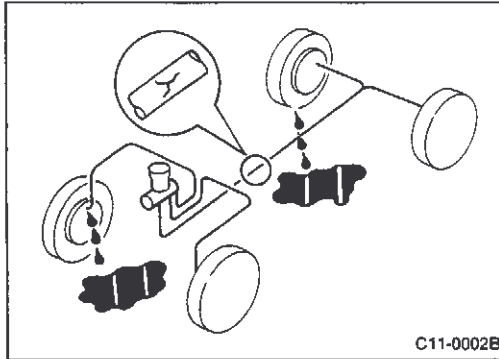

2-2 CHECKING BRAKE SYSTEM

- Check brake lines (tubes and hoses) for leaks, damage, twisting, deterioration or other damage.
- Check if connections and clamps are loose.
Flare nut tightening torque:
15 - 18 N·m (1.5 - 1.8 kg-m, 11 - 13 ft-lb)
- Fully depress brake pedal with force of 785 N (80 kg, 176 lb) for approximately 5 seconds with engine running and check for leaks.

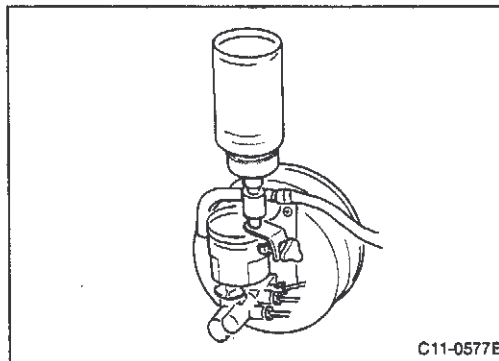

2-3 CHANGING BRAKE FLUID AND AIR BLEEDING

(1) Standard vehicles

- Change brake fluid and air bleeding in the following order.
 - ① Clean inside reservoir tank and fill with new brake fluid.
 - ② Open left rear air bleeder valve.
 - ③ Fully depress brake pedal. Allow pedal to return and depress again after 2 - 3 seconds and repeat this operation.
 - ④ Close rear left wheel air bleeder valve.
 - ⑤ Bleed air from calipers in following order.
Rear right wheel → front left wheel → front right wheel

CAUTION:

- (1) Connect a transparent vinyl tube to air bleeder and be careful fluid does not spill on body.
- (2) Make sure reservoir is filled with brake fluid at all times during air bleeding operation.

- Tighten air bleeder valve to specified torque.

Tightening torque:

7 - 9 N·m (0.7 - 0.9 kg-m, 5.1 - 6.5 ft-lb)

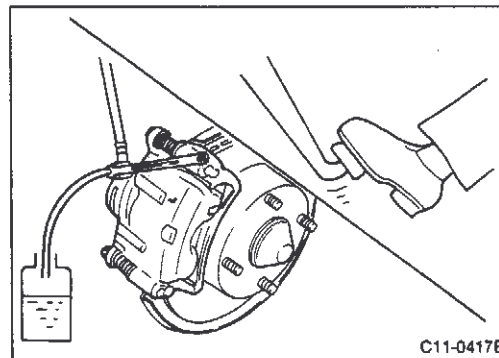

(2) Vehicles equipped with anti-lock braking systems (ABS)

- In vehicles equipped with ABS, bleed air from the following locations in the indicated sequence after performing the procedures described for vehicles with standard brake systems.

Front side actuator bleeder valve → Rear side air bleeder.

CAUTION:

- (1) Air bleeding must be performed after the battery terminal is removed in vehicles equipped with ABS.

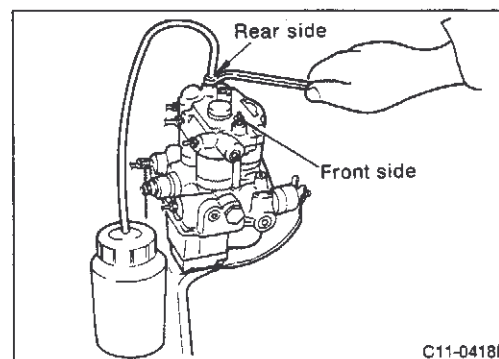

C10 BRAKES

2. On-vehicle Inspection (Cont'd)

- (2) Carefully monitor reservoir brake fluid level during bleeding. Make sure it is more than half-full at all times because air entering brake system may cause operation failure in vehicles equipped with ABS.
- Tighten air bleeder valve to specified torque.
Tightening torque:
7 - 9 N·m (0.7 - 0.9 kg-m, 5.1 - 6.5 ft-lb)

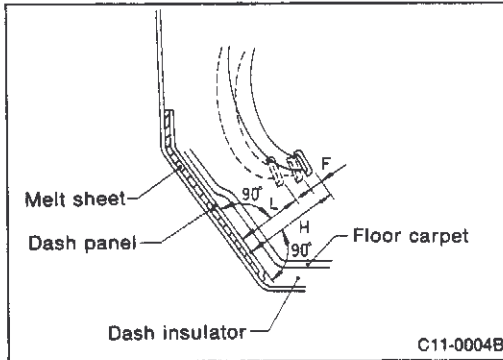

2-4 BRAKE PEDAL INSPECTION AND ADJUSTMENT

Inspection

Unit: mm (in)

Free pedal height "H"	M/T: 172.5 - 182.5 (6.79 - 7.19 in)
Clevis play "F" (from upper pedal surface)	1 - 3 (0.04 - 0.12)
Depressed pedal height "L" Under force or 490 N (50 kg, 110 lb) with engine running	85 (3.35)/min.

When brake pedal is operated, make sure it does not scrap or move abnormally.

- Adjust pedal height as necessary.

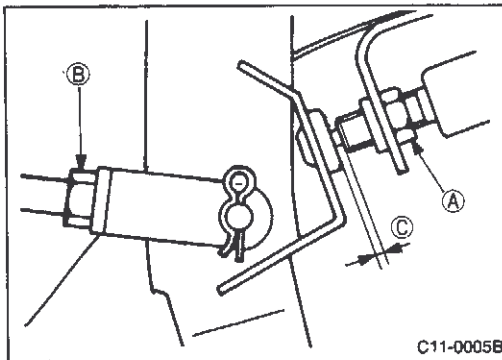

Adjustment

- ① Loosen stop lamp switch lock nut (A).
- ② Loosen push rod lock nut (B), rotate push rod, adjust pedal to specified height and tighten lock nut.
- ③ Rotate switch so clearance (C) between stopper rubber and stop lamp switch thread end is 0.3 to 1.0 mm (0.012 to 0.039 in) and tighten lock nut.

Lock nut tightening torque:

- (A) 12 - 15 N·m (1.2 - 1.5 kg-m, 9 - 11 ft-lb)
- (B) 16 - 22 N·m (1.6 - 2.2 kg-m, 12 - 16 ft-lb)

2-5 VACUUM PIPING INSPECTION

- Apply vacuum to hoses, tubes and connections and make sure there are no scratches, damage or deformation.
- Check that all clamps are tight.
- Check the arrow on check valve E-mark faces engine side.

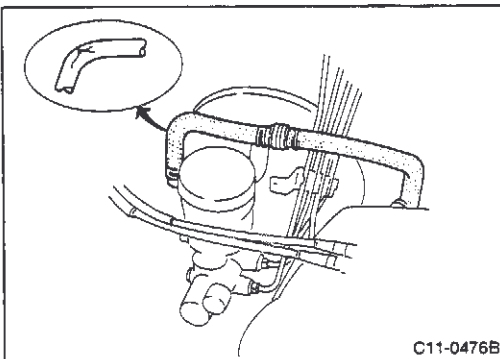

C10 BRAKES

2. On-vehicle Inspection (Cont'd)

2-6 BOOSTER OPERATING CHECK

Operation procedure

- ① Idle engine for approximately one minute. Apply vacuum to booster and turn ignition switch OFF.
- ② Depress brake several times with normal pressure and check for any change in pedal stroke. (A slight change is normal.)
- ③ Depress brake pedal and check that there is no change in pedal height. Turn on engine in this condition and check that pedal goes down. (Moving down is normal.)

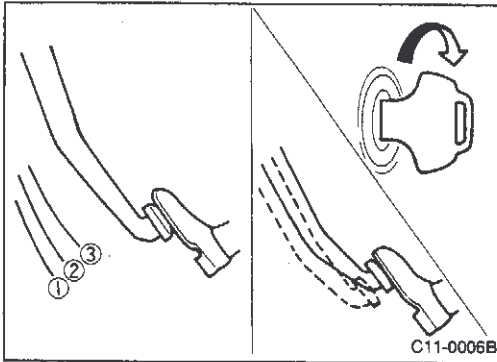

2-7 BOOSTER FUNCTION INSPECTION

Operation procedures

- ① Install special service tools (booster tester set: KV991 019S0, pedal pressure gauge: IM2182) in vehicle.
- ② Start engine and measure vacuum. Stop engine when vacuum reaches 66.7 kPa (500 mmHg, 19.69 inHg).
- ③ Measure lowest vacuum pressure when brake does not operate.
- ④ Measure lowest vacuum pressure when brake is under full load [pedal pressure 245 N (25 kg, 55 lb)].

Specification value (③, ④):

Lowest vacuum level for 15 sec at maximum force of 13.3 kPa (25 mmHg, 0.98 inHg)

- ⑤ Set load in booster to 0 kPa (0 mmHg, 0 inHg) and measure generated hydraulic pressure.
- ⑥ Start engine and measure generated hydraulic pressure when idling [at force of 66.7 kPa (500 mmHg, 69 inHg)]

CAUTION:

- (1) Measure hydraulic pressure on front side.
- (2) Always bleed air from system after measure is completed.

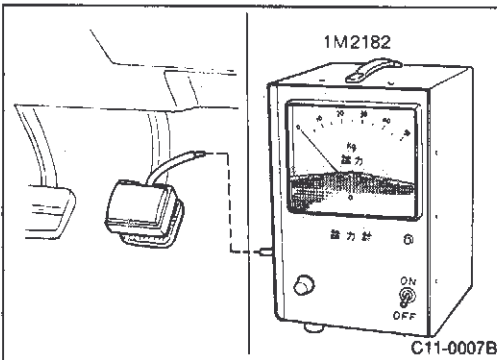
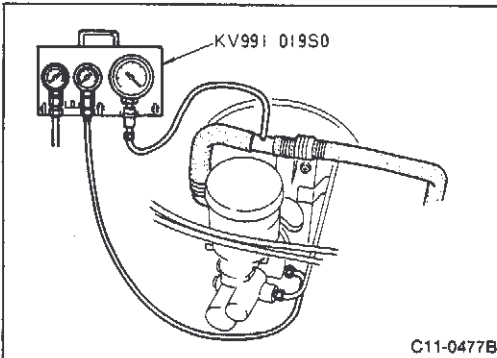

Specification [⑤ : Vacuum 0 kPa (0 mmHg, 0 inHg)]

Pedal pressure N (kg, lb)	Hydraulic pressure kPa (kg/cm ² , psi)
	M215T
98 (10, 22)	0 (0, 0)
196 (20, 44)	392 (4, 57)
294 (30, 66)	1,177 (12, 171)

Specification [⑥ : Vacuum 66.7 kPa (500 mmHg, 19.69 inHg)]

Pedal pressure N (kg, lb)	Hydraulic pressure kPa (kg/cm ² , psi)
	M215T
49 (5, 11)	686 (7, 100)
98 (10, 22)	2,158 (22, 313)
147 (15, 33)	3,825 (39, 555)

C10 BRAKES

2. On-vehicle Inspection (Cont'd)

2-8 BOOSTER AIRTIGHTNESS

- Attach hand vacuum pump (special service tool) as shown in figure.

Specification:

When -66.7 kPa (-500 mmHg, -19.69 inHg) vacuum lowers for 15 sec at maximum of 3.3 kPa (25 mmHg, 0.98 inHg)

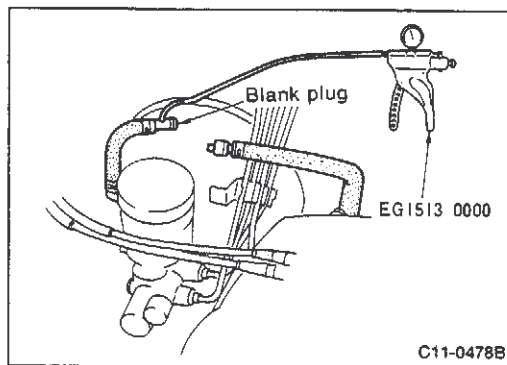

C11-0478B

2-9 CHECK VALVE INSPECTION

- Check vacuum with a vacuum pump.

Connect to booster side ①	Vacuum should exist when -66.7 kPa (-500 mmHg, -19.69 inHg) vacuum lowers for 15 sec at maximum of 3.3 kPa (25 mmHg, 0.98 inHg).
Connect to engine side ②	Vacuum should not exist.

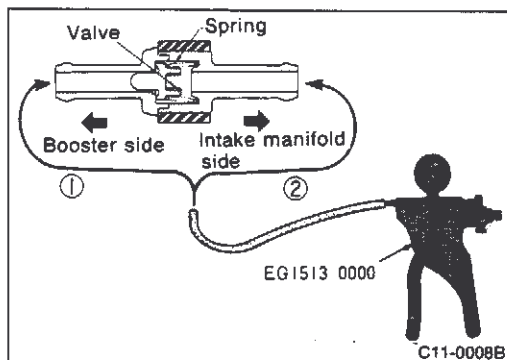

C11-0008B

2-10 REAR CONTROL EQUIPMENT FUNCTION INSPECTION

- Use brake fluid pressure gauge (special service tool) to measure front and rear brake fluid pressure.

CAUTION:

Bleed air after measurement is completed.

- The front and rear brake fluid pressure is set to a 1 : 1 ratio at the split point (S). Check that the rear brake fluid pressure is reduced according to the following specifications.
- D_2 indicates the rear brake pressure hydraulic pressure when the front brake pressure is added to D_1 .

Specifications

	kPa (kg/cm ² , psi)
Engine	RB26DETT
S (split point)	1,765 - 2,550 (18 - 26, 256 - 370)
D_1 (front brake pressure)	5,394 (55, 782)
D_2 (rear brake pressure)	3,138 - 3,923 (32 - 40, 455 - 569)

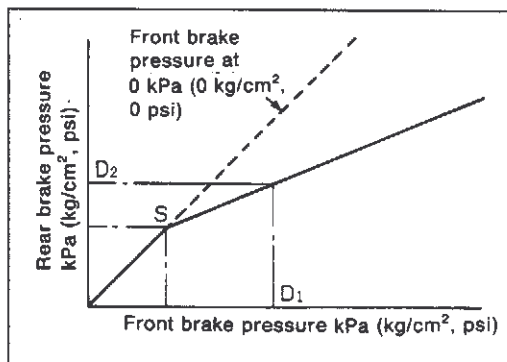

Reference: Rear brake fluid pressure D_2 is determined as follows.

$$D_2 = LP + S$$

$$L \text{ (reducing ratio)} = 0.4$$

$$S \text{ (split point)} = 1,961^{+588}_{-196} \text{ kPa } (20.2^{+6}_{-2} \text{ kg/cm}^2, 284^{+85}_{-26} \text{ psi})$$

$$P \text{ (additional pressure from split point)} = 3,432 \text{ kPa } (35 \text{ kg/cm}^2, 498 \text{ psi})$$

$$D_2 = 0.4 \times 35 + 20.2^{+6}_{-2} = 3,138 - 3,923 \text{ kPa } (32 - 40 \text{ kg/cm}^2, 455 - 569 \text{ psi})$$

C10 BRAKES

2. On-vehicle Inspection (Cont'd)

2-11 DISK PAD THICKNESS INSPECTION

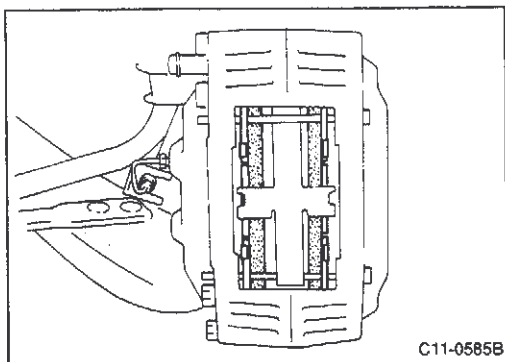

OPZ25VR models

- Check pad thickness at middle hole in cylinder body as shown in figure.

Model	OPZ25VR
Wear limit thickness	2 mm (0.08 in)
Reference: new part thickness	10 mm (0.39 in)

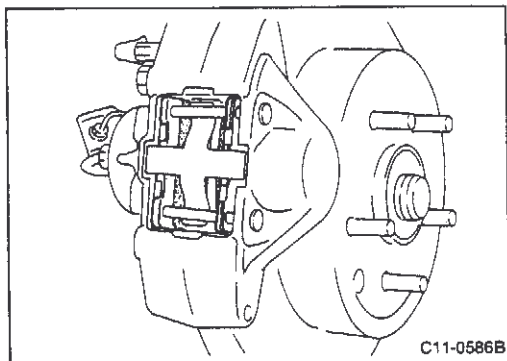

OPZ11VB models

- Check pad thickness at middle hole in cylinder body as shown in figure.

Model	OPZ11VB
Wear limit thickness	2 mm (0.08 in)
Reference: new part thickness	11.5 mm (0.453 in)

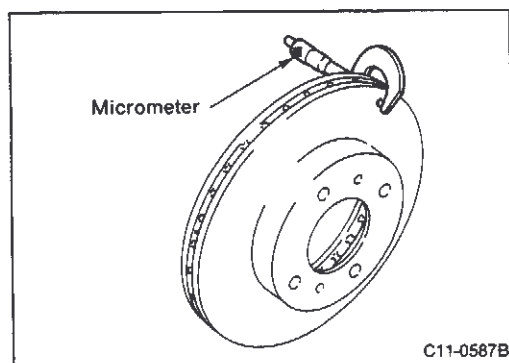

2-12 DISC ROTOR INSPECTION

(1) Disc thickness inspection

- After removing caliper assembly, check following items.
- Check disc rotor for wear or damage.
- Measure disk thickness.

Front

Model	OPZ25VR
Wear limit thickness	30 mm (1.18 in)
Reference: New part thickness	32 mm (1.26 in)

Rear

Model	OPZ11VB
Wear limit thickness	16 mm (0.63 in)
Reference: New part thickness	18 mm (0.71 in)

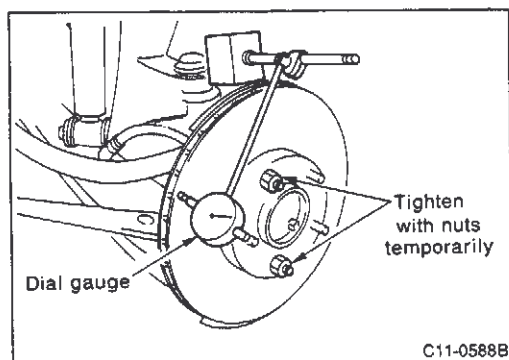

(2) Disk rotor runout inspection

- Make sure that front axial end play is less than 0.03 mm (0.0012 in) before measuring disk surface runout.
- Secure rotor on axle and measure runout.

CAUTION:

Secure rotor to wheel hub with two nuts in criss-cross direction.

Measurement location	Check within 10 mm (0.39 in) from outside edge of rotor.
Runout limit	0.07 mm (0.0028 in)

C10 BRAKES

2. On-vehicle Inspection (Cont'd)

2-13 BRAKE DRUM INSPECTION

Check following items.

- Check for cracks or damage.
- Check for scoring, partial wear or stepped wear inside of drum.
- Measure inside of drum.

Model	DS17HD
Wear limit	173 mm (6.81 in) diameter
Reference: new part inner diameter	172 mm (6.77 in) diameter

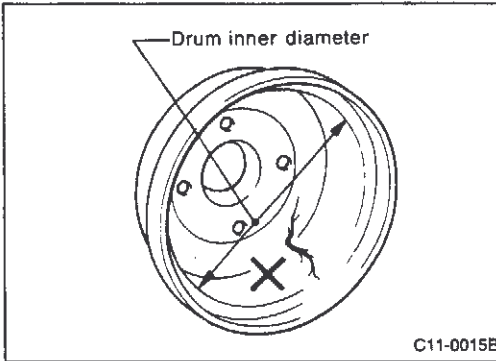

2-14 BRAKE SHOE INSPECTION

Check following items when installing brake drum.

- Check lining for abnormal wear, damage or separation.
- Check that assembly for loose conditions.
- Measure lining thickness.

Model	DS17HD
Wear thickness limit	1.5 mm (0.059 in)
Reference: New part thickness	3.0 mm (0.118 in)

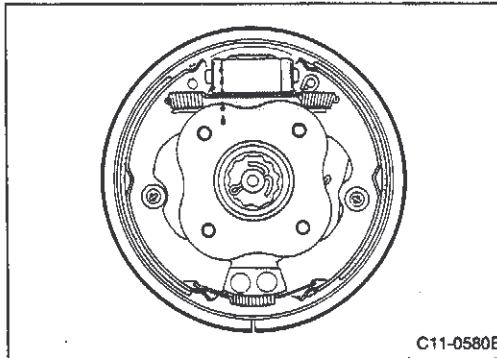

- Check wheel cylinder for leakage.

2-15 PARKING BRAKE INSPECTION AND ADJUSTMENT

Check and adjust following items.

- Make sure that parking brake lever operates smoothly.
- Check rods and cables for cracks, wear, deformation and rust.
- Check clamps and connections for looseness.
- Check that brake warning lamp lights within one notch.
- The catch operates within a specified number of notches when an operating force of 196 N (20 kg, 44 lb) is applied. Adjust rear shoe clearance if brake does not engage with specified number of notches. Adjust cable so brake engages at specified number of notches.

Specified number of notches:

6 - 8 notches

CAUTION:

If the cable and notch adjustment is made without adjusting shoe clearance, the rear brake may not engage.

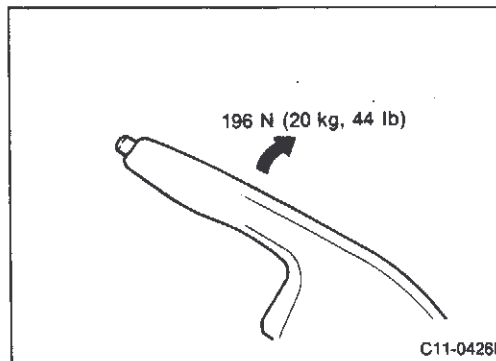

C10 BRAKES

2. On-vehicle Inspection (Cont'd)

(1) Shoe clearance adjustment

Return lever completely. When cable is adequately loose (Refer to (2) Cable adjustment), adjust rear shoe clearance.

Model DS17HD

- Install wheel.
- Use suitable nuts (M12 x 1.25) so disk is installed securely as shown in figure and attach disk rotor to hub.
- Remove disc adjustment hole plug from disc. Use screwdriver and turn adjuster in direction **A** shown in figure until disc locks. After disc locks turn adjuster five or six notches in opposite direction.
- Turn rotor and make sure brakes do not engage. Install stroke adjustment hole plug.

CAUTION:

After adjusting shoe clearance, always adjust lever by cable so brake engages at specified number of notches.

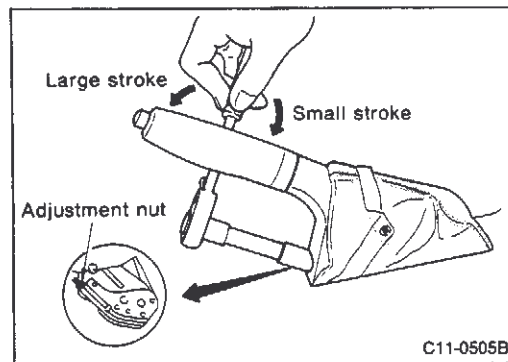
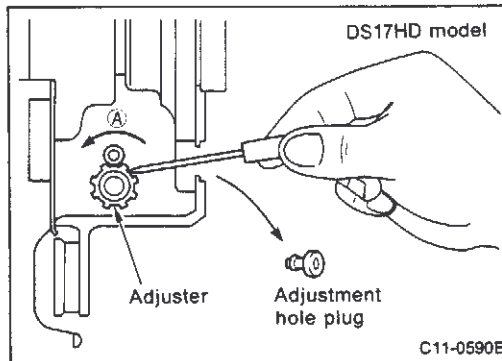
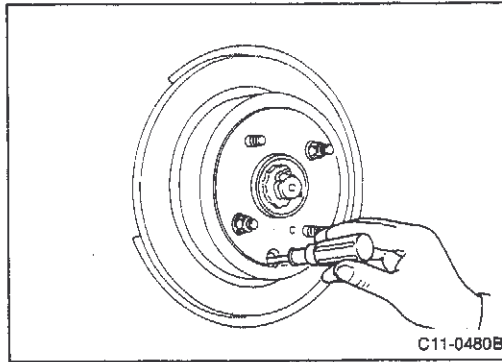

(2) Cable adjustment

After adjusting rear shoe clearance, adjust cable when rear brake is not engaged.

- Raise lever 4 - 5 notches.
- Insert ratchet wrench (use taped socket) in lever opening and turn self-locking adjustment nut to adjust lever stroke.
- Operate lever 3 - 4 times and adjust stroke so lever engages within specified number of notches.
- Return lever completely and make sure there is no drag between shoes and brake drum when rotating disc rotor.

(3) Breaking-in parking brake DS17HD model shoes

Perform following procedures if braking is inadequate after replacing DS17HD parking brake, shoes and disc rotor.

Operation

- ① Adjust parking brake control lever to specified number of notches.
[Refer to (1) Shoe clearance adjustment and (2) Cable adjustment.]
- ② Break-in parking brake by driving vehicle as follows.
 - Drive forward at approximately 35 km/h (22 MPH).
 - Depress parking brake pedal with a force of approx. 88 N (9 kg, 20 lb).
 - While depressing the pedal, continue to drive the vehicle forward 100 m (328 ft).
 - Repeat this procedure three more times. [Total distance is approximately 300 m (984 ft).]
- ③ Perform parking brake stroke inspection. Adjust if brake engagement has changed from specified number of notches.

C10 BRAKES

2. On-vehicle Inspection (Cont'd)

CAUTION:

- (1) Perform break-in operation in a location with good visibility and at a distance from other vehicles.**
- (2) Allow unit to cool off 5 min after each break-in procedure to prevent linings from overheating.**
- (3) Do not perform the break-in procedure too many times because it may cause uneven or premature wear.**

3. Trouble Diagnosis (Anti-Lock Braking System)

3-1 TROUBLESHOOTING

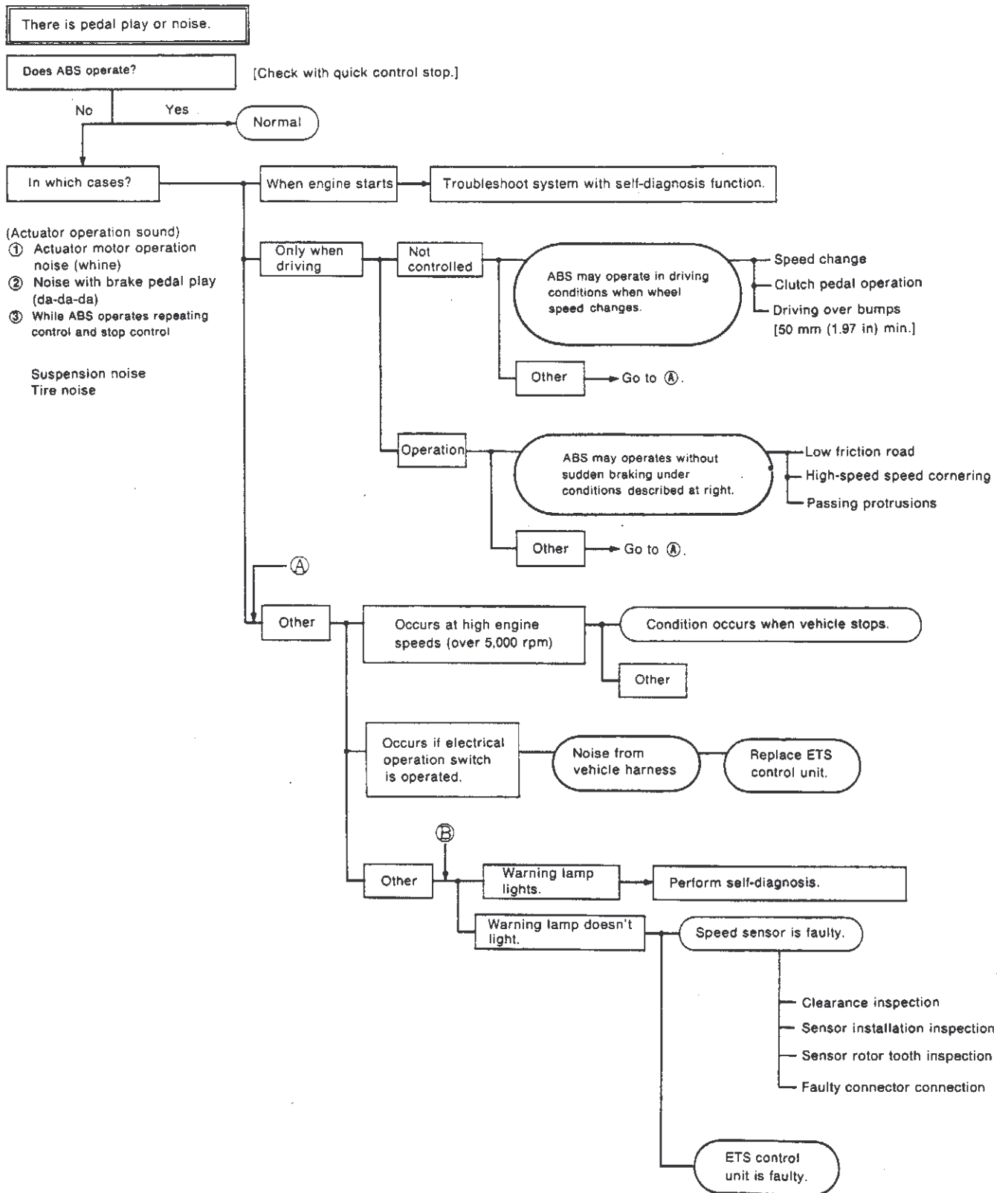

C10 BRAKES

3. Trouble Diagnosis (Anti-Lock Braking System) (Cont'd)

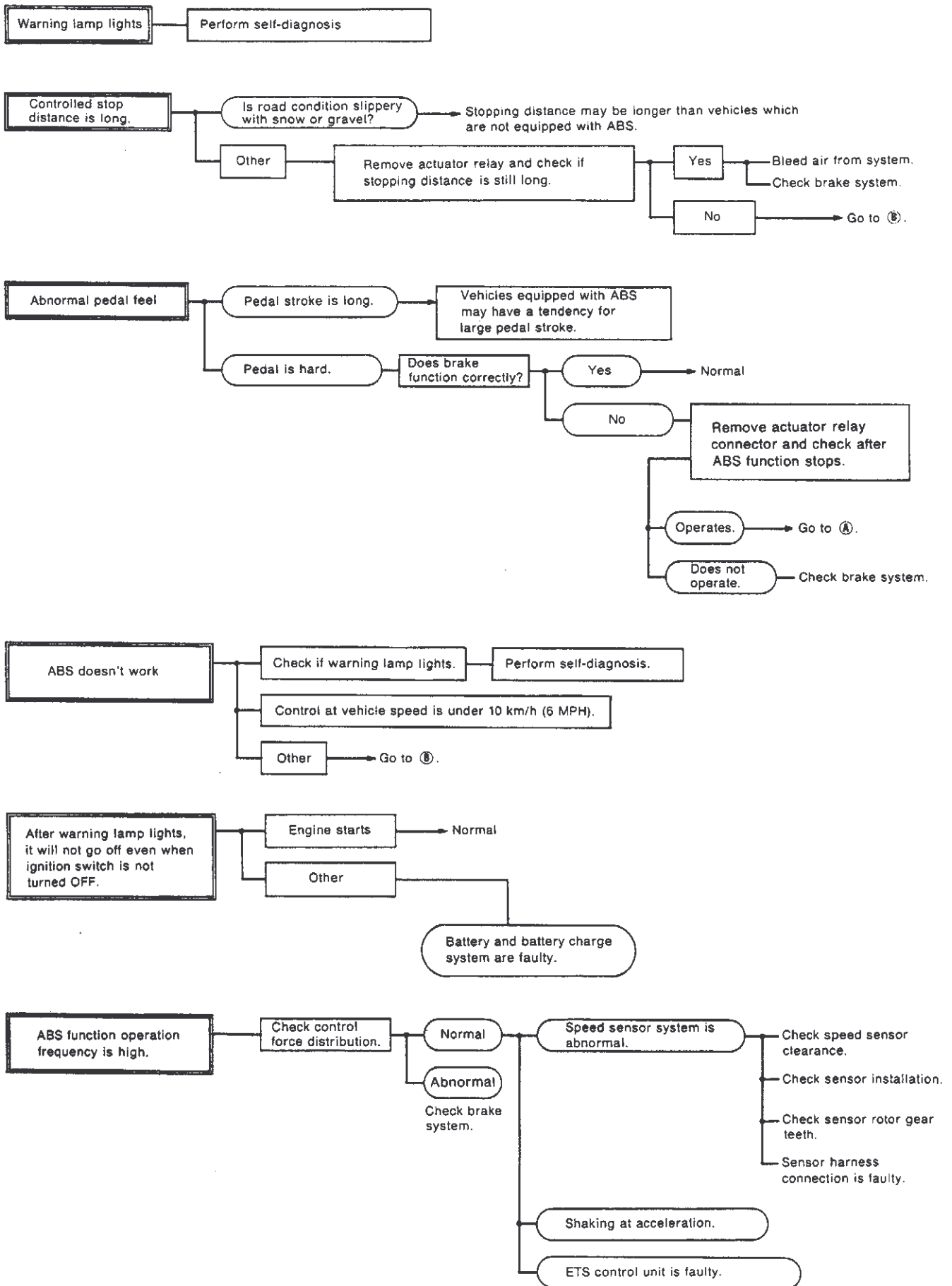

C10 BRAKES

3. Trouble Diagnosis (Anti-Lock Braking System) (Cont'd)

3-2 INSPECTION PREPARATION

(1) Circuit diagram

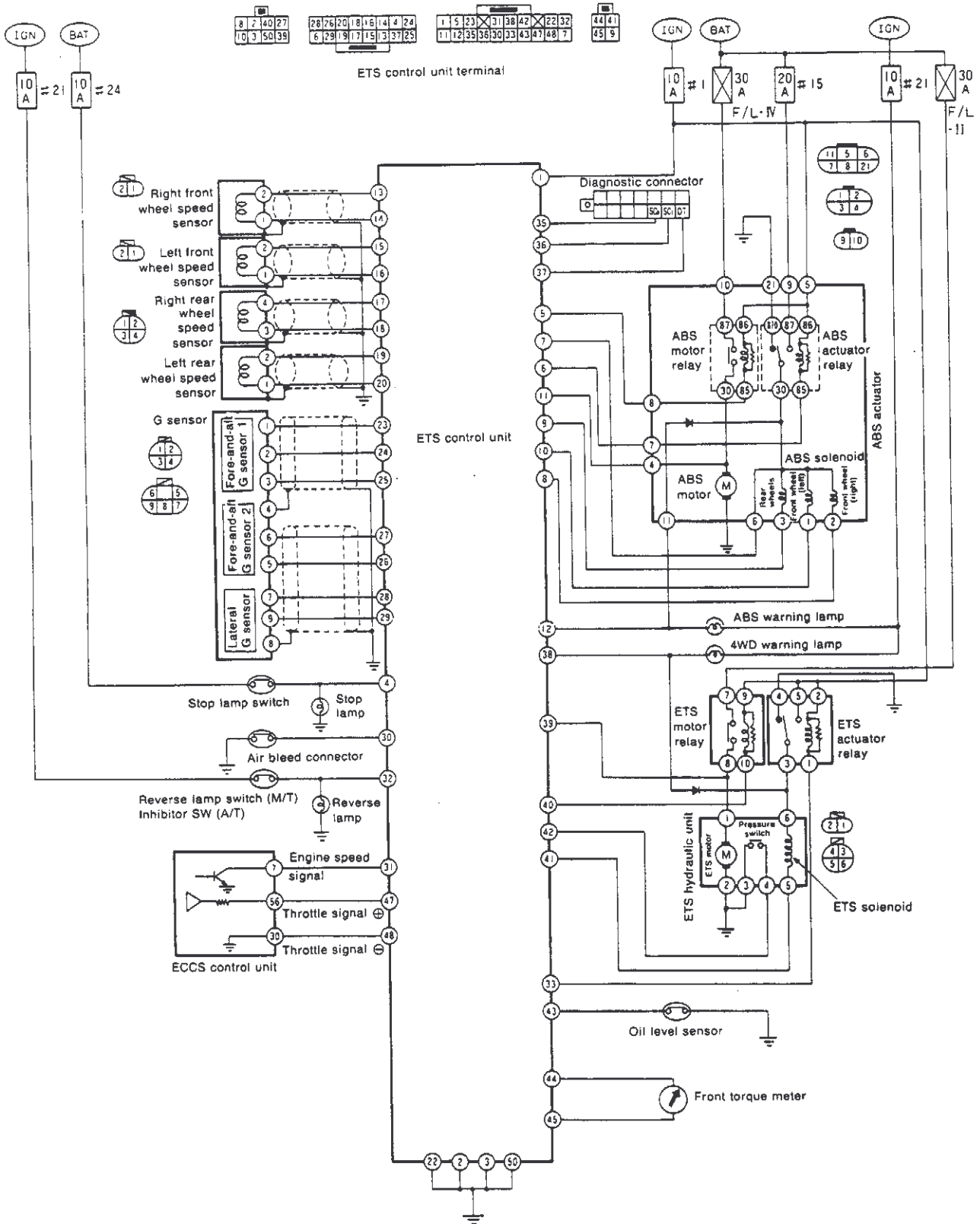

C10 BRAKES

3. Trouble Diagnosis (Anti-Lock Braking System) (Cont'd)

(2) Trouble diagnosis by self-diagnosis

① When CONSULT is not used



② Self-diagnosis description

- If ABS is normal, the ABS warning lamp lights when ignition switch is ON and goes off within one second after engine starts. When the warning lamp does not go out, abnormal conditions are indicated by the number of times the LED flashes in the ETS control unit below the rear parcel shelf.
- Warning lamp lights or LED flashes to indicate connection condition after damage repair when ignition switch is not turned OFF. Be sure to turn ignition switch OFF one time after repair for this reason and then perform self-diagnosis again. If two or more systems malfunction, all faulty systems are displayed sequentially and displayed by number of LED flashes.

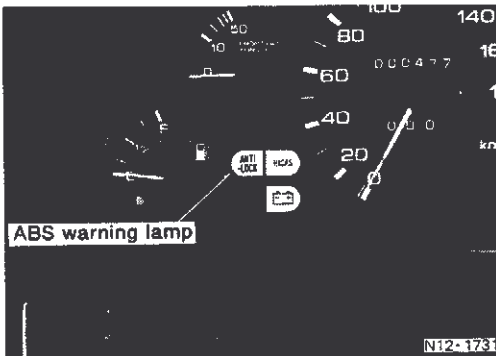

Example 1: One system malfunctions.

- Front right speed sensor or circuit is damaged.

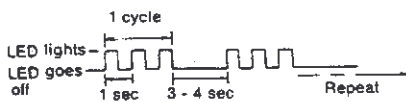

Example 2: Two or more systems malfunction.

- Front left wheel speed sensor or circuit and left rear wheel speed sensor or circuit malfunction.



C11-0591B

C10 BRAKES

3. Trouble Diagnosis (Anti-Lock Braking System) (Cont'd)

Problems are classified by the following code numbers.

Number of LED flashes	Malfunction location	Detection cycle		Warning lamp		Flow chart (Note 3)
		Engine starts	During driving	ABS	ETS	
1	Front right wheel speed sensor circuit	○ (Note 1)	○	○	○	*
2	Front left wheel speed sensor circuit	○ (Note 1)	○	○	○	*
3	Rear right wheel speed sensor circuit	○ (Note 1)	○	○	○	*
4	Rear left wheel speed sensor circuit	○ (Note 1)	○	○	○	*
5	ABS front right side actuator solenoid valve circuit	○	○	○		A
6	ABS front left side actuator solenoid valve circuit	○	○	○		B
7	ABS rear actuator solenoid valve circuit	○	○	○		C
8	ABS actuator motor and motor relay circuit	○	○	○		D
9	ABS actuator relay and circuit	○	○	○		E
10	ETS control unit power supply circuit	○	○	○		F
11	Fore-and-aft G sensor 1 circuit	○	○	○	○	*
12	Fore-and-aft G sensor 2 circuit	○	○	○	○	*
13	Fore-and-aft rear G sensor 1 and G sensor 2 circuit	○	○	○	○	*
14	G sensor power supply 1 circuit	○	○	○	○	*
15	G sensor power supply 2 circuit	○	○	○	○	*
16	Lateral G sensor circuit	○	○	○	○	*
17	Air bleeding connector circuit		○		○ (Note 2)	—
18	ETS pressure switch circuit	○	○		○	—
19	ETS motor, motor relay circuit	○	○		○	—
20	ETS solenoid circuit	○	○		○	—
21	Throttle sensor circuit	○	○		○	—
22	ETS reservoir tank oil level sensor circuit	○	○		○	—
23	—	—	—		—	—
24 Or stays ON or stays OFF	ETS control unit, ground circuit	○	○	○	○	*

Note: 1) Detection may not be possible if there is sensor short-circuit malfunction.

2) During driving, 4WD warning lamp lights during normal control.

3) Refer to C3 Electrical control torque split 4WD system, 3. Troubleshooting for items marked *.

C10 BRAKES

3. Trouble Diagnosis (Anti-Lock Braking System) (Cont'd)

(3) Diagnostic procedure

- ① ABS warning lamp does not light when ignition switch is in ON position (before engine starts).

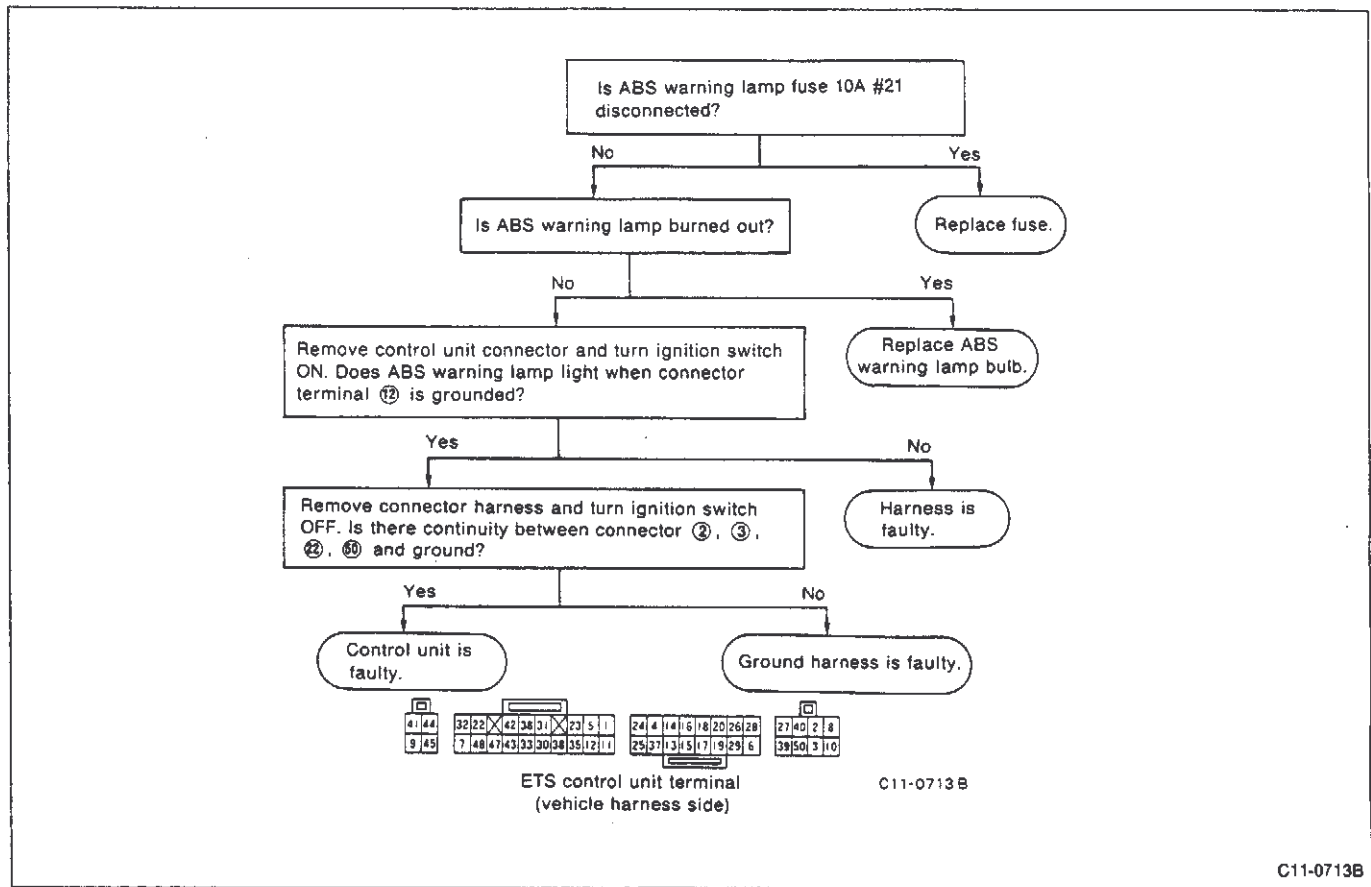

② Malfunction indicated by self-diagnosis

- A. Front right actuator solenoid valve circuit malfunction (LED flashes 5 times)
- B. Front left actuator solenoid valve circuit malfunction (LED flashes 6 times)
- C. Rear actuator solenoid valve circuit malfunction (LED flashes 7 times)

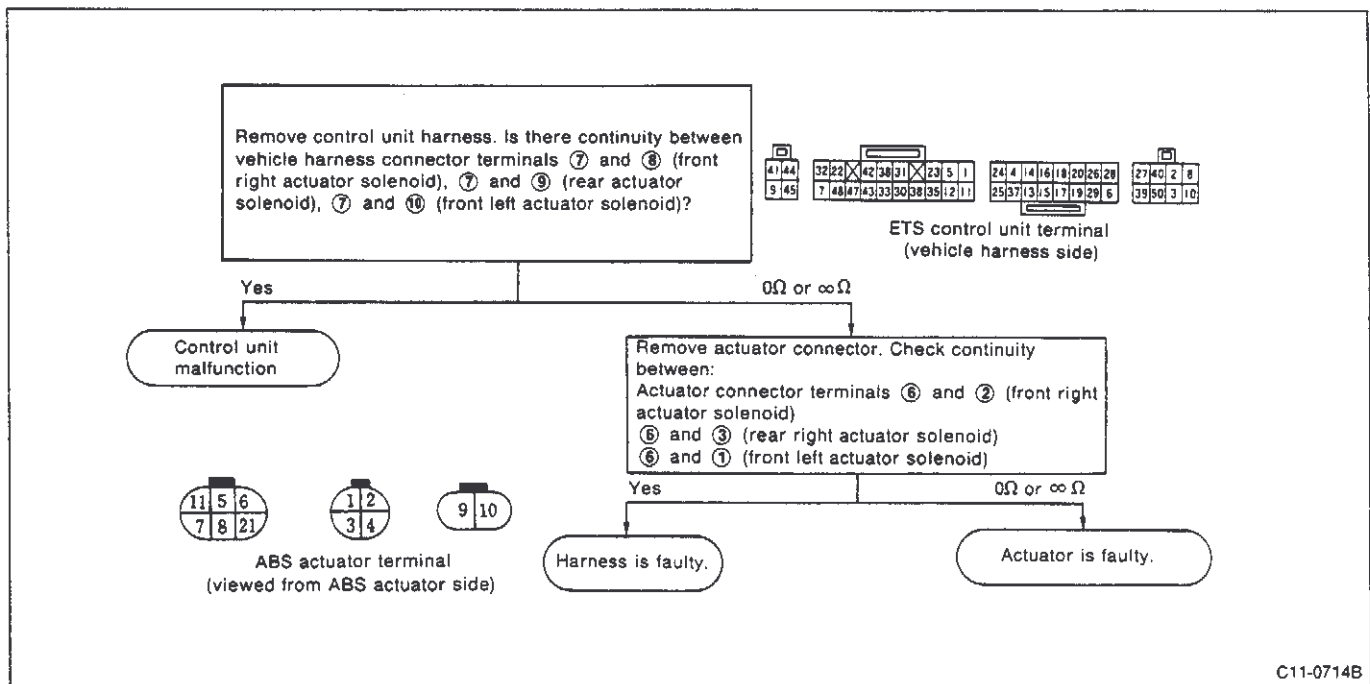

C10 BRAKES

3. Trouble Diagnosis (Anti-Lock Braking System) (Cont'd)

D. ABS motor, motor relay and circuit malfunction (LED flashes 8 times)

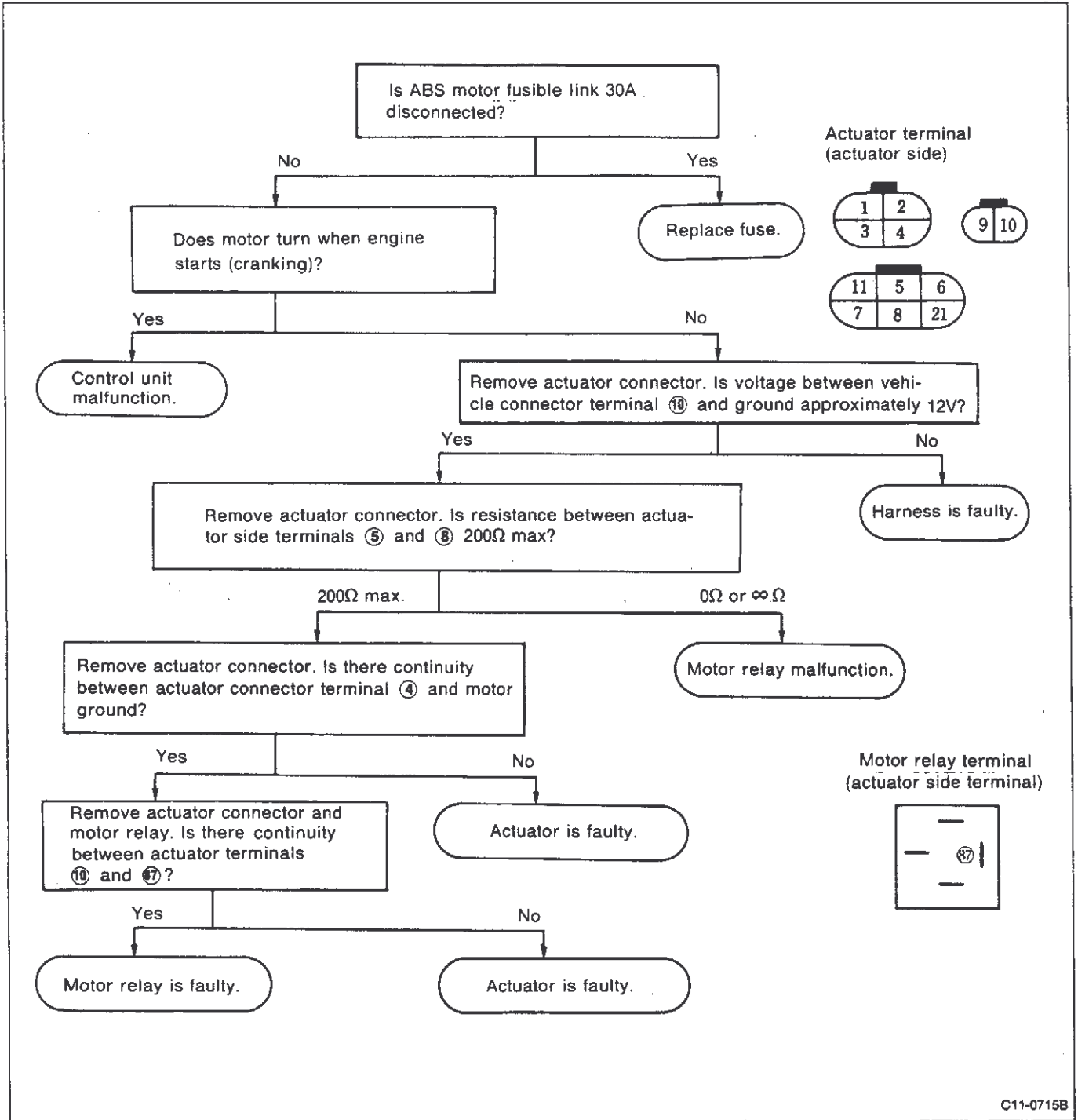

C11-0715B

C10 BRAKES

3. Trouble Diagnosis (Anti-Lock Braking System) (Cont'd)

E. Actuator relay circuit malfunction (LED flashes 9 times)

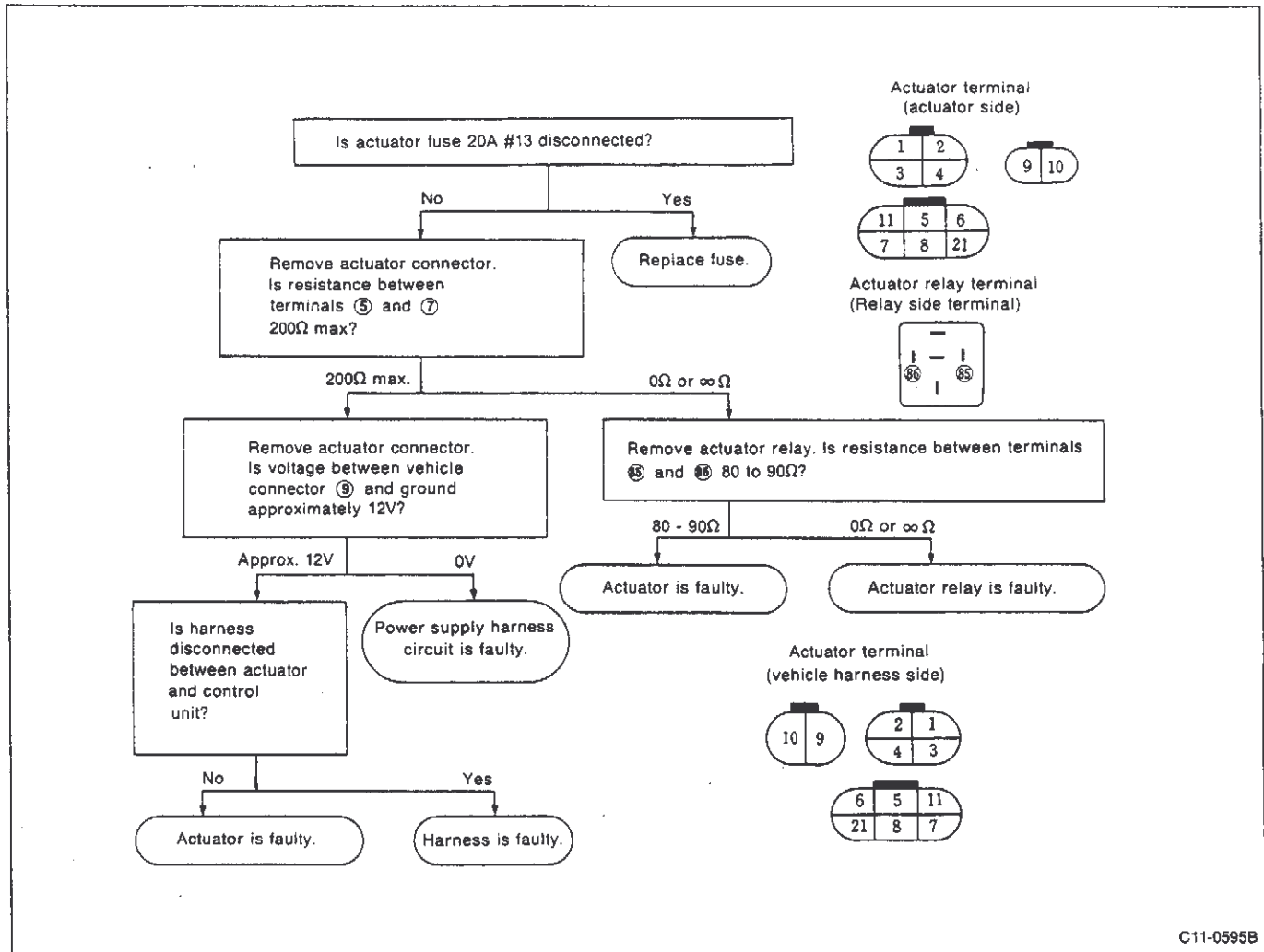

F. ETS control unit power supply circuit malfunction (LED flashes 10 times)

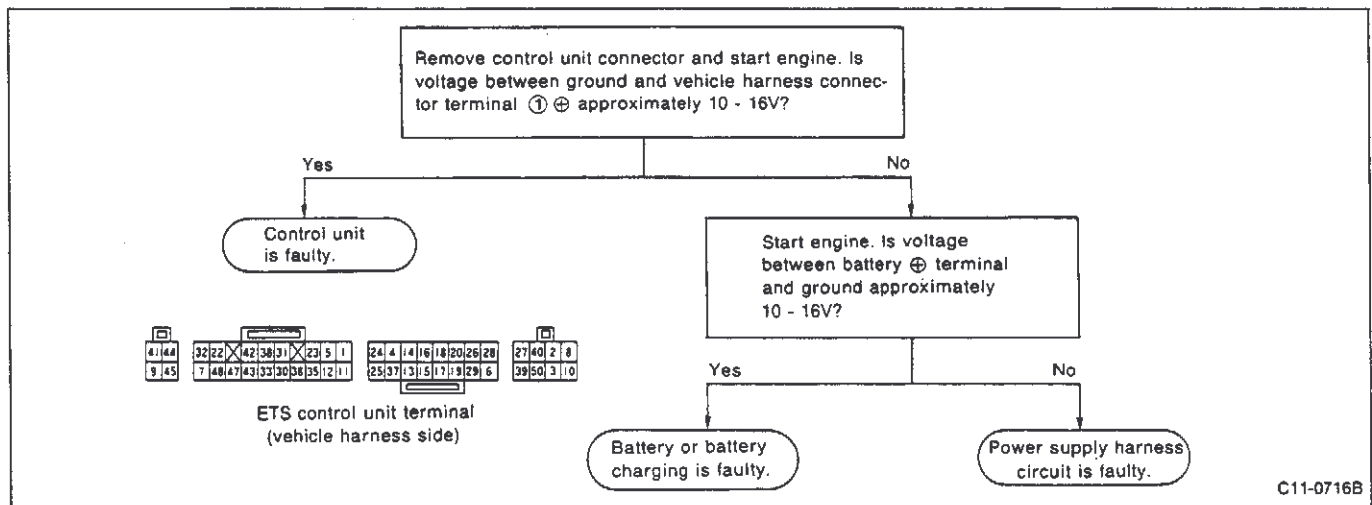

C10 BRAKES

3. Trouble Diagnosis (Anti-Lock Braking System) (Cont'd)

3-3 DAMAGE INSPECTION

- For items ①, ② and ③, refer to "C3 ELECTRICAL CONTROL TORQUE SPLIT 4WD SYSTEM, 3-3 DAMAGE INSPECTION".
 - ① Check speed sensor installation.
 - ② Check speed sensor clearance.
 - ③ Check sensor rotor or G sensor.
- Refer to "C3 ELECTRICAL CONTROL TORQUE SPLIT 4WD SYSTEM, 3-3 DAMAGE INSPECTION"
- ④ Check front suspension and axle (wheel hub play).
 - Check that there is no wheel hub play. If there is hub play, refer to "C7 FRONT SUSPENSION AND AXLE, 2-1 FRONT SUSPENSION AND AXLE INSPECTION".
- ⑤ Rear suspension and axle inspection
 - Check that there is no wheel hub play. If there is hub play, refer to "C8 REAR SUSPENSION AND AXLE, 2-1 REAR SUSPENSION AND AXLE INSPECTION".

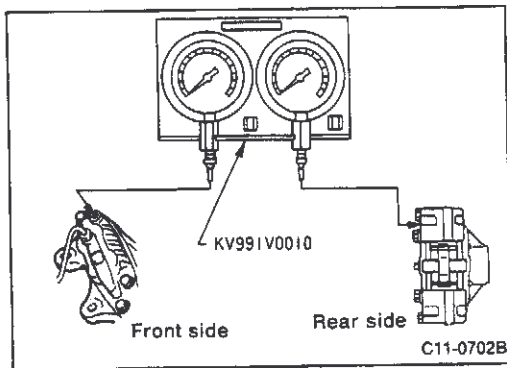

- ⑥ **Control split inspection**
 - Use brake fluid pressure gauge (special service tool) as shown in figure and measure front brake and rear brake pressure.
 - Refer to 2-2 CHECKING BRAKE SYSTEM. The inspection procedures are the same.
- ⑦ **Brake system inspection**
 - Check that the brake system is not leaking or clogged. Replace parts as necessary.
- ⑧ **Air bleeding**
 - Refer to 2-3 CHANGING BRAKE FLUID AND AIR BLEEDING.

C10 BRAKES

3. Trouble Diagnosis (Anti-Lock Braking System) (Cont'd)

3-4 COMPONENT PARTS LOCATION

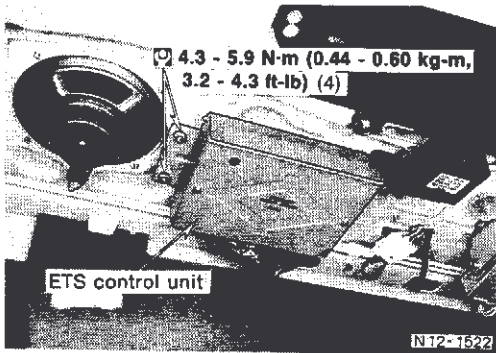

ETS control unit

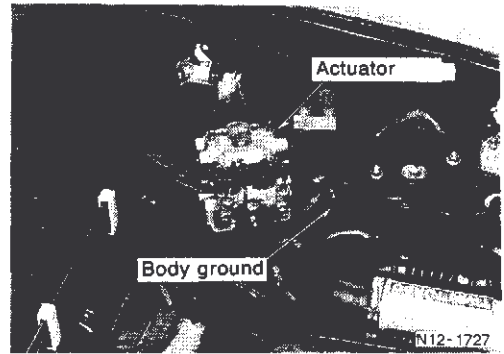

Actuator

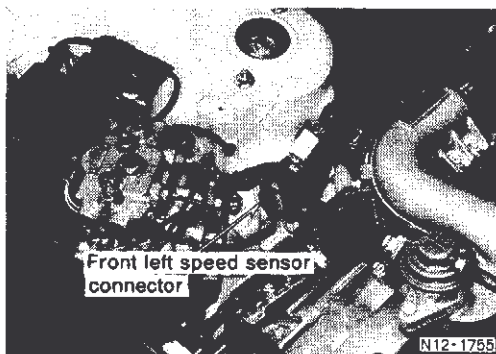

Front left speed sensor

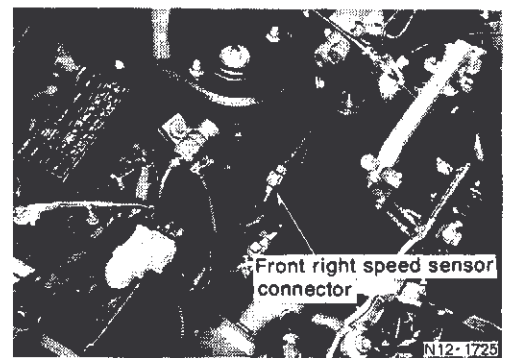

Front right speed sensor

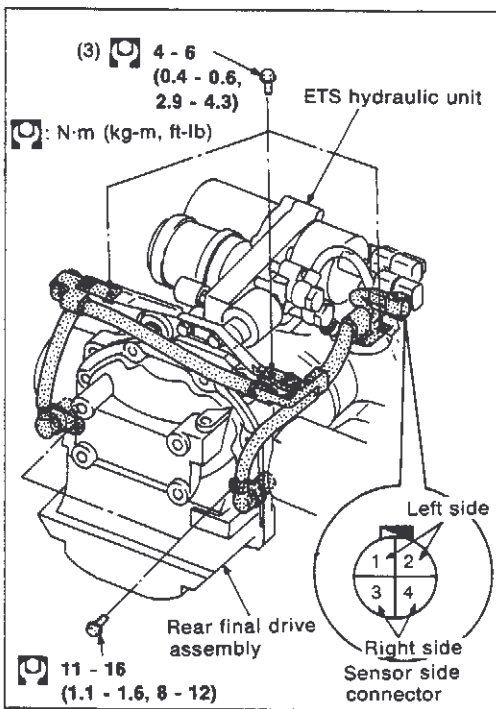

Rear speed sensor

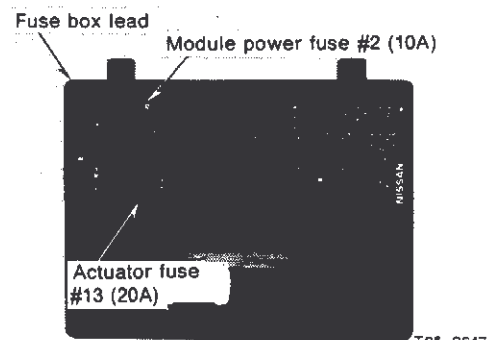

ABS fuses



ABS fusible link

C10 BRAKES

4. Removal and Installation, Assembly and Disassembly

4-1 BRAKE PIPING

Vehicles equipped with ABS

- Remove brake fluid before removal and installation.
- After removal and installation always bleed air from system.
- Brake hose installation [Point 2]
- Flare nut 15 - 18 N-m (1.5 - 1.8 kg-m, 11 - 13 ft-lb) [Point 1]
- Union bolt 17 - 20 N-m (1.7 - 2.0 kg-m, 12 - 14 ft-lb)
- Connector 17 - 20 N-m (1.7 - 2.0 kg-m, 12 - 14 ft-lb)

— : Brake tube
= : Brake hose

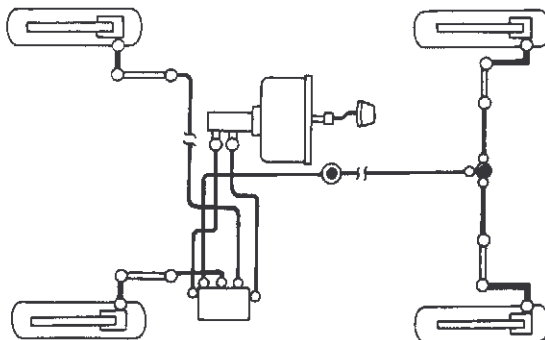

OPZ25VR models

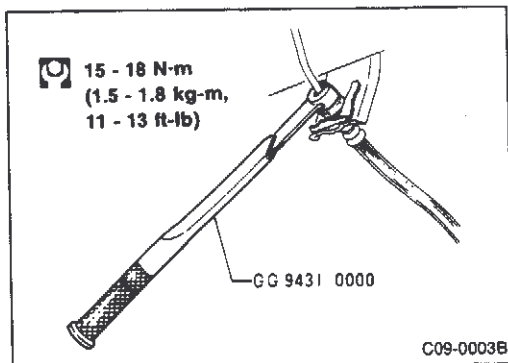

[Point 1] Flare nut removal and installation

- Use a flare nut wrench to remove flare nuts. Use a flare nut torque wrench (special service tool) to tighten flare nuts. Be careful not to scratch or damage brake pipes or flare nuts.

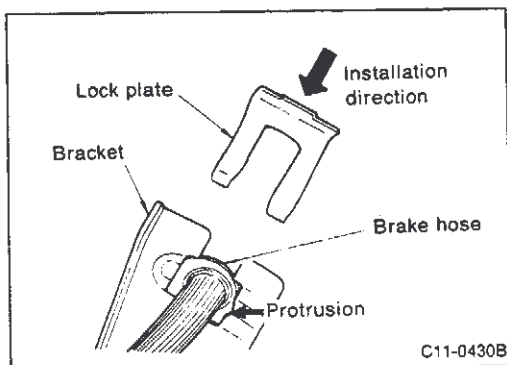

[Point 2] Brake hose installation

- The left and right front brake hoses are the same for all models.
- Assemble hose from cylinder body. Align lock plate direction as shown in figure and secure.

CAUTION:

- (1) Align protrusions on each hose with the hose bracket.
- (2) After installation check that hose is not twisted or bent and does not interfere with other parts.

C10 BRAKES

4. Removal and Installation, Assembly and Disassembly (Cont'd)

4-2 BRAKE PEDAL BRACKET REMOVAL AND INSTALLATION, ASSEMBLY AND DISASSEMBLY

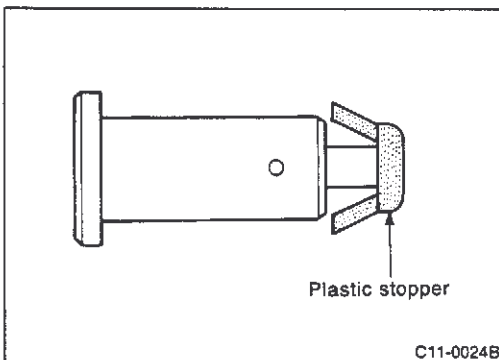
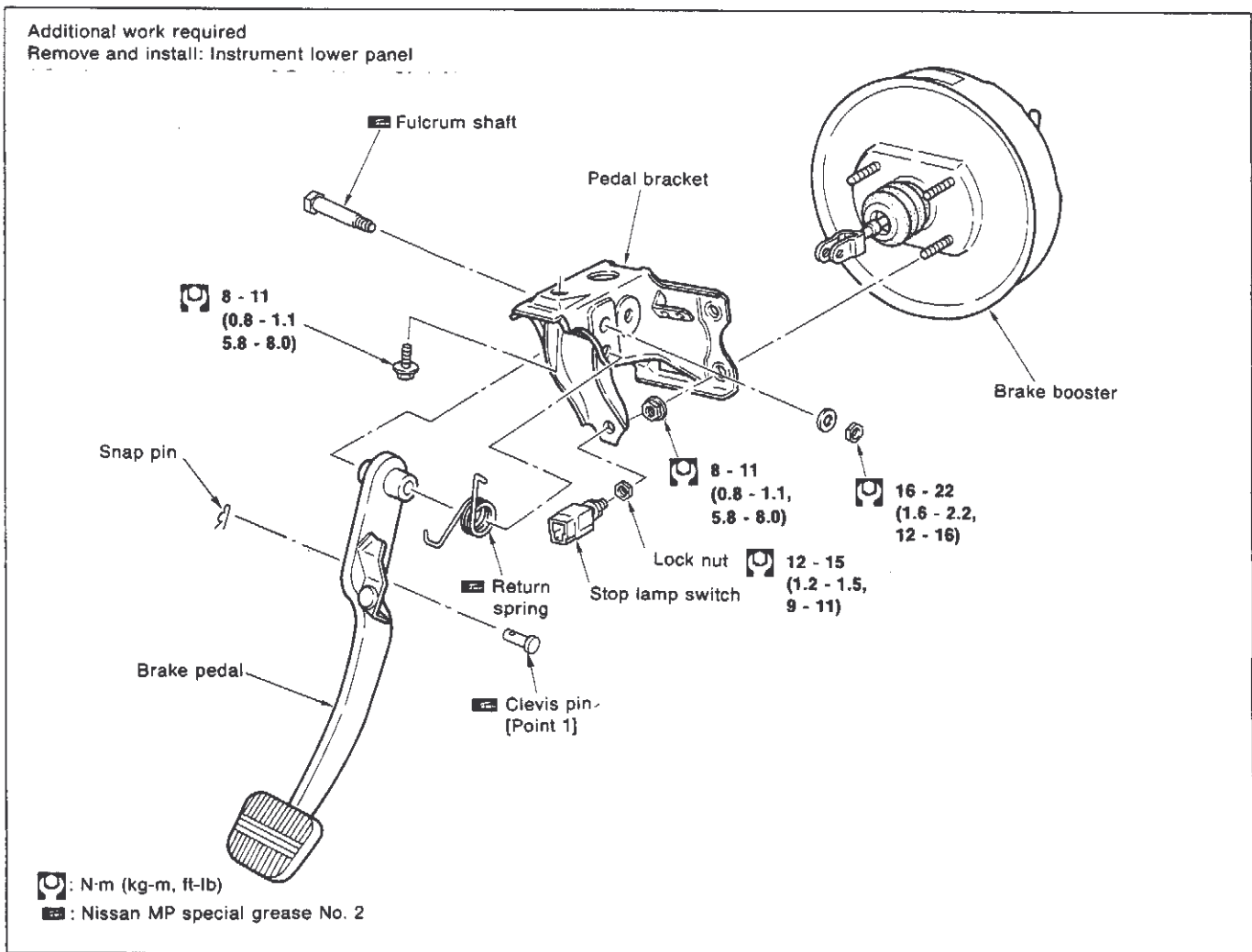

[Point 1] Clevis pin removal and installation

- Check that plastic stopper on end of clevis pin is not damaged or deformed. Replace if necessary.
- Insert clevis pin from right side as shown in figure. Install securely with snap pin.

C10 BRAKES

4. Removal and Installation, Assembly and Disassembly (Cont'd)

4-3 VACUUM PIPE REMOVAL AND INSTALLATION (vehicles equipped with RB26DETT engine)

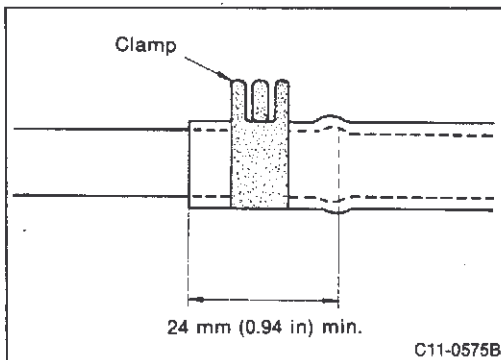
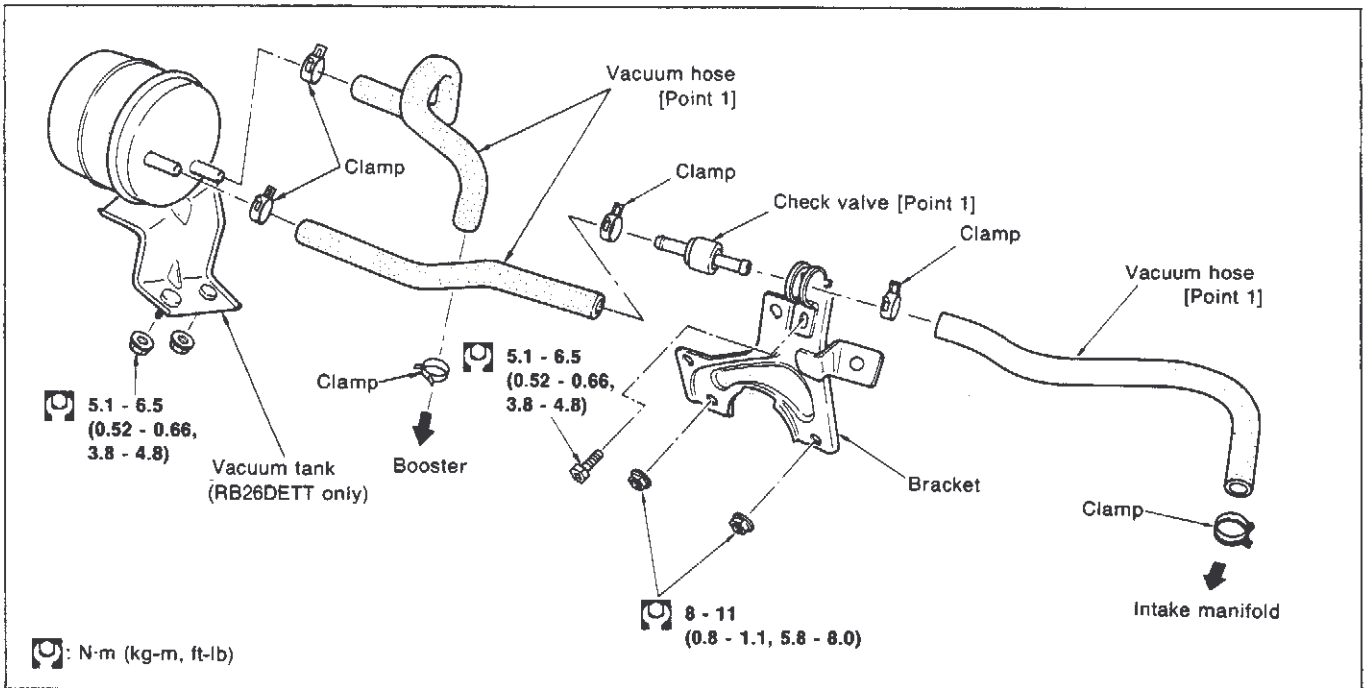

[Point 1] Vacuum hose installation

- Insert hose at least 24 mm (0.94 in).
- Do not use lubrication oil to install hose.

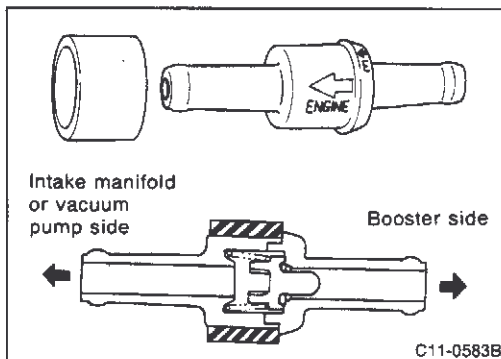

[Point 2] Check valve installation

- Assemble check valve with arrow mark facing engine side (intake manifold side).

C10 BRAKES

4. Removal and Installation, Assembly and Disassembly (Cont'd)

4-4 MASTER CYLINDER AND BOOSTER

(1) Removal and installation

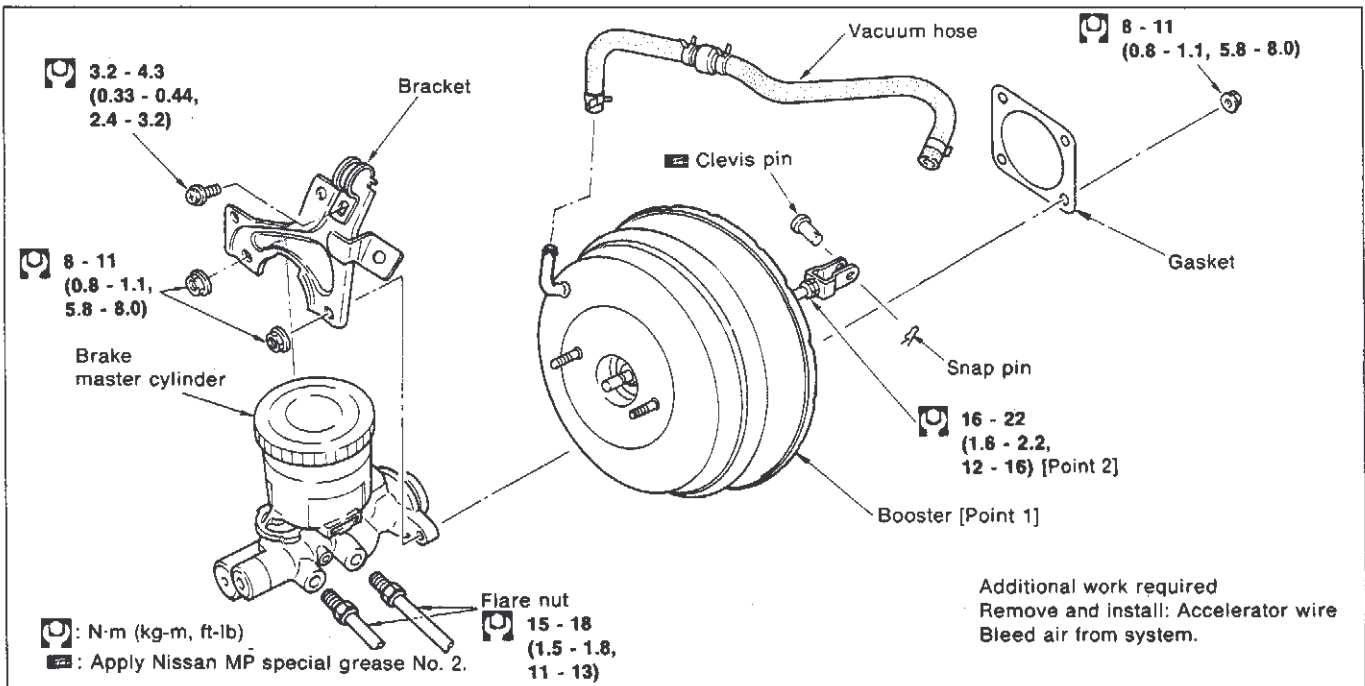

[Point 1] Booster removal and installation

Removal

- Separate master cylinder and brake tube.
- Remove snap pin and clevis pin.
- Remove pedal bracket and nuts (4) and remove from engine compartment.

Installation

- Assembly is the reverse of disassembly.
- After installing booster, temporarily tighten master cylinder. Install brake tubes and then tighten master cylinder bolts to specified torque.

CAUTION:

Be careful not to scratch reservoir tank or body during removal and installation.

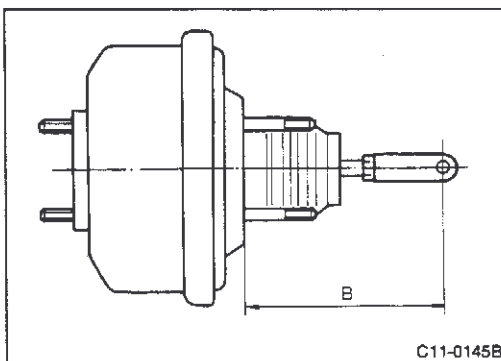

[Point 2] Operating rod standard dimension adjustment

- Loosen lock nut and adjust operating rod so dimension B is standard length.
B dimension specification length:
142 - 149 mm (5.59 - 5.87 in)
- After adjustment, temporarily tighten lock nut. After installation in vehicle, adjust pedal height and play. Tighten lock nut to specified torque.

C10 BRAKES

4. Removal and Installation, Assembly and Disassembly (Cont'd)

(2) Master cylinder assembly and disassembly

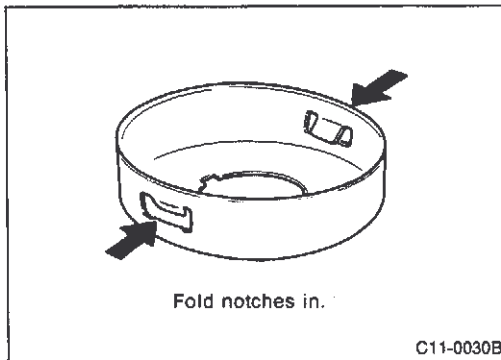
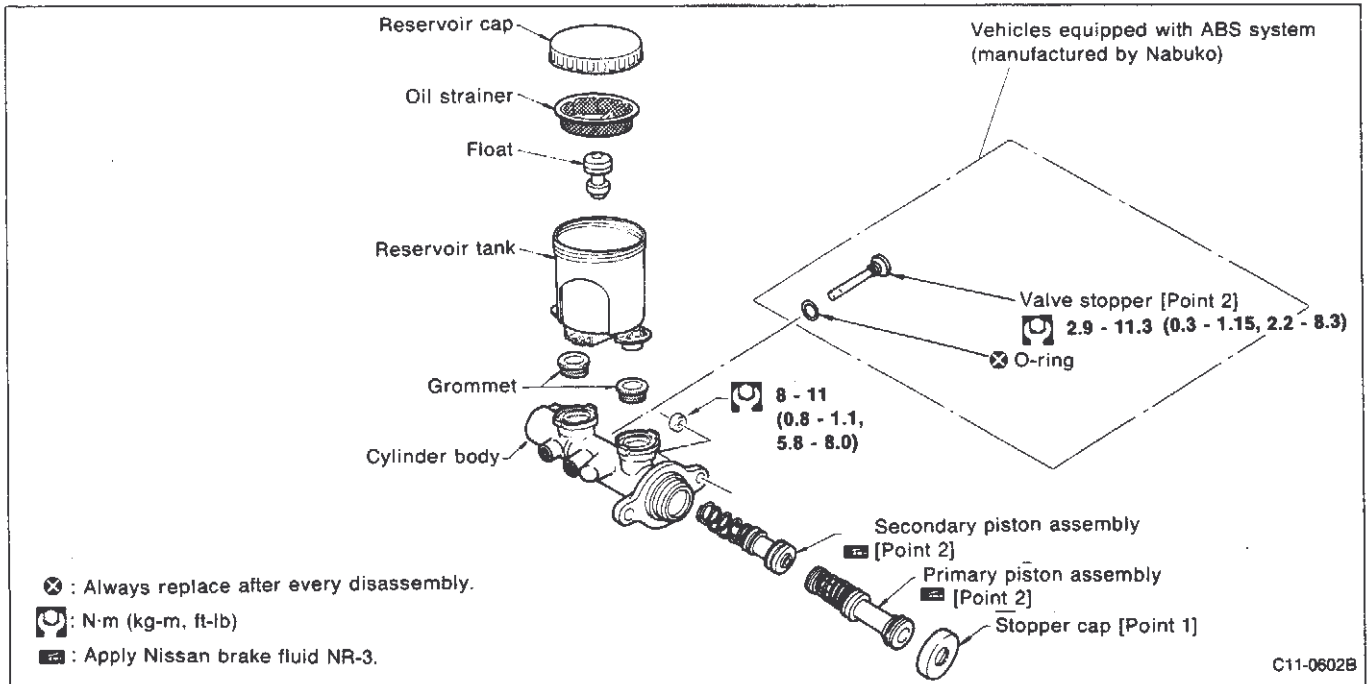

[Point 1] Stopper cap installation

- If notches are bent or deformed replace stopper cap.
- Fold notches in and insert cap.

C10 BRAKES

4. Removal and Installation, Assembly and Disassembly (Cont'd)

[Point 2] Inner kit assembly installation

- Always replace assembly with inner kit.
- Check cup direction and install.
- While pressing primary piston with Phillips screwdriver, install valve stopper.

CAUTION:

Do not wash with mineral oil because it may deform or damage rubber parts.

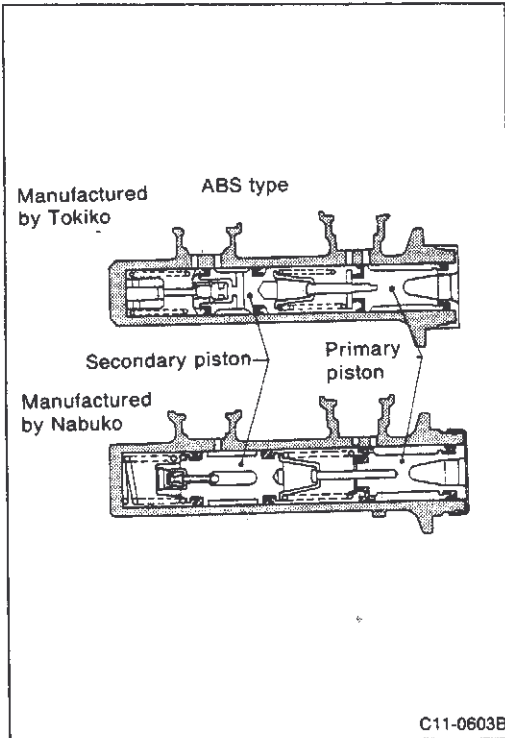

C11-0603B

C10 BRAKES

4. Removal and Installation, Assembly and Disassembly (Cont'd)

4-5 FRONT BRAKE

(1) Caliper assembly removal and installation, assembly and disassembly (OPZ25VR model)

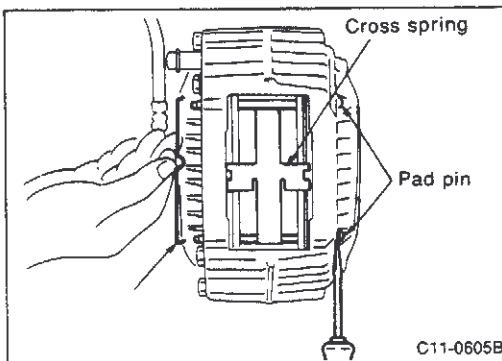
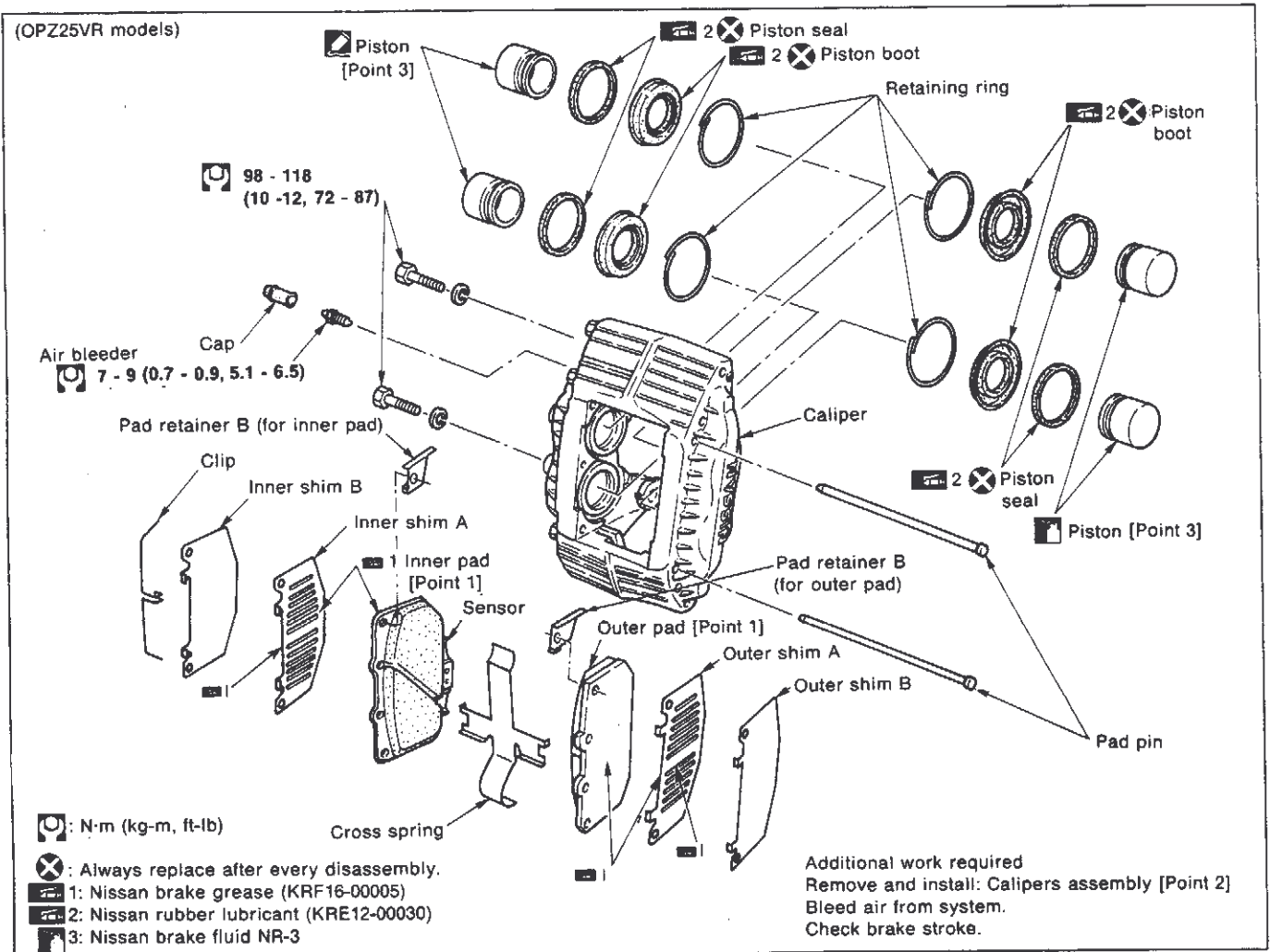

[Point 1] Pad removal and installation

Removal

- Remove clip from pad pins.
- While pressing cross spring, remove pad pins.

CAUTION:

Check pad pins and clips for fatigue, deformation, damage and rust. Replace with new parts if necessary.

C10 BRAKES

4. Removal and Installation, Assembly and Disassembly (Cont'd)

- Use pliers to remove pads when attached to shims.

CAUTION:

Check calipers and piston boot for damage, rust and deformation. Replace parts as necessary.

- Remove shim and pad retainer from pads.

CAUTION:

If the shim or shim cover are rusted or rubber coat is peeled, replace with new part.

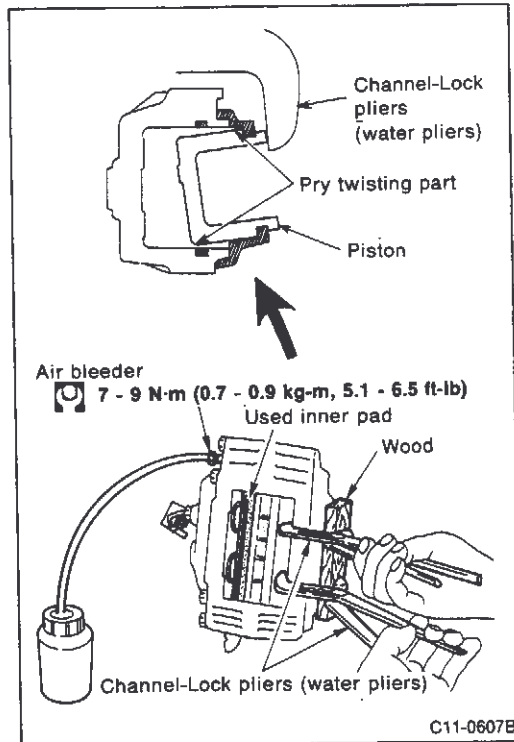
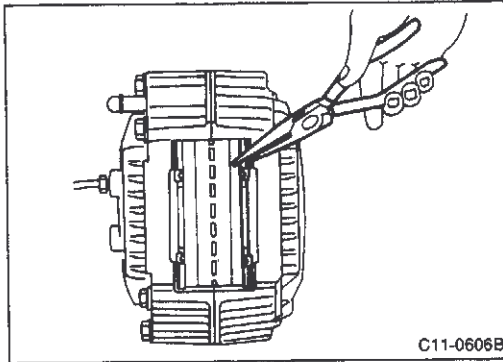

Pad replacement

- If pad thickness does not exceed wear limit indicated below, compress inner and outer pistons to install new pads.

Inspection specifications

Model	OPZ25VR	
Wear limit	mm (in)	2 (0.08)
(Reference) New pad thickness	mm (in)	11.5 (0.453)

- Install old inner pad as shown in figure to prevent piston from popping out.
- Release air bleeder and use pliers to compress two outer pistons simultaneously. Place wood on outside to prevent scratching calipers.

CAUTION:

- (1) Connect vinyl tube to air bleeder and be careful not to get brake fluid on body.
- (2) When pressing piston into calipers, change pressure position of outer pliers so piston does not jam in cylinder.
- (3) Temporarily tighten wheel nuts so disc does not incline.

- Remove old inner pad and install new outer pad as shown in figure so outside piston does not pop out.
- Place wood on outer side as described above. Use pliers to compress two inner pistons simultaneously.
- Tighten air bleeder.
- Remove new outer pad to compress inner and outer pistons and complete operation.

CAUTION:

- (1) After replacing brake pads, bleed air from system.
- (2) Replace pads as a set on both left and right wheels at the same time.

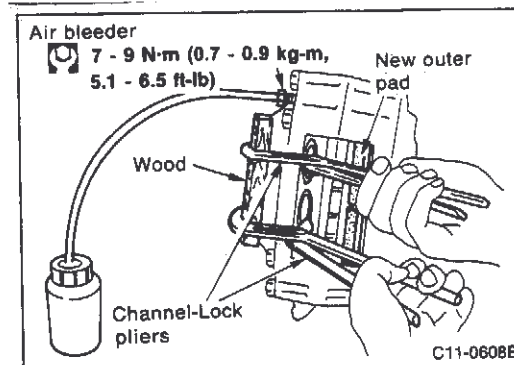

Installation

- Apply a uniform coat of Nissan brake grease [approx. 0.7 to 10 g (0.025 to 0.353 oz)] to rear metal surface of inner and outer pads and to both sides of shim A.

CAUTION:

- (1) Wipe off excess brake grease so it does not adhere to pad friction surface or caliper installation surface.
- (2) Install shims A and B in sequence shown in figure.

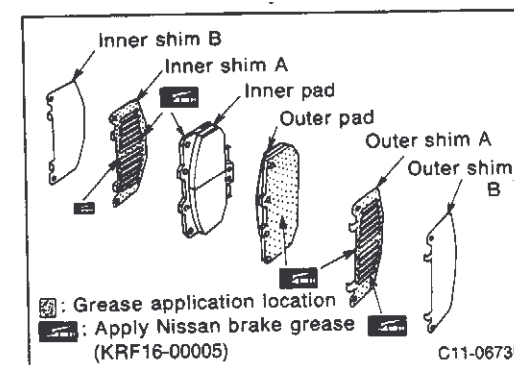

C10 BRAKES

4. Removal and Installation, Assembly and Disassembly (Cont'd)

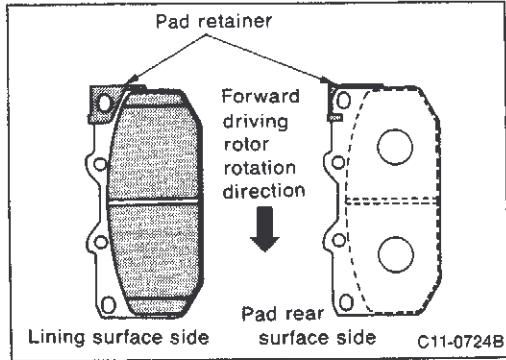

- Assemble inner and outer pad so pad retainer faces opposite side of forward driving disc rotation direction (upper side of installed calipers).

CAUTION:

Omission or incorrect assembly of pad retainer may cause abnormal brake noise.

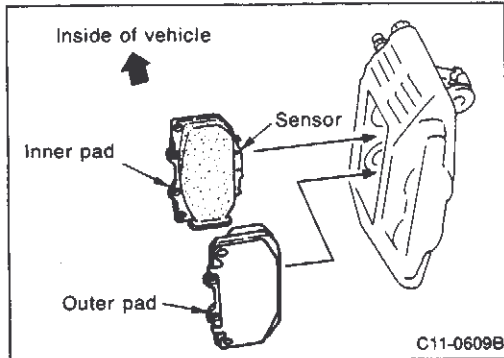

- Assemble pad so sensor faces inside of vehicle.

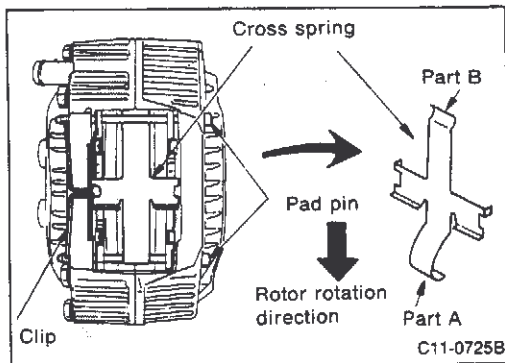

- Insert lower pad pin securely from outer cylinder side through lower pad hole to inner cylinder side.
- Set part A of cross spring on lower pad pin as shown in figure. Press part B in and insert upper pad pin from outer cylinder side to inner cylinder side and secure with cross spring.

CAUTION:

If the cross spring installation direction and position are incorrect it may cause squeaking or abnormal noise.

- Insert clip securely in small hole in the end of upper pad pin.
- Rotate pad pin and insert clip in the small hole in the end of pad pin. Next, insert curved projection in middle of clip into hole in middle of inner cylinder.

CAUTION:

- (1) If clip assembly is incorrect, the pad pin or pad itself may fall out during driving causing braking malfunction.
- (2) When replacing pads with new parts, bleed air from system.

[Point 2] Caliper removal and installation

CAUTION:

- (1) Do not remove four caliper inner and outer sides. Do not tighten these bolts.
- (2) The caliper and knuckle housing are manufactured of aluminum alloy and are softer than steel. Be sure to use a half-seat washer for the caliper washer to prevent scratching the installation surface.

C10 BRAKES

4. Removal and installation, Assembly and Disassembly (Cont'd)

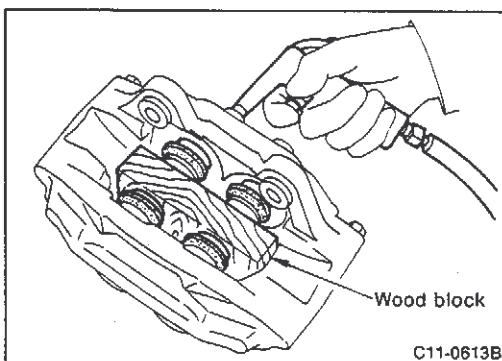
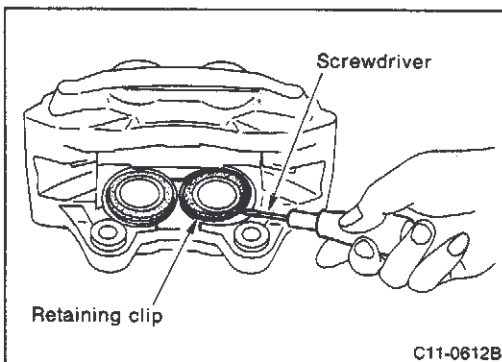
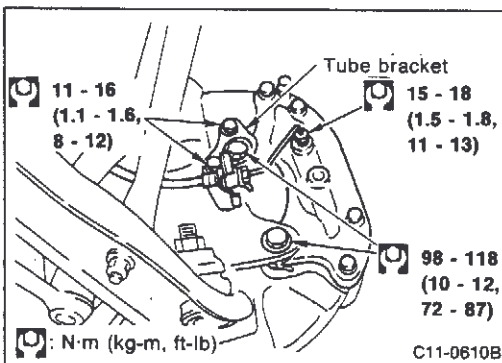
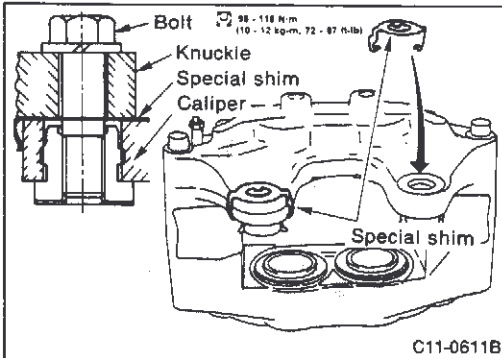
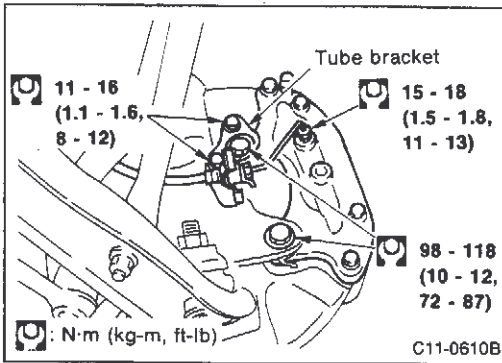

Removal

- Remove brake tube and tube bracket.
- Remove mounting bolts and remove calipers.

CAUTION:

Suspend caliper assembly with wire to prevent brake hose from stretching.

Installation

- Install special shims on both sides of caliper as shown in figure. Next, install knuckle housing.

CAUTION:

- (1) The caliper and knuckle housing are manufactured of aluminum alloy and are softer than steel. Be especially careful not to damage the seating surface during installation because this may cause bolt looseness or abnormal operation noise.
 - (2) Make sure there is no water or oil on knuckle housing at caliper installation surface or threads, bolts and washers.
- Install calipers as shown in figure and tighten mounting bolts to specified torque.
 - Install brake tube and tube bracket and tighten to specified torque.

CAUTION:

Check that brake tubes are not twisted or bent.

[Point 3] Piston removal and installation

Removal

- Remove retaining ring with screwdriver.

- Insert wood block as shown in figure, blow compressed air into brake tube installation hole and to push out piston and boot. Adjust air so four pistons all extend the same distance from calipers.

CAUTION:

- (1) Be careful so brake fluid does not spray out.
- (2) When pressing out piston with compressed air, be careful so fingers are not pinched between wood and piston.

C10 BRAKES

4. Removal and Installation, Assembly and Disassembly (Cont'd)

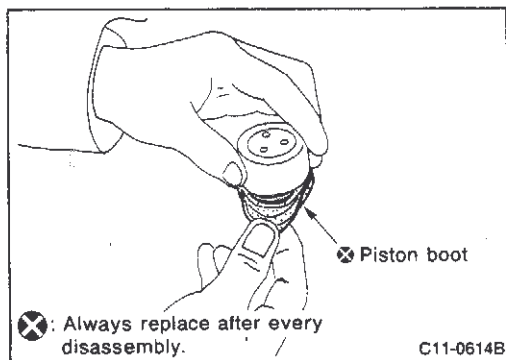

- Remove piston boot from piston.

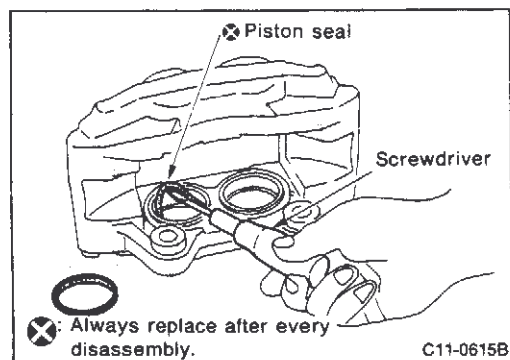

- Remove piston seal with screwdriver.

CAUTION:

- (1) Be careful not to scratch or score inside of cylinder with screwdriver.
- (2) Do not remove the four mounting bolts on the inner and outer side of caliper. Do not tighten bolts either.

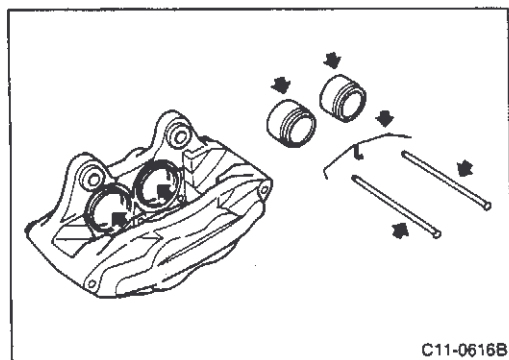

Disassembly inspection

- Check inside surface of cylinder and piston for damage, wear or rust. If any of these conditions are observed replace parts as necessary.
- If there is leakage from aligned surface of cylinder body or other problem, replace caliper assembly.
- Check pad pin, cross spring, clip and shim for damage, deformation or rust. Replace if any of these conditions are noted.

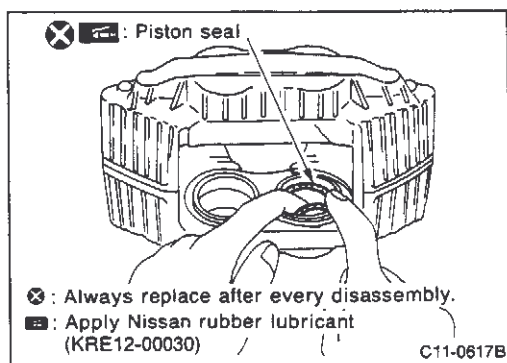

Installation

- Apply Nissan rubber lubricant to piston seal and install cylinder body.

C10 BRAKES

4. Removal and Installation, Assembly and Disassembly (Cont'd)

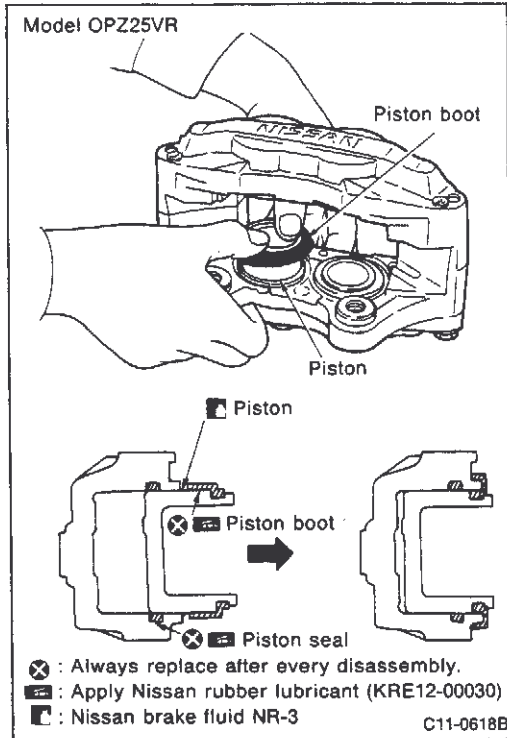

- Attach piston boot to rear of piston and install correctly in piston groove. (Apply rubber lubricant to boot before installing piston.)
- Insert piston in cylinder body by hand. Install cylinder lip correctly in piston boot groove.

CAUTION:

When pressing piston, change pressure position on piston to prevent insertion at incorrect angle.

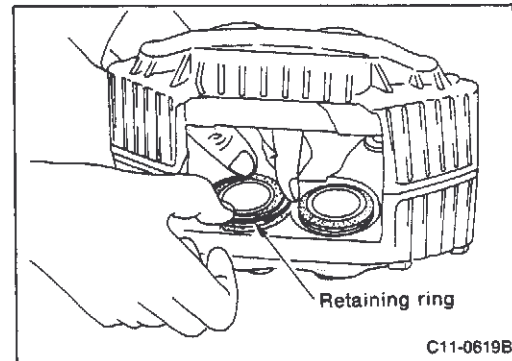

- Secure piston boot with retaining ring.

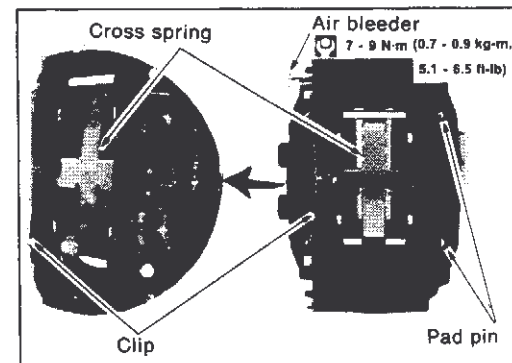

[Point 4] Misalignment inspection

- Assemble pad and bleed air from brakes. Press on brake pedal with approximately 196 N (20 kg, 44 lb) of force for 5 seconds.
- Release brake pedal, turn disc 10 times and check for misalignment or binding.

CAUTION:

- (1) The pad and disc must be dry.
- (2) The wheel bearing must be normal.

C10 BRAKES

4. Removal and Installation, Assembly and Disassembly (Cont'd)

4-6 REAR BRAKE

(1) Disc brake caliper assembly removal and installation, assembly and disassembly (model OPZ11VB)

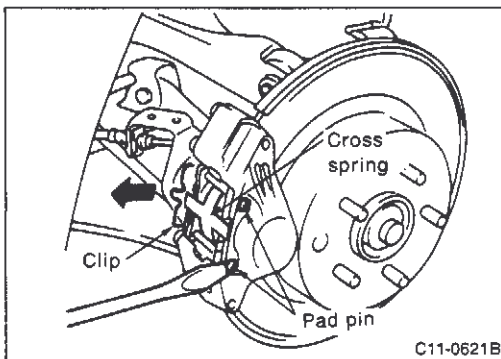
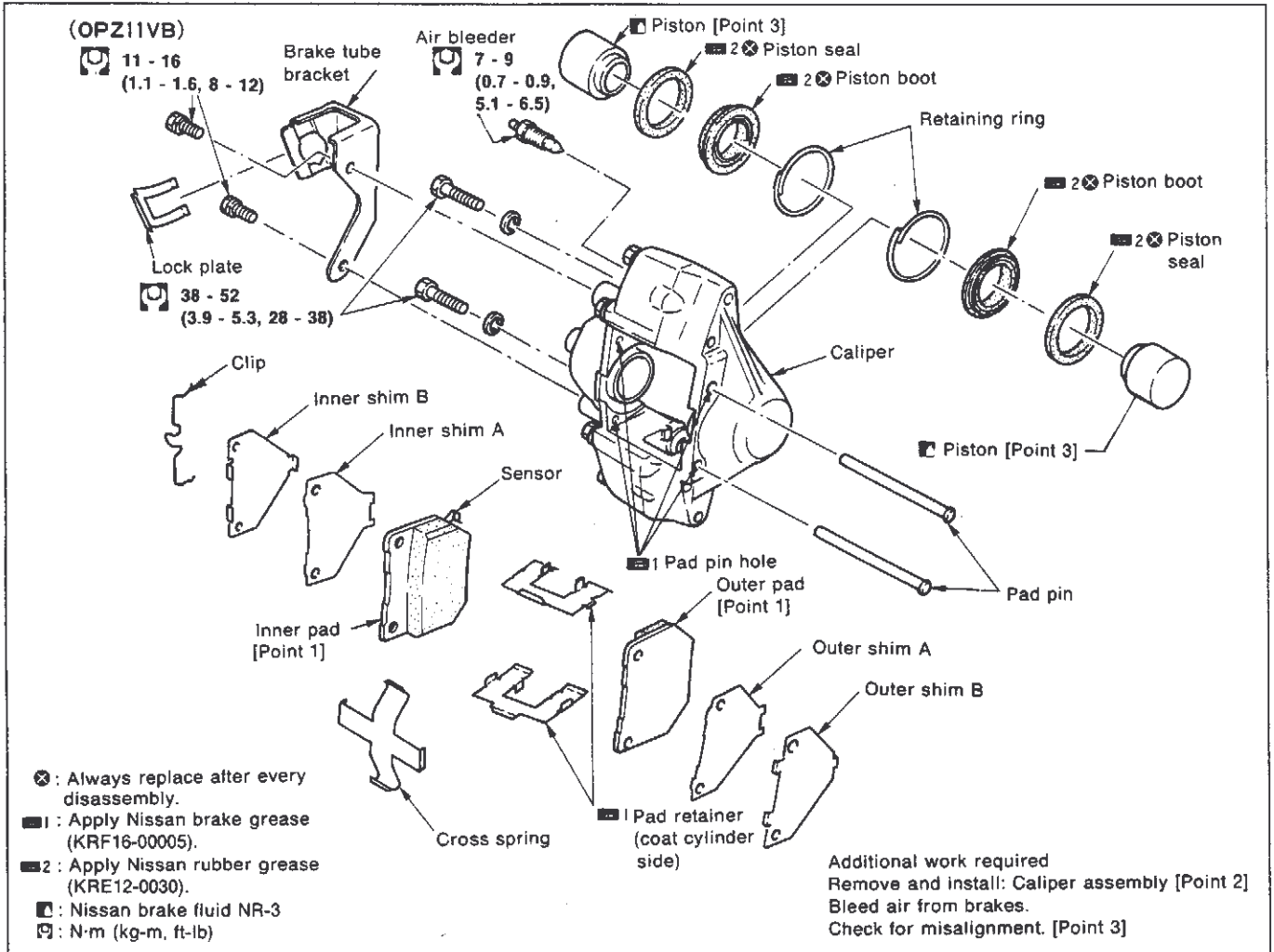

[Point 1] Pad removal and installation

Removal

- Remove clip from pad pin.
- While pressing cross spring by hand, remove pad pin.

CAUTION:

Check pad pin and clip for fatigue, damage and rust. If any of these conditions are observed, replace with new part.

C10 BRAKES

4. Removal and Installation, Assembly and Disassembly (Cont'd)

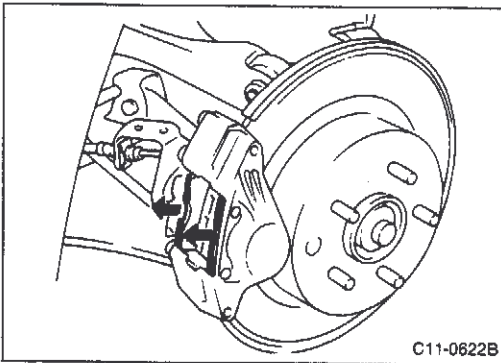

- Remove pad from calipers with shims attached.

CAUTION:

Check calipers and piston for fatigue, damage and rust. If any of these conditions are observed, replace with new part.

- Remove shims and shim cover from pad.

CAUTION:

If there is rust or a rubber peeling coat on shim and shim cover, replace with new parts.

Pad replacement

- If pad thickness exceeds wear limit indicated below, compress inner and outer pistons to install new pads.

Inspection specifications

Model	OPZ11VB	
Wear limit	mm (in)	2 (0.08)
(Reference) New pad thickness	mm (in)	11.5 (0.453)

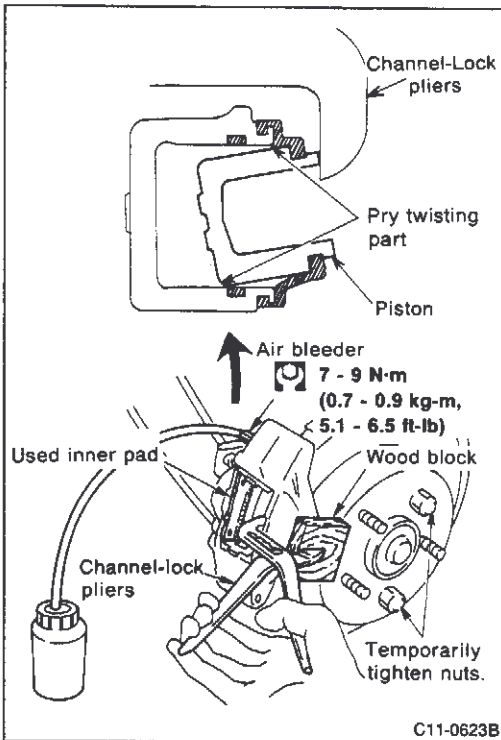

- Install old inner pad as shown in figure to prevent piston from popping out.
- Release air bleeder and use pliers to compress two outer pistons simultaneously. Place wood block on outside to prevent scratching calipers.

CAUTION:

- (1) Connect vinyl tube to air bleeder and be careful not to get brake fluid on body.
- (2) When pressing piston into calipers, change pressure position of outer pliers so piston does not jam in cylinder.
- (3) Temporarily tighten wheel nuts in criss-cross pattern so disc does not incline.

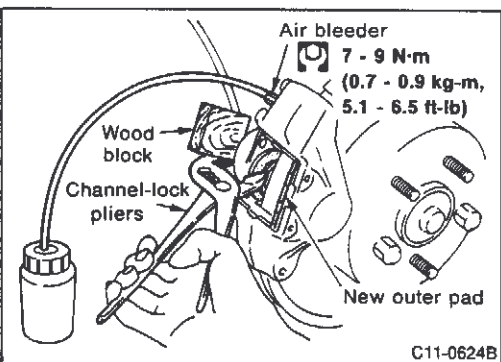

- Remove old inner pad and install new outer pad as shown in figure so outside piston does not pop out.
- Place wood on outer side as described above. Use pliers to compress two inner pistons simultaneously.
- Tighten air bleeder.
- Remove new outer pad to compress inner and outer pistons and complete operation.

CAUTION:

- (1) After replacing brake pads, bleed air from system.
- (2) Replace pads as a set on both left and right wheels at the same time.

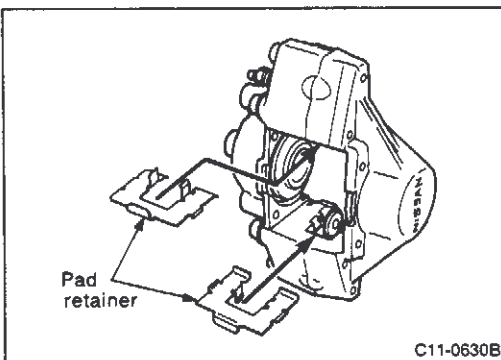

- Remove pad retainer from caliper.

C10 BRAKES

4. Removal and Installation, Assembly and Disassembly (Cont'd)

Installation

- Apply a uniform coat of Nissan brake grease to cylinder body side surface of pad retainer.

CAUTION:

- (1) Wipe off excess brake grease so it does not adhere to pad wear surface or caliper installation surface.
- (2) Install shims A and B in sequence shown in figure.
- (3) Apply grease to contact area between pad retainer and cylinder body because it may rust.

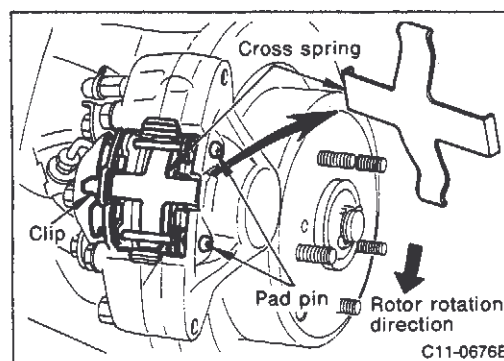
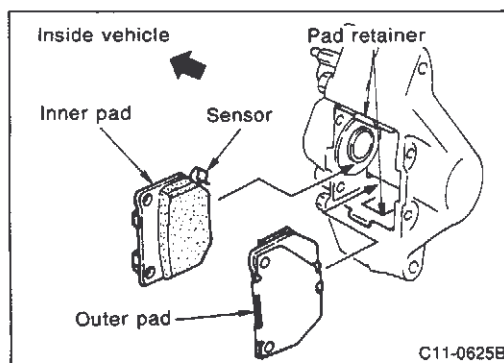
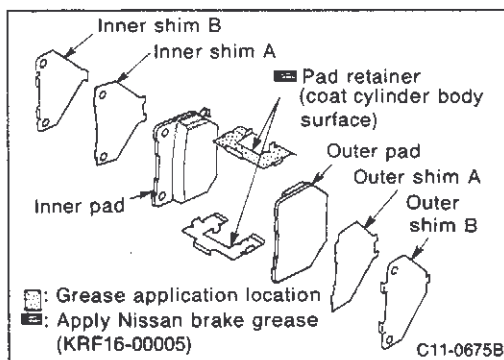

- Install pad retainer in caliper.
- Assemble pad so sensor faces inside of vehicle.

CAUTION:

Omission or incorrect assembly of pad retainer may cause abnormal brake noise.

- Insert lower pad pin securely from outer cylinder side through lower pad hole to inner cylinder side.
- Set cross spring on lower pad pin as shown in figure. Insert upper pad pin from outer cylinder side to inner cylinder side and secure with cross spring.

CAUTION:

If the cross spring installation direction and position are incorrect it may cause squeaking or abnormal noise.

- Using Phillips screwdriver (+), rotate pad pin and insert clip in the small hole in the end of pad pin.

CAUTION:

- (1) If clip assembly is incorrect, the pad pin or pad itself may fall out during driving causing braking malfunction.
- (2) When replacing pads with new parts, bleed air from system.

[Point 2] Caliper removal and installation

CAUTION:

- (1) Do not remove the four caliper inner nuts. Do not tighten these nuts.
- (2) The caliper and knuckle housing are manufactured of aluminum alloy and are softer than steel. Be sure to use a half-seat washer for the caliper washer to prevent scratching the installation surface.

C10 BRAKES

4. Removal and Installation, Assembly and Disassembly (Cont'd)

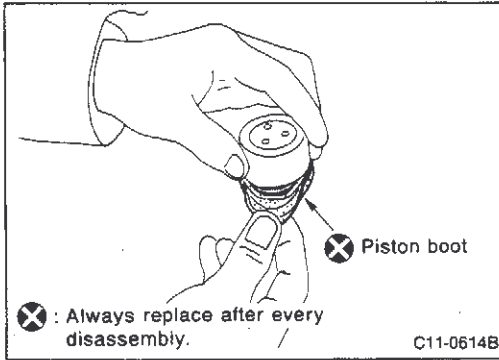

- Remove piston boot from piston.

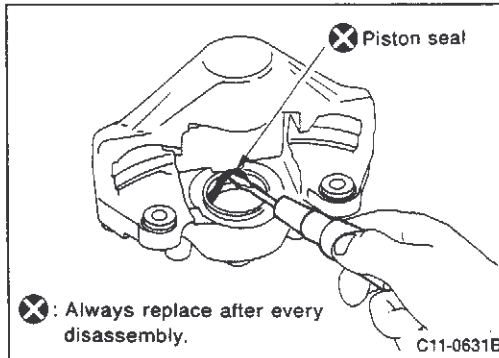

- Remove piston seal with screwdriver.

CAUTION:

- (1) Do not scratch or score inside of cylinder with screwdriver.
- (2) Do not loosen four mounting bolts on inner and outer side of caliper. Do not tighten these bolts either.

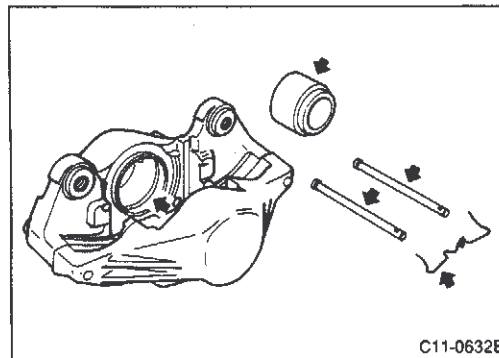

Disassembly inspection

- Check inner surface of cylinder for damage, wear or rust. If any of these conditions are noted, replace parts as necessary.
- If there is leakage from cylinder body mating surface or any other problem, replace caliper assembly.
- Check pad pin, pad retainer, cross spring, clip and shims for damage, deformation or rust. If any of these conditions are noted, replace parts as necessary.

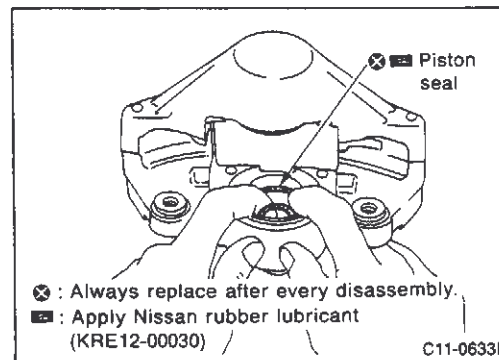

Installation

- Apply a coat of Nissan rubber lubricant to piston seal and install in cylinder.

C10 BRAKES

4. Removal and Installation, Assembly and Disassembly (Cont'd)

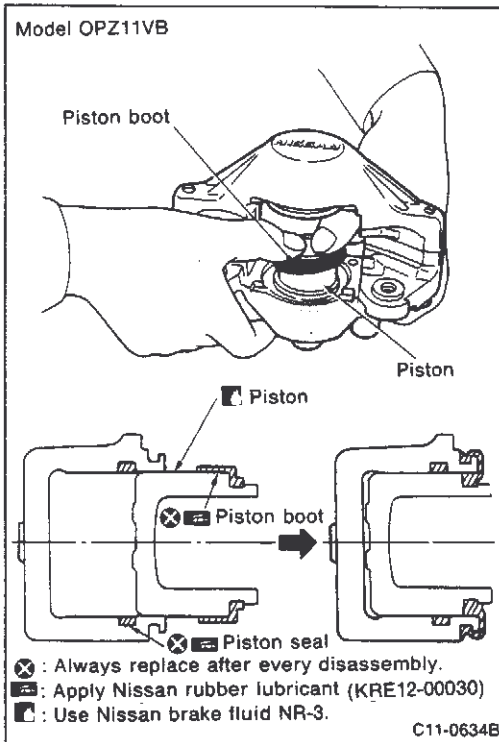

- Attach piston boot to rear of piston and install correctly in piston groove. (Apply Nissan rubber lubricant to boot before installing piston.)
- Insert piston in cylinder body by hand. Install cylinder lip correctly in piston boot groove.

CAUTION:

When pressing piston, change pressure position on piston to prevent insertion at incorrect angle.

- Secure piston boot with retaining ring.

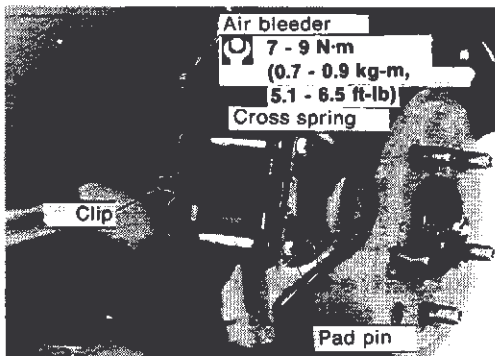

[Point 4] Misalignment inspection

- Install pad and bleed air from brakes. Press on pedal with 196 N (20 kg, 44 lb) for force of 5 sec.
- Release brake pedal and turn disc rotor 10 times. Check for misalignment at this time.

CAUTION:

- (1) Pad and disc must be dry.
- (2) Wheel bearings must be in normal condition.

C10 BRAKES

4. Removal and Installation, Assembly and Disassembly (Cont'd)

(2) Drum brake removal and installation, assembly and disassembly

Model DS17HD

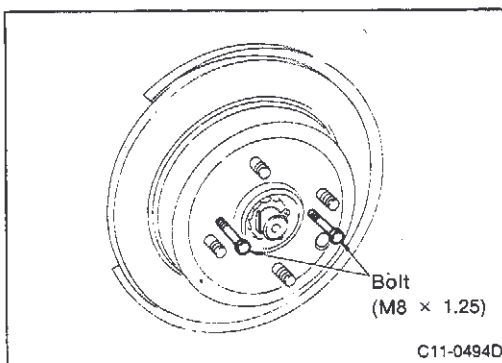
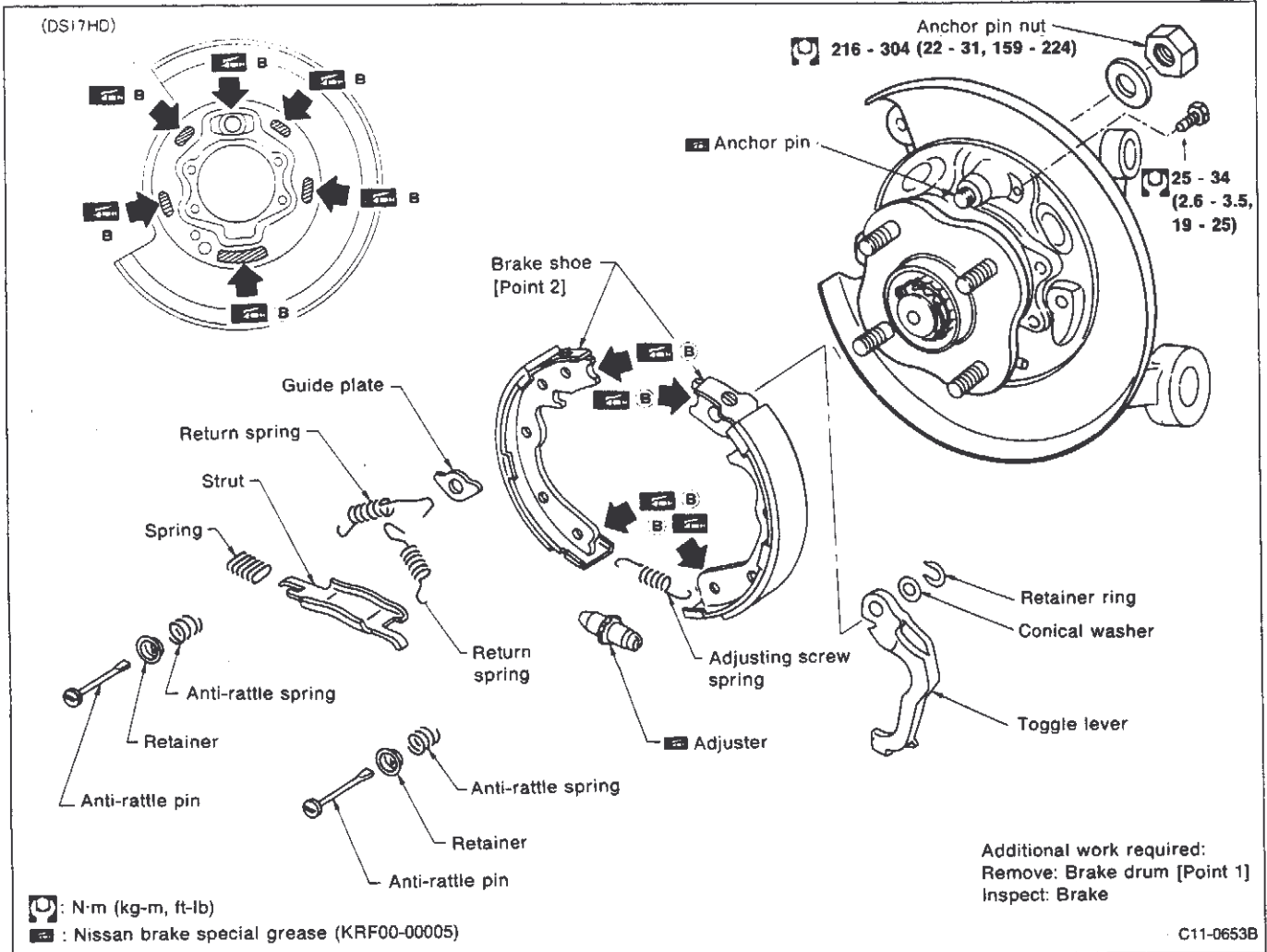

[Point 1] Brake drum removal

- Remove caliper assembly.
- Make sure parking brake lever and pedal are released completely.
- If drum is hard to remove, tighten two bolts gradually to free drum.

CAUTION:

Drum and baffle plate dust is collected in dust collector. Do not blow off with compressed air.

C10 BRAKES

4. Removal and Installation, Assembly and Disassembly (Cont'd)

- Use screwdriver and remove retainer ring and toggle lever.

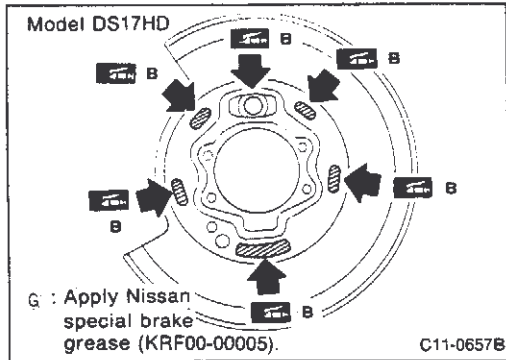
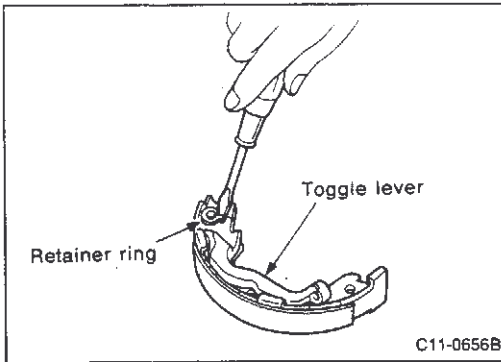

Installation

- Apply Nissan brake special grease to areas indicated by (■) in figure and then assemble.

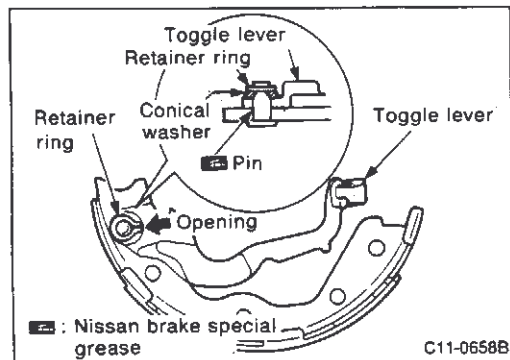

- Apply a coat of Nissan brake special grease to sliding part of toggle lever and install shoe as shown in figure.

CAUTION:

Caulk retainer ring opening unit connection.

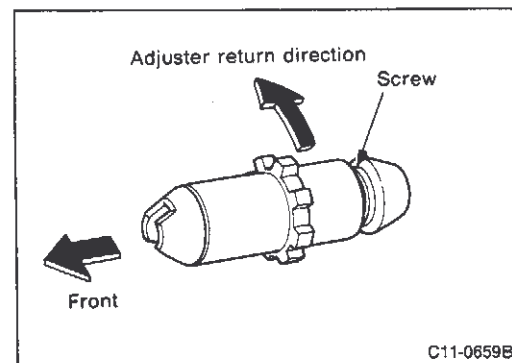

- Turn screws of adjuster to rear side because left and right installation direction is different. Assemble adjuster so the screws widen if turned in direction of arrow.

CAUTION:

- (1) When adjuster is disassembled, coat screw with Nissan brake special grease.
- (2) Assemble adjuster in compressed condition.

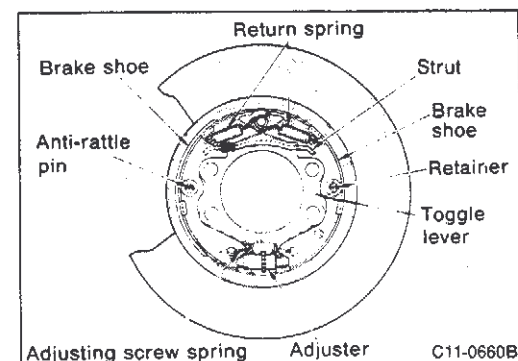

- After assembly, check that each part is installed correctly.

CAUTION:

Return spring is assembled from leading shoe side.

- Measure inside diameter of drum. Widen adjuster so outer diameter from middle of shoe to inner side of drum is less than 0.35 to 0.55 mm (0.0138 to 0.0217 in).
- Adjust disc rotor with wheel nut to adjust shoe clearance. Refer to "2. On-vehicle Inspection, 2-15 PARKING BRAKE INSPECTION AND ADJUSTMENT" for adjustment procedures.

C10 BRAKES

4. Removal and Installation, Assembly and Disassembly (Cont'd)

4-7 PARKING BRAKE

(1) Control lever and cable removal and installation, assembly and disassembly

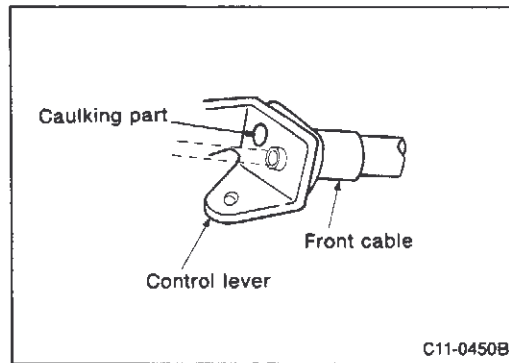
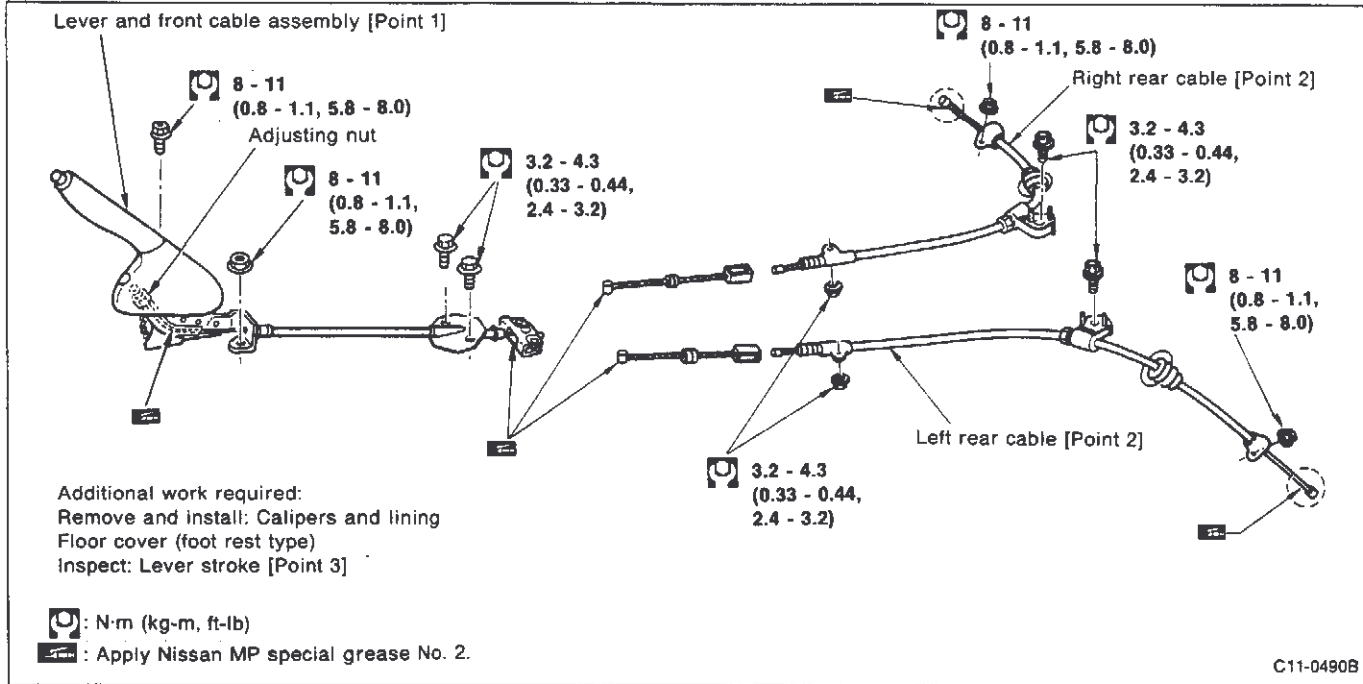

[Point 1] Lever and front cable assembly

- Knock off caulking from control lever with hammer as shown in figure and replace with new part.

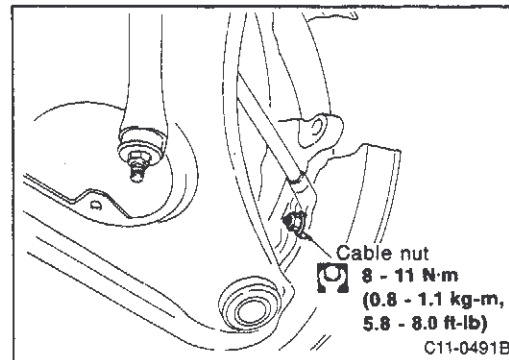

[Point 2] Rear cable removal and installation

Removal

- Remove caliper and disc.
- Remove cable nuts as shown in figure, and separate brake lining.

C10 BRAKES

4. Removal and Installation, Assembly and Disassembly (Cont'd)

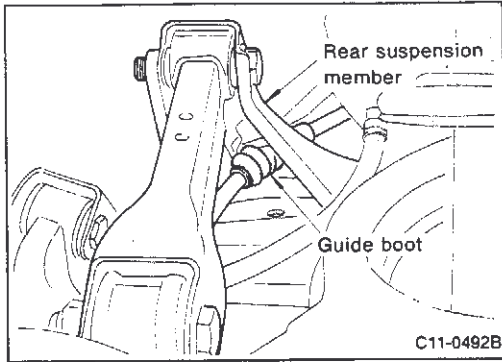

- Remove rear cable bolt. Pry off guide boot in middle of suspension member so it is free and then remove guide.

Installation

- Assembly is the reverse of disassembly.

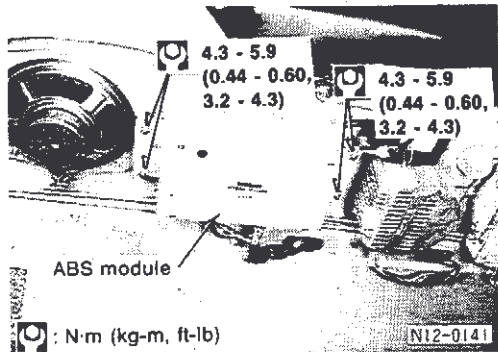

4-8 ELECTRICAL CONTROL 4WD ABS MODULE REMOVAL AND INSTALLATION

(1) ABS module removal and installation

- The module is installed in the bottom of rear parcel shelf in trunk.
- The ground is installed in the top of the rear parcel shelf.

(2) Actuator removal and installation

CAUTION:

Always remove battery terminal before actuator removal and installation.

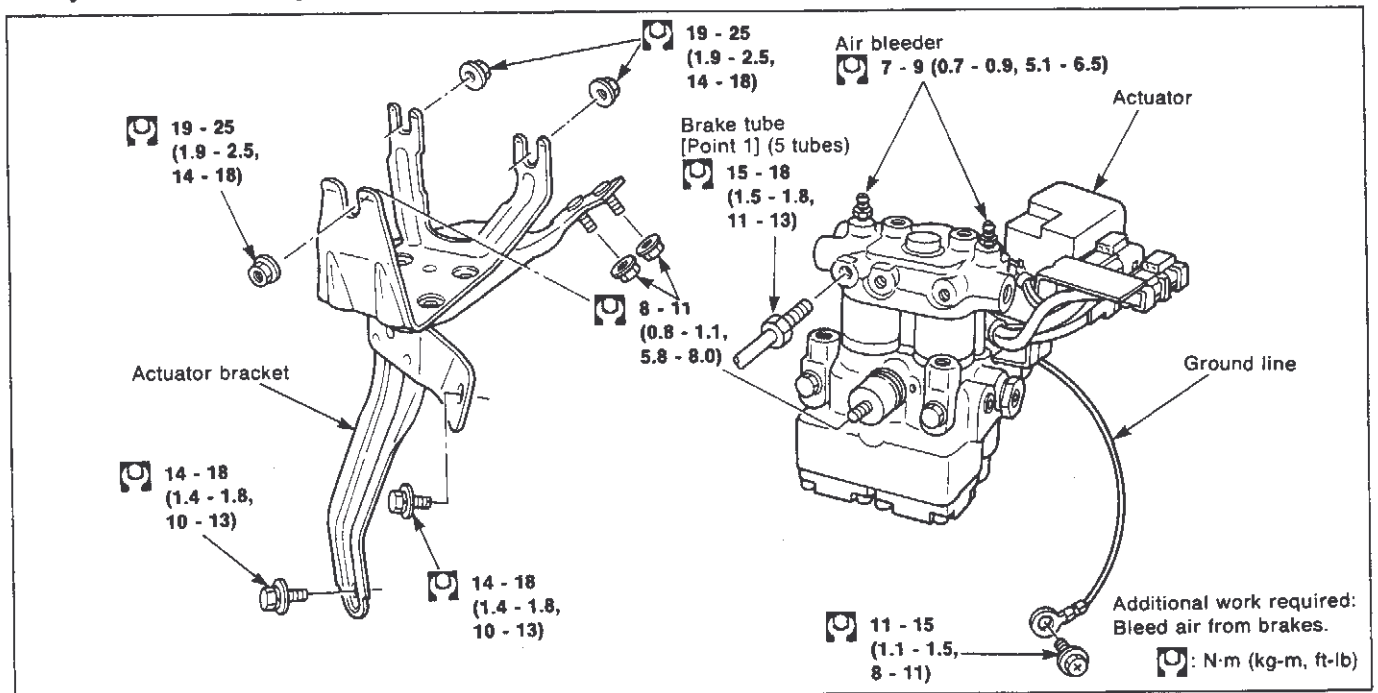

C10 BRAKES

4. Removal and Installation, Assembly and Disassembly (Cont'd)

[Point 1] Brake tube removal and installation

Removal

- Use brake flare nut wrench and remove brake tube flare nuts.

Installation

- Using brake tube torque wrench (special service tool) as shown in figure, install brake pipes. Be careful not to damage pipes or flare nuts.

CAUTION:

Refer to 2-3 CHANGING BRAKE FLUID AND AIR BLEEDING for air bleeding procedures.

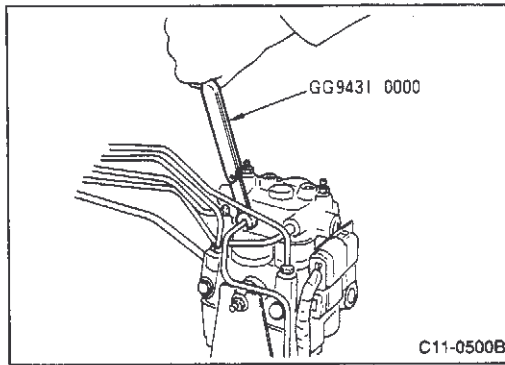

C11 STEERING

PRECAUTIONS

The disassembly and repair of power steering gear and pump is performed for oil leakage, noise and abnormal steering power.

(1) Part replacement

Oil leak repair is not only the replacement of leak location oil seals and O-rings. The parts specified in this manual are always replaced as kit or entire assembly. Never reuse parts as this may cause fluid leaks.

(2) Protection against foreign matter

Power steering gear and oil pump are precision hydraulic mechanisms and all disassembly should be performed in a clean work area. It is important to prevent the internal parts from becoming contaminated by dirt or other foreign matter.

- ① Perform assembly and disassembly operations in a vise with copper plates to protect the secured parts. Use nylon cloth or paper towels to clean the parts. Do not use common shop rags because they can leave lint, dust or metallic powder on gears or in the pump housing. Do not wear gloves and perform all operations with clean, bare hands.
- ② Wash disassembled parts (except rubber parts) with white gasoline and dry off with compressed air or paper towels to remove all oil.

CAUTION:

Never use cloth rags.

Do not wash rubber parts with white gasoline. Clean off with compressed air or paper towels.

- ③ Store disassembled parts (including new rubber parts) on a work bench where they will not be scratched or damaged.
- ④ Before assembly, wash mating surfaces of each part again (except rubber parts) with white gasoline. Dry with compressed air (or paper towels) and store in a parts rack so they can be reinstalled in their proper positions and sequence.

When an operation must be interrupted, indicate "disassembly" and cover parts with a clean cover.



CAUTION:

A special dust-proof area is not required but all assembly and disassembly should be done in a clean work area. It is important to prevent the internal parts from being contaminated by dirt or other foreign matter.

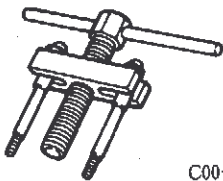
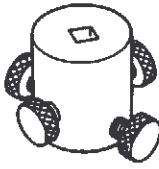
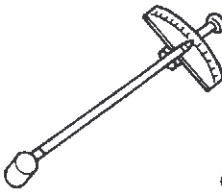
SPECIAL SERVICE TOOLS

Tool name Tool number	Description	
Steering wheel puller ST2718 0001	 C00-0036	Removing steering wheel
Torque adapter KV481 3400	 C00-0040	Measuring steering gear pinion rotating torque
Preload gauge ST3127 S000	 C00-0039	Measuring steering gear pinion rotation torque and ball joint sliding torque.

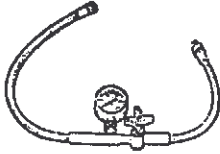
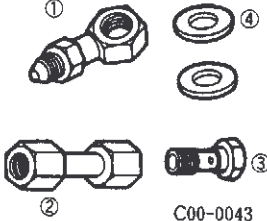
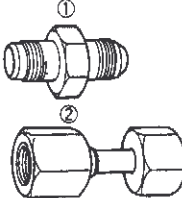
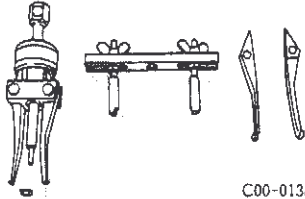
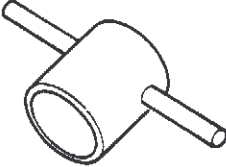
C11 STEERING

Tool name Tool number	Description	
Oil pressure gauge KV481 03500 (former ST2909 1000)	 <p style="text-align: right;">C00-0042</p>	Measuring oil pump pressure
Pressure gauge adapter KV481 02500 <ul style="list-style-type: none"> ① KV481 02500-01 (I-joint) ② KV481 02500-02 (flare joint) ③ KV481 02500-03 (bolt) ④ KV481 02500-04 (washer) 	 <p style="text-align: right;">C00-0043</p>	Same as above
Pressure gauge adapter KV481 00410 <ul style="list-style-type: none"> ① KV481 00400-1 ② KV481 00400-2 	 <p style="text-align: right;">C00-0238</p>	Same as above
Oil seal puller ST3329 0001	 <p style="text-align: right;">C00-0138</p>	Removing oil seals
Teflon ring correction tool KV481 04400	 <p style="text-align: right;">C00-0142</p>	Assembling steering gear
Wrench KV481 04300	 <p style="text-align: right;">C00-0143</p>	Removing electronic control oil pump solenoid

C11 STEERING

COMMERCIAL SERVICE TOOLS

Tool name Tool number	Description		
Pitman arm puller HT7256 0000	 C00-0231	Removing tie-rod	
Measurement tools	Dial gauge	Gear housing transfer quantity inspection	
	Spring balance	Checking ball joint swing torque	

C11 STEERING

1. Summary

Specifications

		Engine	RB26DETT
		Steering control system	Twin orifice power steering system
Description			
Steering wheel	Outer diameter	mm (in)	370 (14.57)
	Number of turns (lock to lock)		2.6
Steering column	Model		Collapsible (steel ball type)
	Tilt distance	mm (in)	30 (1.18)
	Telescope distance	mm (in)	35 (1.38)
Steering gear	Model		Rack and pinion
	Model number		PR26SE (Rotary valve twin-orifice)
	Part number (49001)		05U00
Pump	Model		Fixed injection type
	Part number (49110)		05U00 (RB26DETT)
Maximum steering angle (°)	Inner wheel		38° ^{+1°} _{-3°}
	Outer wheel		31°
Operation oil		Nissan power steering fluid	

Inspection specifications

Description	Standard value								
Steering wheel play mm (in)	0 - 35 (0 - 1.38)								
Steering wheel standard torque N·m (kg·m, ft·lb)	10 (1.0, 7) max.								
Gear housing movement mm (in)	± 2 (± 0.08) max.								
Power steering belt tension adjustment value [when 98 N (10 kg, 22 lb) of force is applied] mm (in)	<table border="1" style="width: 100%; border-collapse: collapse;"> <thead> <tr> <th>Slack distance Engine</th> <th>New value</th> <th>Adjustment value</th> <th>Adjustment limit</th> </tr> </thead> <tbody> <tr> <td>RB26DETT models</td> <td>8 - 10 (0.31 - 0.39)</td> <td>10 - 11 (0.39 - 0.43)</td> <td>16 (0.63)</td> </tr> </tbody> </table>	Slack distance Engine	New value	Adjustment value	Adjustment limit	RB26DETT models	8 - 10 (0.31 - 0.39)	10 - 11 (0.39 - 0.43)	16 (0.63)
Slack distance Engine	New value	Adjustment value	Adjustment limit						
RB26DETT models	8 - 10 (0.31 - 0.39)	10 - 11 (0.39 - 0.43)	16 (0.63)						
Operation oil	<p style="text-align: center;">Nissan power steering fluid</p> <table border="1" style="width: 100%; border-collapse: collapse;"> <tr> <td>Steering gear</td> <td>PR26SE</td> </tr> <tr> <td>Fluid capacity ℓ (Imp qt)</td> <td>Approx. 0.9 (3/4)</td> </tr> </table>	Steering gear	PR26SE	Fluid capacity ℓ (Imp qt)	Approx. 0.9 (3/4)				
Steering gear	PR26SE								
Fluid capacity ℓ (Imp qt)	Approx. 0.9 (3/4)								

C11 STEERING

1. Summary (Cont'd)

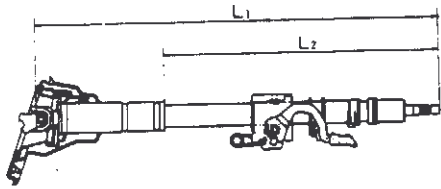
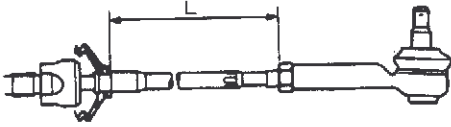
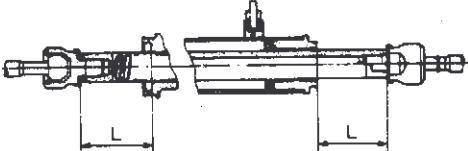
Description	Standard value																						
Steering gear pinion rotation torque and rack sliding force	Steering gear		PR26SE																				
	Description																						
	Pinion rotational torque N·m (kg-m, ft-lb)	Measured one full turn from neutral position	Average value	0.8 - 1.3 (0.08 - 0.13, 0.6 - 0.9)																			
			Maximum variation	0.4 (0.04, 0.3 max.)																			
	Other than above	Maximum value	1.9 (0.19, 1.4 max.)																				
Maximum variation		0.6 (0.06, 0.4 max.)																					
Rack sliding force	N (kg, lb)	Average value	167 - 226 (17 - 23, 37 - 51)																				
<p>Note: Numeric values indicate performance when unit is not filled with specified fluid.</p>																							
Steering column length	mm (in)	$L_1 = 685.5 - 720.5$ (26.99 - 28.37) $L_2 = 423.4 - 458.4$ (16.67 - 18.05)	 C12-0641C																				
Tie-rod length	mm (in)	PR26SE model $L = 126.5$ (4.98)	 C08-0683B																				
Rack neutral position	mm (in)	PR26SE model $L = 66.5$ (2.618)	 C12-0423B																				
Tie-rod ball joint		<table border="1" style="width: 100%; border-collapse: collapse;"> <thead> <tr> <th style="width: 35%;"></th> <th style="width: 20%;">Ball joint</th> <th style="width: 20%;">Inner socket</th> <th style="width: 25%;">Outer socket</th> </tr> </thead> <tbody> <tr> <td style="text-align: center;">Description</td> <td></td> <td></td> <td></td> </tr> <tr> <td style="text-align: center;">Sliding torque</td> <td style="text-align: center;">N·m (kg-m, ft-lb)</td> <td style="text-align: center;">—</td> <td style="text-align: center;">0.3 - 2.9 (0.03 - 0.3, 0.2 - 2.2)</td> </tr> <tr> <td style="text-align: center;">Swinging torque</td> <td style="text-align: center;">N·m (kg-m, ft-lb)</td> <td style="text-align: center;">1 - 9 (0.1 - 0.9, 0.7 - 6.5)</td> <td></td> </tr> <tr> <td style="text-align: center;">Axial end play [axial load 490 N (50 kg, 110 lb)]</td> <td style="text-align: center;">mm (in)</td> <td style="text-align: center;">0 (0)</td> <td style="text-align: center;">0.5 (0.020) max.</td> </tr> </tbody> </table>		Ball joint	Inner socket	Outer socket	Description				Sliding torque	N·m (kg-m, ft-lb)	—	0.3 - 2.9 (0.03 - 0.3, 0.2 - 2.2)	Swinging torque	N·m (kg-m, ft-lb)	1 - 9 (0.1 - 0.9, 0.7 - 6.5)		Axial end play [axial load 490 N (50 kg, 110 lb)]	mm (in)	0 (0)	0.5 (0.020) max.	
	Ball joint	Inner socket	Outer socket																				
Description																							
Sliding torque	N·m (kg-m, ft-lb)	—	0.3 - 2.9 (0.03 - 0.3, 0.2 - 2.2)																				
Swinging torque	N·m (kg-m, ft-lb)	1 - 9 (0.1 - 0.9, 0.7 - 6.5)																					
Axial end play [axial load 490 N (50 kg, 110 lb)]	mm (in)	0 (0)	0.5 (0.020) max.																				

C11 STEERING

2. On-vehicle Inspection and Adjustment

2-1 MAXIMUM STEERING WHEEL PLAY INSPECTION (Inspect with wheels at turning angle.)

- Refer to C7 Front Suspension and Axle.

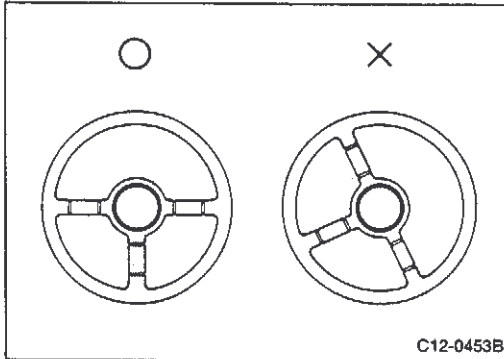

2-2 STEERING WHEEL NEUTRAL POSITION INSPECTION

- Set wheels straight-ahead and visually check that steering wheel play from neutral position.
- If it is not within specification, remove steering wheel and reinstall it correctly so it is in neutral position.
- If the neutral position is between two serrated teeth loosen tie-rod lock nut and move tie-rod in the opposite direction by the same amount on both left and right sides to compensate for error in the neutral position.

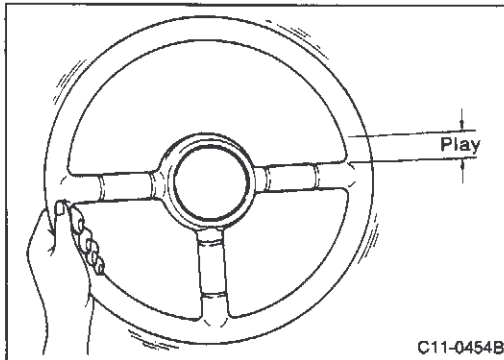

2-3 STEERING WHEEL PLAY INSPECTION

- Set tires in straight-ahead position. Start engine and turn steering wheel lightly. Measure distance until wheels start to move and check if it is within specified range.

Play distance specification value:

0 - 35 mm (0 - 1.38 in)

CAUTION:

Measure outside of steering wheel to determine play distance.

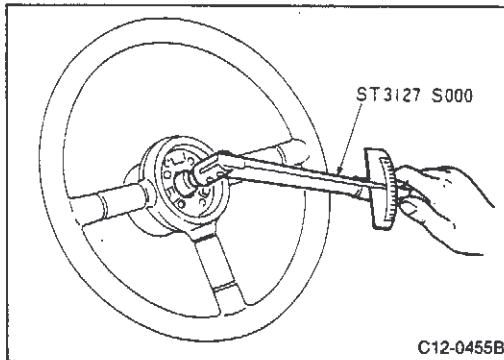

2-4 STEERING WHEEL STANDARD TORQUE INSPECTION

- Set vehicle on flat, dry paved road when power steering unit is warm (engine is warmed up). Measure steering wheel rotational torque with preload gauge (special service tool) when engine is running.
- Measure left and right turns.

Standard torque (dry, paved road):

10 N·m (1.0 kg·m, 7 ft·lb) max.

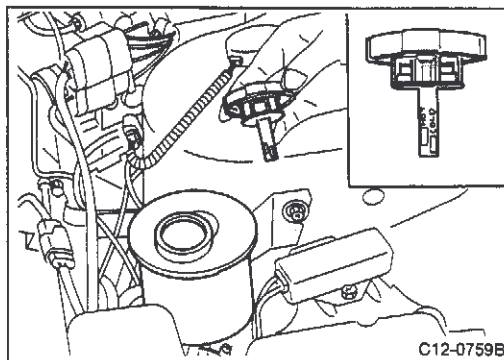

2-5 FLUID LEVEL INSPECTION

- The fluid level should be within the marks in level gauge. Do not overfill because fluid will drip from cap.
- Check that level gauge has HOT and COLD ranges as shown in figure.

HOT	50 - 80°C (122 - 176°F)
COLD	0 - 30°C (32 - 86°F)

C11 STEERING

2. On-vehicle Inspection and Adjustment (Cont'd)

CAUTION:

- (1) Never reuse steering fluid which has been removed.
- (2) Do not mix Nissan Steering Fluid and Nissan Special Steering Fluid.
- (3) Never use Nissan matic C or D fluid.

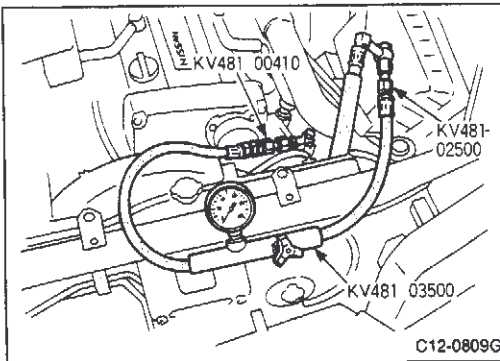

Steering model number	Relief hydraulic specification kPa (kg/cm ² , psi)
PR26SE models	5,884 - 6,865 (60 - 70, 853 - 995)

2-6 OIL PUMP RELIEF PRESSURE INSPECTION

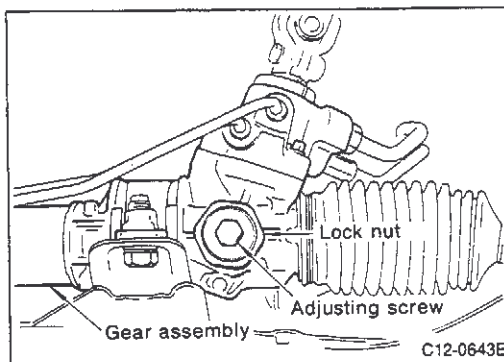
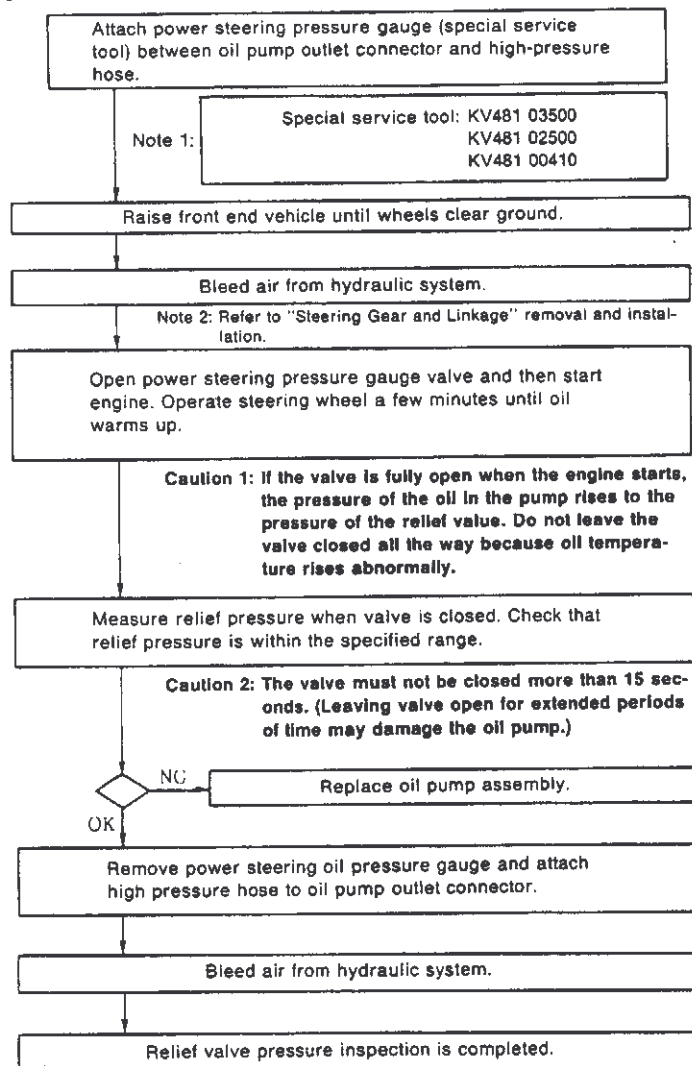

2-7 ADJUSTING SCREW INSPECTION

- Perform operation test described below on level road. If any abnormality is noted, check adjusting screw and return it to normal position.

① Linearity

- a) Place wheels in straight-ahead position and remove hands from wheel. Check if wheel can maintain straight-ahead position.
- b) If wheel cannot be placed in straight-ahead position, loosen adjusting screw.

C11 STEERING

2. On-vehicle Inspection and Adjustment (Cont'd)

② Restoration

- Turn the steering wheel slightly (approx. 20° - 30°) and release wheel. Check that steering wheel returns to neutral position.
- If return motion is poor, loosen adjusting screw slightly.

CAUTION:

The adjusting screw range is $\pm 90^\circ$. After adjustment, remove lock nut again and remove dust and debris from seal material. Coat the lock nut with sealant (silicon bond TB1111B or equivalent) and tighten lock nut to specified torque.

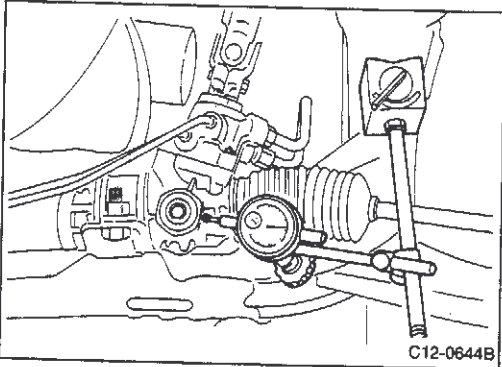

2-8 GEAR HOUSING MOVEMENT INSPECTION

- The steering gear housing operation during stationary turns varies according to the elastic deformation of insulator. The movement limit is indicated below.

Gear housing movement limit:

$\pm 2 \text{ mm } (\pm 0.08 \text{ in})$ (on dry, paved road)

Note: This movement is the distance the gear housing moves when 49 N (5 kg, 11 lb) of force is applied to the end of steering wheel with wheels set in straight-ahead position. (Ignition switch is OFF at this time.)

- If movement is not within specification range, check gear assembly mount bracket and replace mount insulator if necessary.

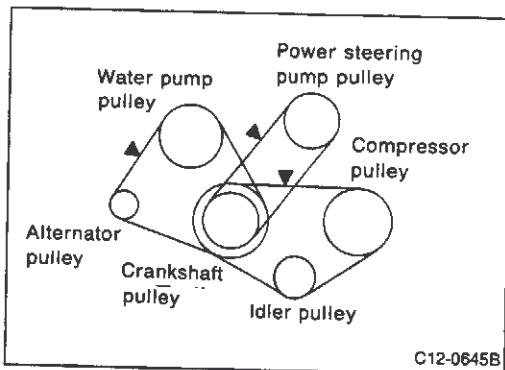

2-9 BELT TENSION INSPECTION AND ADJUSTMENT

Belt tension inspection

- Inspect belt tension when engine is cold.
- Apply 98 N (10 kg, 22 lb) of force at positions indicated by arrow marks (▲) in figure and measure belt slack distance.

Specification

		Unit: mm (in)		
Engine	Slack distance	New part	Adjusted	Tension limit
	RB26DETT models		8 - 10 (0.31 - 0.39)	10 - 11 (0.39 - 0.43)

Belt tension adjustment

- Adjust belt slack if it is less than specification (too tight) or greater than specification (too loose).

C11 STEERING

2. On-vehicle Inspection and Adjustment (Cont'd)

2-10 LEAKAGE INSPECTION

Precautions

- ① Check type of oil at leakage location. (Power steering fluid is red.)
- ② When leakage location is not clear, wash area with white gasoline or other solvent. (In vehicles equipped with electrically controlled power steering, do not wash harnesses or connectors directly with white gasoline or solvent. Wipe fluid off with rags immediately if fluid is attached.) Check leak positions again.
- ③ When repairing parts, check related parts thoroughly and replace defective parts as necessary.

(1) Leakage position inspection

PR26SE model power steering

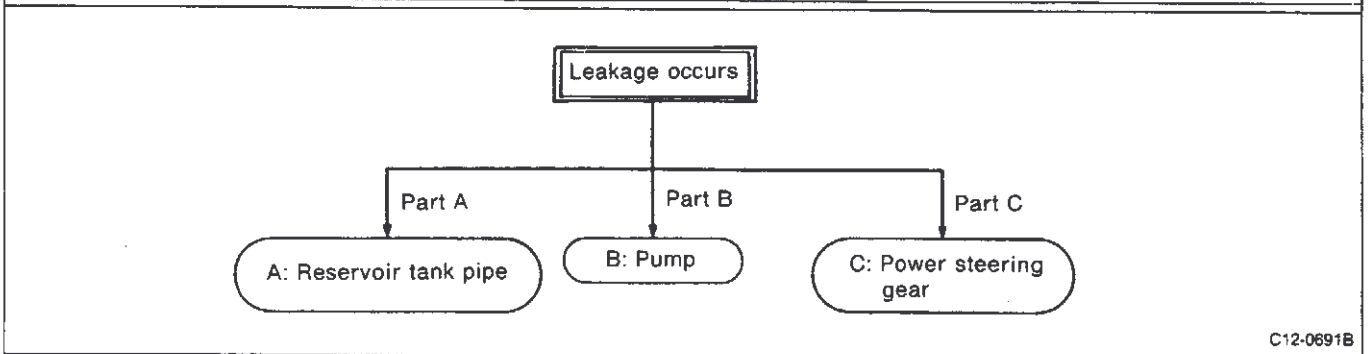
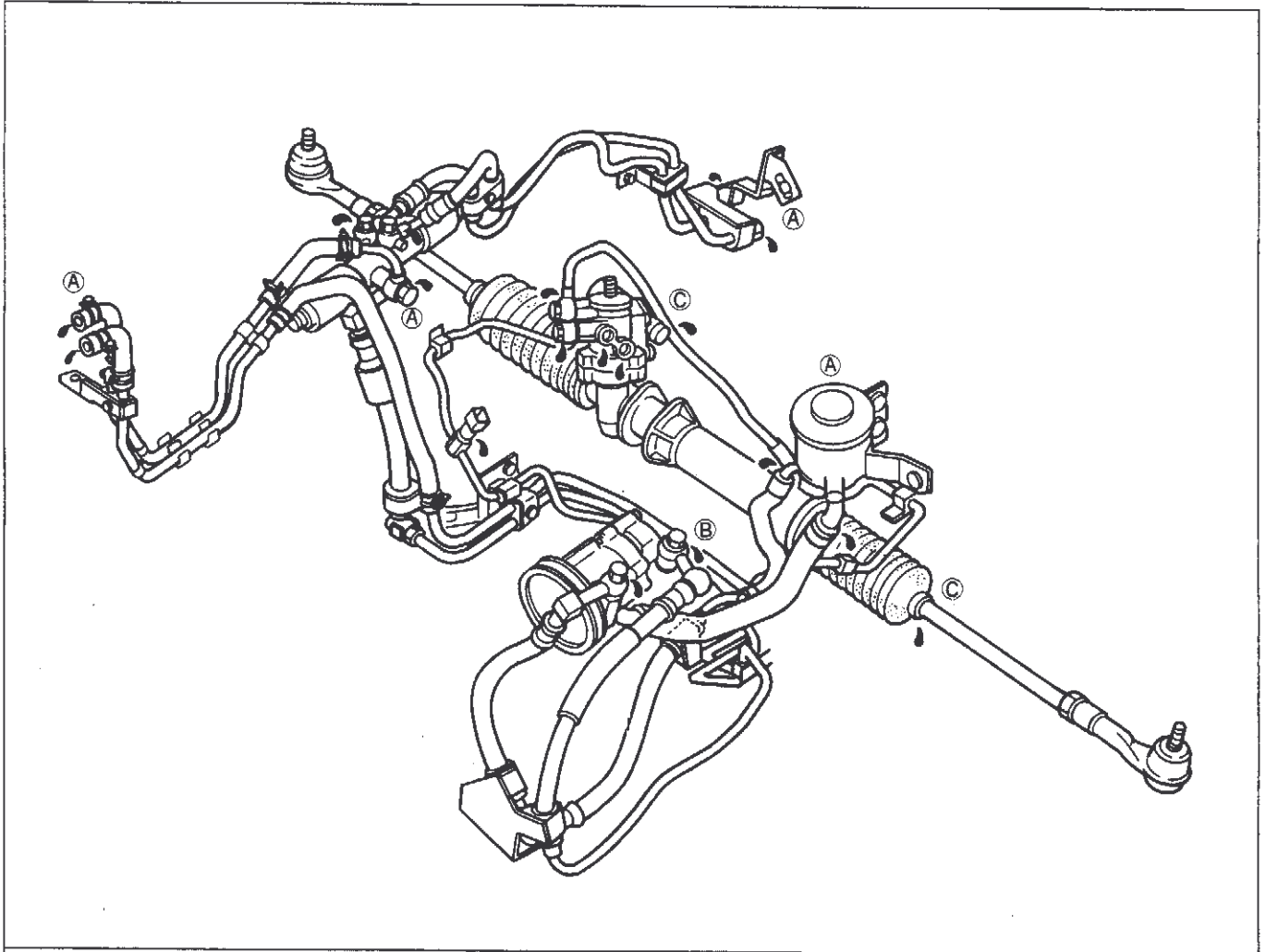

C12-0691B

C11 STEERING

2. On-vehicle Inspection and Adjustment (Cont'd)

(2) Leaks from part ① (Reservoir tank or pipes)

Leak position	<ul style="list-style-type: none"> ● Reservoir tank cap 	<ul style="list-style-type: none"> ● Low-pressure pipe & clamp 	<ul style="list-style-type: none"> ● Other
Repair description (replacement parts)	<ul style="list-style-type: none"> ● Reservoir tank cap 	<ul style="list-style-type: none"> ● Low-pressure hose ● & clamp 	<ul style="list-style-type: none"> ● Tube ● High pressure hose ● Reservoir tank
Related parts requiring inspection	<ul style="list-style-type: none"> ● Reservoir tank 	<ul style="list-style-type: none"> ● Tube ● Reservoir tank 	—

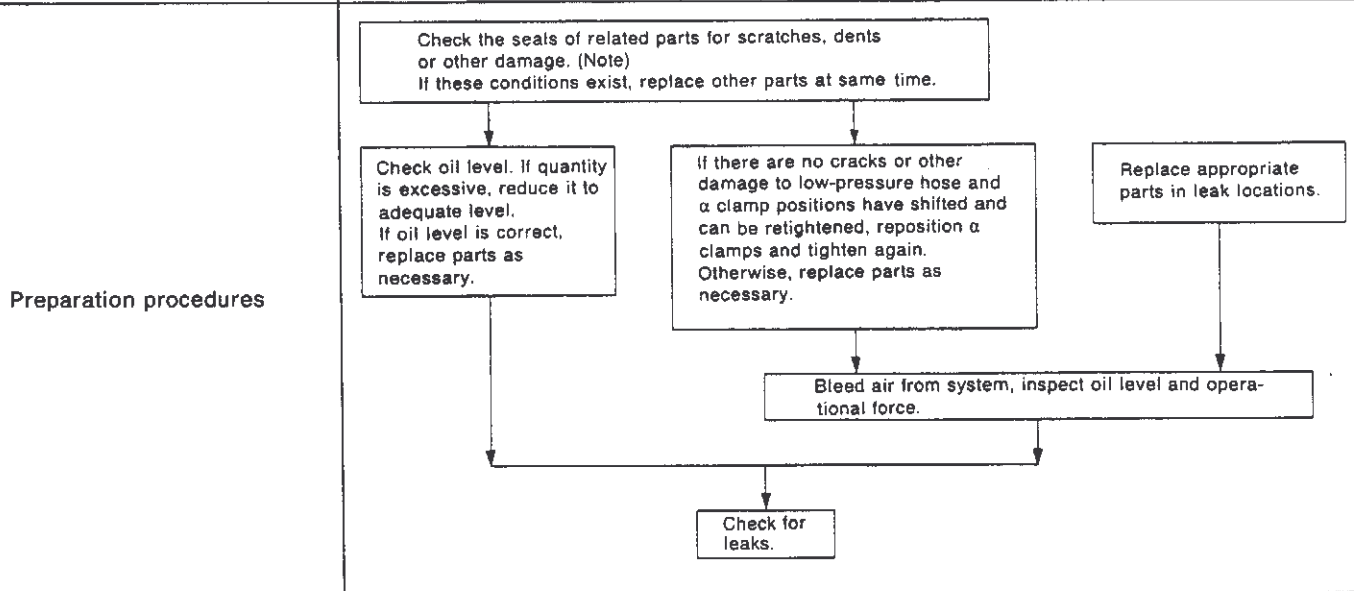

Note: The standard for replacing related parts is if a fingernail scrapes or catches in a scratch.

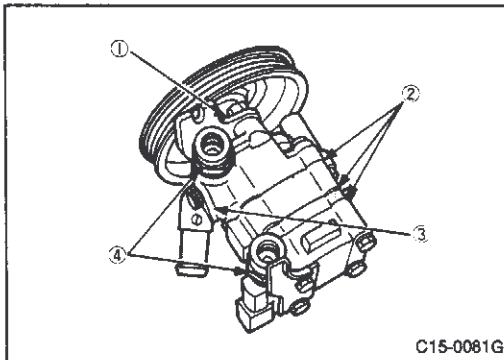

(3) Oil leak from part ② (pump)

Oil pump leak repair is separated into four types of repair depending on the leak location. Perform the suitable repair procedure for the leak location.

C11 STEERING

2. On-vehicle Inspection and Adjustment (Cont'd)

Leak location	① Drive shaft oil seal	② Housing	③ Inlet connector	④ Outlet connector
Preparation description (replacement parts)	[Kit] ● Oil seal ● Snap ring ● Inner O-ring ● Outer O-ring ● Gasket ● O-ring (inlet connector)	● O-ring (inlet connector)	● O-ring (inlet connector)	● O-ring (2) (flow control valve)
Related parts requiring inspection	● Drive shaft	● Front housing ● Rear housing	● Inlet connector ● Front housing	● Outlet connector ● Front housing ● Rear housing

Preparation procedures

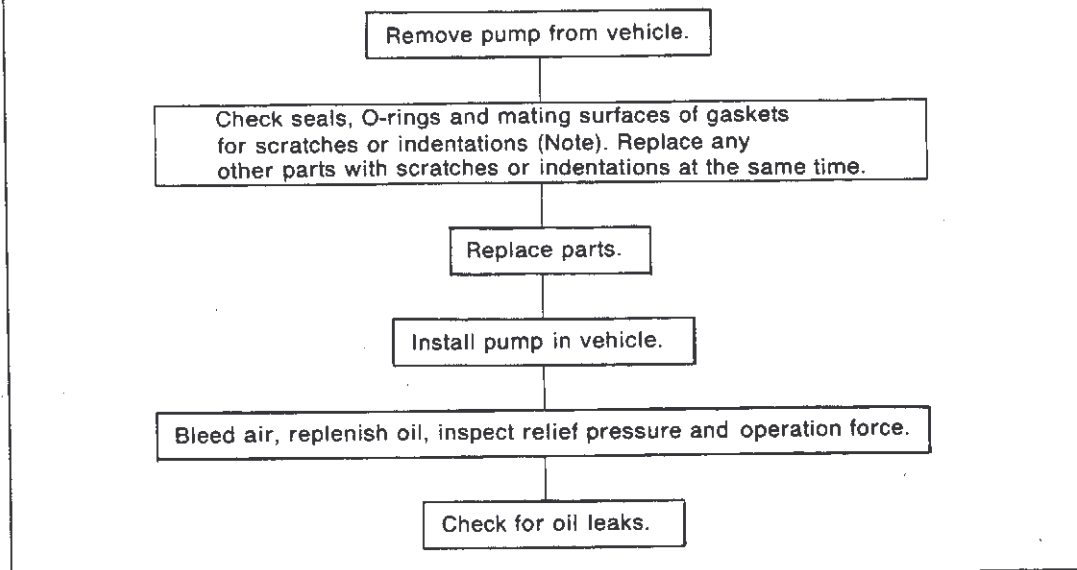

Note: The standard for replacing related parts is if a fingernail scrapes or catches in a scratch.

C11 STEERING

2. On-vehicle Inspection and Adjustment (Cont'd)

(4) Oil leak from part ① (steering gear)

Model PR26SE power steering

(Model PR26SE)

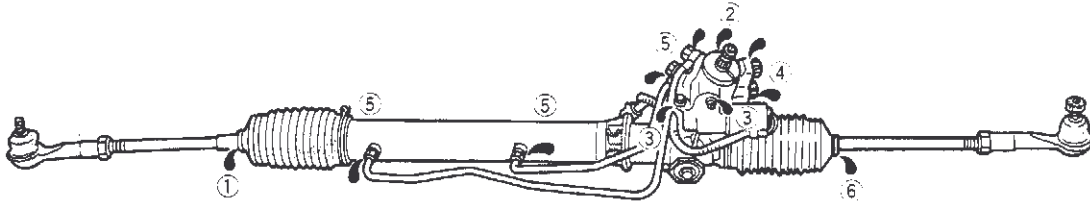

Note: Adjusting screw is included in ⑤.

Note: When leak location is unclear, wash area with white gasoline or solvent and check leak location.

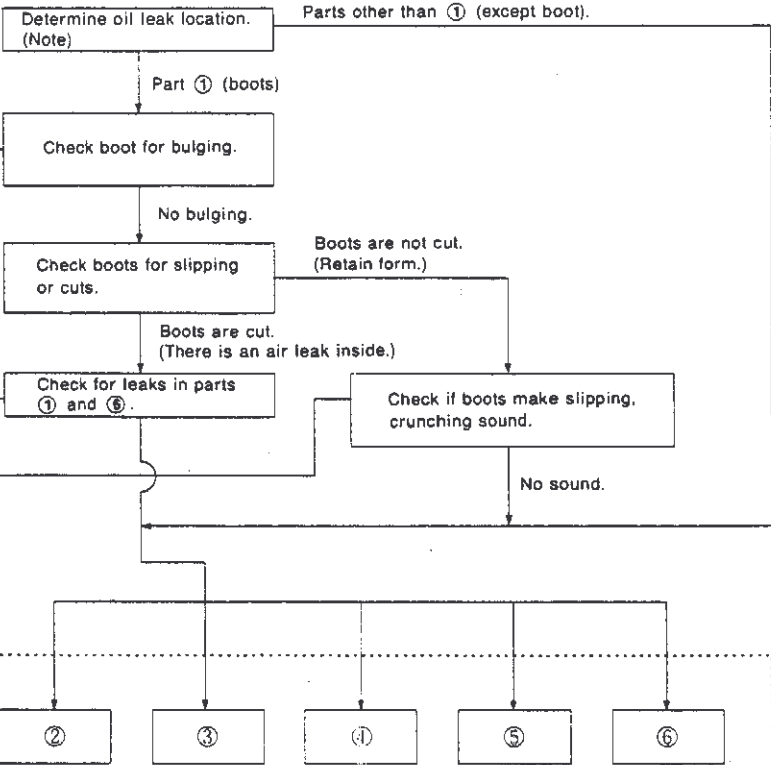

C15-0043E

C11 STEERING

2. On-vehicle Inspection and Adjustment (Cont'd)

Oil leak location	① Dust boot	② Upper rear housing	③ Rear housing and gear housing mating surfaces	④ Power steering high- and low-pressure and HICAS low-pressure side connections.	⑤ Cylinder tube connections (rear housing side and gear housing side)	⑥ Dust boot
Installation check items on vehicle	—	—	Bolt tightening torque 20 - 24 N·m (2.0 - 2.4 kg-m, 14 - 17 ft-lb)	Pipe tightening torque Power steering side PR26SE High-pressure side: 30 - 35 N·m (3.1 - 3.6 kg-m, 22 - 26 ft-lb) Low-pressure side: 36 - 40 N·m (3.7 - 4.1 kg-m, 27 - 30 ft-lb) HICAS High-pressure side: 29 - 39 N·m (3.0 - 4.0 kg-m, 22 - 29 ft-lb) Low-pressure side: 29 - 39 N·m (3.0 - 4.0 kg-m, 22 - 29 ft-lb)	Cylinder tube tightening torque: 29 - 39 N·m (3.0 - 4.0 kg-m, 22 - 29 ft-lb) Cylinder tube union bolt tightening torque: 20 - 29 N·m (2.0 - 3.0 kg-m, 14 - 22 ft-lb)	—
Preparation description (replacement parts)	<ul style="list-style-type: none"> ● Rack oil seal (Note 1) ● O-ring (cylinder end assembly) 	Gear housing assembly	—	<ul style="list-style-type: none"> ● Pipes (tube sheet in port) 	—	Gear housing assembly
Related parts requiring replacement	Gear housing assembly	—	—	Gear housing assembly	—	—

Preparation procedures

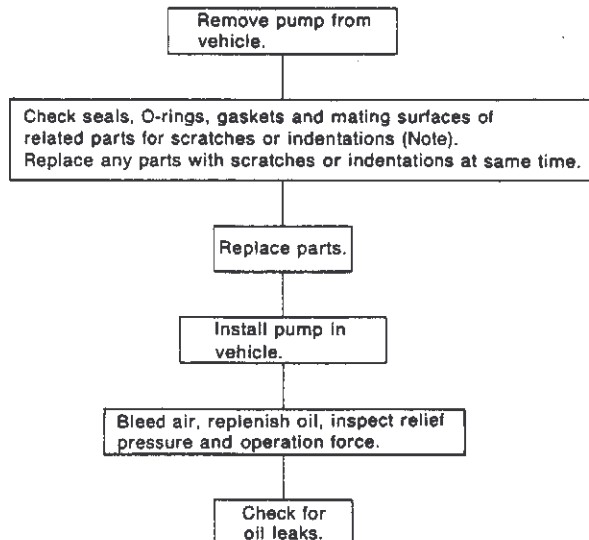

Note:

- (1) Make sure there is no peeling around rack oil seal. If there is peeling, also replace gear housing.
- (2) The standard for replacing related parts is if a fingernail scrapes or catches in a scratch.

C11 STEERING

2. On-vehicle Inspection and Adjustment (Cont'd)

2-11 STEERING FORCE INSPECTION

(1) Precautions before inspection

- ① Are the tire air pressure and size correct? Is the steering wheel a genuine part?
- ② Is the wheel offset correct? (Check if wheel spacers are present.)
- ③ Is wheel alignment correct?
- ④ Has the suspension been modified? Has the vehicle weight been increased?

(2) Problem classification

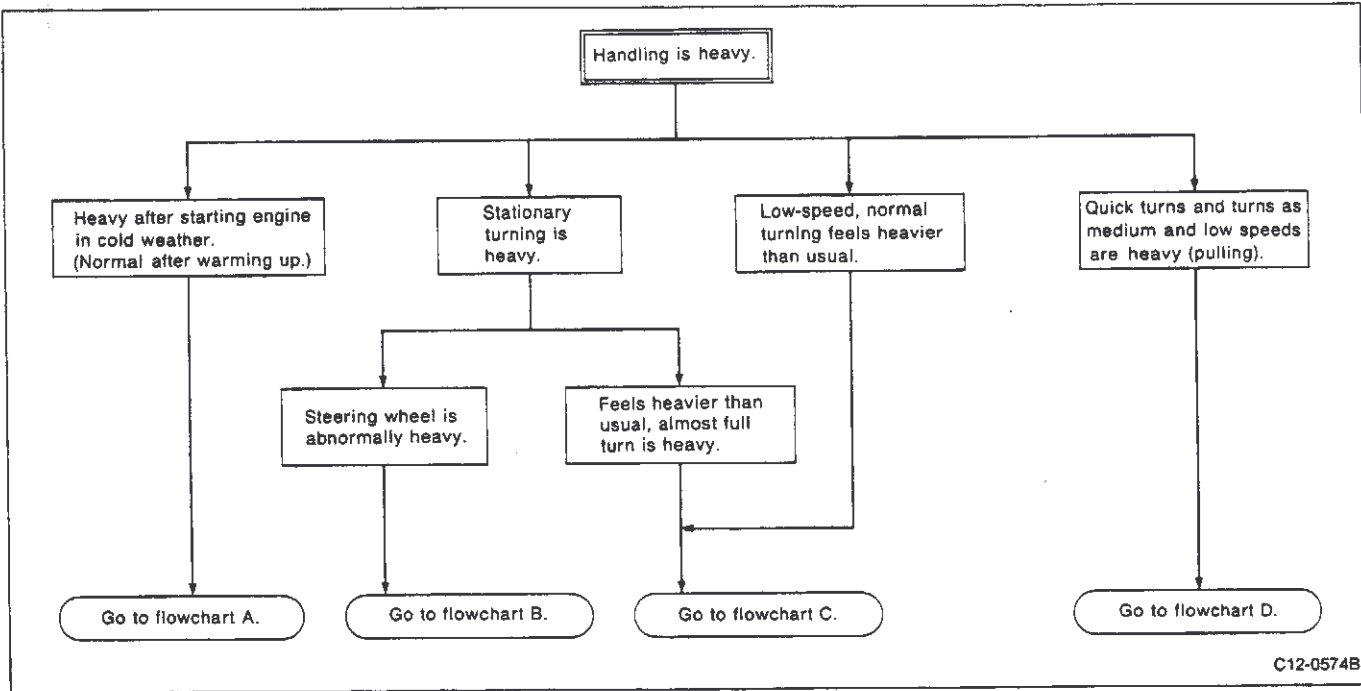

(3) Damage diagnosis flowchart (entire vehicle)

① Flowchart A

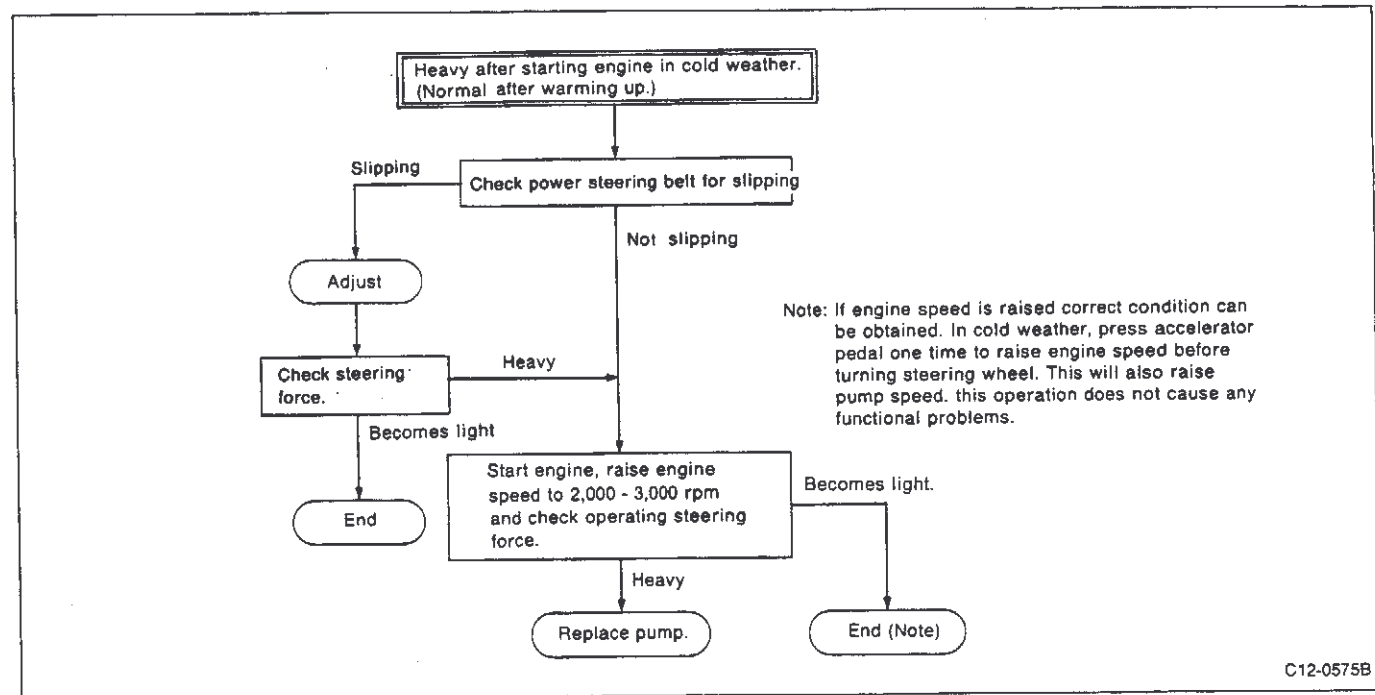

C11 STEERING

2. On-vehicle Inspection and Adjustment (Cont'd)

② Flowchart B

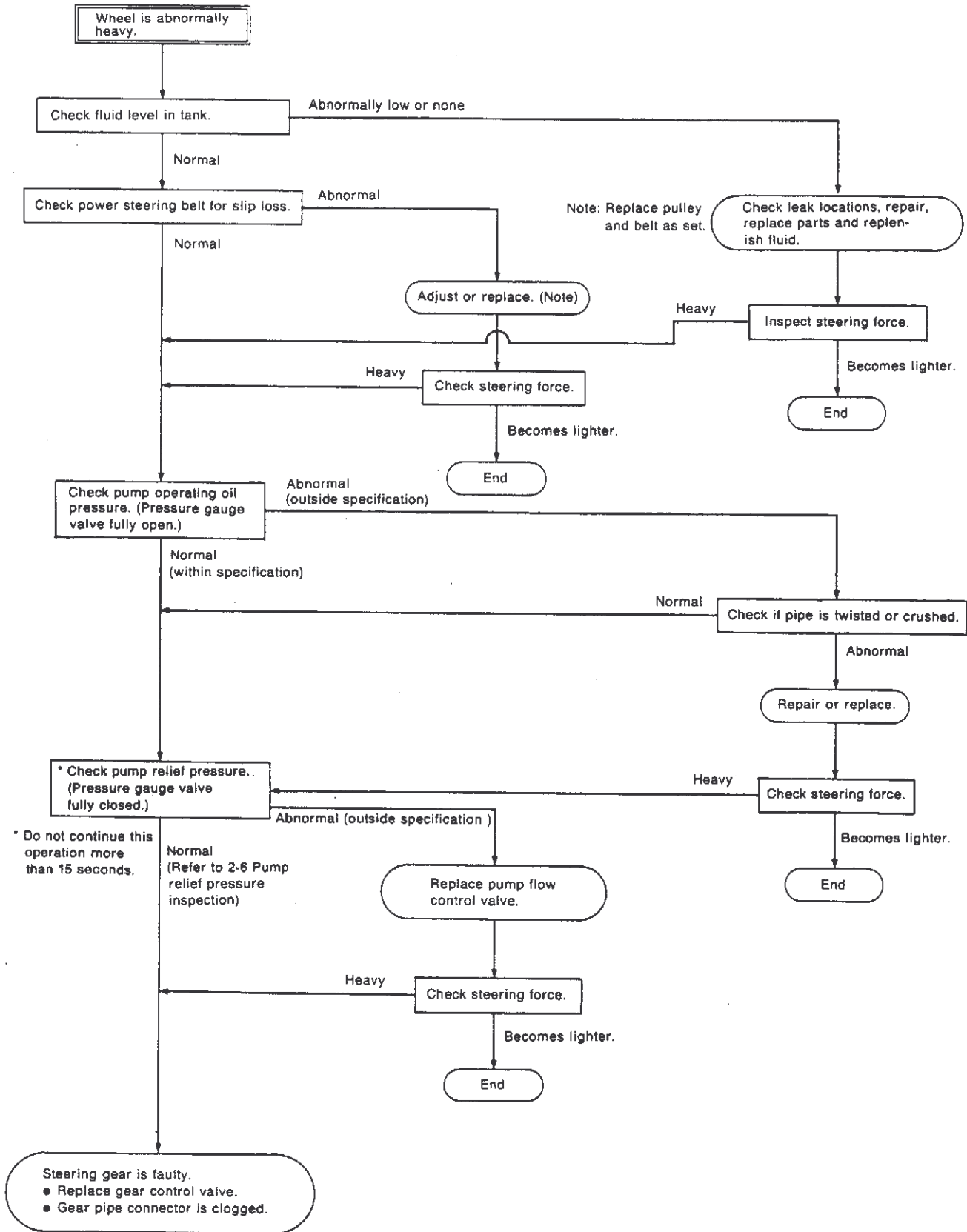

C11 STEERING

2. On-vehicle Inspection and Adjustment (Cont'd)

③ Flowchart C

Verification items

- Is the tire air pressure and size correct? Is the steering wheel a genuine part?
- Is the wheel offset correct? (Check if wheel spacers are present.)
- Is wheel alignment correct?
- Has the suspension been modified? Has the vehicle weight been increased?
- Steering column wheel cover and rubber coupling do not grip.

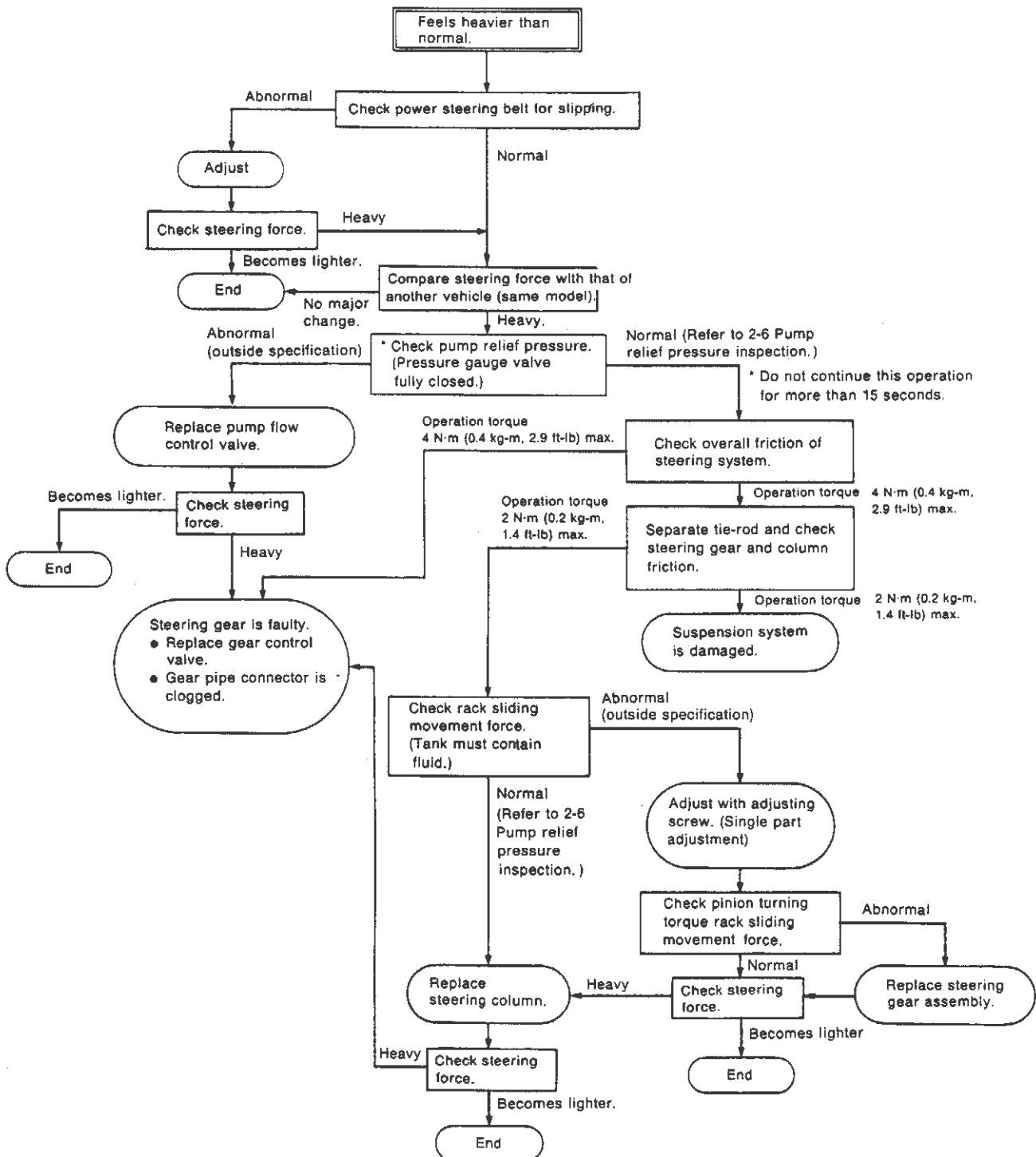

C11 STEERING

2. On-vehicle Inspection and Adjustment (Cont'd)

④ Flowchart D

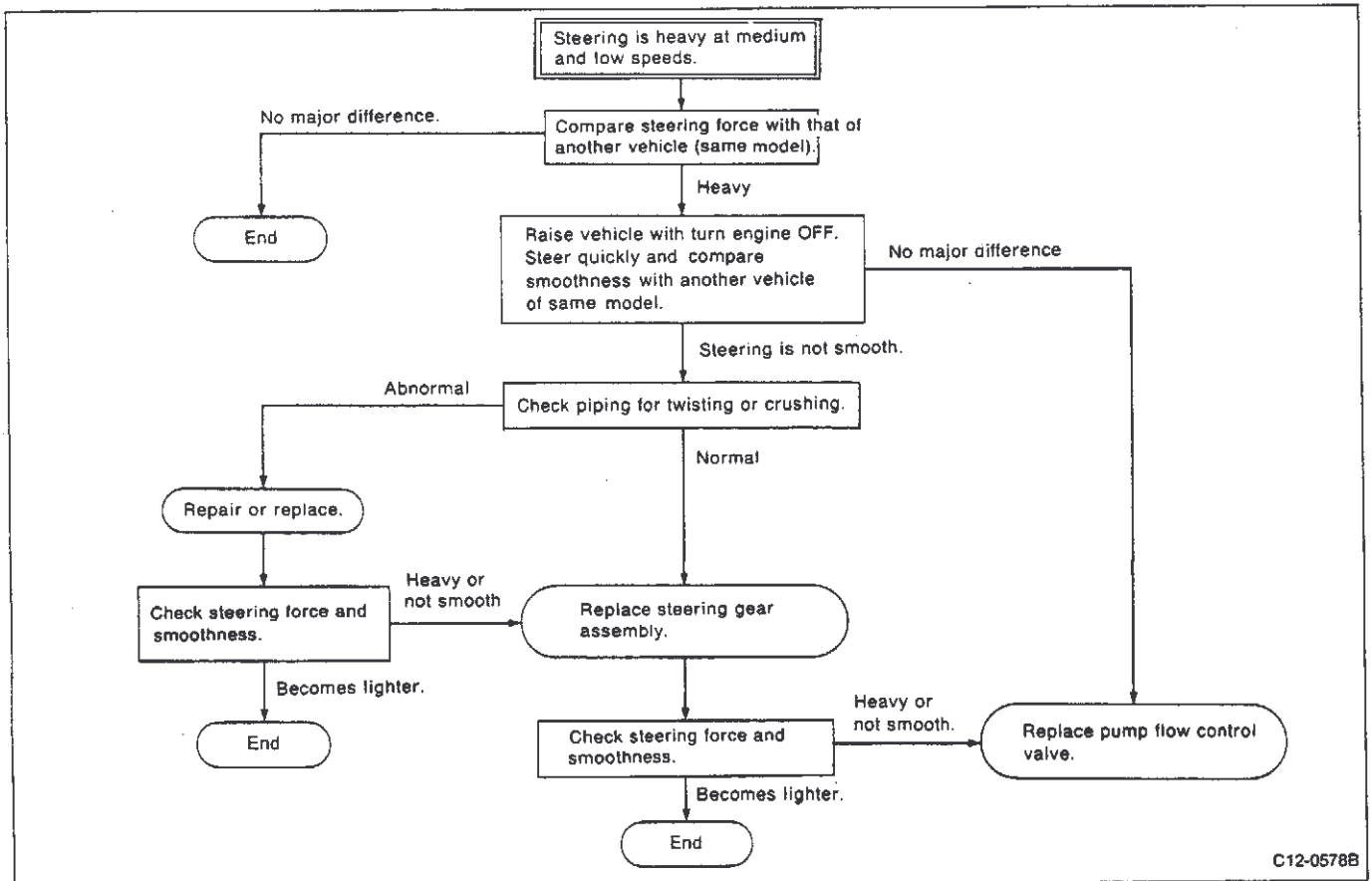

(4) Flowchart (Electrical control power steering)

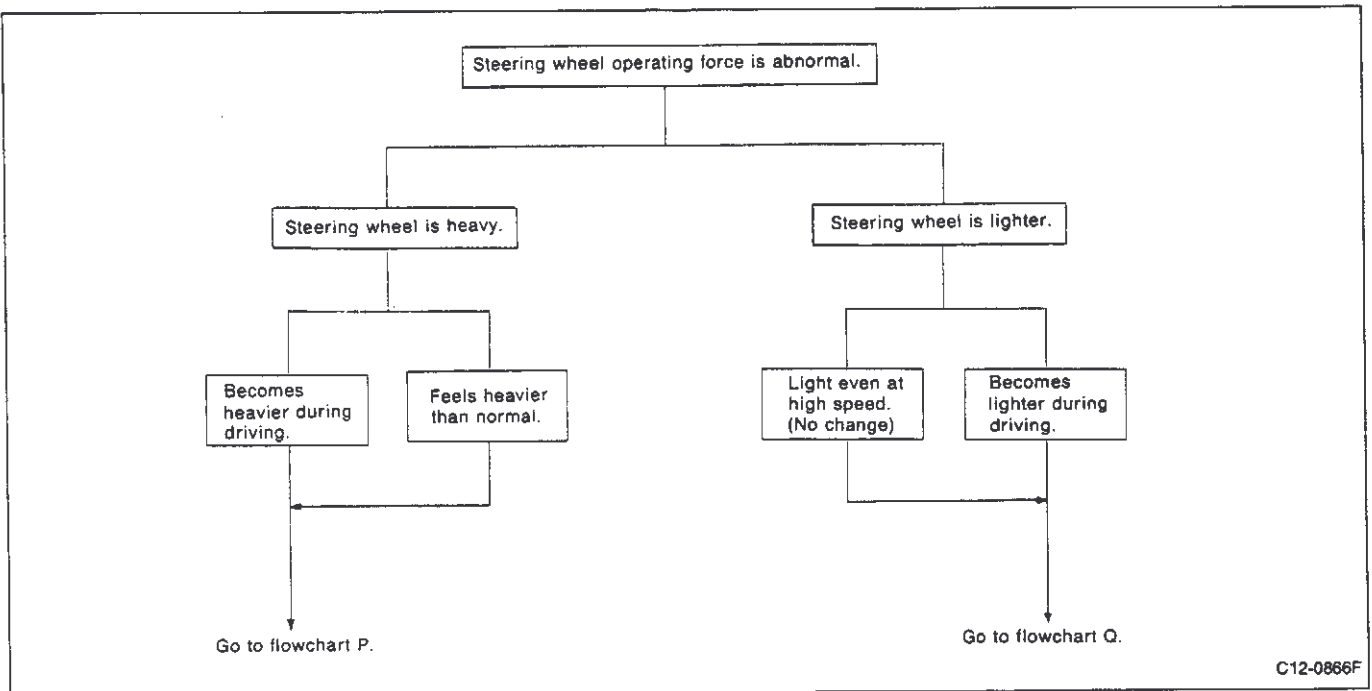

C11 STEERING

2. On-vehicle Inspection and Adjustment (Cont'd)

① Flowchart P

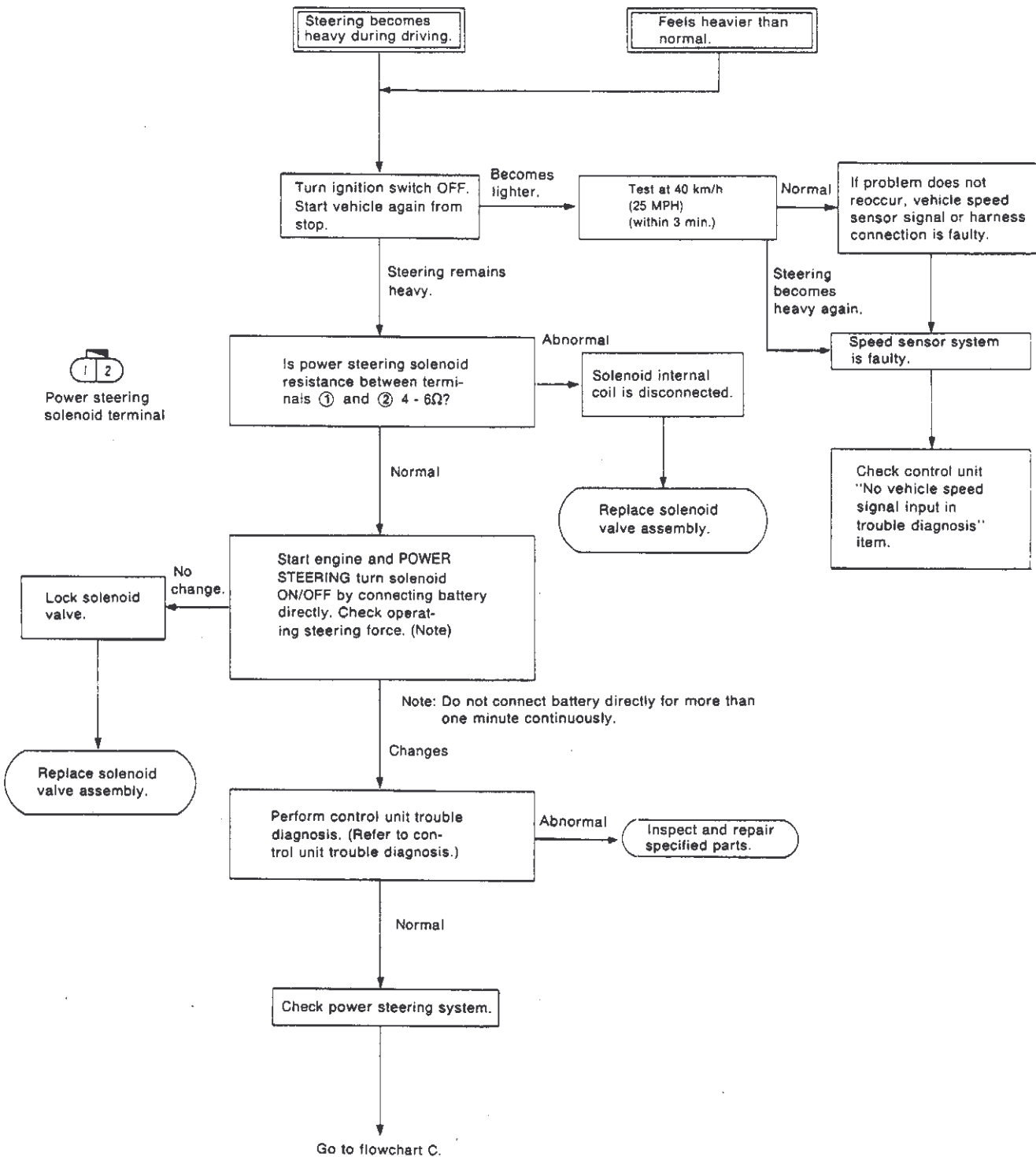

C11 STEERING

2. On-vehicle Inspection and Adjustment (Cont'd)

② Flowchart Q

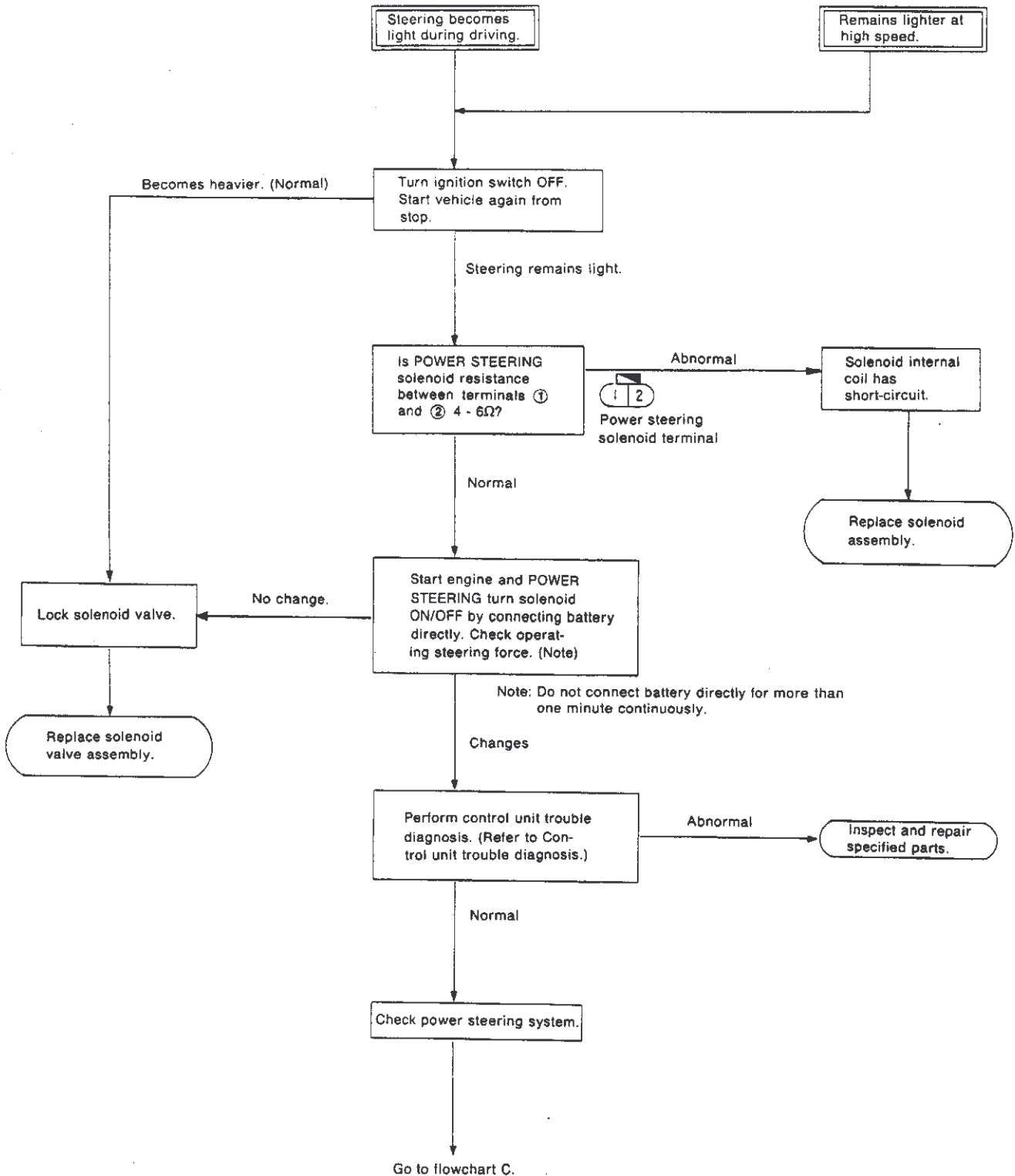

C11 STEERING

3. Control Unit Trouble Diagnosis

3-1 CIRCUIT DIAGRAM (Refer to Super HICAS system circuit diagram.)

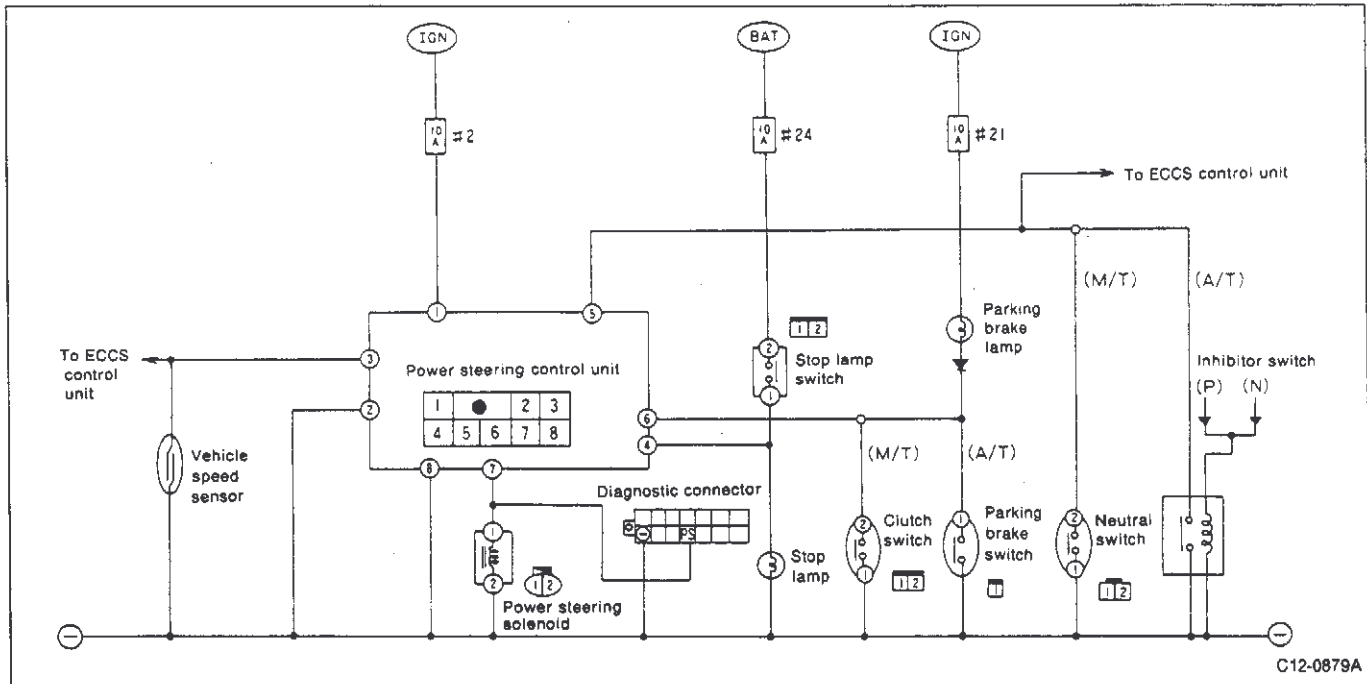

3-2 DAMAGE DIAGNOSIS

Precautions

Before starting to diagnose the power steering system ensure that:

<Vehicle stopped >

1. Power steering components (gears, oil pump, pipes, etc.) are free from leakage and that oil level is correct.
2. Tires are inflated to specified pressure and are of specified size, and that steering wheel is a genuine part.
3. Wheel size is adjusted properly.
4. Suspension utilizes the original design and is free of modifications which increase vehicle weight.

<Vehicle in operation >

1. Understand the trouble symptoms. (5W1H)
2. Engine is operating properly.

C11 STEERING

3. Control Unit Trouble Diagnosis (Cont'd)

(1) Steering is heavy during stationary turning.

① Preliminary knowledge helpful in conducting diagnoses

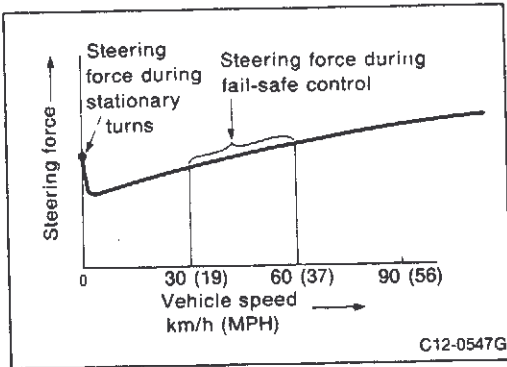

The power steering system is a twin-orifice type, which uses a vehicle-speed sensing, electronic control design. Valve sensitivity is controlled in response to vehicle speed to achieve optimum steering effort. When a vehicle-speed signal is not input to the power steering control unit for more than approximately 10 seconds, a fail-safe system activates to maintain the steering effort at a level similar to that experienced during operation at a vehicle speed of 30 to 60 km/h (19 to 37 MPH).

Consequently, if a foot-brake signal, parking brake or transmission position signal, or neutral in signal a vehicle equipped with manual transmission are not input to the POWER STEERING control unit, the steering system is maintained in a "fail-safe" control state. When this happens, a symptom referred to a "heavy steering during stationary turns" sometimes occurs.

Note: Normal operation refers to a driving condition in which the foot brake pedal and parking brake lever are released, and the shift lever is any position other than neutral or clutch pedal is released in a vehicle equipped with manual transmission.

C11 STEERING

3. Control Unit Trouble Diagnosis (Cont'd)

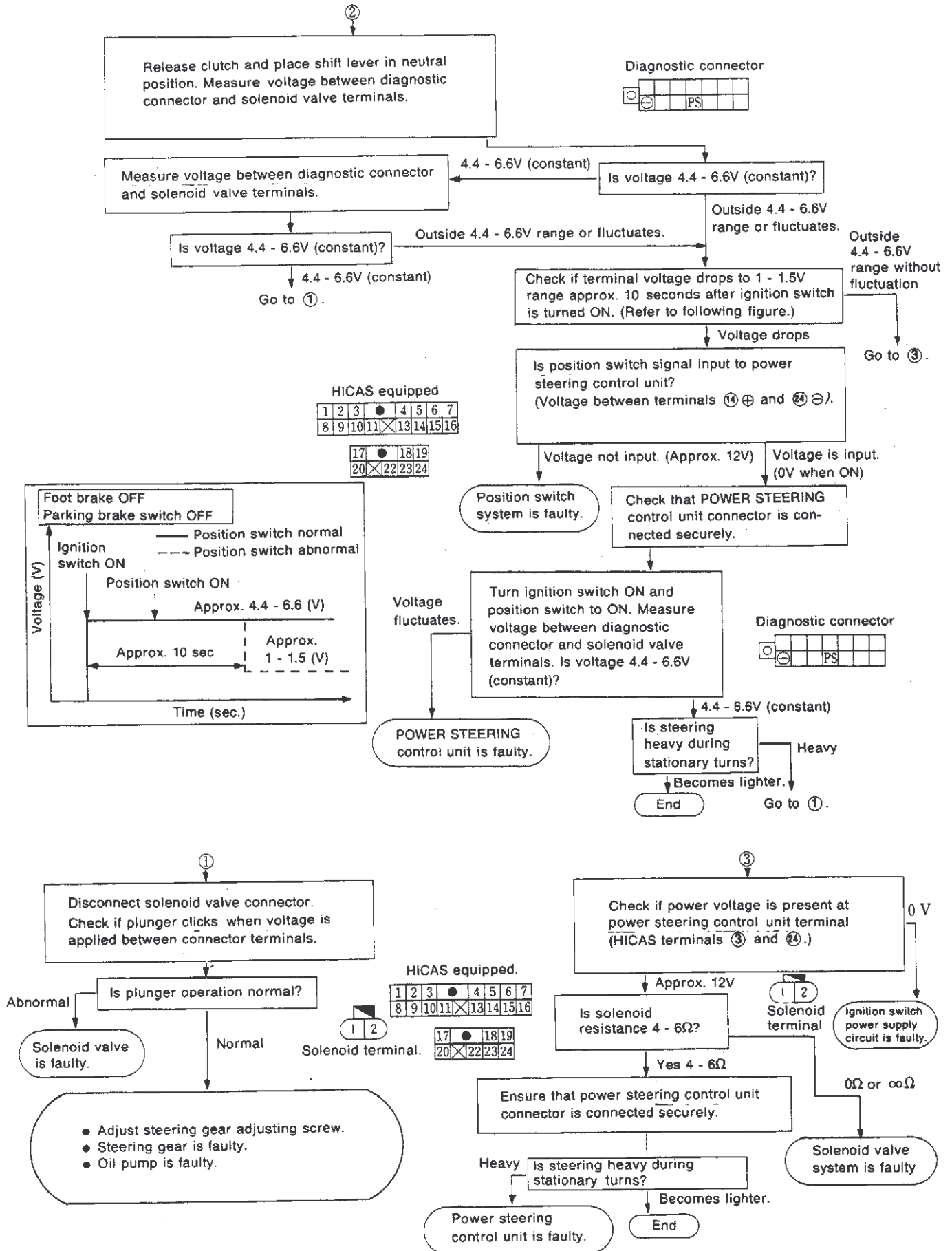

C11 STEERING

3. Control Unit Trouble Diagnosis (Cont'd)

(2) Light steering operation during high-speed driving

① Flowchart

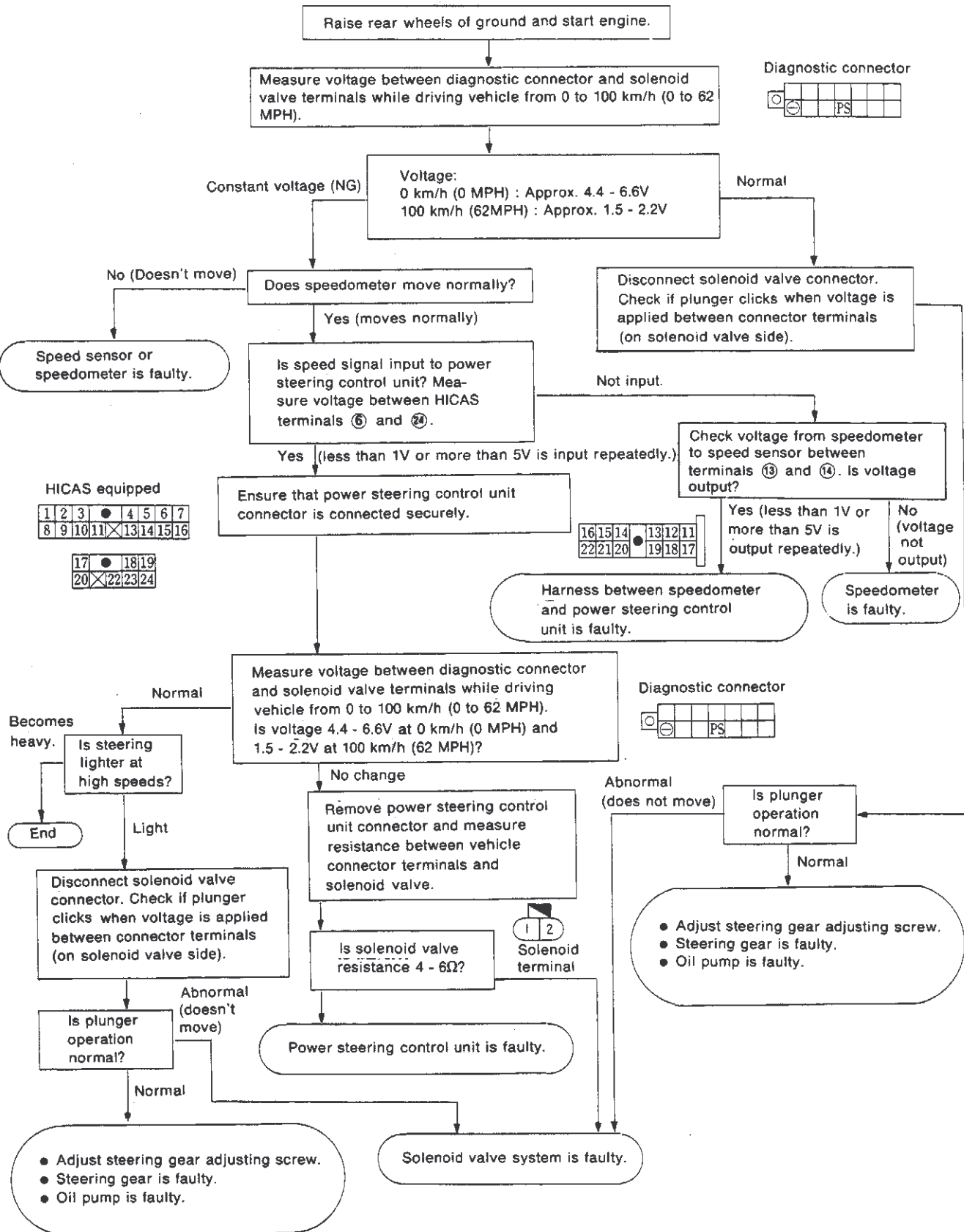

C11 STEERING

4. Removal and Installation, Assembly and Disassembly

4-1 STEERING WHEEL AND STEERING COLUMN ASSEMBLY REMOVAL AND INSTALLATION

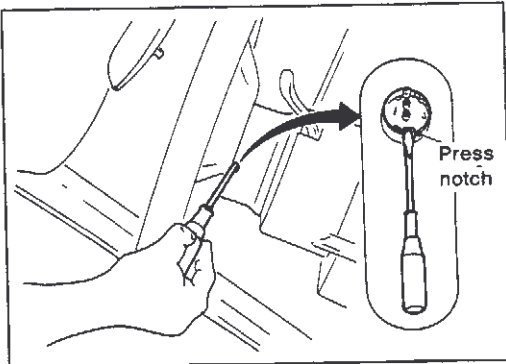
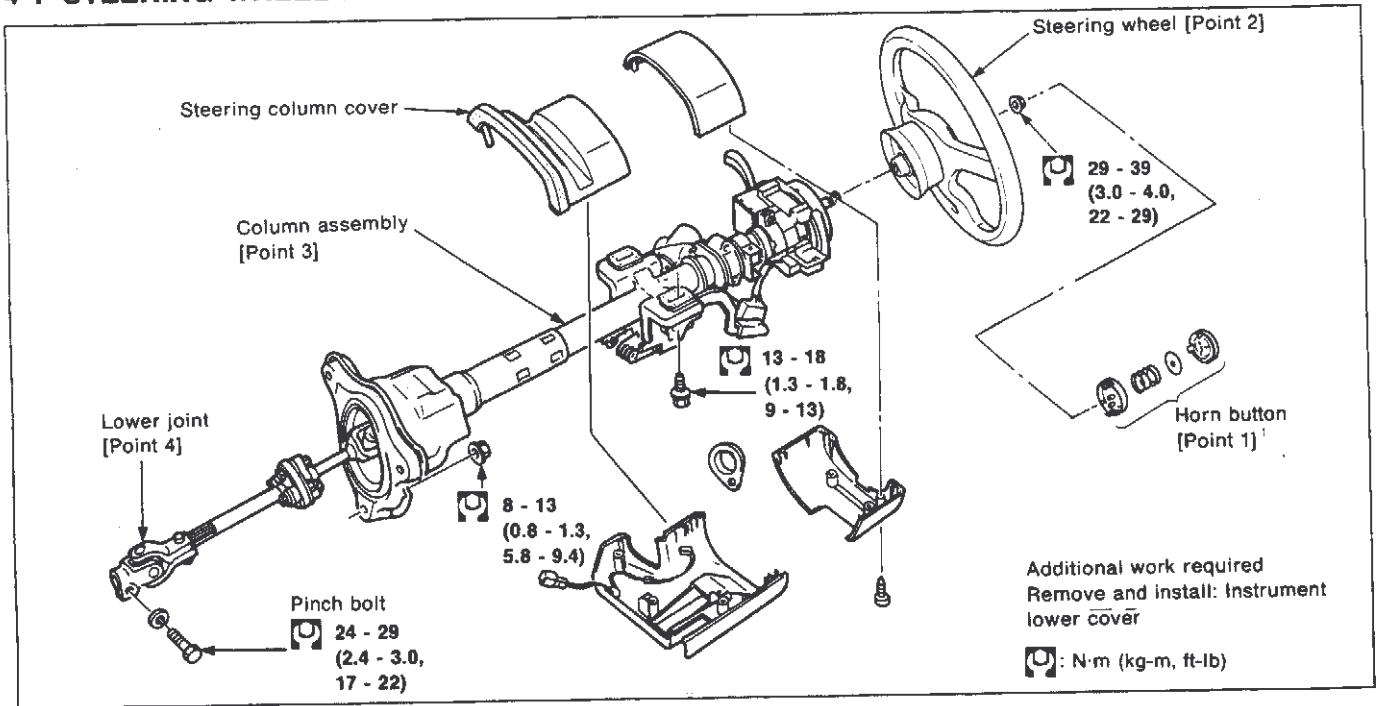

[Point 1] Horn button removal

- Press horn button notch from hole under steering wheel with screwdriver and remove horn button as shown in figure.

CAUTION:

- (1) Pay attention not to scratch steering wheel and horn pad.
- (2) Remove horn without placing unnecessary tension on wiring.

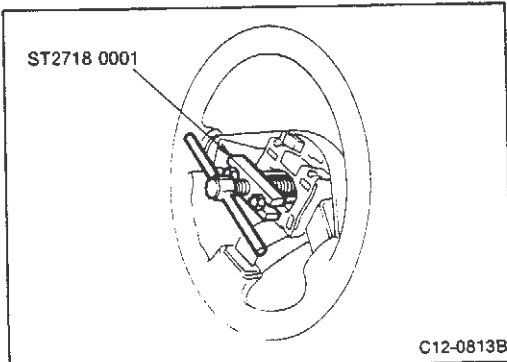

[Point 2] Steering wheel removal and installation

Removal

- Always use steering wheel puller (special service tool) to remove steering wheel.

CAUTION:

Do not tap steering wheel or apply undue stress to steering column shaft (especially in axial direction).

C11 STEERING

4. Removal and Installation, Assembly and Disassembly (Cont'd)

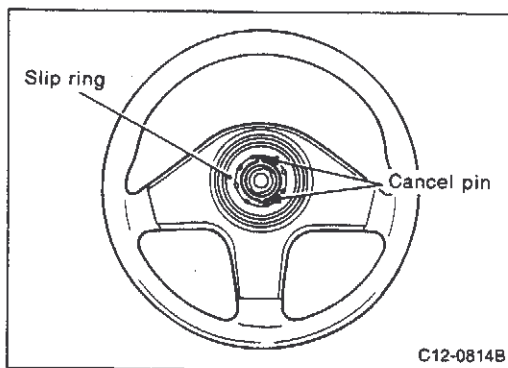

Installation

- When installing steering wheel, apply multi-purpose bod grease (spray type: KRH05-00030) to entire surface of turn signal cancel pin and horn contact slip ring.

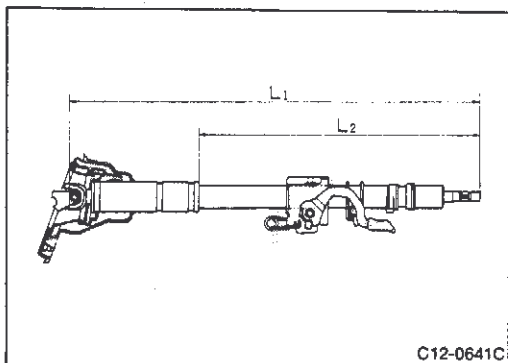

[Point 3] Column standard dimension measurement

- Measure dimension L_1 (standard value). Replace column assembly if measurement is outside specification range.
- Refer to the following specification values for vehicle equipped with telescopic wheels.

Description		Telescopic wheel
L_1	mm (in)	685.5 - 720.5 (26.99 - 28.37)
L_2	mm (in)	423.4 - 458.4 (16.67 - 18.05)

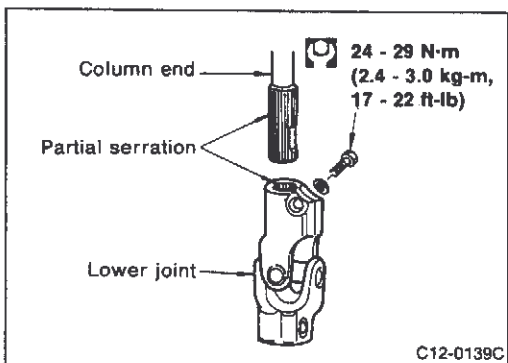

[Point 4] Lower joint assembly

- Align position where serration is incomplete (Note) in lower joint and steering column and install shaft.

Note: Lower joint has a projecting portion in serration. Steering column fits into serration indentation.

- Align pinch bolt to shaft notch part on gear side and column side correctly and insert securely. After fingertightening tighten to specified torque.

[Point 5] Installation inspection

- After installing steering column, turn steering wheel to make sure it moves smoothly, without any noise or excess force. Also check that the number of turns from the straight ahead position to left and right locking points are equal. Be sure that the steering wheel is in a neutral position when driving straight ahead.

C11 STEERING

4. Removal and Installation, Assembly and Disassembly (Cont'd)

(2) Assembly and disassembly

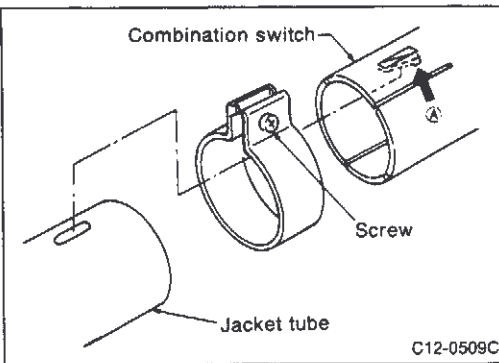
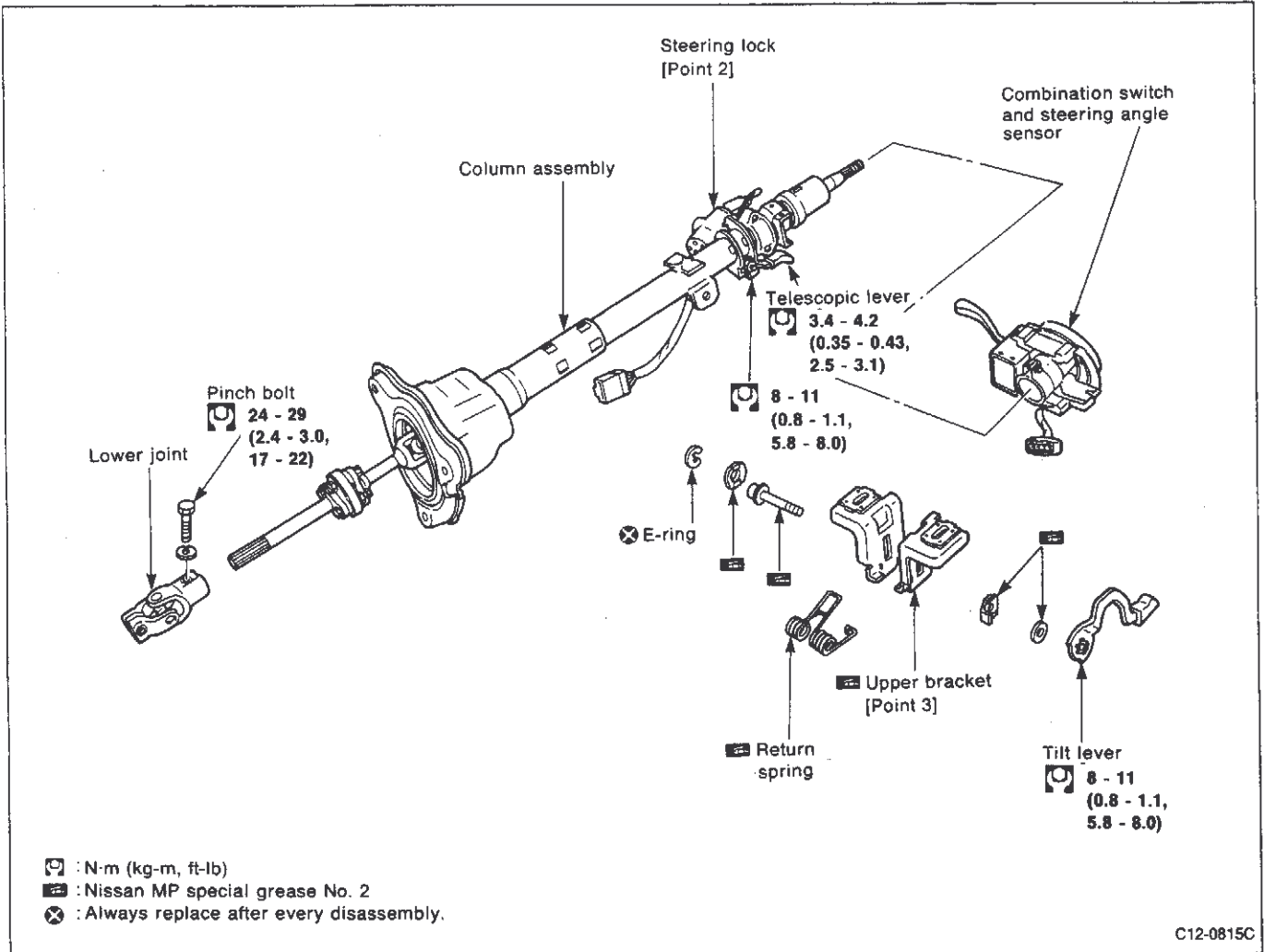

[Point 1] Combination switch removal

- To remove combination switch from jacket tube, first loosen screw. While prying notch **A** on inside of switch with screwdriver, remove switch.

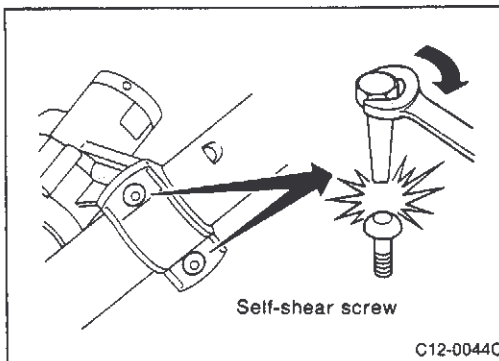

[Point 2] Steering lock installation

- Align positioning boss on steering lock with hole in jacket tube and tap bracket with self-shear screw to secure.
- Tighten self-shear screw and then cut off screw heads.

C11 STEERING

4. Removal and Installation, Assembly and Disassembly (Cont'd)

[Point 3] Upper bracket inspection

- Upper bracket and sliding block are set in plastic molding as shown in figure.
- If sliding block is falling off, replace upper bracket assembly.

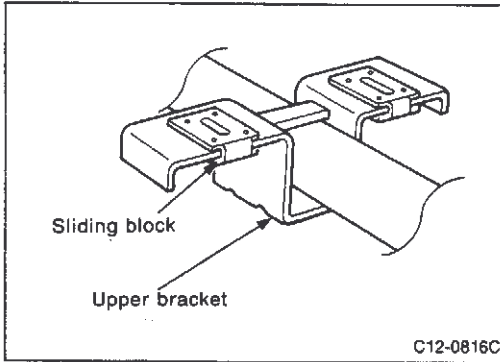

4-2 STEERING GEAR AND LINKAGE

(1) Removal and installation

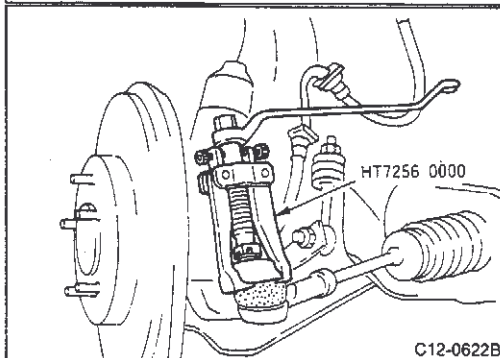
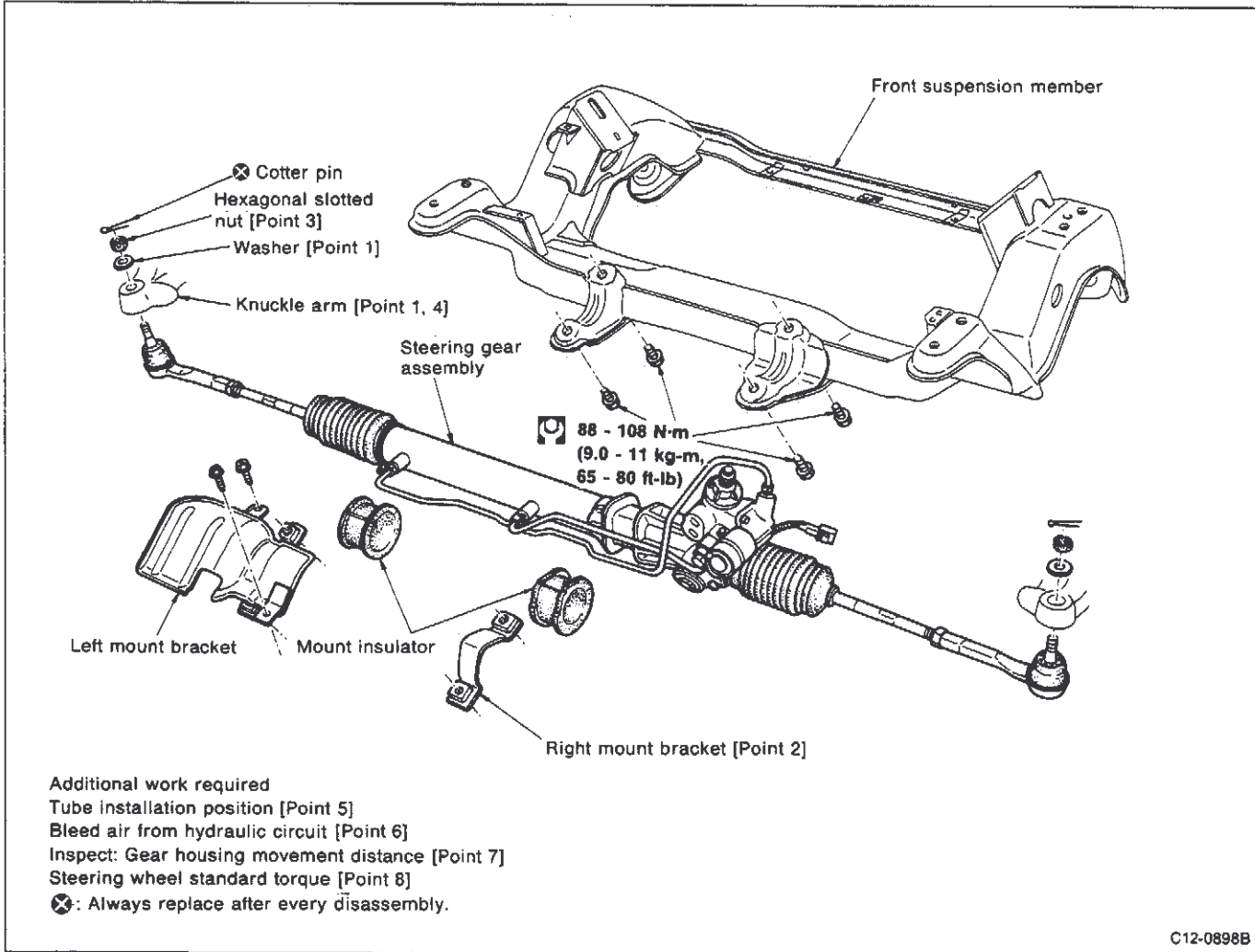

[Point 1] Knuckle arm separation

- Use Pitman arm puller (commercial service tool) to remove knuckle arm.

CAUTION:

Do not scratch dust boot of tie-rod ball joint.

C11 STEERING

4. Removal and Installation, Assembly and Disassembly (Cont'd)

[Point 2] Gear mount bracket and mount insulator installation

- Perform alignment securely since right side bracket and insulator have projection as shown in figure.
- Coat mount bolt with machine oil or equivalent.
- To install bracket, initially tighten nuts to 78 N·m (8.0 kg·m, 58 ft·lb) and then tighten to specified torque.

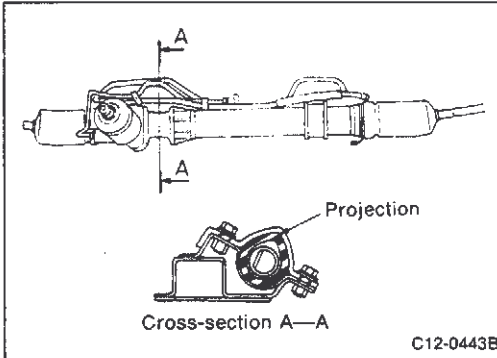

[Point 3] Hexagonal slotted nut tightening

- Tighten nut to specified torque [29 to 39 N·m (3.0 to 4.0 kg·m, 22 to 29 ft·lb)]. Then tighten further to align nut groove with first pin hole so cotter pin can be installed. Tightening torque must not exceed 49 N·m (5.0 kg·m, 36 ft·lb).
- After tightening, check that knuckle arm and ball joint are parallel.

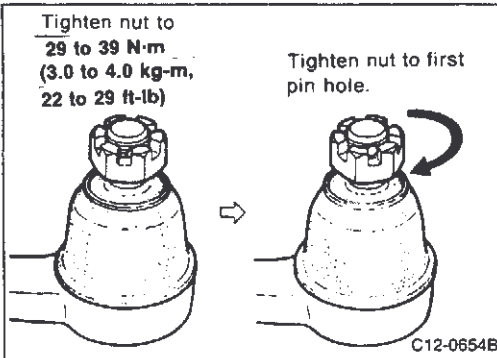

[Point 4] Knuckle arm installation

- When assembling tie-rod ball joint in knuckle arm, insert flat washer before hexagonal slotted nut because knuckle arm is made of aluminum.

CAUTION:

Do not tap knuckle arm to assemble because it is made of aluminum. Be careful not to scratch knuckle arm during assembly.

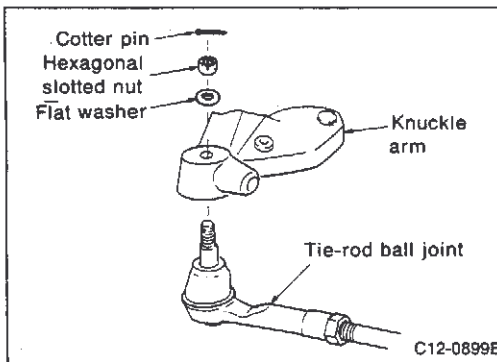

[Point 5] Tube installation position

- Assemble tubes carefully in correct installation positions shown in figure.

- Ⓐ Cylinder pipe (rear housing to gear housing)
- Ⓑ Power steering low-pressure pipe (rear housing to reservoir tank)
- Ⓒ Power steering high-pressure pipe (power steering to rear housing)

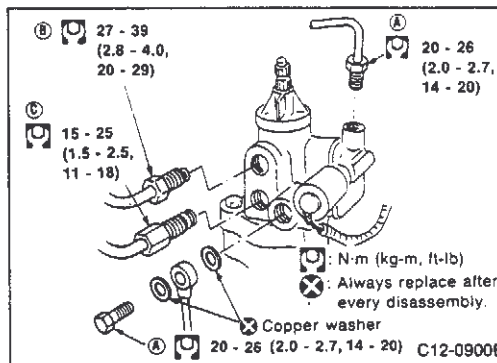

C11 STEERING

4. Removal and Installation, Assembly and Disassembly (Cont'd)

[Point 6] Hydraulic circuit air bleeding

- Perform the procedures described on the left to bleed the air from the hydraulic system.
- The presence of any of the following conditions indicate that air bleeding is not completed. Bleed the system again

- ① Air bubbles are formed in the reservoir tank.
- ② The pump makes a sound like bouncing gravel.
- ③ The pump makes loud growling noises.

Note: The sound of fluid flow from gear valve and pump can be heard during heavy steering during stationary turns or slow steering. This sound does not affect steering performance or durability.

CAUTION:

Perform air bleeding of power steering system before starting engine.

[Point 7] Gear housing movement inspection

- Refer to "2. On-vehicle Inspection and Adjustment".

[Point 8] Steering wheel standard torque inspection

- Refer to "2. On-vehicle Inspection and Adjustment".

(2) Assembly and disassembly precaution

- Secure mounting flange in vice (use copper plates) to assemble and disassemble steering gear.
- Wash dirt on steering gear off with white gasoline or solvent. Be careful not to get the white gasoline or solvent on the ports, harness or connectors for outlet and return.
- Do not reuse O-ring, oil seal (universal joint packing) or copper washer. Always replace with new parts after every disassembly.
- If inner surface of rear housing assembly or gear housing assembly and rack is scratched or damaged, replace gear housing assembly.

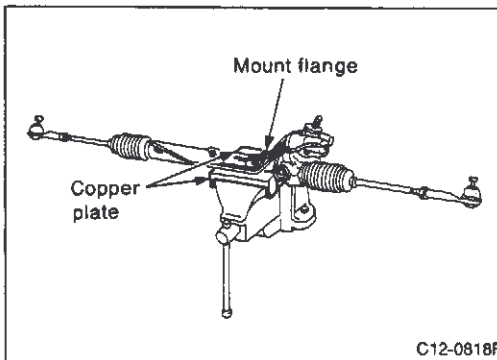
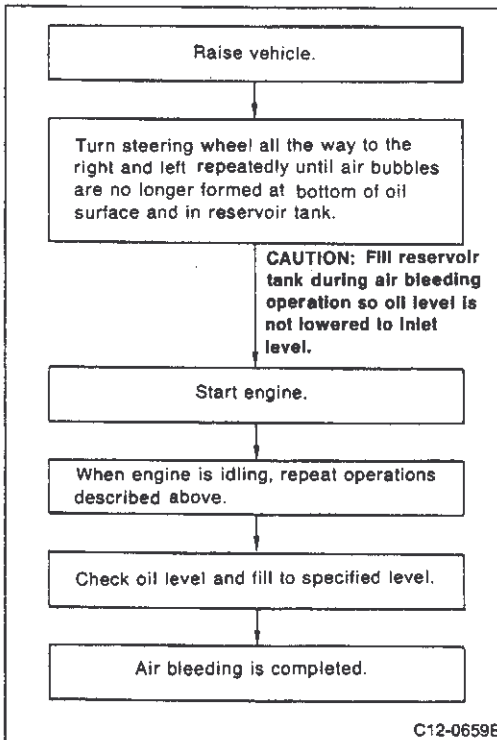

(3) PR26SE power steering gear cross-section

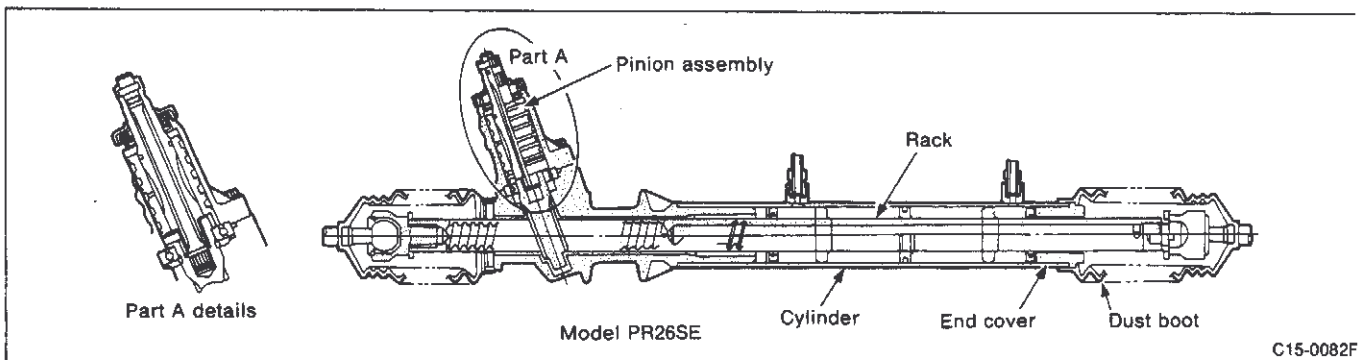

C11 STEERING

4. Removal and Installation, Assembly and Disassembly (Cont'd)

(4) Power steering gear assembly and disassembly (model PR26SE)

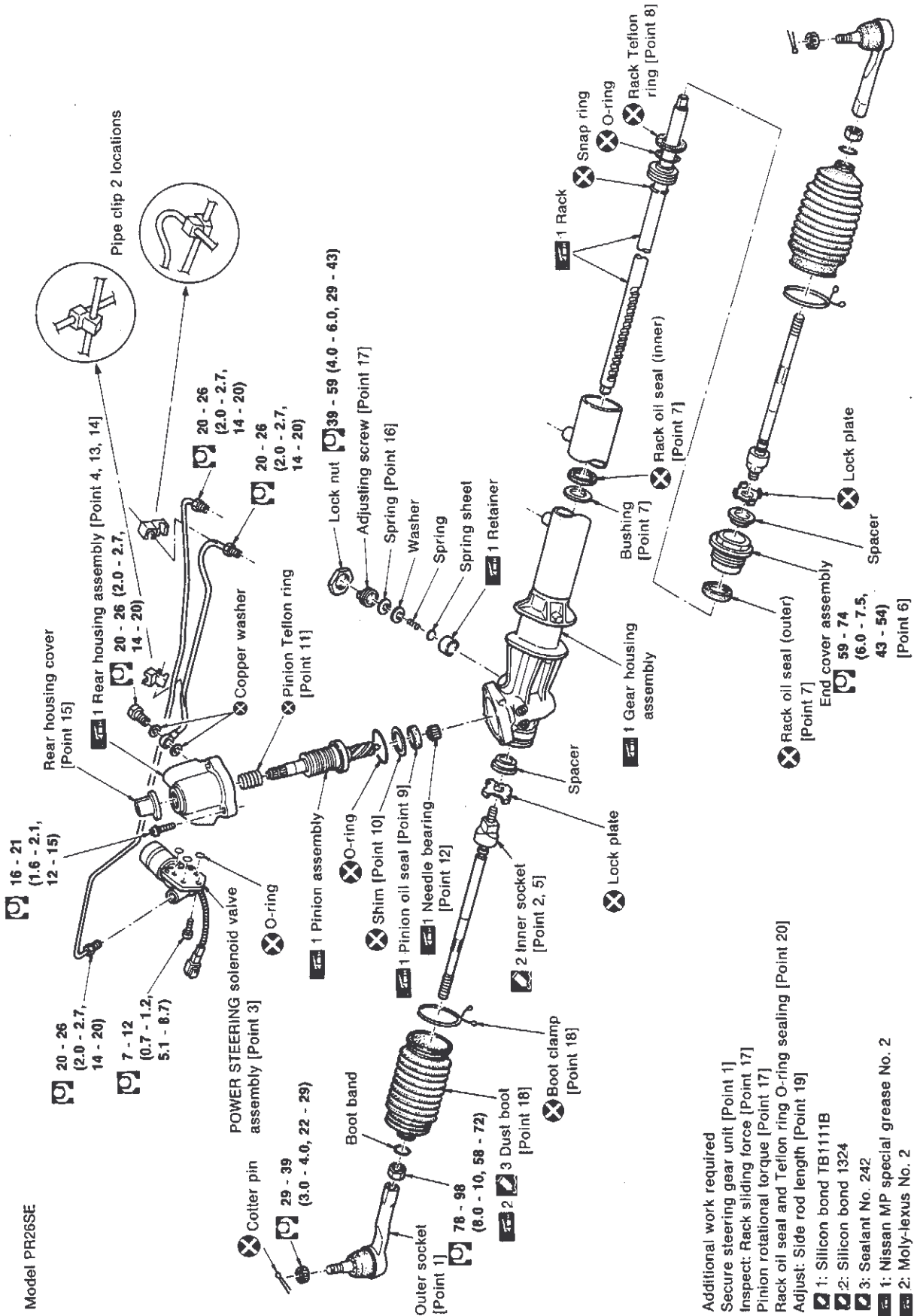

C11 STEERING

4. Removal and Installation, Assembly and Disassembly (Cont'd)

[Point 1] Securing steering gear main unit

- Secure gear housing mount in vise for steering gear assembly and disassembly.

CAUTION:

Insert copper plates in sides of vise to avoid scratching housing.

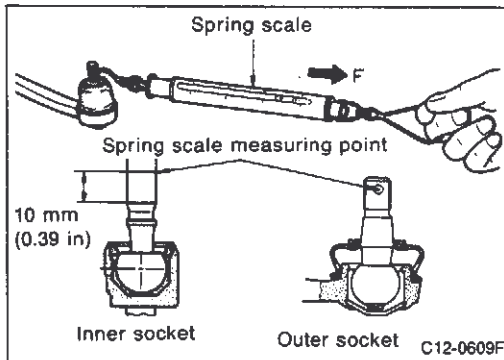

[Point 2] Tie-rod ball joint inspection

Swinging force inspection

- Place spring scale on measurement points indicated in figure. Check that value when ball stand starts moving is within specification indicated below. If value is outside specification range, replace outer socket and inner socket.
- Make sure dust boot of inner and outer socket is not twisted.

Specification values at measurement points shown in figure:

Inner socket

16.7 - 147.1 N (1.7 - 15 kg, 3.7 - 33.1 lb)

Outer socket

4.9 - 46.1 N (0.5 - 4.7 kg, 1.1 - 10.4 lb)

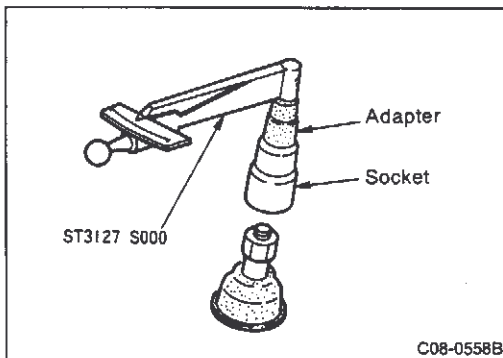

Sliding torque inspection

- Using preload gauge (special service tool), check that torque is within specification limit indicated below. If torque is outside specification, replace outer socket.

Outer socket sliding torque:

0.3 - 2.9 N·m (0.03 - 0.3 kg·m, 0.2 - 2.2 ft-lb)

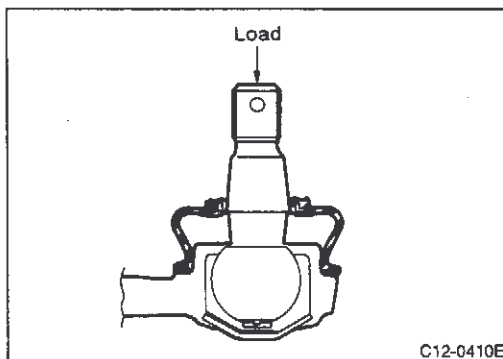

Axial end play inspection

- Apply load of 490 N (50 kg, 110 lb) to axis of ball stud and measure stud play with dial gauge. If play is outside specification indicated below, replace inner and outer socket.

Inner socket:

0 mm (0 in)

Outer socket:

0.5 mm (0.020 in) max.

C11 STEERING

4. Removal and Installation, Assembly and Disassembly (Cont'd)

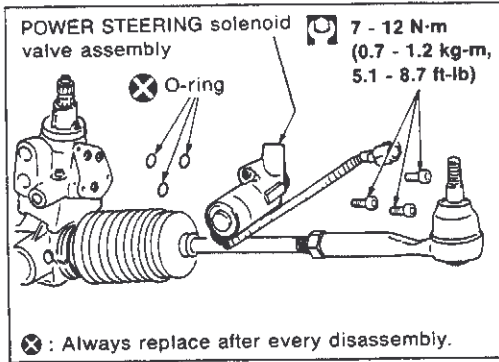

[Point 3] Power steering solenoid valve replacement

- The power steering solenoid valve is an integral unit and cannot be disassembled. If replacement is necessary, replace entire assembly.
- Replace O-rings (3) at assembly. (Non-reusable part)

CAUTION:

- (1) Do not remove the power steering solenoid valve screw because it cannot be disassembled. (It does not adjust the steering force.)
- (2) When replacing assembly, be careful not to allow dirt, debris or foreign matter to adhere to assembly.

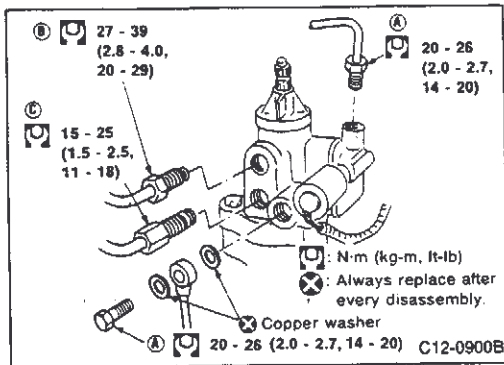

[Point 4] Rear housing pipe installation position

- Assemble pipes carefully in correct installation positions shown in figure.

CAUTION:

Pay close attention because certain parts vary in the 2WD model.

- (A) Cylinder pipe (rear housing to gear housing)
- (B) Power steering low-pressure pipe (rear housing to reservoir tank)
- (C) Power steering high-pressure pipe (power steering to rear housing)

[Point 5] Inner socket assembly and disassembly

Disassembly

- Move the caulking (A 4 locations) of the lock plate (2), loosen socket and separate from rack (4).
- Remove lock plate (2).

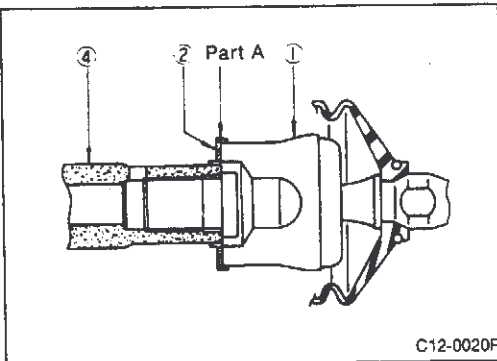

Assembly

- Set lock plate (2) on tie-rod inner socket (1).
- Apply sealant (Three Bond 1324) to threads of inner socket (3). Screw into socket (1) into rack (4) and tighten to specified torque.
- Caulk lock plate at two locations on groove side of rack.

CAUTION:

Wipe off any debris on lock plate so it will not adhere to the boot.

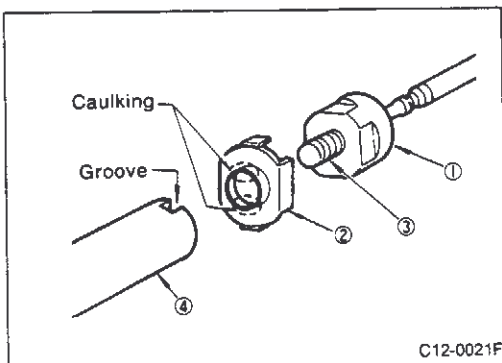

C11 STEERING

4. Removal and Installation, Assembly and Disassembly (Cont'd)

[Point 6] End cover removal and installation

Removal

- Drill staked position of gear housing end with 3.0 mm drill until the staking is eliminated.
- Remove end cover assembly with 42 mm open-end wrench.

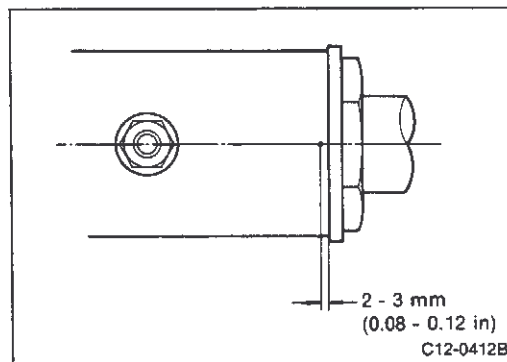
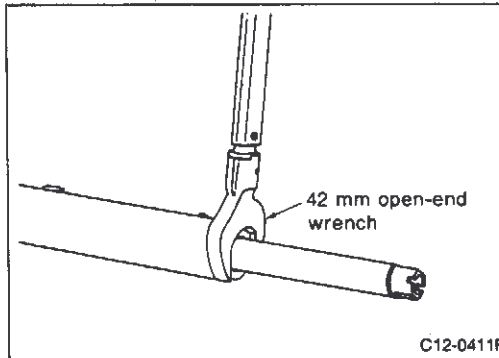
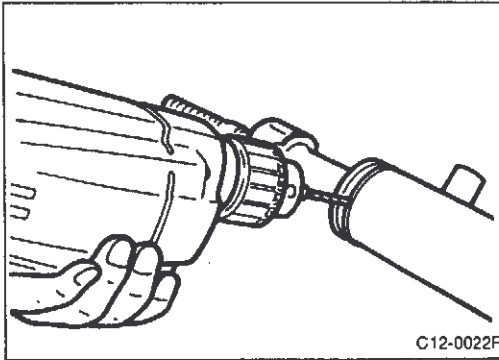

Installation

- Tighten end cover.
Fasten end cover assembly to gear housing with staking to prevent looseness as shown in figure.

[Point 7] Center bushing and rack oil seal removal and installation

Removal

- Turn pinion housing side and remove center bushing and rack oil seal at same time using 29-mm tape-wrapped socket and extension bar [length of 2 pieces is approx. 500 mm (19.69 in)].

CAUTION:

Do not scratch pinion housing or cylinder inner surface.

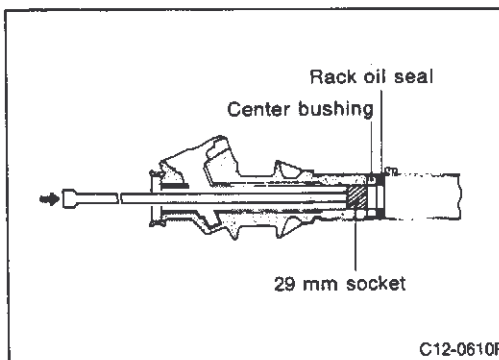

Inner side Installation

- Use rack to install.
- Install center bushing and rack oil seal (inner) separately.

CAUTION:

- (1) Do not scratch rack end surface.
- (2) To prevent scratching rack oil seal (inner), wrap the gear teeth of rack with protective plastic film, size: 70 x 100 mm (2.76 x 3.94 in) and insert oil seal above the wrapped sheet. Pull rack gears together with protective sheet until it passes.

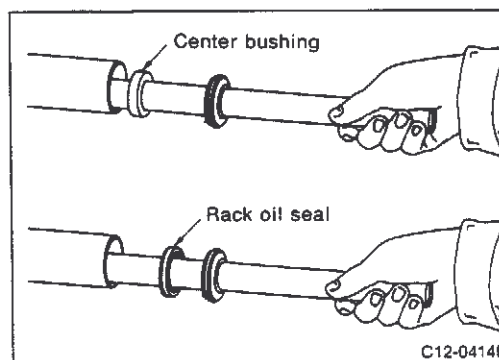

C11 STEERING

4. Removal and Installation, Assembly and Disassembly (Cont'd)

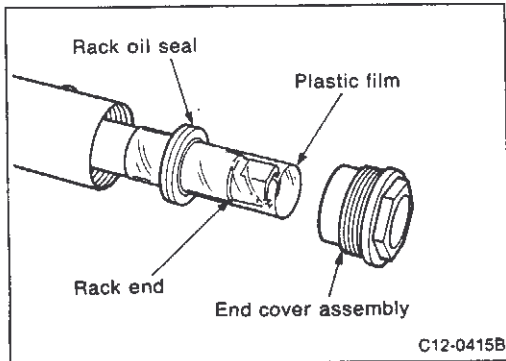
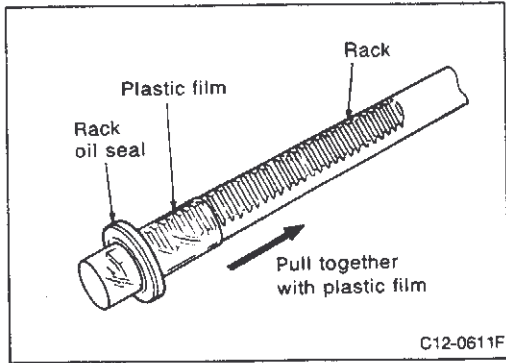

Outer side installation

- Use end cover assembly to install outer side.

CAUTION:

To prevent scratching oil seal, wrap end of rack in a protective plastic film, size: 70 x 100 mm (2.76 x 3.94 in) and insert oil seal. Pull plastic film out together with oil seal.

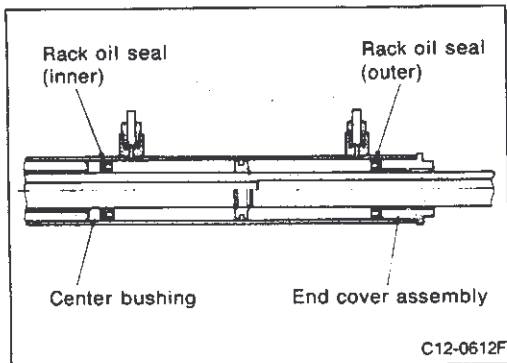

Rack oil seal direction

- Make sure inner and outer side lips of rack oil seal are facing correct direction and install seal.

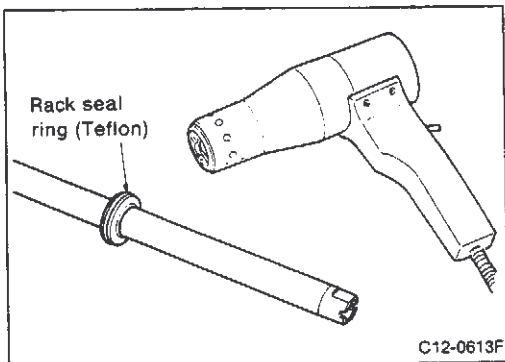

[Point 8] Rack Teflon ring removal and installation

Removal

- Using a heat gun, heat rack seal ring (made of Teflon) to approximately 40°C (104°F).
- Remove Teflon rack seal ring. Be careful not to scratch rack.
- Replace O-ring and Teflon ring with new parts at same time.

Installation

- Using a heat gun, heat rack seal ring (made of Teflon) to approximately 40°C (104°F) and install on rack by hand.

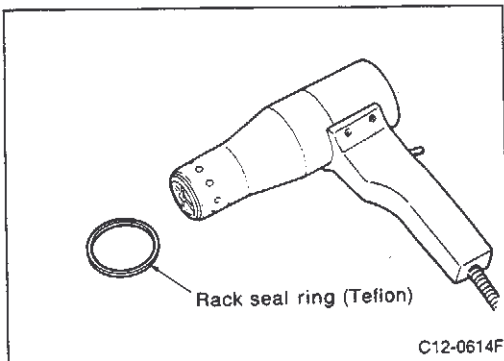

C11 STEERING

4. Removal and Installation, Assembly and Disassembly (Cont'd)

- Use seal ring correction tool (special service tool), compress periphery of rack seal ring (made of Teflon) to position and secure it on rack.

CAUTION:

Always insert the tool from the rack gear side.

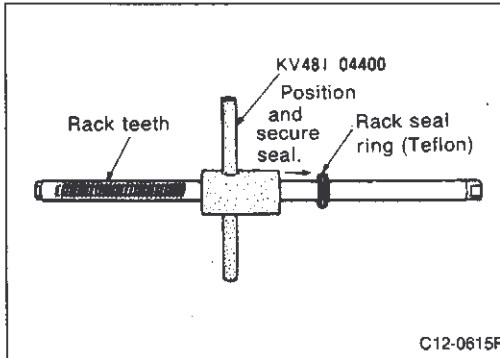

[Point 9] Pinion oil seal removal and installation

Removal

- Using oil seal puller (special service tool), remove oil seal from gear housing.

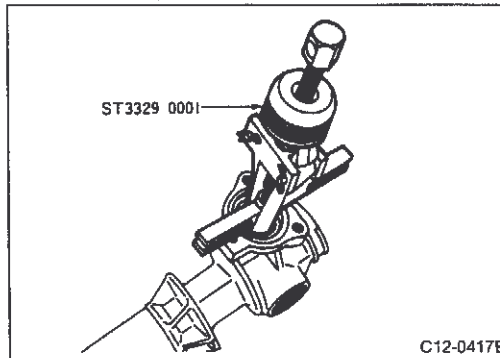

Installation

- Assemble oil seal with spring facing up as shown in figure.

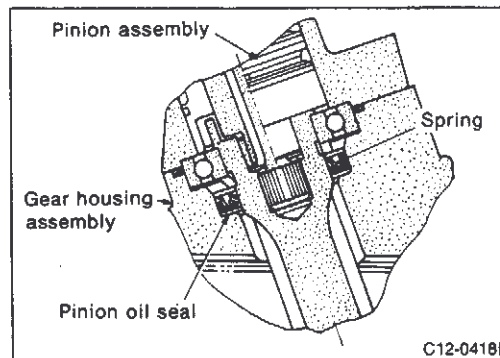

- Use appropriate sized drift and press in oil seal in gear housing. Reference: A 26-mm socket can also be used.

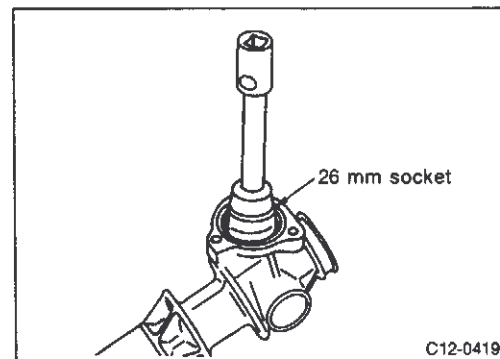

[Point 10] Shim selection

- Assemble unit with the same number of shims that were disassembled, whether replacement of pinion assembly gear housing and rear housing is necessary or not.

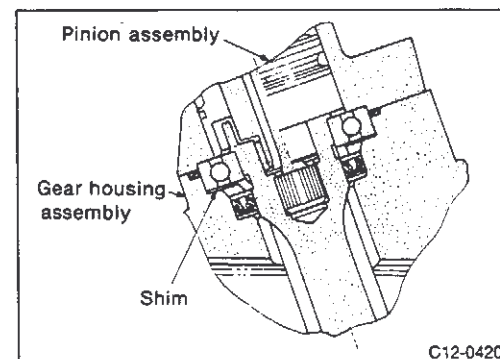

C11 STEERING

4. Removal and Installation, Assembly and Disassembly (Cont'd)

[Point 11] Pinion Teflon ring removal and installation

Removal

- Install Teflon ring on pinion assembly.
Be careful not to damage pinion oil seal.
- Do not reuse Teflon ring.

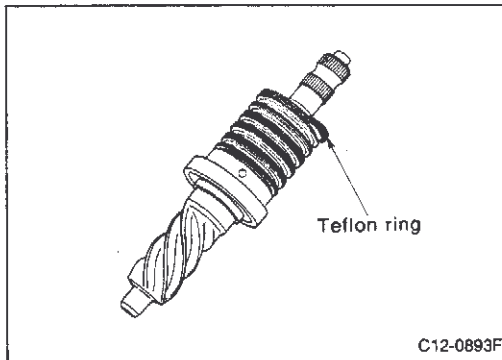

Installation

- Using a heat gun, heat pinion seal ring to approximately 40°C (104°F) before installing it onto pinion gear assembly.
- Make sure pinion seal ring is properly settled in valve groove.

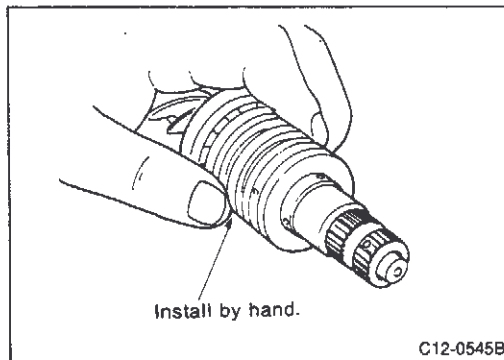

[Point 12] Needle bearing grease coating

- When assembling pinion assembly in gear housing, apply a coat of Nissan MP special grease No. 2 to needle bearing roller and pinion oil seal lip.

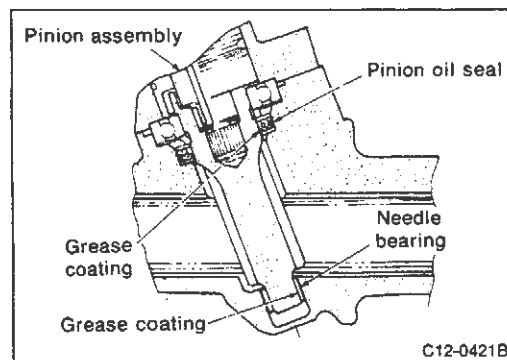

[Point 13] Rear oil seal grease coating

- Apply coat of Nissan MP special grease No. 2 to rear oil seal lip before assembling rear housing as shown in figure.

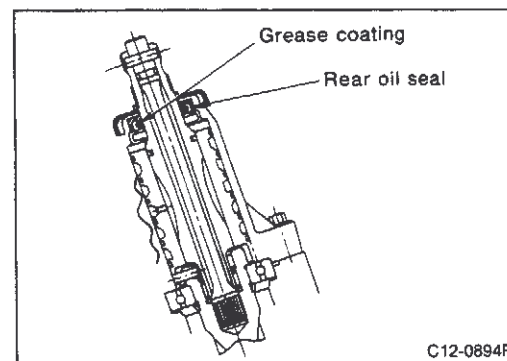

[Point 14] Rear housing assembly installation

- Protect rear oil seal from damage by serration part of pinion assembly by wrapping it assembly serration in a protective plastic film, 50 x 70 mm (1.97 x 2.76 in)].

CAUTION:

If protective film is wrapped on bearing insertion surface the housing cannot be assembled.

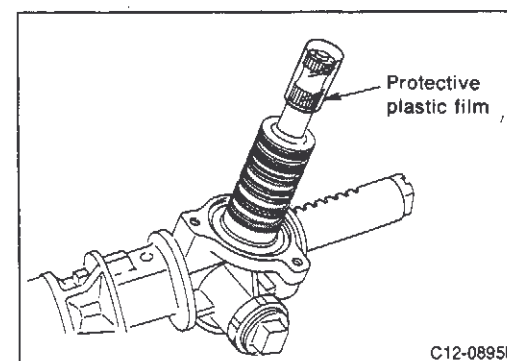

C11 STEERING

4. Removal and Installation, Assembly and Disassembly (Cont'd)

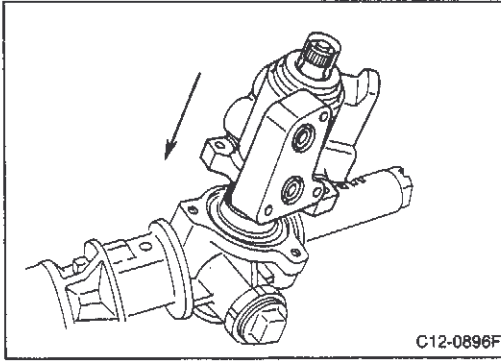

C12-0896F

- Install rear housing assembly straight ahead.

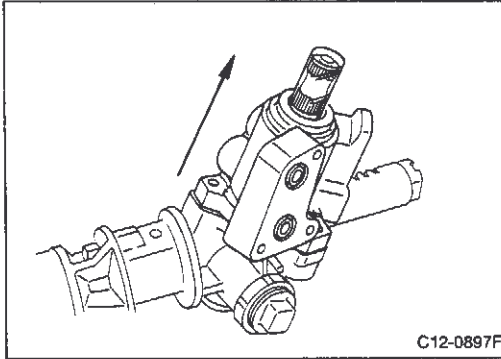

C12-0897F

- Insert rear housing assembly in pinion assembly and then remove protective plastic film.

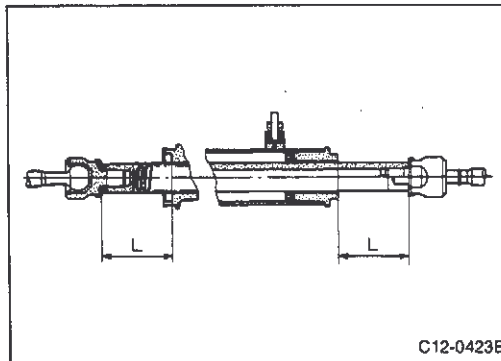

C12-0423B

[Point 15] Rear housing cover installation

- Position rack as shown in figure, and determine neutral position.

L dimension:
66.5 mm (2.618 in)

- Install rear cover cap so that protrusion of rear housing cover is positioned as shown in figure.

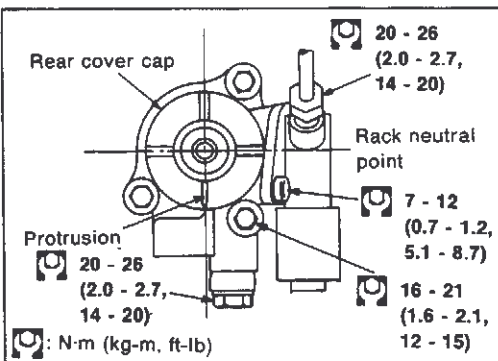

[Point 16] Spring (diaphragm spring) installation

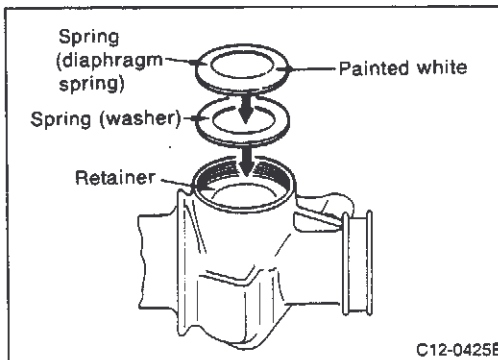

C12-0425B

- Always install retainer, spring washer, washer and diaphragm spring in this order.
- Make sure convex end (painted white) of diaphragm spring faces outward when installing.

C11 STEERING

4. Removal and Installation, Assembly and Disassembly (Cont'd)

[Point 17] Adjusting screw adjustment

① Steering gear assembly adjustment (without fluid in gears)

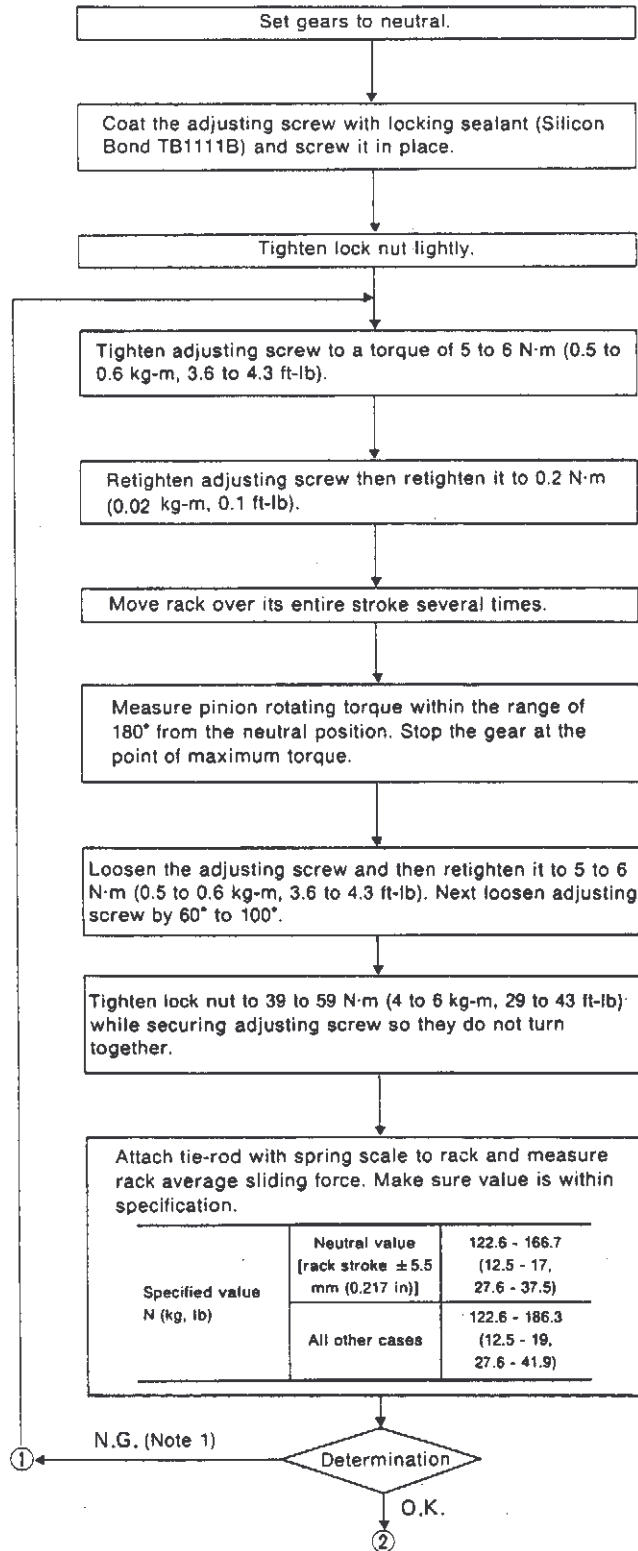
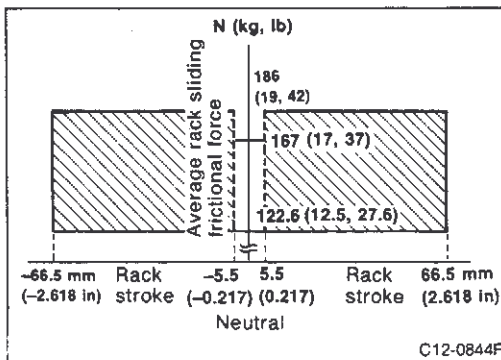
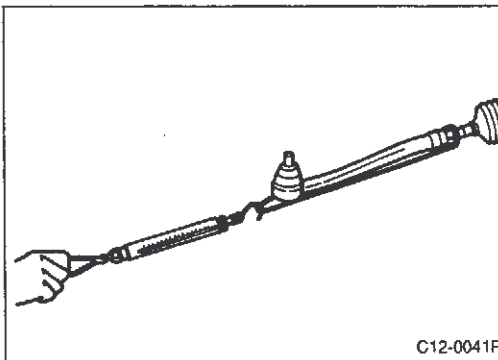
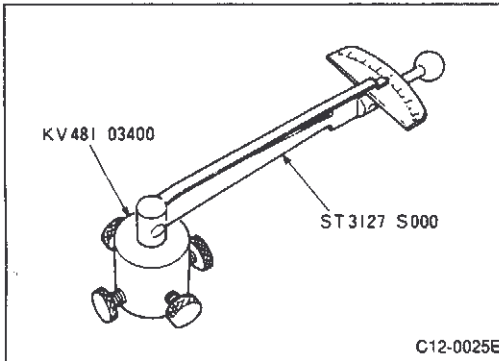
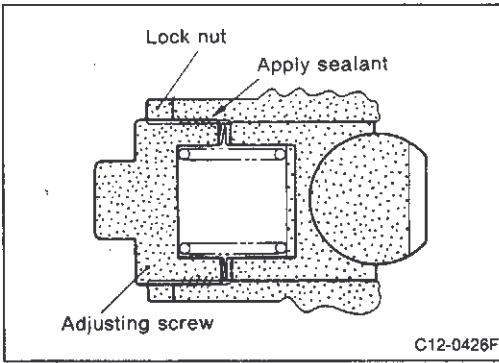

Note 1: If the sliding force is still out of specification even after readjustment, the steering gear is damaged and should be replaced.

C11 STEERING

4. Removal and Installation, Assembly and Disassembly (Cont'd)

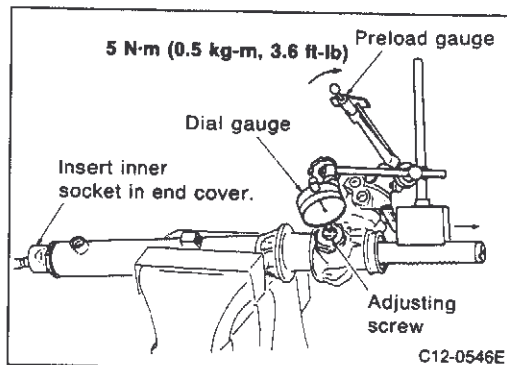
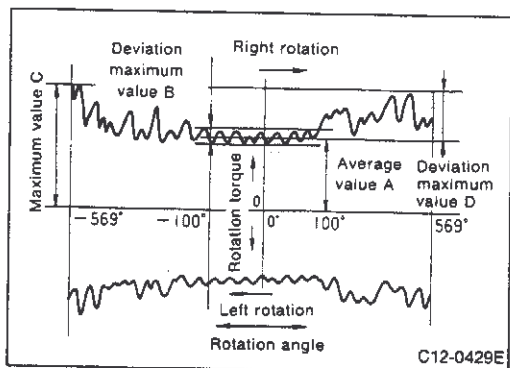

Measure pinion rotation torque with preload gauge. Make sure value is within specification.

Specification N·m (kg·m, ft·lb)	Neutral range (within ± 100°)	Average value A	0.8 - 1.3 (0.08 - 0.13, 0.6 - 0.9)
		Deviation maximum value B	0.4 (0.04, 0.3) max.
	Other	Maximum value C	1.9 (0.19, 1.4) max.
		Deviation maximum value D	0.6 (0.06, 0.4) max.

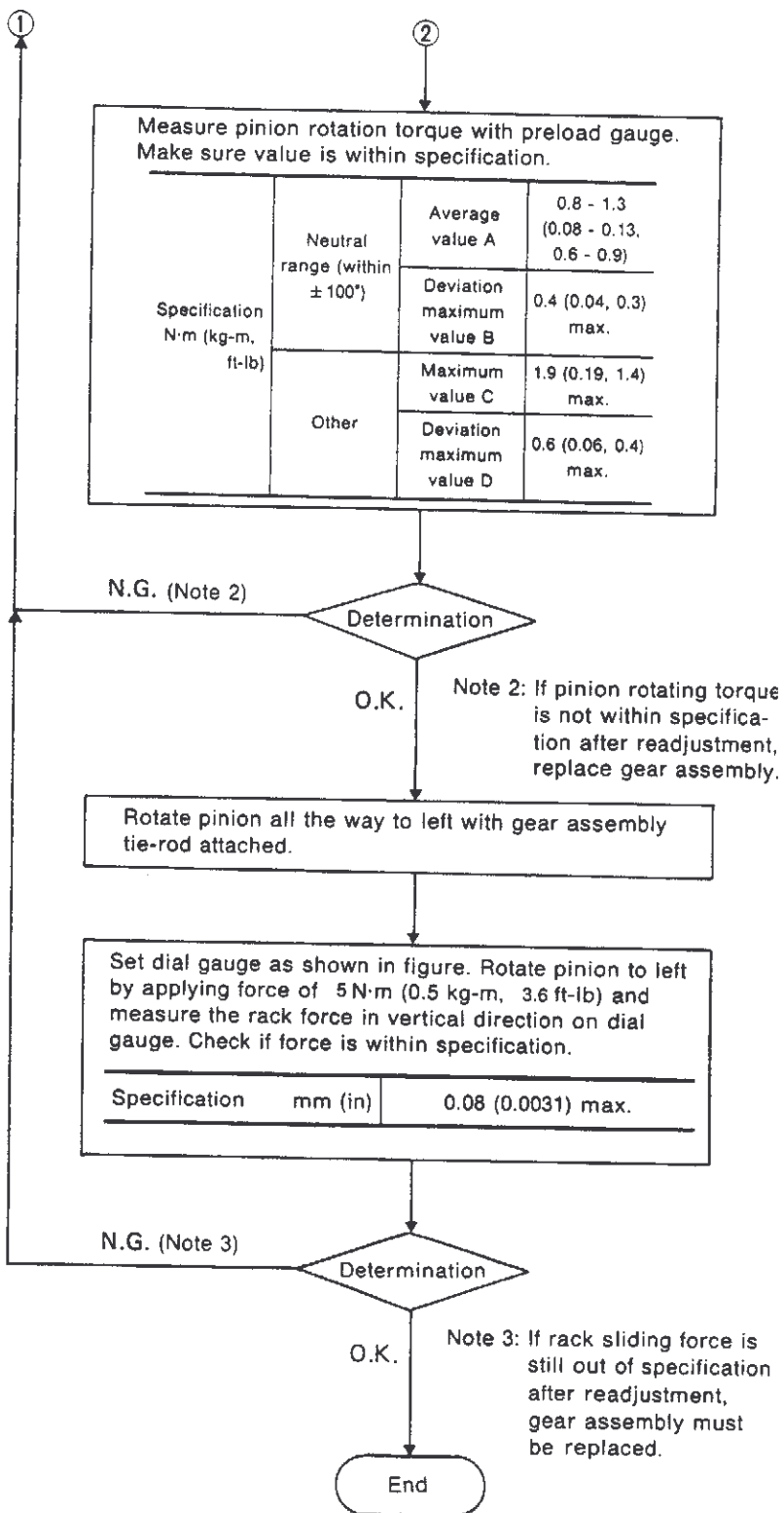

C11 STEERING

4. Removal and Installation, Assembly and Disassembly (Cont'd)

- ① **Steering gear assembly, on-vehicle inspection (filled with gear oil)**
- After adjusting steering gear as described in previous section, assemble in vehicle and perform following inspection.

Separate steering column lower joint, steering gear, tie-rod and knuckle arm.

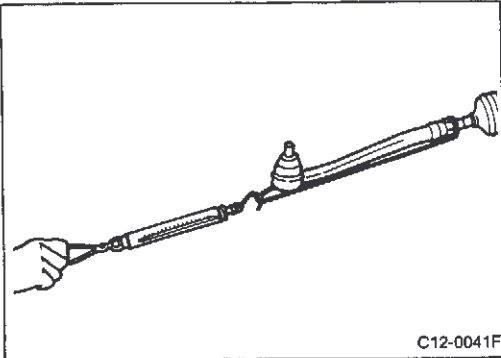

While pulling tie-rod slowly in the ± 11.5 mm (± 0.453 in) range from the neutral position, make sure rack sliding force (Note 4) is within specification.

Average rack sliding force A	284 N (29 kg, 64 lb) max.
------------------------------	---------------------------

Note 4: Measure rack sliding force under following conditions.

- ① Engine speed: Approx. 1,000 rpm
- ② Temperature: Approx. 55°C (122°F)
- ③ Rack speed: Approx. 3.5 mm/sec (0.138 in/sec)

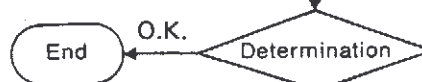

If rack sliding force is still out of specification after readjustment, gear assembly must be replaced.

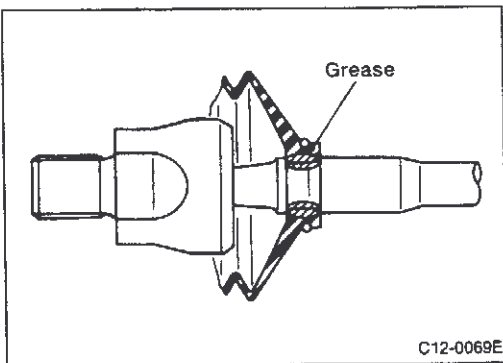
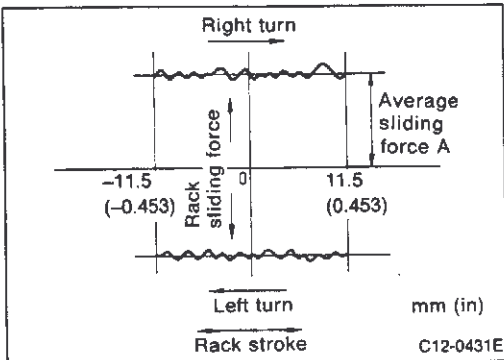

[Point 18] Dust boot and clamp installation

- Before installing boot, coat the contact surfaces between boot and tie-rod with grease.

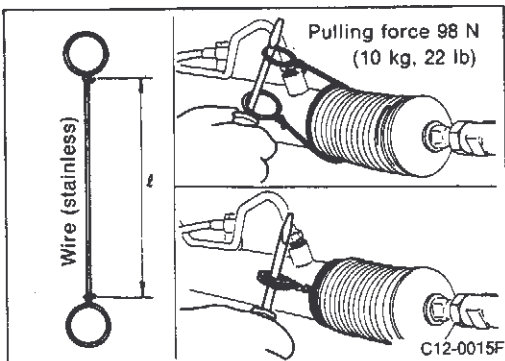

- The boot clamps are only located on large diameter side in two positions.
- The housing side and cylinder end side both have a length (l) of 396 mm (15.59 in).
- To install, wrap boot clamp around boot groove twice. Tighten clamp by twisting rings at both ends 4 to 4-1/2 turns with screwdriver while pulling with a force of approx. 98 N (10 kg, 22 lb).

C11 STEERING

4. Removal and Installation, Assembly and Disassembly (Cont'd)

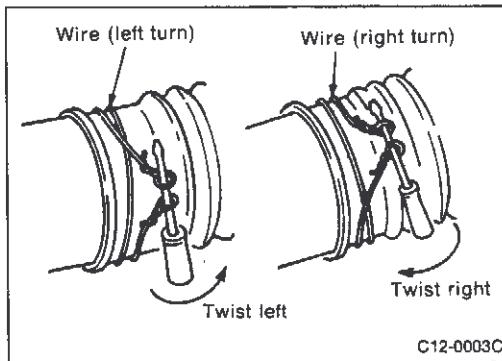

- Twist boot clamp in the direction shown in the figure at left.

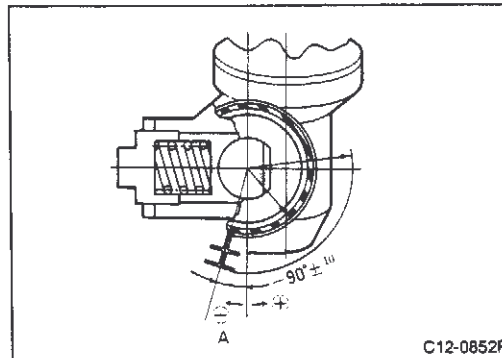

- Install boot clamp so that clamped portion will be behind the gear when gear housing is attached to the vehicle. (This will prevent interference with other parts.)
- After twisting clamp 4 to 4-1/2 times, bend it diagonally so it does not contact boot.

Angle A:
-80° to -100°

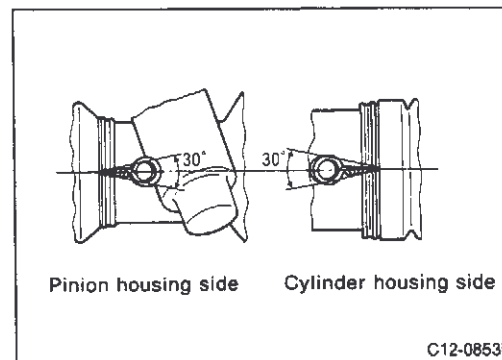

[Point 19]

- Set tie-rod length (dimension L) to following specification and tighten lock nut.

Specification:

126.5 mm (4.98 in)

CAUTION:

Always adjust toe-in after completing this operation. This dimension may change after toe-in adjustment.

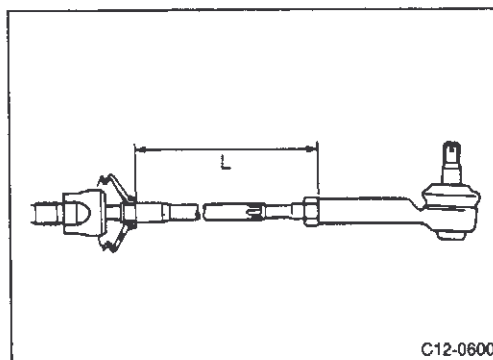

[Point 20] Rack oil seal, Teflon seal and ring seal inspection

- After assembling steering rack, check sealing as shown in figure.
- Connect vacuum hand pump (special service tool) to tube as shown in figure. Apply vacuum pressure of 53.3 kPa (40 mmHg, 15.75 inHg) for approx. 30 sec and check that there is no needle deflection.

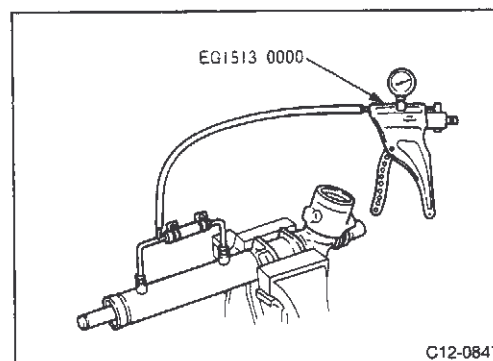

C11 STEERING

4. Removal and Installation, Assembly and Disassembly (Cont'd)

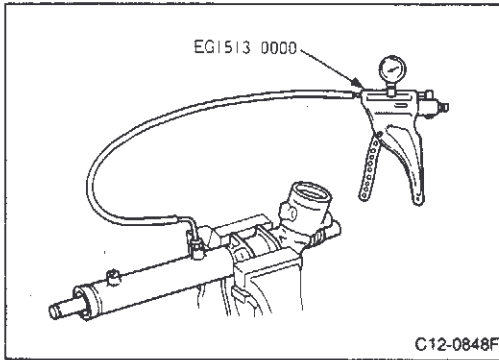

- To check rack seal ring (Teflon) and O-ring sealing, connect gauge to pinion side port as shown in figure. Apply vacuum pressure of 53.3 kPa (400 mmHg, 15.75 inHg) for approx. 30 sec and check that there is no needle deflection.

4-3 OIL PUMP, OIL TANK AND HYDRAULIC TUBES

Refer to C12 SUPER HICAS for power steering pump procedures.

C12 SUPER HICAS

PRECAUTIONS

- The final tightening of rubber bushings should be performed when vehicle is empty and on the ground. Wipe off any oil adhering to part surfaces because it reduces durability.
- Check wheel alignment when preparing suspension parts.
- Use flare nut wrench for removal and installation of steering pipe and power system flare nuts.
- Always adjust front and rear toe-in after power cylinder assembly removal and installation.

SPECIAL SERVICE TOOLS

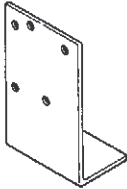
Tool name Tool number		Description
Pin punch KV321 01100	 C00-0084	Removing fail-safe valve tube seat
Attachment ST2770 0001	 C00-0144	Assembling and disassembling power steering pump

COMMERCIAL SERVICE TOOLS

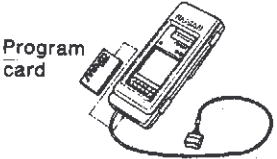
Tool name Tool number		Description
Pitman arm puller HT7256 0000	 C00-0231	Removing power cylinder outer link
CONSULT EG1180 0000	 Program card C00-0239	Control unit input/output (I/O) signal inspection

C12 SUPER HICAS

1. Summary

This section describes SUPER HICAS trouble diagnosis procedures. Refer to C7 FRONT SUSPENSION AND AXLE, C8 REAR SUSPENSION AND AXLE and C11 STEERING for further descriptions of other suspension and steering preparation operations.

System diagram

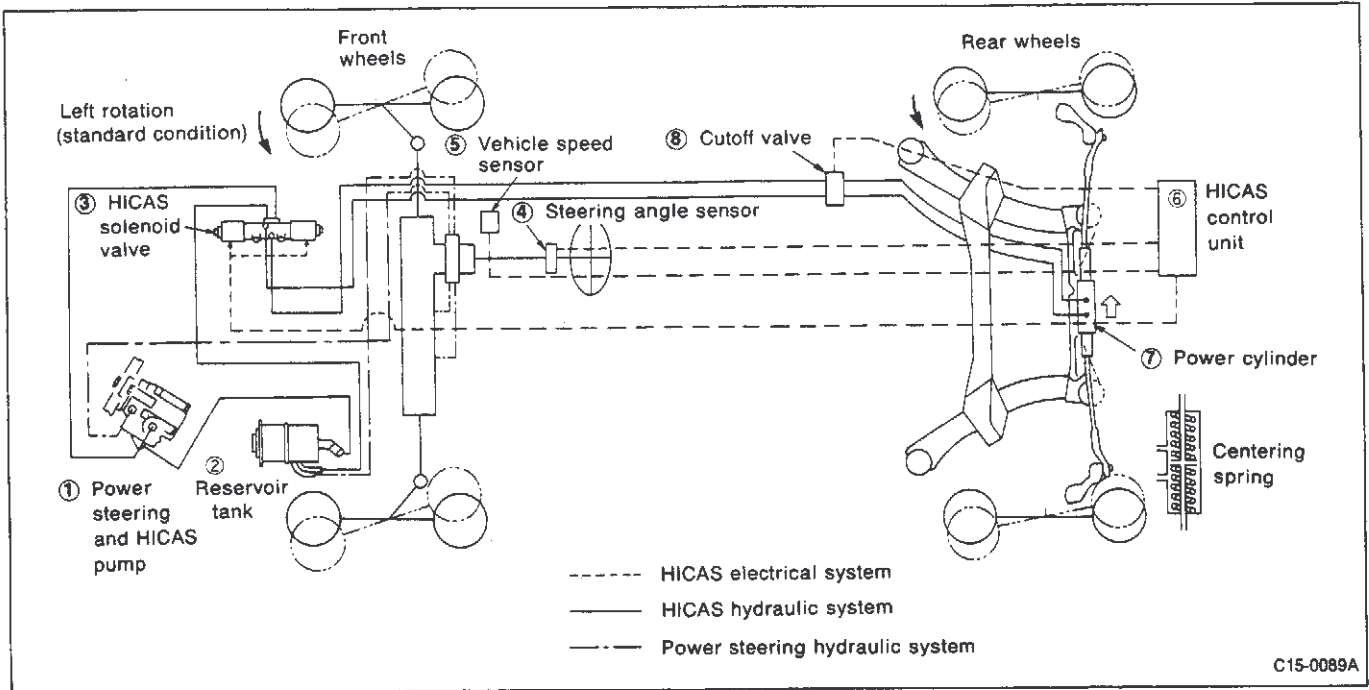

C12 SUPER HICAS

1. Summary (Cont'd)

Description		Engine	RB26DETT	
		Suspension	Front	Rear
Suspension type		Multi-link independent suspension		
Wheel alignment (empty vehicle)	Toe-in	mm (in)	1 ± 1 (0.04 ± 0.04)	2 ± 2 (0.08 ± 0.08)
	Camber	(°)	-0°55' ± 45'	-1°05' ± 30'
	Caster	(°)	3°40' ± 45'	—
	King pin inclination angle	(°)	15°25' ± 45'	—
	Side slip (reference)	mm (in)	-5 to 5 (-0.20 to 0.20)	
Shock absorber	Damping force [0.3 m (1.0 ft)/s] N·m (kg·m, ft·lb)	Expansion	1,746 (178, 392)	1,108 (113, 249)
		Compression	500 (51, 112)	402 (41, 90)
Coil spring	Spring constant	N/mm (kg/mm, lb/in)	23.5 (2.4, 134)	26.5 (2.7, 151)
	Free length	mm (in)	405 (15.94)	345 (13.58)
	Coil center diameter	mm (in)	110 (4.33) [low side 80 (3.15)]	100 (3.94) [low side 90 (3.54)]
	Wire diameter	mm (in)	12.3 (0.484)	11.8 (0.465)
	Number of active coils		7.92	7.29
Power cylinder	Inner diameter	mm (in)	60 (2.36)	
	Stroke	mm (in)	± 3 ± 0.1 (± 0.118 ± 0.004)	
	Spring rigidity (Static)	kg-s/mm	450 ± 22.5	
	Part number (55710)		05U10 (RB26DETT)	
Pump	Type		Fixed injection volume	
	Part number (49110)		05U00 (RB26DETT)	
Tension rod outer diameter		mm (in)	20 (0.79)	—
Stabilizer outer diameter		mm (in)	20 (0.79)	25.4 (1.000)
Maximum steering angle	(°)	Inner wheel	38° ^{+1°} _{-3°}	1° [Stroke: 3 mm (0.12 in)]
		Outer wheel	32°	1° [Stroke: 3 mm (0.12 in)]

Inspection specifications

Description	Specification	
Rear housing ball joint	Description	Ball joint
	Sliding torque	N·m (kg·m, ft·lb) 0.3 - 29 (0.03 - 0.3, 0.2 - 2.2)
	Swinging torque (spring scale conversion value)	N (kg, lb) 6.9 - 68.6 (0.7 - 7.0, 1.5 - 15.4)
	Axial end play	mm (in) 0 (0)
	Tightening torque	N·m (kg·m, ft·lb) 45 - 60 (4.6 - 6.1, 33 - 44)
Operation oil	Nissan power steering fluid	

C12 SUPER HICAS

2. On-vehicle Inspection and Adjustment

2-1 INSTALLATION INSPECTION

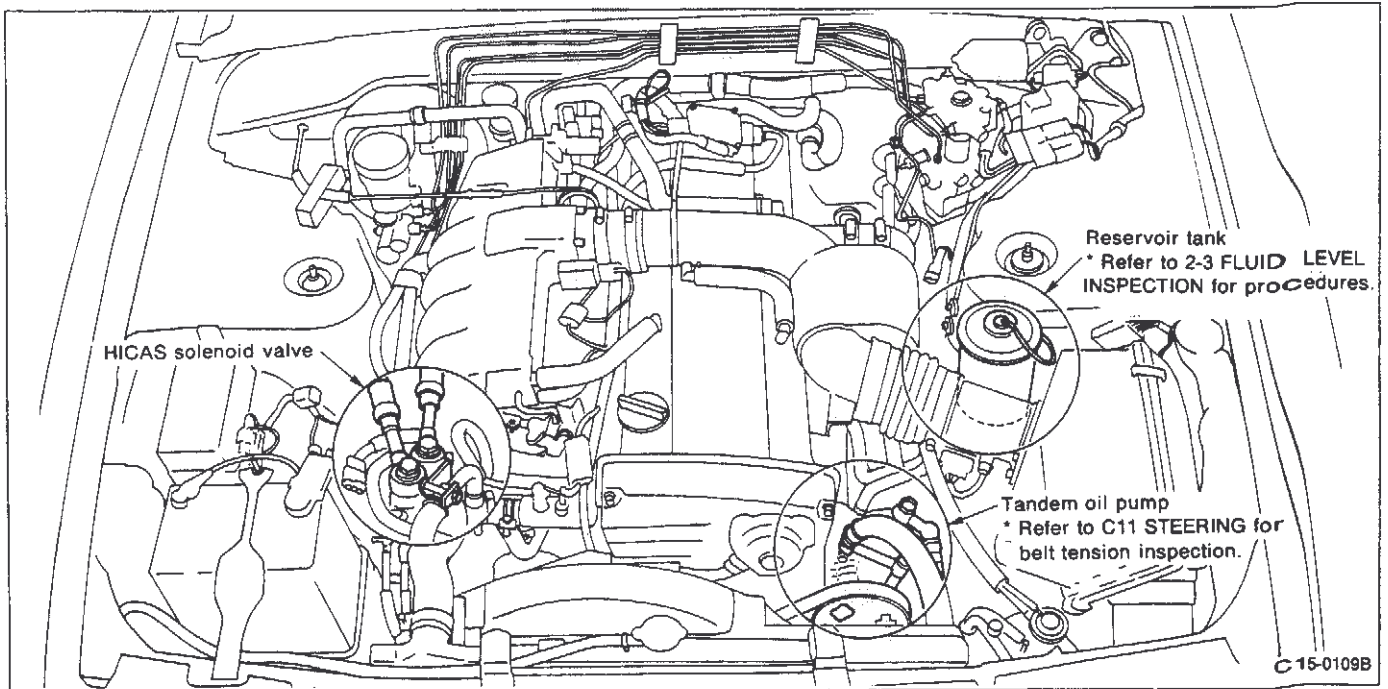

(1) Engine compartment

- Check the installation of each part and piping and wiring conditions.

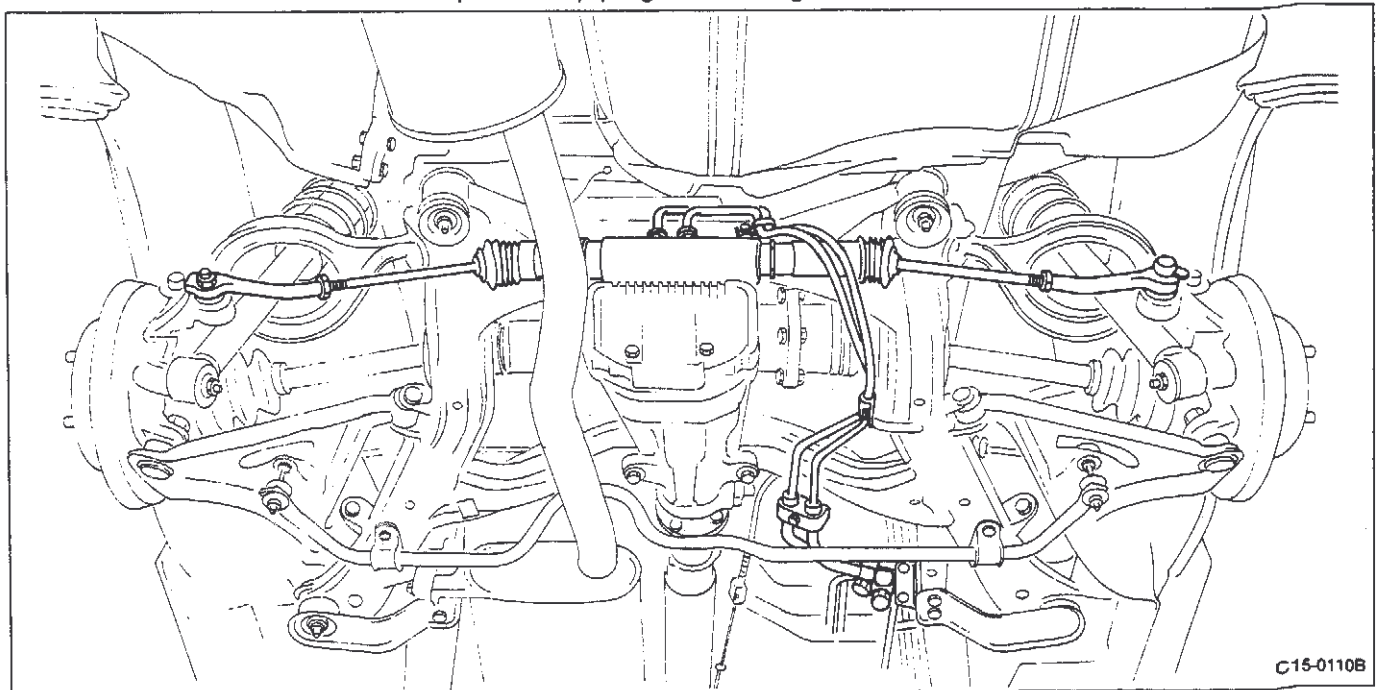

(2) Rear undercarriage

- Check installation of each part and pipe condition.
- Check that rubber parts (boots, insulators, etc.) are not cracked or damaged.
- Check installation condition of suspension parts.

C12 SUPER HICAS

2. On-vehicle Inspection and Adjustment (Cont'd)

(3) Rear parcel (trunk)

- Check wiring harness connector condition of HICAS control unit in the middle of rear parcel in trunk.

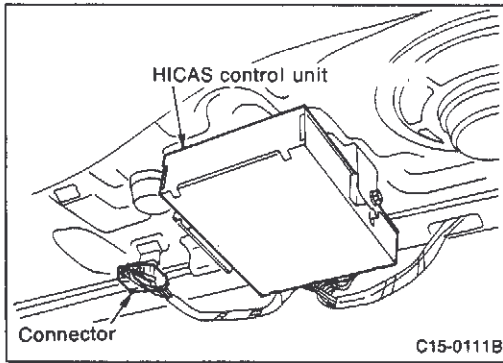

2-2 WHEEL ALIGNMENT INSPECTION AND ADJUSTMENT

- Refer to C7 FRONT SUSPENSION AND AXLE, C8 REAR SUSPENSION AND AXLE for wheel alignment inspection and adjustment procedures.

2-3 FLUID LEVEL INSPECTION

- Maintain the fluid level so that the lower surface of the float is maintained between the "L" and "H" marks on the gauge rod. The fluid level should be checked when the engine is stopped and the fluid temperature is normal.

CAUTION:

- (1) Never reuse fluid that has been removed.
- (2) Never use any other oil except the recommended type of power steering fluid.

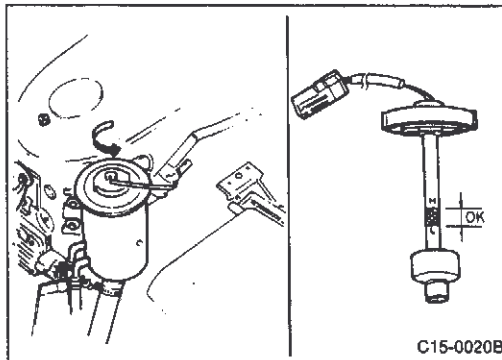

2-4 SYSTEM OPERATION INSPECTION

(1) When CONSULT is used:

Perform the following procedures. (2-man operation)

- ① Have a helper sit in the driver's seat and raise vehicle. (Use a two-pole lift or a center pole lift so that all four wheels are free to rotate.)
- ② Connect CONSULT unit to diagnostic connector and start engine.
- ③ Touch "START" on CONSULT display.
- ④ Touch "HICAS".

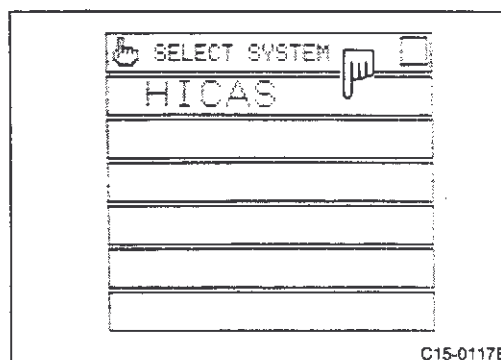
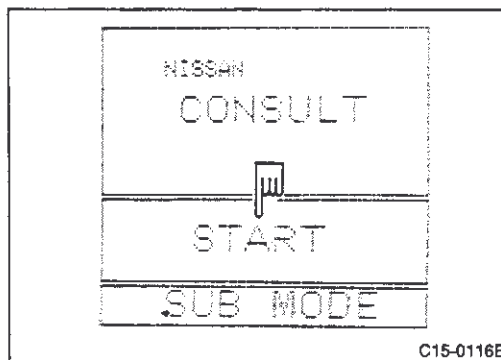

C12 SUPER HICAS

2. On-vehicle Inspection and Adjustment (Cont'd)

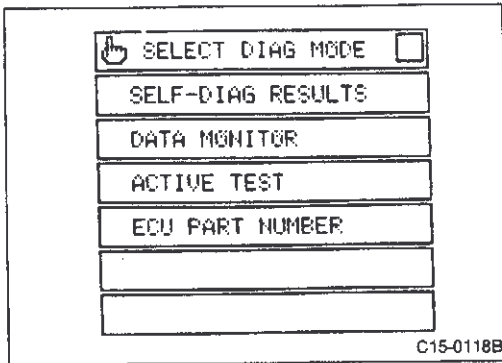

- ⑤ Touch "ACTIVE TEST".

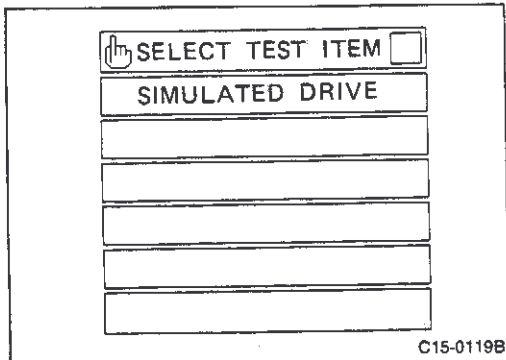

- ⑥ Touch "SIMULATED DRIVE".

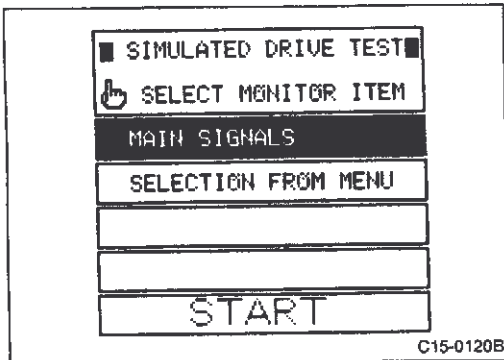

- ⑦ Touch "START" when MAIN SIGNALS display is reversed.

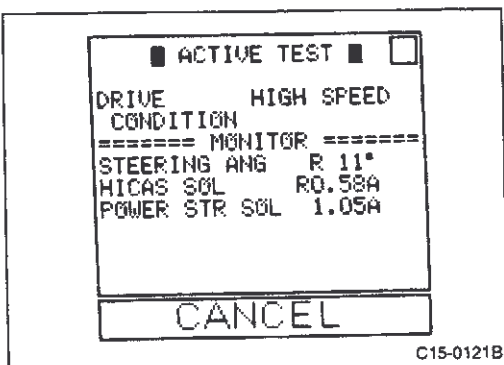

- ⑧ Touch "START". (high-speed mode set)

CAUTION:

After simulated drive condition has continued for 5 minutes, it will automatically cancel and CONSULT unit will then show "TEST IS INTERRUPTED TO AVOID OIL TEMP RISE" display. To cancel this mode during self-diagnosis, simply touch "CANCEL".

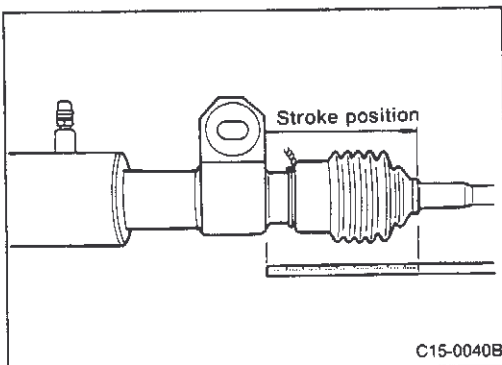

- ⑨ Operate engine at speeds greater than 2,000 rpm, and turn steering wheel 180° in one direction from the neutral position. Measure extension value of one power cylinder rod and retraction value of the other. Then, turn steering wheel 180° in the other direction from the neutral position and measure extension value of one cylinder rod and retraction value of the other. Determine strokes of respective power cylinders by adding (measured) extension and retraction values.

CAUTION:

Measure rod strokes in as short a period of time as possible.

C12 SUPER HICAS

2. On-vehicle Inspection and Adjustment (Cont'd)

Specifications mm (in)	When turned to the right: 3 mm (0.12 in)	Left rod: extended, Right rod: retracted
	When turned to the left : 3 mm (0.12 in)	Left rod: retracted, Right rod: extended
	Total stroke: 6 mm (0.24 in)	—

(2) When CONSULT is not used:

Perform the following operations. (2-man operation)

- ① Have a helper sit in the driver's seat and raise vehicle. (Use a 2-pole lift or a center pole lift so that the four wheels are free to rotate.)
- ② Turn ignition switch OFF.
- ③ Start engine. Turn steering wheel from left to right (at least 20° from the neutral position) 5 times or more, then depress foot brake pedal at least 5 times all within 10 seconds after ignition switch has been turned "ON".
- ④ Set steering wheel to a point approximately 10° from the neutral position and check to ensure that rear wheels turn to the left and right alternately.

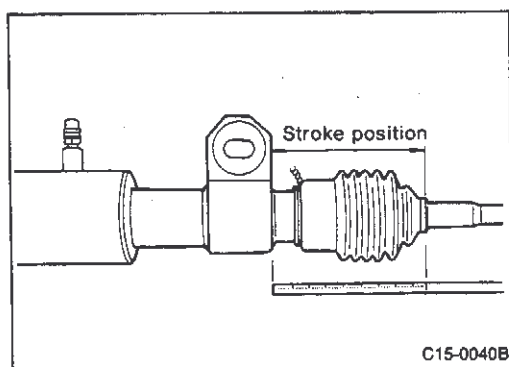

- ⑤ Operate engine at speed greater than 2,000 rpm, and turn steering wheel 180° in one direction from the neutral position. Measure extension value of one power cylinder rod and retraction value of the other. Then, turn steering wheel 180° in the other direction from the neutral position and measure extension value of one cylinder rod and retractor value of the other. Determine strokes of respective power cylinders by adding (measured) extension and contraction strokes.

CAUTION:

Measure rod strokes in as short a period of time as possible. Turn ignition switch OFF and cancel self-diagnosis.

Specifications mm (in)	When turned to the right: 3 mm (0.12 in)	Left rod: extended, Right rod: retracted
	When turned to the left : 3 mm (0.12 in)	Left rod: retracted, Right rod: extended
	Total stroke: 6 mm (0.24 in)	—

2-5 FLUID LEAK INSPECTION LOCATIONS

- Refer to C11 STEERING, 2. On-vehicle Inspection and Adjustment for descriptions of SUPER HICAS power steering fluid leak inspection locations.
- This section describes the leak inspection locations for the SUPER HICAS power cylinder.

C12 SUPER HICAS

2. On-vehicle Inspection and Adjustment (Cont'd)

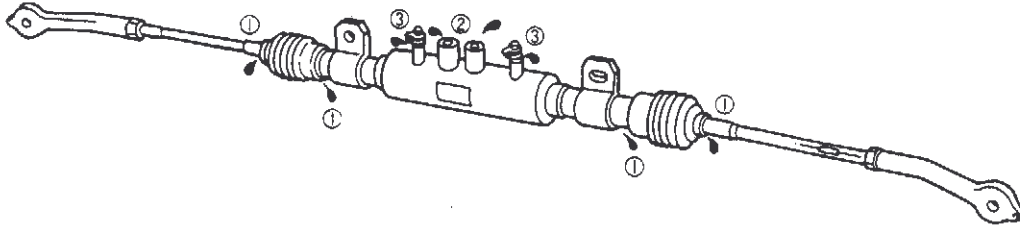

C15-0044B

Note: If leakage locations are not clearly visible, wash area with white gasoline or equivalent solvent and check for leaks again.

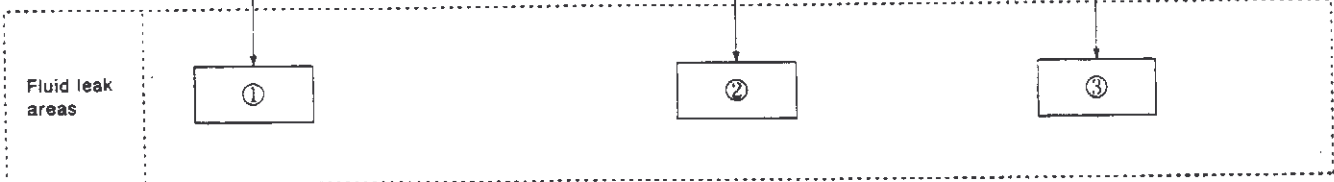
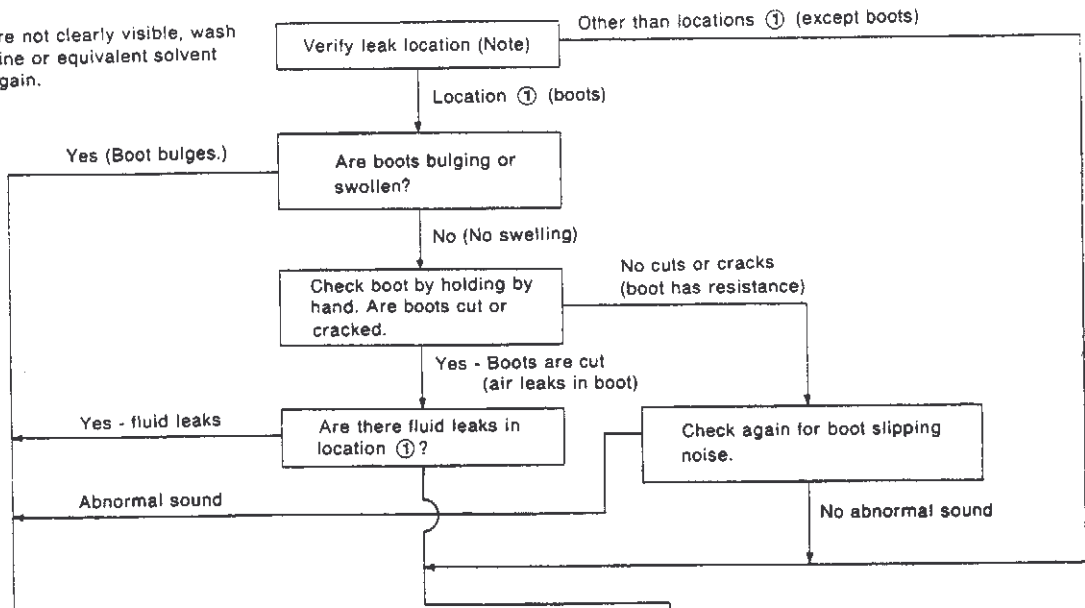

C15-0045B

C12 SUPER HICAS

2. On-vehicle Inspection and Adjustment (Cont'd)

Fluid leak location	① Dust boot	② Power cylinder tube connections	③ Power cylinder air bleeder
On-vehicle inspection locations	—	Power steering tube tightening torque ● Right port side: 39 - 49 N·m (4.0 - 5.0 kg-m, 29 - 36 ft-lb) ● Left port side: 39 - 49 N·m (4.0 - 5.0 kg-m, 29 - 36 ft-lb)	Air bleeder tightening torque ● Right side: 6 - 8 N·m (0.6 - 0.8 kg-m, 4.3 - 5.8 ft-lb) ● Left side: 6 - 8 N·m (0.6 - 0.8 kg-m, 4.3 - 5.8 ft-lb)
Preparation description (parts requiring replacement)	Power cylinder assembly	Tubes	(Air bleeder)
Related parts requiring inspection	—	Power cylinder assembly	

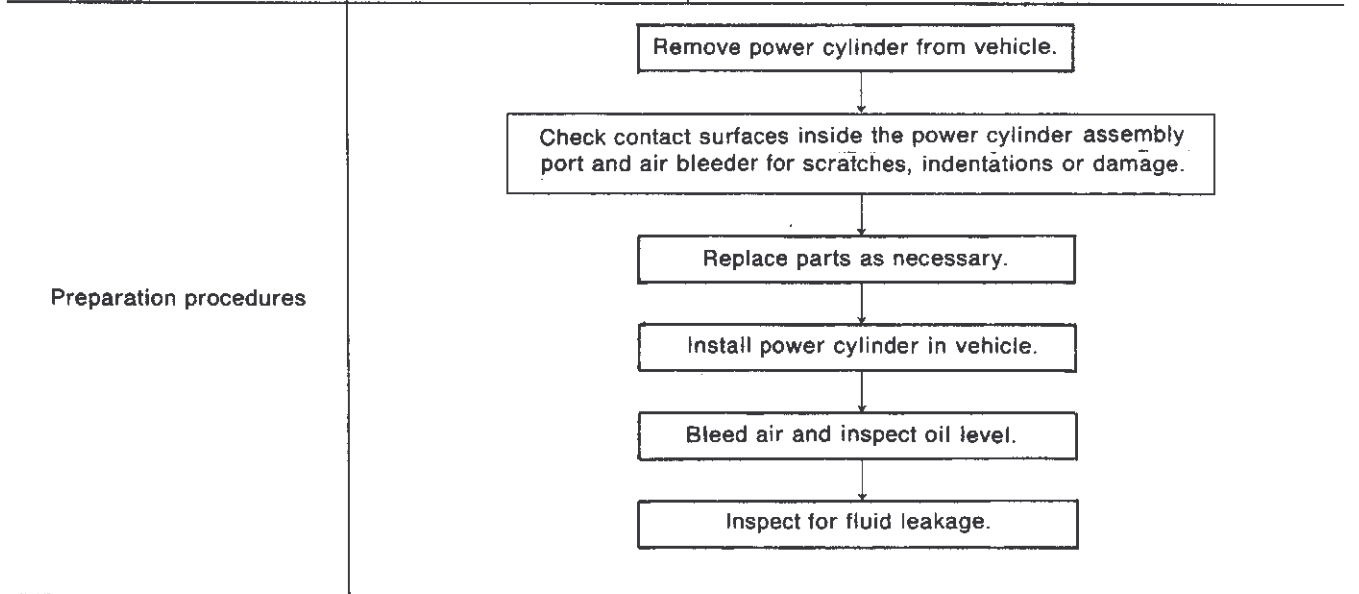

2-6 AIR BLEEDING

- Refer to "4-1 POWER CYLINDER AND LOWER LINK", ① Removal and installation for description HICAS system air bleeding procedures.

C12 SUPER HICAS

3. Trouble Diagnoses

3-1 ELECTRICAL SYSTEM INSPECTION PREPARATION

(1) Circuit diagram and control unit installation position

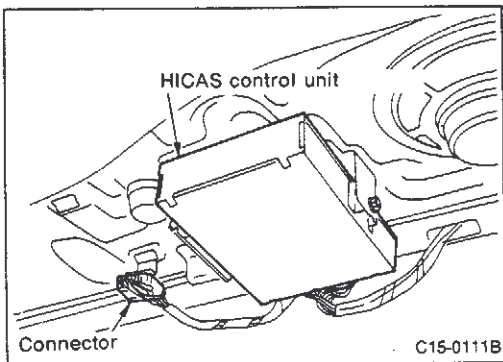
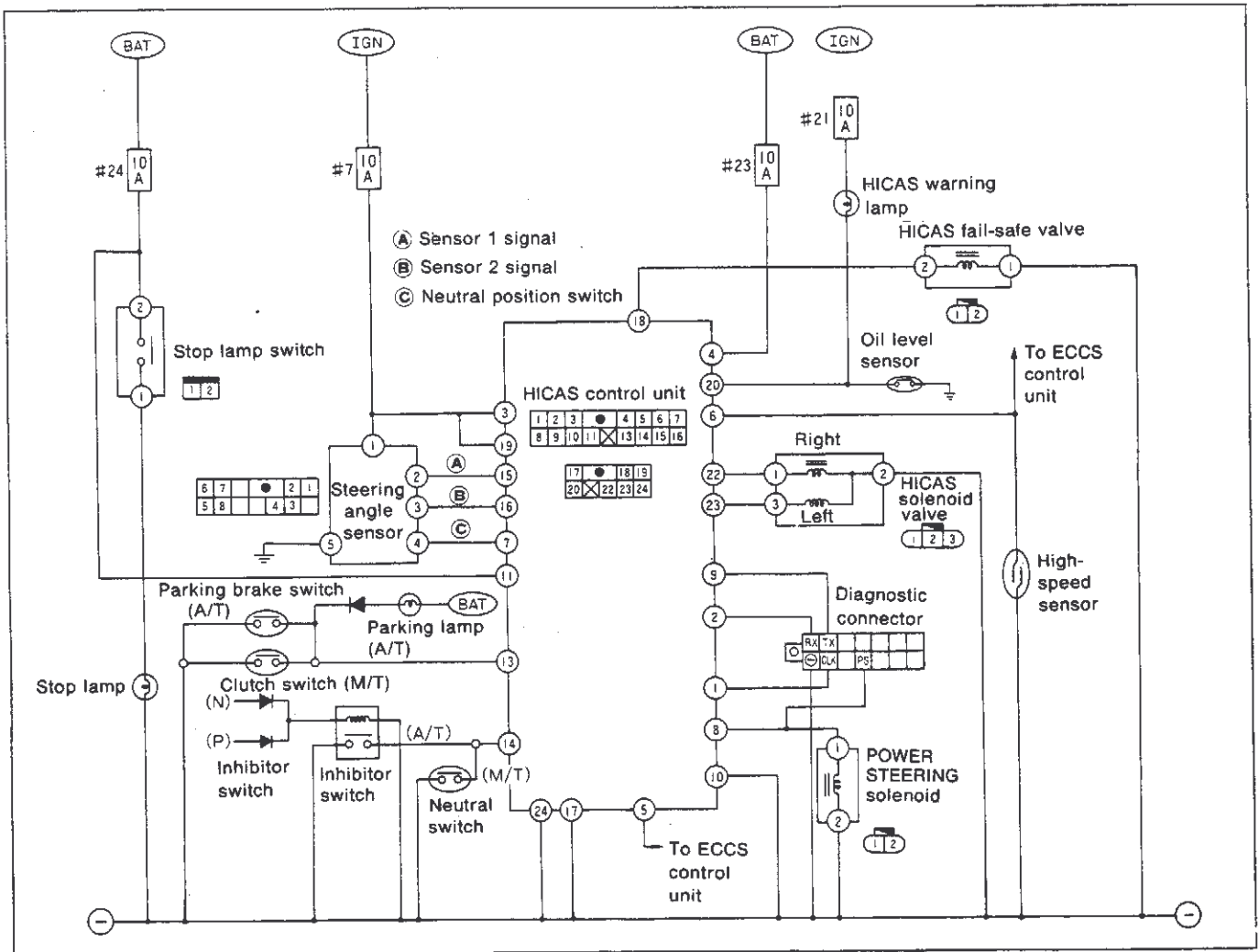

HICAS control unit installation position

- The unit is located below the rear parcel shelf.

C12 SUPER HICAS

3. Trouble Diagnoses (Cont'd)

(2) Trouble diagnosis when CONSULT is used



① Self-diagnostic items

Diagnostic item	Description	Remarks
CAR SPEED SENSOR [No signal] (- a)	<ul style="list-style-type: none"> ● No vehicle speed signal is entered after vehicle has been operated above a certain speed. 	
CAR SPEED SENSOR [SIG-SUDDEN TURN] (- b)	<ul style="list-style-type: none"> ● Vehicle speed signal changes abruptly during operation. 	
STEERING ANGLE SEN [NO ANG SIGNAL] (- a)	<ul style="list-style-type: none"> ● Steering angle has not changed while driving at a speed of at least 60 km/h (37 MPH). 	
STEERING ANGLE SEN [NO NEUT SIGNAL] (- b)	<ul style="list-style-type: none"> ● Neutral (ON) signal is not entered after vehicle has been driven. 	
STEERING ANGLE SEN [NEUT SIG-360° OFF] (- c)	<ul style="list-style-type: none"> ● Neutral (ON) signal is not entered even after steering wheel has been turned at least 360°. 	
STEERING ANGLE SEN [NEUT SIG-30° ON] (- d)	<ul style="list-style-type: none"> ● Neutral (OFF) signal is not entered even after steering wheel has been turned at least 50°. ● Neutral (ON) signal is continuously shown at steering angle of at least 30°. 	
FAILSAFE VALVE [ABNORMAL SIGNAL]	<ul style="list-style-type: none"> ● Output terminal voltage is abnormal due to broken or shorted HICAS fail-safe valve circuit. 	
HICAS SOLENOID-R [ABNORMAL SIGNAL]	<ul style="list-style-type: none"> ● Output terminal voltage is abnormal due to broken or shorted HICAS solenoid (RH) circuit. 	
HICAS SOLENOID-L [ABNORMAL SIGNAL]	<ul style="list-style-type: none"> ● Output terminal voltage is abnormal due to broken or shorted HICAS solenoid (LH) circuit. 	
POWER STEERING SOL [ABNORMAL SIGNAL]	<ul style="list-style-type: none"> ● Output terminal voltage is abnormal due to broken or shorted power steering solenoid circuit. 	

C12 SUPER HICAS

3. Trouble Diagnoses (Cont'd)

② Data monitoring items

○: Standard △: Optional selection

Diagnostic item	Monitor item selection		Remarks
	All signals	Selection from menu	
CAR SPEED (km/h or MPH)	○	△	
STEERING ANG (R/L°)	○	△	Abnormal value is shown before straight-ahead position ("0") is set and after battery is disconnected and reconnected.
NEUTRAL SIG (ON/OFF)	○	△	
STOP LAMP SW (ON/OFF)	○	△	
PKB/CLUTCH SW (ON/OFF)	○	△	Clutch switch signal in M/T vehicles, parking brake switch signal in A/T vehicles.
NEUTRAL SW (ON/OFF)	○	△	Neutral switch signal in M/T vehicles, inhibitor relay (N or P position) in A/T vehicles.
ENG REV (OVER 1,500) or (UNDER 1,500)	○	△	Engine speed greater than/less than 1,500 rpm is shown.
HICAS SOL (R/L A)	○	△	Controlled current flow from control unit to HICAS solenoid and direction of current control are shown.
POWER STR SOL (A)	○	△	Controlled current flow from control unit to power steering is shown.
FAILSAFE/V (ON/OFF)	○	△	ON (when connected) or OFF (when disconnected) is shown.
FAILSAFE (CUT/NON)	○	△	NON (fail-safe valve ON) refers to "normal" condition. CUT (fail-safe valve OFF) when "fail-safe" condition is shown.
WARNING LAMP (ON/OFF)	○	△	Illumination control of control unit HICAS warning lamp is shown.
■ VOLTAGE (V)		△	Voltage measured with voltage probes is shown.
■ PULSE (msec, Hz or %)		△	Value measured with pulse probes is shown. If pulse cannot be measured, "#" is shown. "#" is also shown at left of final data until measurement results are determined.

C12 SUPER HICAS

3. Trouble Diagnoses (Cont'd)

(3) Trouble diagnosis by self-diagnosis

① Self-diagnosis (When CONSULT is used)

- Turn ignition switch OFF.
- Connect CONSULT unit to diagnostic connectors. (Diagnostic connectors are located in fuse block.)

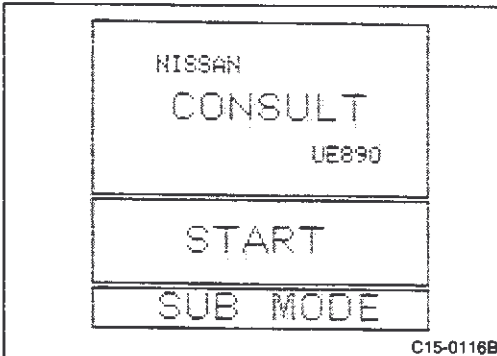
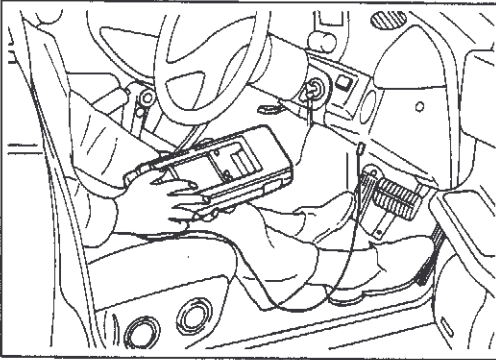

- Start engine.
- Touch "START" on CONSULT display.

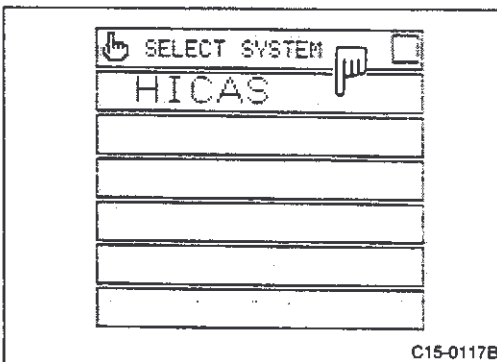

- Touch "HICAS".

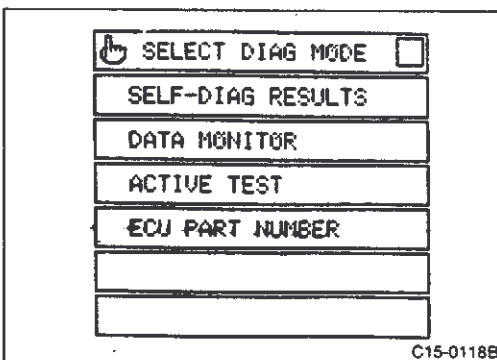

- Touch "SELF-DIAG RESULTS".

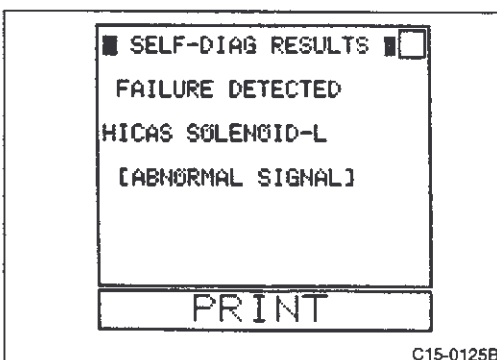

- Self-diagnostic results are shown on display.

C12 SUPER HICAS

3. Trouble Diagnoses (Cont'd)

For reference:

Recording input/output signals using data monitor function. 

- Start engine.
- Touch "START" (on CONSULT display).

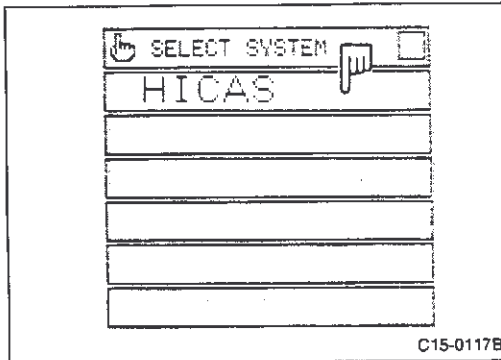
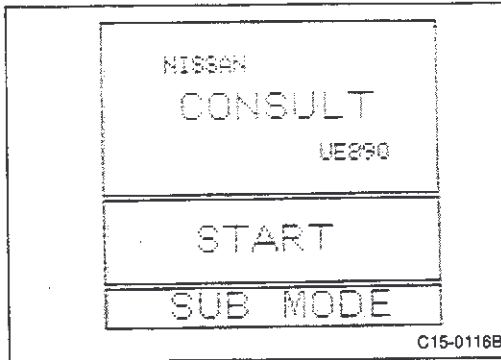

- Touch "HICAS".

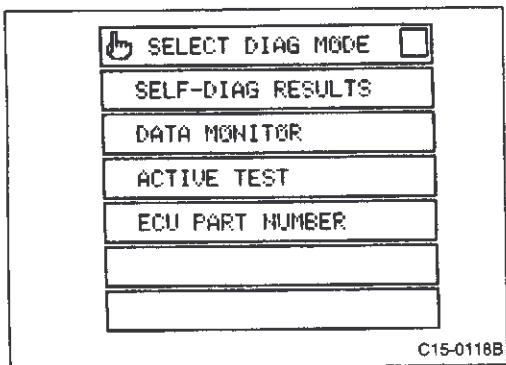

- Touch "DATA MONITOR".

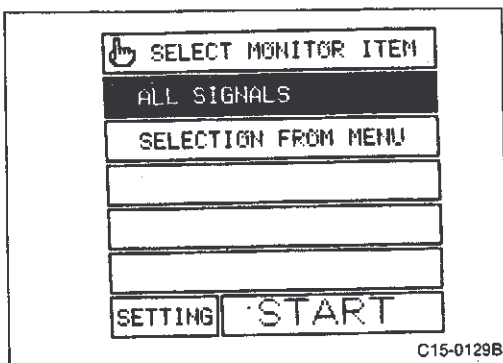

- Check to ensure that the ALL SIGNALS display is reversed. Touch "START".

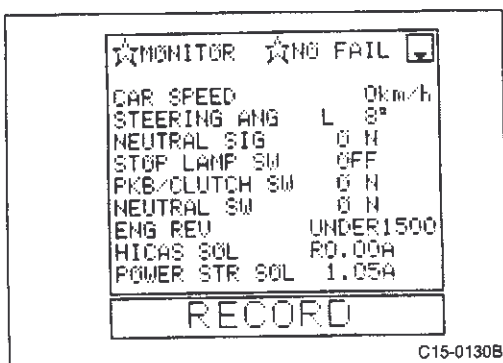

- Touch "RECORD" to record data. Make sure that ON-OFF signal is produced when signal is entered from each sensor while monitoring.

CAUTION:

To cancel data recording during operation, touch "CANCEL".

C12 SUPER HICAS

3. Trouble Diagnoses (Cont'd)

② Self-diagnosis (When CONSULT is not used)

Self-diagnosis procedures

a Input starting conditions for self-diagnosis.

- 1) Turn ignition switch "OFF".
- 2) M/T vehicles: Set shift lever in neutral.
A/T vehicles: Set shift lever to "P" or "N".
- 3) Immediately start engine.
- 4) Turn steering wheel from left to right (at least 20° from the neutral position) 5 times or more, then depress foot brake pedal at least 5 times, all within 10 seconds after ignition switch has been turned "ON".

b Input self-diagnosis item.

- 1) Depress and release foot brake pedal.
- 2) Turn steering wheel from left to right (at least 20°) from the neutral position.
- 3) M/T vehicles: Depress clutch and move shift lever to any gear other than neutral and then return clutch and shift lever to original position.
A/T vehicles: Disengage and engage parking brake lever. Move shift lever to any position other than Neutral or Parking and return it to Parking.
- 4) Move car at least 2 to 3 meters (7 to 10 ft) forward and proceed at an indicated speed of at least 2 km/h (1 MPH) in self-diagnosis mode.

c Self-diagnosis items

- (1) RH solenoid output
- (2) LH solenoid output
- (3) Fail-safe valve output
- (4) Power steering solenoid output
- (5) Vehicle speed signal.
- (6) Steering angle signal.
- (7) Steering angle neutral signal
- (8) (A/T) parking brake signal, (M/T) clutch signal
- (9) (A/T) inhibitor signal, (M/T) neutral signal

d Self-diagnosis display pattern

- 1) When all systems are normal:
HICAS flashes at 0.25 sec (4 Hz) intervals.
- 2) If fail-safe system was operated (fail-safe valve is operating) when ignition switch was OFF for the last time, fail-safe items will be displayed in numerical order in modes indicated. After all items are displayed, display is repeated again.

Example:

The warning lamp displays abnormal mode (1 sec. ON) in following sequence: (2) HICAS solenoid LH, (4) power steering solenoid and (5) vehicle speed sensor.

CAUTION:

After this display is shown, when ignition key is turned OFF the next display is ②.

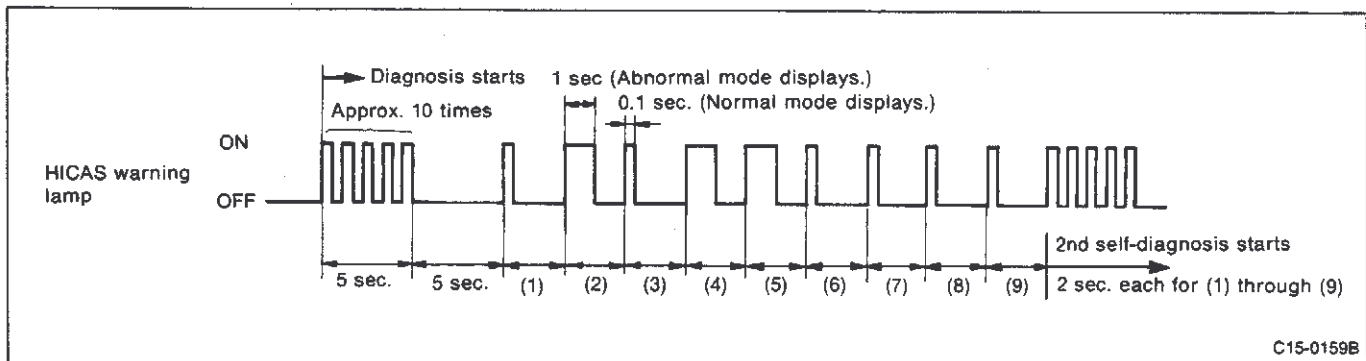

C12 SUPER HICAS

3. Trouble Diagnoses (Cont'd)

- 3) If fail-safe system was not operated when ignition switch was OFF for the last time, display will show self-diagnosis results in numerical sequence in modes indicated below. After all self-diagnosis, results are shown and display is repeated again.

Example:

The warning lamp displays abnormal mode (1 sec. ON) in following sequence: (2) HICAS solenoid LH, (4) power steering solenoid and (7) Steering angle neutral signal.

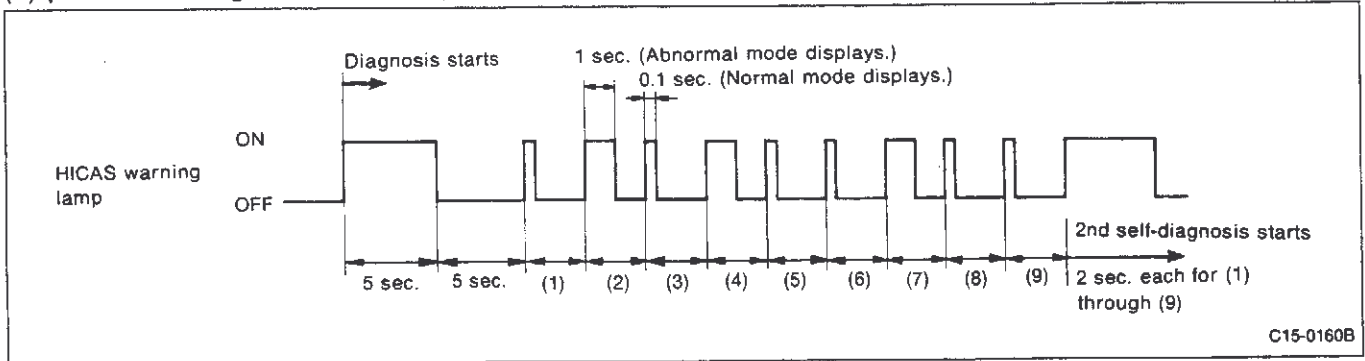

ⓐ Canceling the self-diagnosis function

The three methods for canceling the self-diagnosis are described below.

- The self-diagnosis system is canceled by turning ignition switch "OFF".
- The self-diagnosis system is canceled by a vehicle speed of 30 km/h (19 MPH) or over.
- After the self-diagnosis has been operated for approximately 5 minutes, the self-diagnosis system will be automatically canceled.

C12 SUPER HICAS

3. Trouble Diagnoses (Cont'd)

(4) Diagnostic procedures

A. When self-diagnosis function is not used:

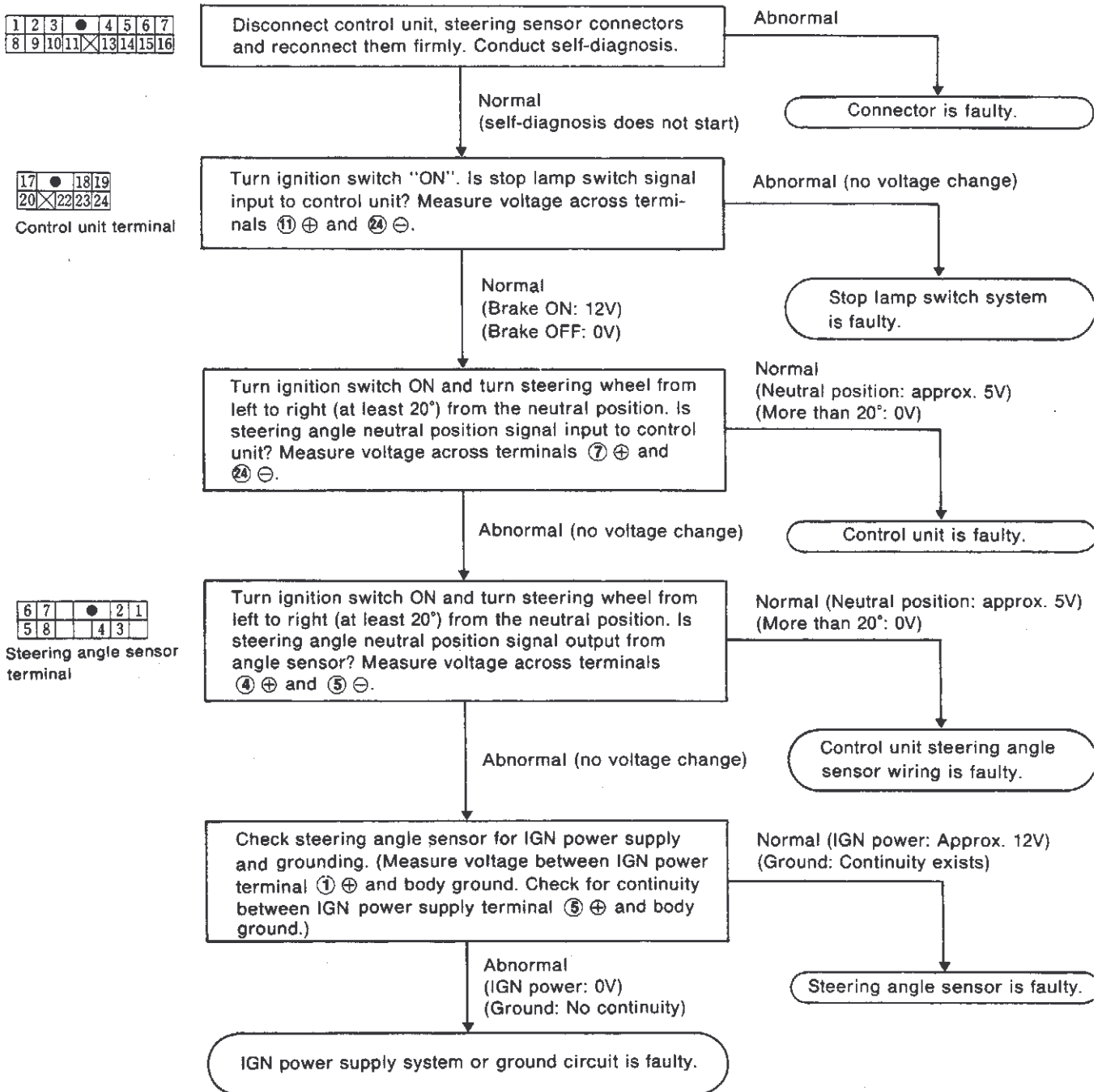

C12 SUPER HICAS

3. Trouble Diagnoses (Cont'd)

B. HICAS solenoid (right and left) output is not present. [C Self-diagnosis items (1) and (2)]

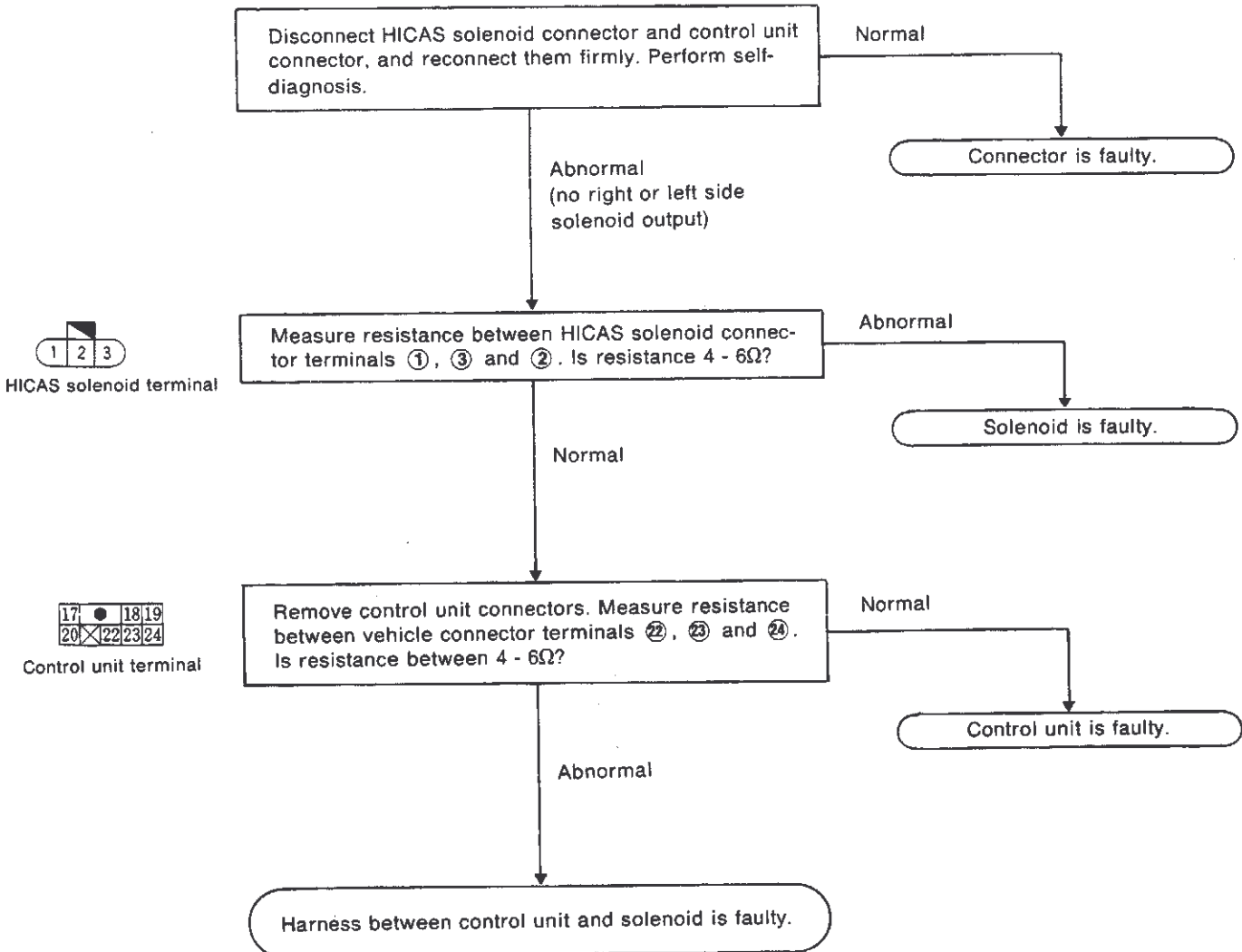

C12 SUPER HICAS

3. Trouble Diagnoses (Cont'd)

C. Fail-safe output is not present. [C Self-diagnosis items (3)]

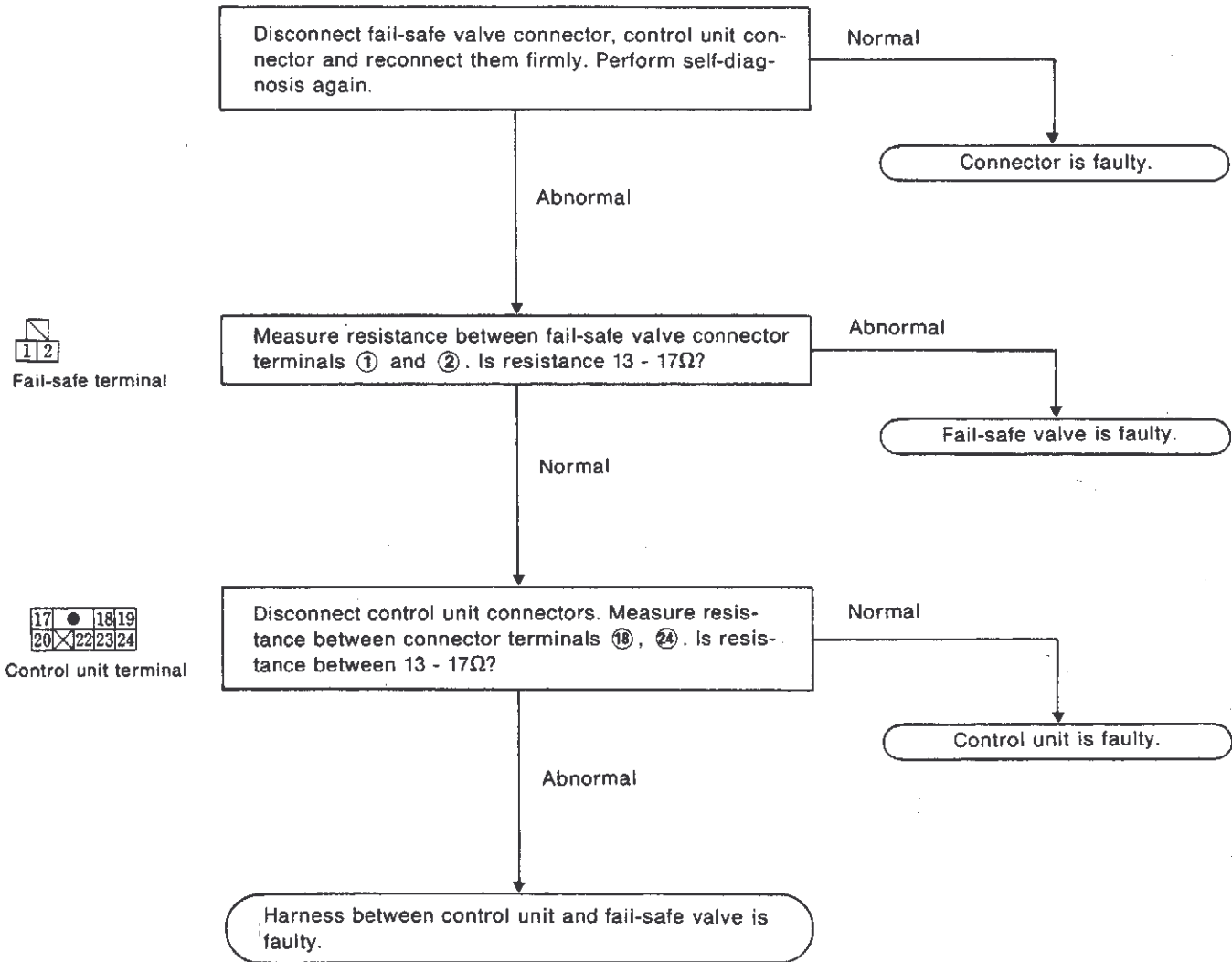

C12 SUPER HICAS

3. Trouble Diagnoses (Cont'd)

D. Power steering solenoid output is not present. [C Self-diagnosis items (4)]

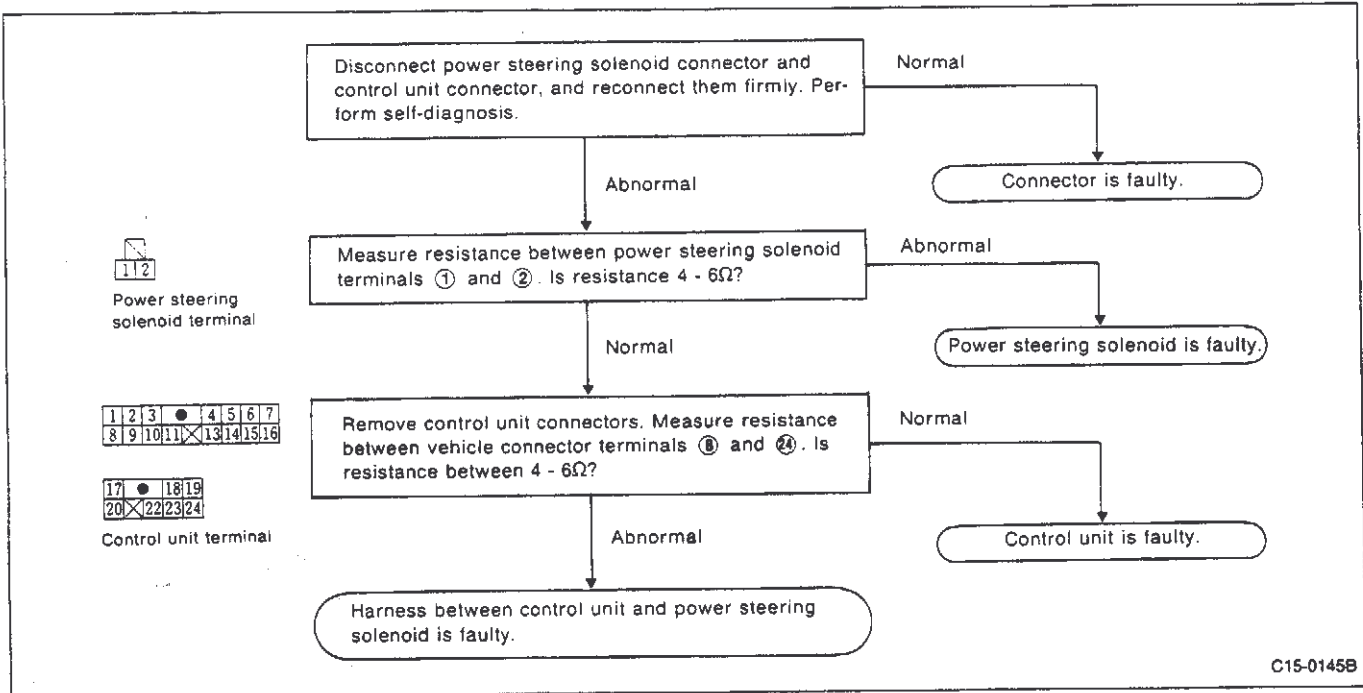

E. Vehicle speed signal is not present. [Self-diagnosis procedure (5)]

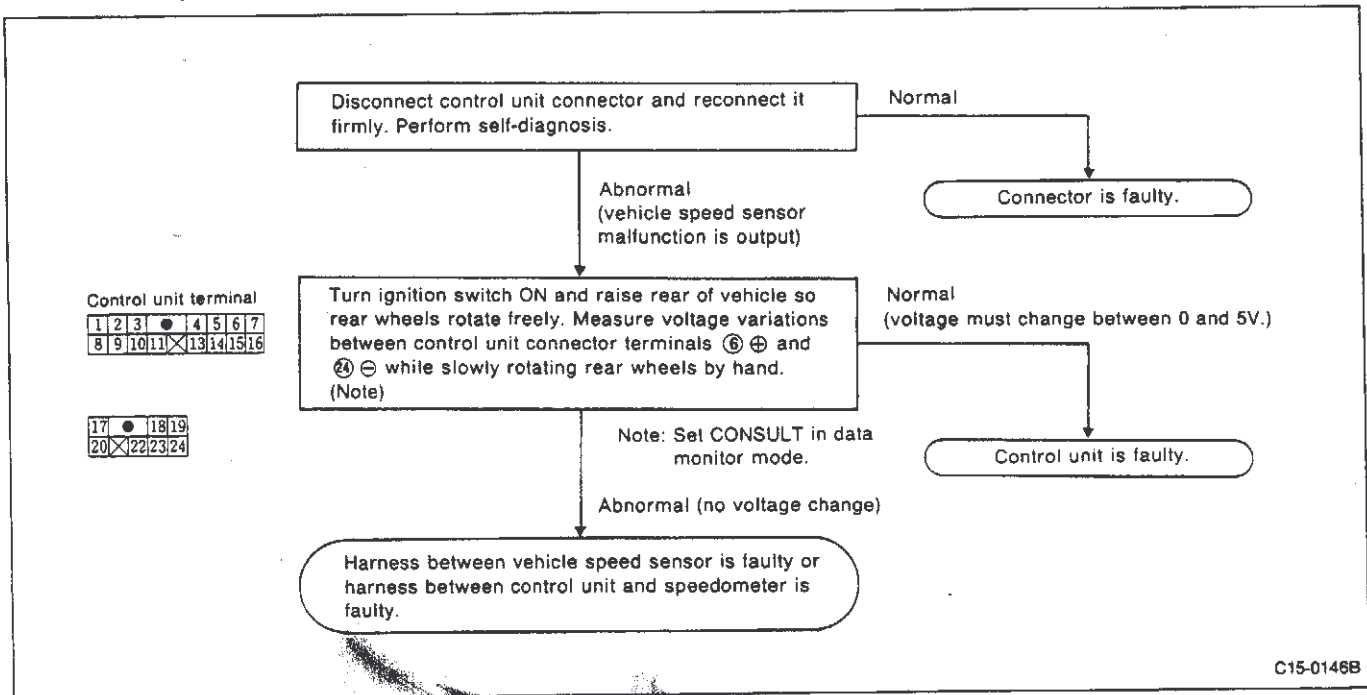

C12 SUPER HICAS

3. Trouble Diagnoses (Cont'd)

F. Steering angle signal is not present. [C Self-diagnosis items (6) and (7)]

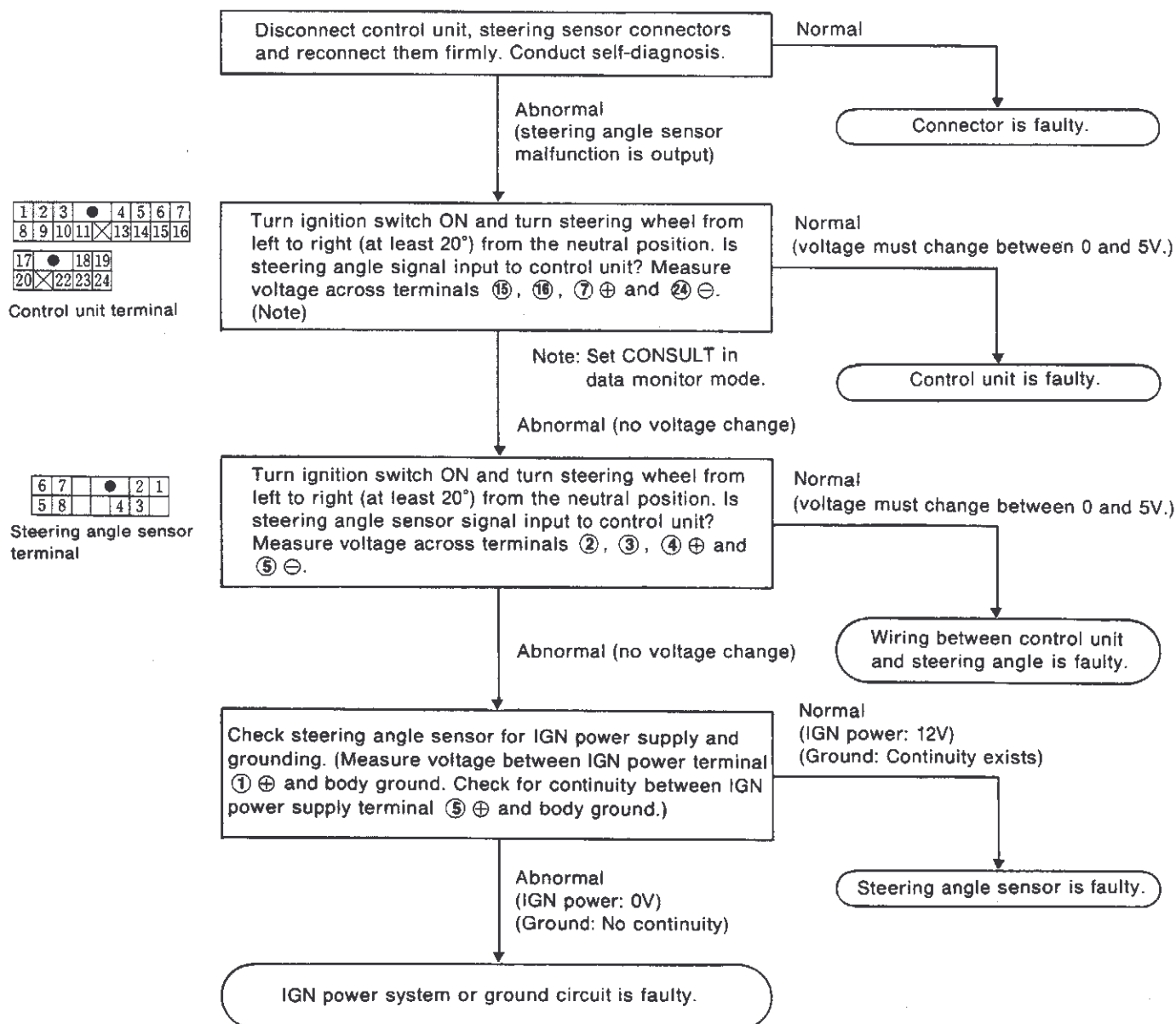

C12 SUPER HICAS

3. Trouble Diagnoses (Cont'd)

G. Parking brake (A/T) or clutch switch (M/T) input is not present. [C Self-diagnosis items (8)]

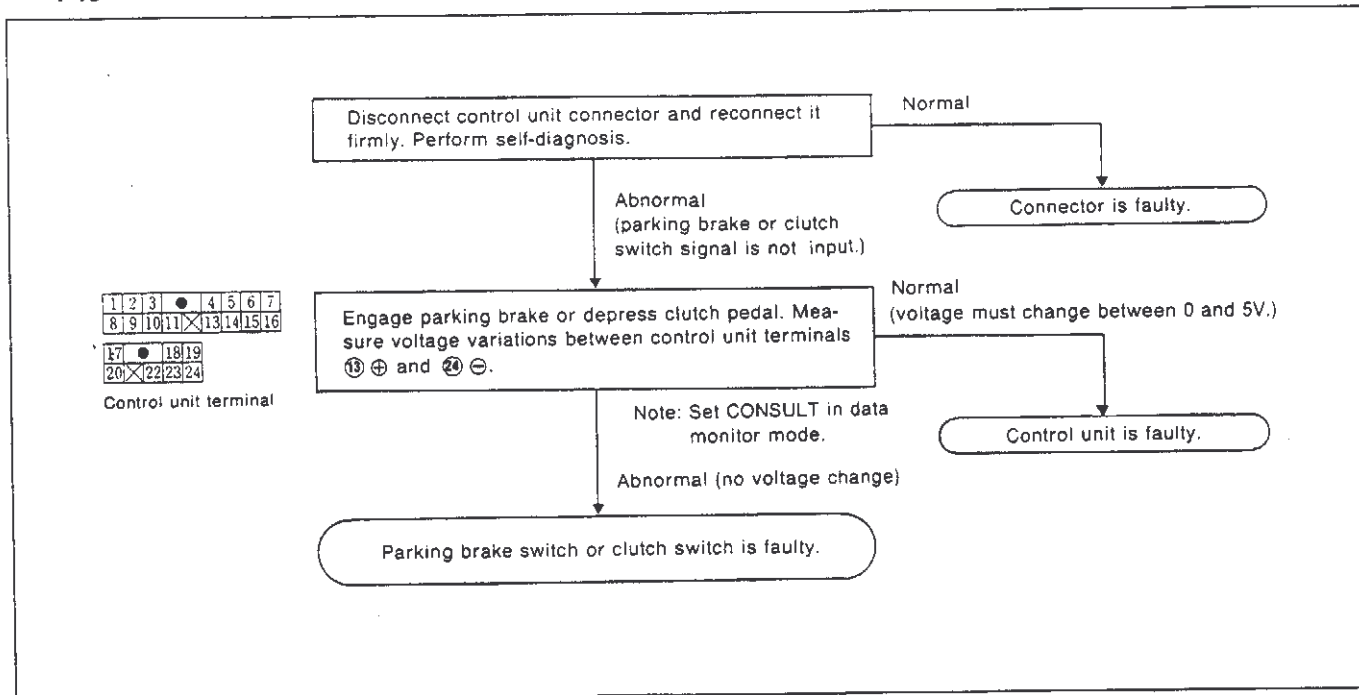

H. Inhibitor switch (A/T) or neutral switch (M/T) input is not present. [C Self-diagnosis items (9)]

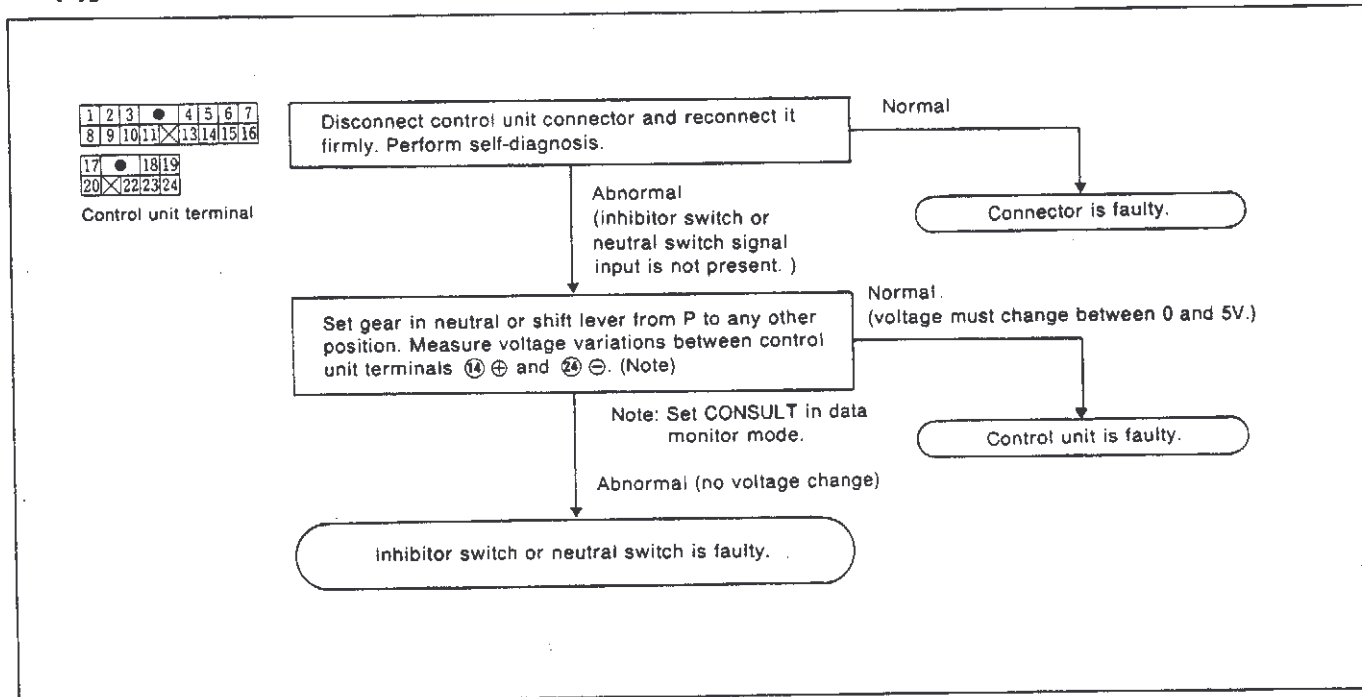

C12 SUPER HICAS

3. Trouble Diagnoses (Cont'd)

(5) Control unit inspection table

The standard value (voltage) measured with an analog tester in contact with the control unit terminal are shown below.

Terminal No.		Standard Value	Application
⊕	⊖		
①	⑩ or ⑭	—	Service support CLK input
②		—	Service support RX output
③		Ignition switch ON: Approx. 12V Ignition switch in other position: 0V	IGN power supply
④		Approx. 12V	Battery power supply
⑤		—	Number of ECCS revolution signals
⑥		Rear wheel rotating 0V ↔ greater than 5V (approx.) intermittent	Vehicle speed signal
⑦		Approx. 5V (neutral position)	Steering neutral position sensor
⑧		Solenoid resistance value 4 - 6Ω	Resistance of power steering solenoid
⑨		—	Service support TX output
⑪		Brake ON: Approx. 12V Brake OFF: 0V	Stop lamp switch signal
⑬		Parking brake engaged or clutch pedal depressed: Approx. 5V	(A/T) Parking brake signal (M/T) Clutch signal
⑭		Gear in N, or shift lever in any position other than parking: Approx. 5V	(A/T) Inhibitor signal (M/T) Neutral signal
⑮		Steering wheel turned 0 ↔ approx. 5V, intermittent	Steering angle sensor 1 signal
⑯			Steering angle sensor 2 signal
⑰		—	(Reserved for future switch input function.)
⑱		Solenoid resistance 13 - 17Ω	Fail-safe valve resistance
⑲		Ignition switch ON: Approx. 12V Ignition switch in other position: 0V	IGN power supply
⑳		—	HICAS warning lamp
㉑		Solenoid resistance 4 - 6Ω	HICAS solenoid (R.H.)
㉒		Solenoid resistance 4 - 6Ω	HICAS solenoid (L.H.)

C12 SUPER HICAS

3. Trouble Diagnoses (Cont'd)

3-2 HYDRAULIC SYSTEM TROUBLE DIAGNOSIS

(1) Diagnosis flowchart

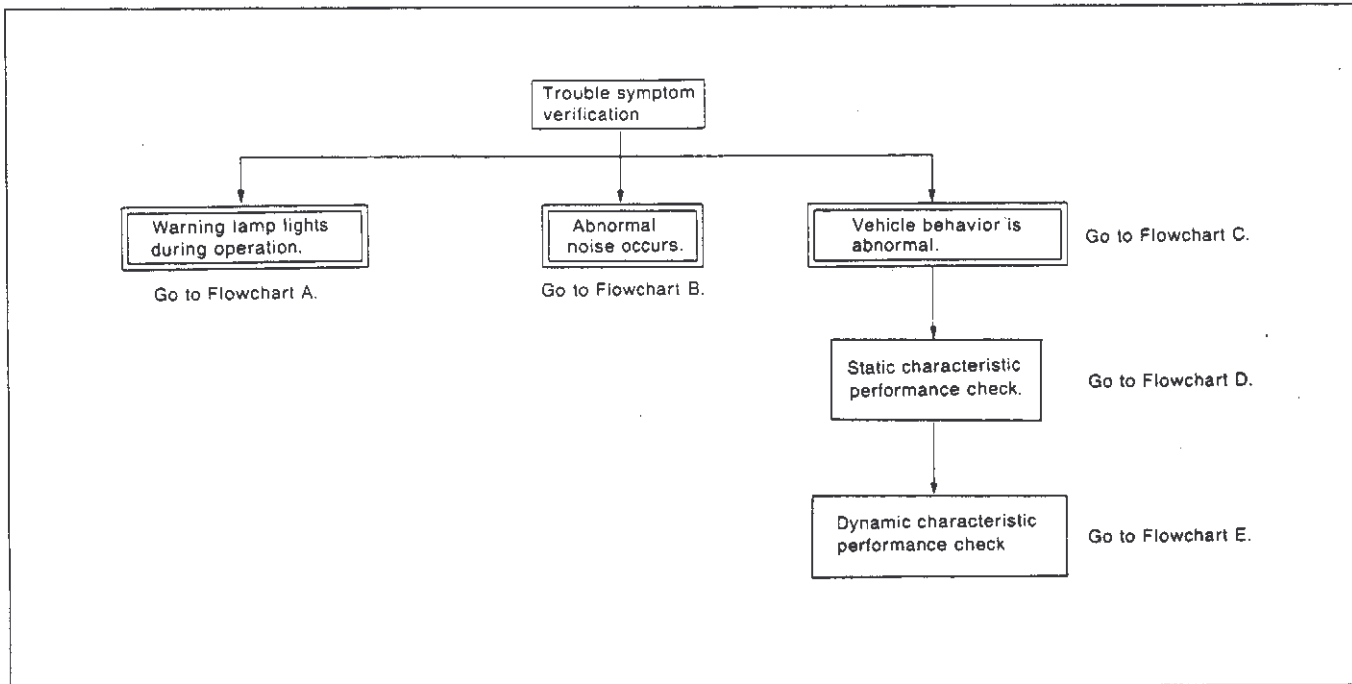

(2) Damage symptom flowchart

A. Warning lamp lights during operation

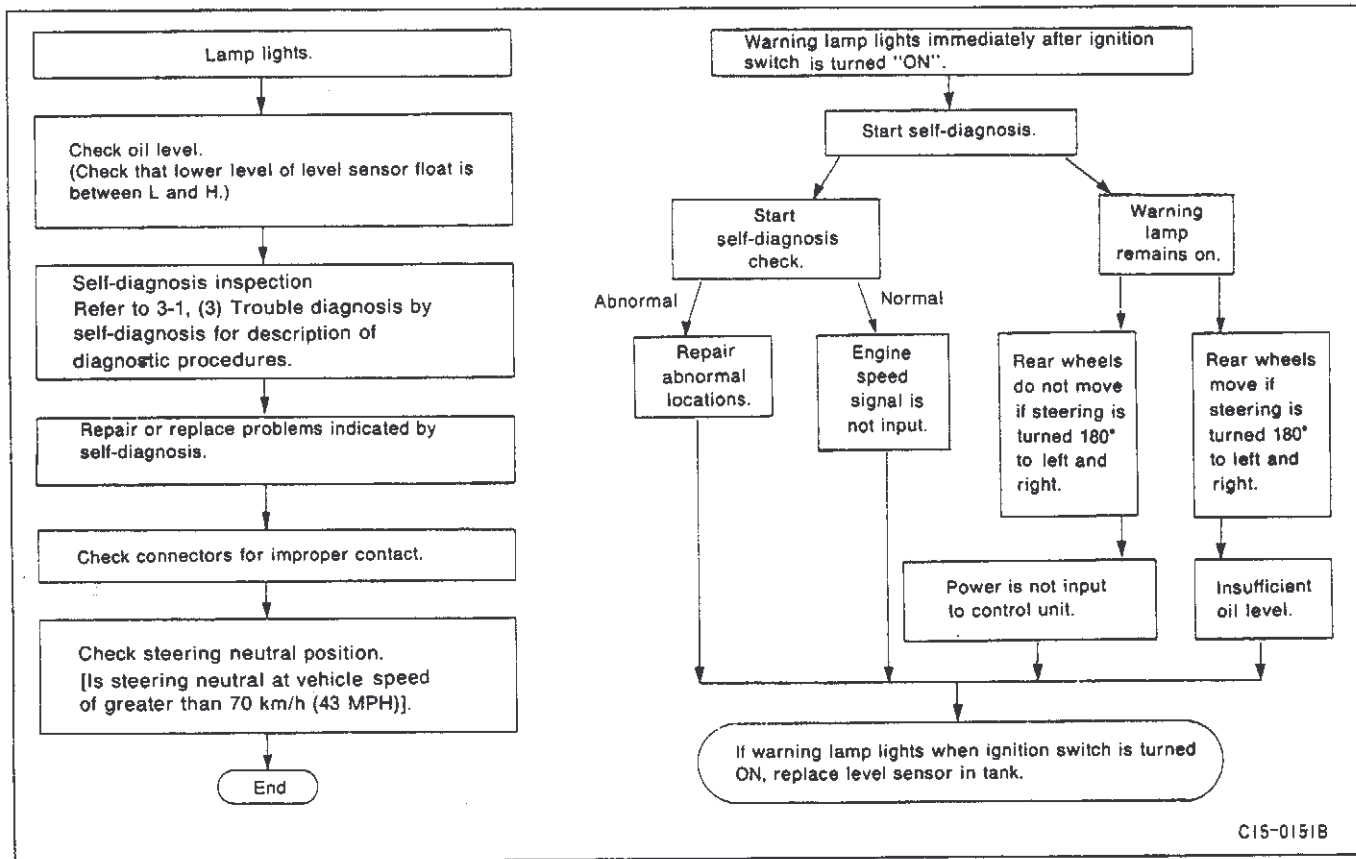

C15-0151B

C12 SUPER HICAS

3. Trouble Diagnoses (Cont'd)

B. Abnormal sound is present.

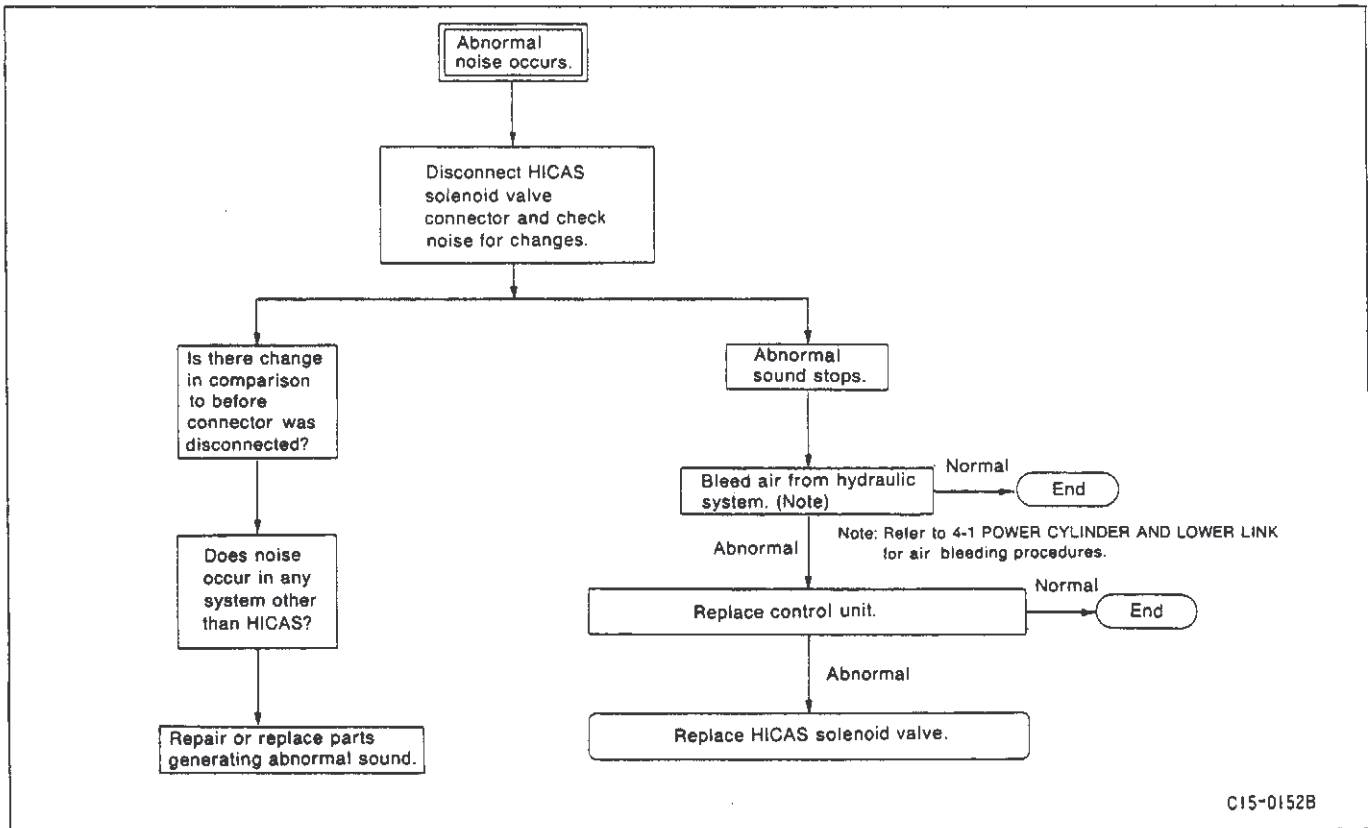

C12 SUPER HICAS

3. Trouble Diagnoses (Cont'd)

C. Vehicle behavior is abnormal.

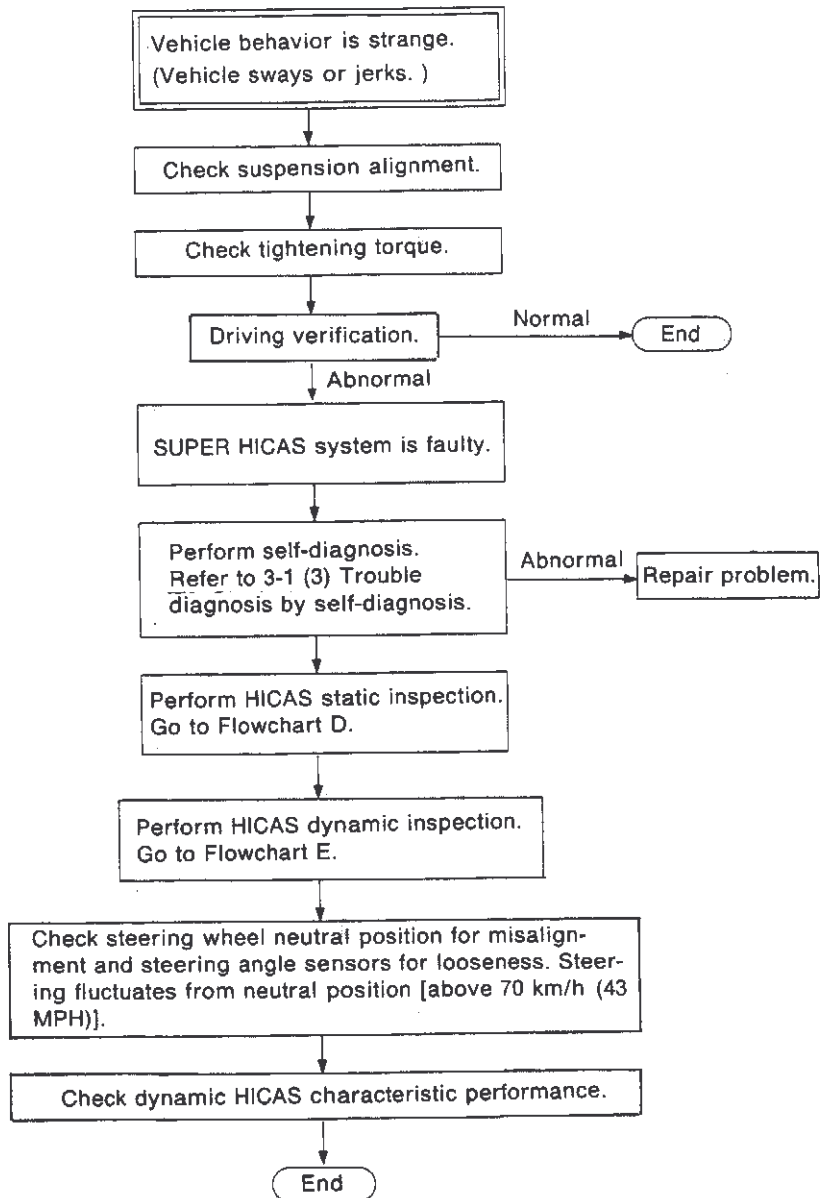

C15-0153B

C12 SUPER HICAS

3. Trouble Diagnoses (Cont'd)

D. Static HICAS characteristic performance check

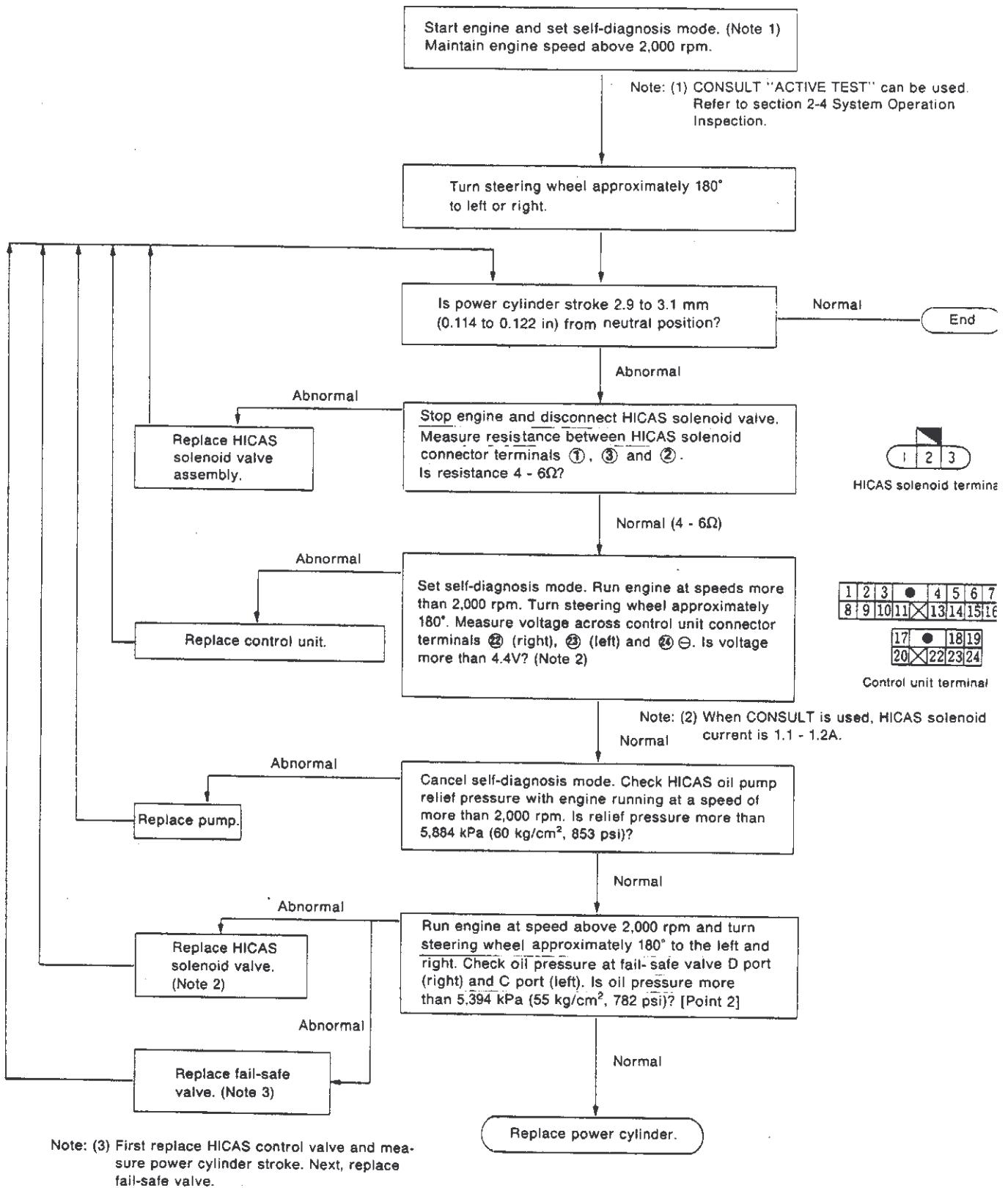

C12 SUPER HICAS

3. Trouble Diagnoses (Cont'd)

[Point 1] HICAS pump relief hydraulic inspection

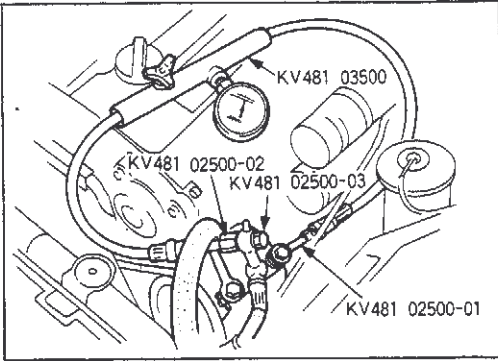

- Connect power steering pressure gauge adaptor (I-type joint) and power steering pressure gauge (special service tool) to HICAS outlet nozzle connector of power steering pump (tandem type).
- Set the power steering pressure gauge adaptor (flare joint) (special service tool) in HICAS high-pressure hose removed from power steering pump. (Note 1)

Raise vehicle.

Bleed air from hydraulic circuit.

Note 2: Refer to "Power steering gear and linkage removal and installation".

Open power steering pressure gauge valve fully and start engine. Move wheel to left and right to heat oil.

Note 1: If the valve is left fully closed while engine is running, the pressure in oil pump rises to relief pressure limit. Do not turn valve fully closed for extended periods because pressure rises to an abnormal level.

Relief pressure limit:
5,884 kPa (60 kg/cm², 853 psi)

Measure relief pressure when valve is fully closed and check that it does not exceed indicated specification limit.

Note 2: Valve must be opened after a maximum of 15 seconds. (If oil temperature rises, it may damage oil pump.)

Abnormal → Replace oil pump assembly.

Normal ↓

Remove power steering oil pressure gauge. Install high-pressure hose in oil pump outlet connector.

Bleed air from hydraulic system.

Relief pressure inspection - END

C15-0155B

C12 SUPER HICAS

3. Trouble Diagnoses (Cont'd)

[Point 2] HICAS solenoid valve and fail-safe valve inspection (relief pressure inspection)

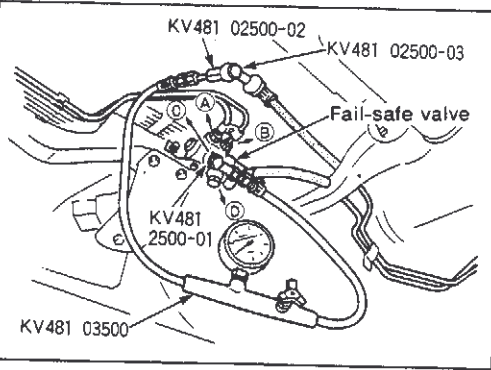

Raise vehicle.

- Connect power steering pressure gauge adaptor (I-joint) and power steering pressure gauge (special service tool) to ports (C) and (D) of fail-safe valve.
- Set the power steering pressure gauge adaptor (flare joint) (special service tool) in high-pressure hose removed from fail-safe valve. (Note 1)

Bleed air from hydraulic circuit.

Note 2: Refer to "4-1 POWER CYLINDER AND LOWER LINK" removal and installation procedures.

Open power steering pressure gauge valve fully and start engine. Move wheel to left and right to heat oil.

Measure relief pressure when valve is fully closed and check that it does not exceed indicated specification limit.

Relief pressure limit:
5,394 kPa (55 kg/cm², 782 psi)

Abnormal → First replace HICAS solenoid valve and measure power cylinder stroke. Next, replace fail-safe valve.

Normal → Remove power steering oil pressure gauge. Install high-pressure hose in oil pump outlet connector.

Bleed air from hydraulic system.

Relief pressure inspection - END

C12 SUPER HICAS

3. Trouble Diagnoses (Cont'd)

E. Dynamic characteristic inspection

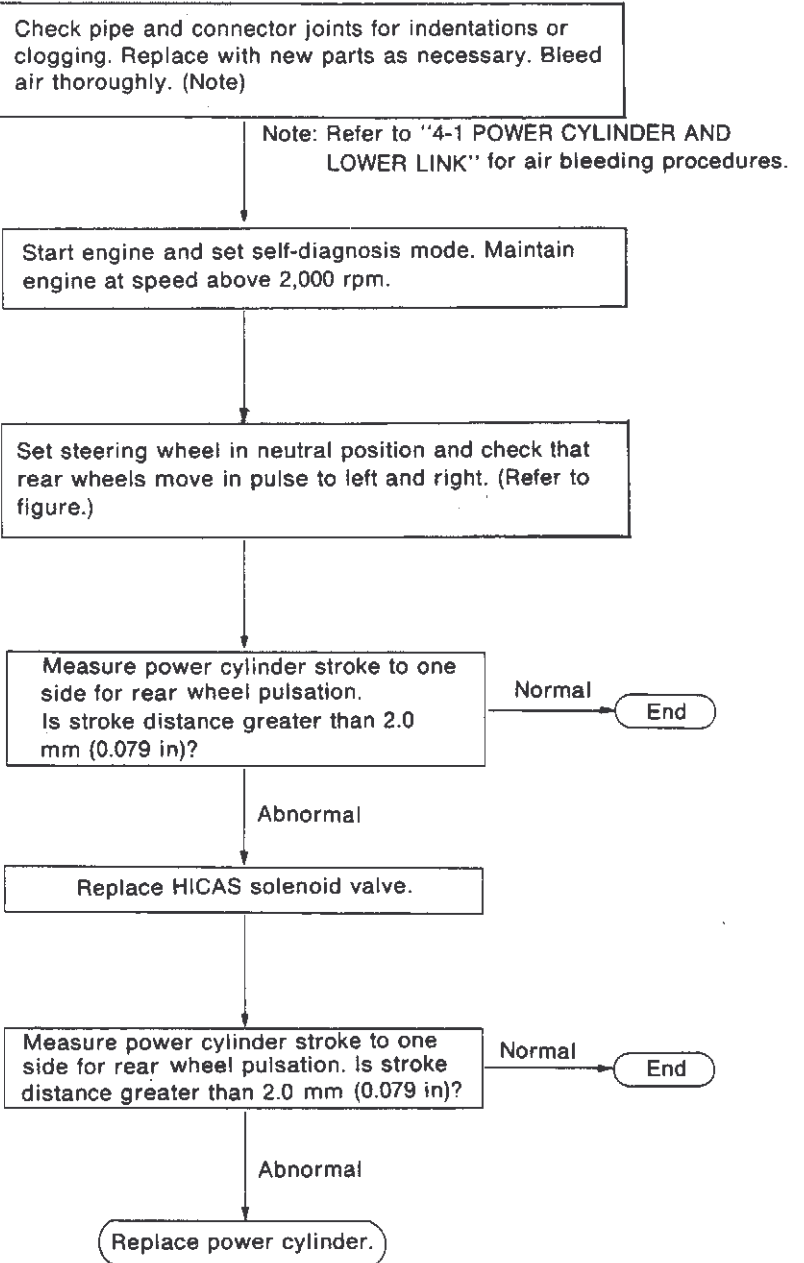
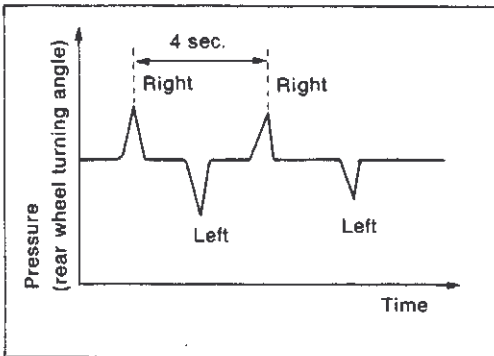

C12 SUPER HICAS

4. Removal and Installation, Assembly and Disassembly

4-1 POWER CYLINDER AND LOWER LINK

① Removal and installation

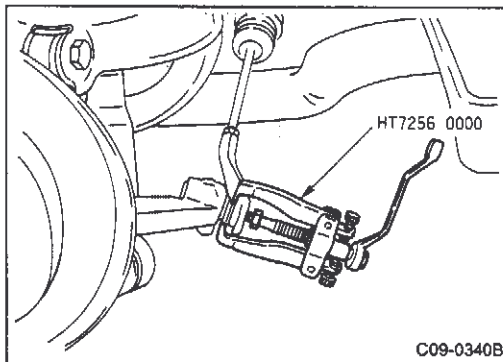
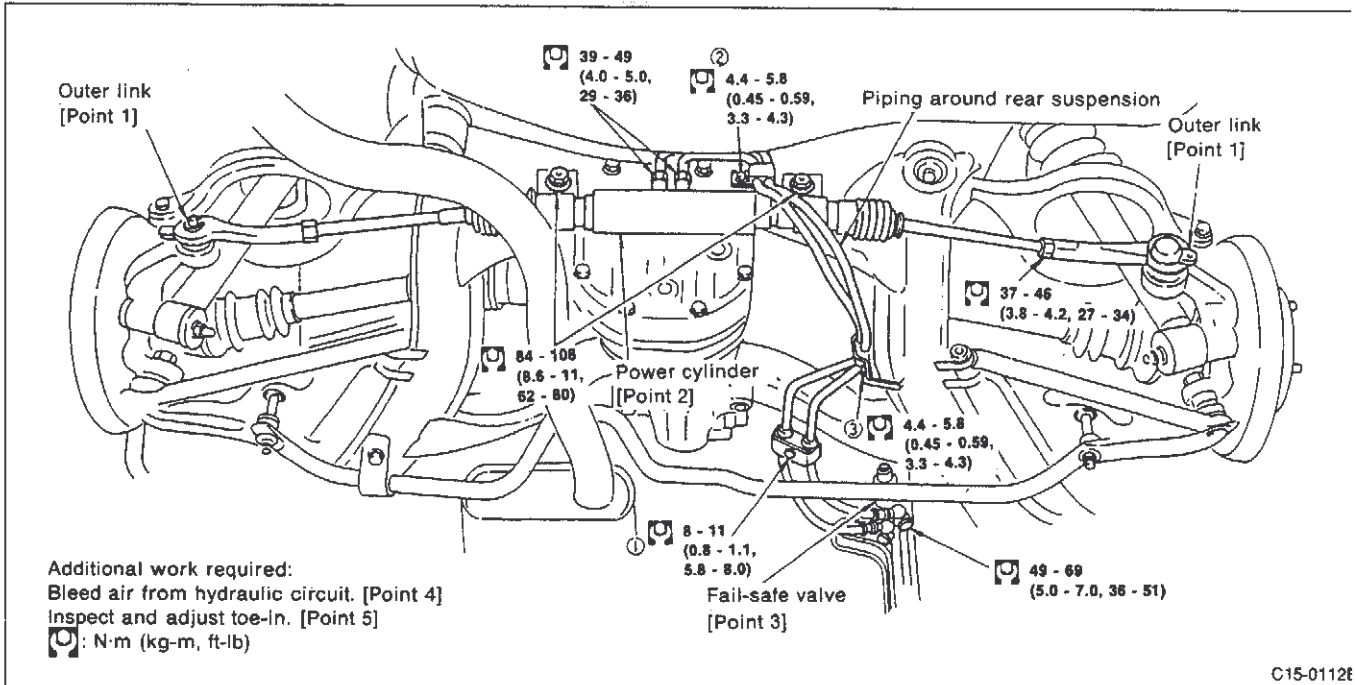

[Point 1] Outer link and ball joint separation

- Using Pitman arm puller (commercial service tool), separate power cylinder outer arm link and axle housing ball joint.

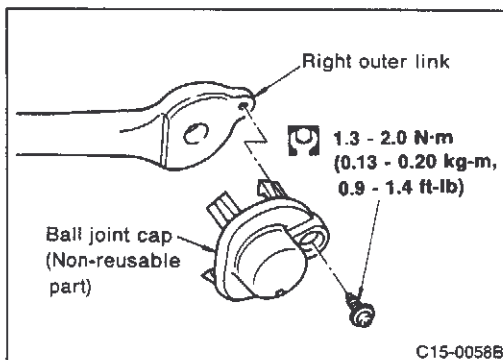

CAUTION:

- Install ball joint cap only in right outer link. (Refer to figure.)
- Replace non-reusable parts with new parts after disassembly.

C12 SUPER HICAS

4. Removal and Installation, Assembly and Disassembly (Cont'd)

[Point 2] Power cylinder assembly removal and installation

Removal

- Remove piping around power cylinder, outer link and rear suspension with assembly.

CAUTION:

When removing piping, cover openings so dust, debris and foreign matter cannot enter (especially in pipe connections).

Installation

- When replacing any of the piping surrounding the power cylinder, outer link and rear suspension, attach disassembled parts to suspension members.
- The piping removal and installation sequence is (1), (2), (3) as shown in figure on the preceding page.

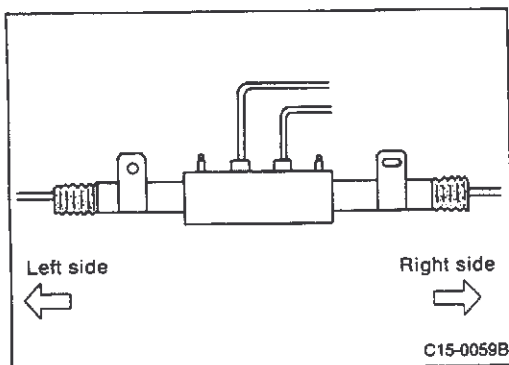

- When the power cylinder is installed on suspension member, wipe off all oil, debris and foreign matter from power cylinder side bracket and suspension member contact surfaces. Install bracket left side as reference to determine position of long hole on right side.

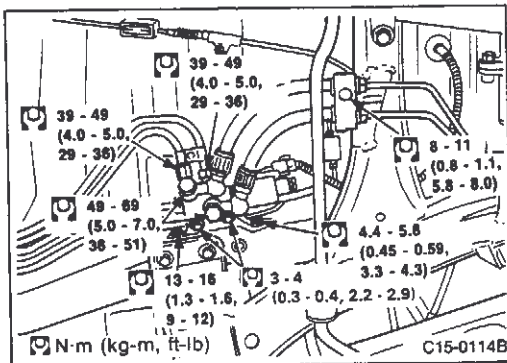

[Point 3] Fail-safe valve removal and installation

CAUTION:

- (1) Blow out pipes and ports with compressed air before installation to prevent entry of dirt, dust and foreign matter.
- (2) Perform operations in periphery of piping connections (especially in tube sheet removal and installation) with bare hands, being careful not to allow oil, dust or debris to adhere to the hands.
- (3) Always replace tube sheets that have been removed after every disassembly.

- After removing piping around rear suspension, always blow off piping and fail-safe valve with compressed air.
- Use pin punch (special service tool) to replace tube sheet as shown in figure on left, because scratches or cracks inside tube sheet in fail-safe valve can cause fluid leakage.

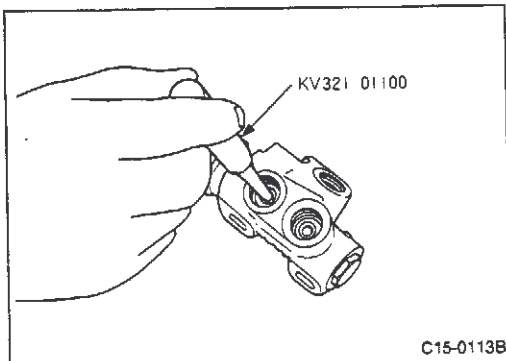

C12 SUPER HICAS

4. Removal and Installation, Assembly and Disassembly (Cont'd)

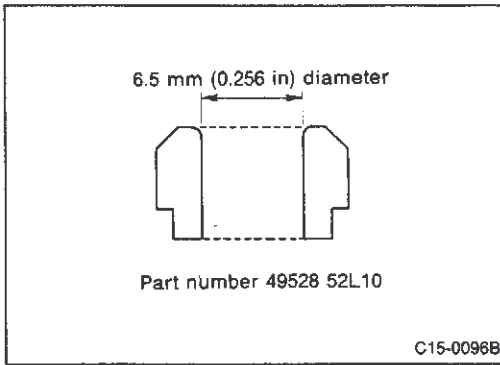

- Assemble tube sheet in port fail-safe valve as shown in figure.

C12 SUPER HICAS

4. Removal and Installation, Assembly and Disassembly (Cont'd)

[Point 4] Air bleeding hydraulic circuit

Air bleeding of HICAS system (power cylinder)

CAUTION:

Air bleeding of HICAS system must be performed after the air bleeding of power steering has been completed.

(1) When using CONSULT

- Connect CONSULT unit to vehicle diagnostic connector.
- Have a helper sit in driver's seat and raise vehicle.

Reference: Use a two-pole lift or a center pole lift so that the four wheels are free to rotate.

Start engine and maintain idle. Loosen left and right air bleeder valves above power cylinder and release oil until there are no more air bubbles.

Tighten left and right air bleeder valves.

- Start engine again.
- Touch "START" on CONSULT display. (Screen will change.)
- Touch "HICAS", "ACTIVE TEST", "SIMULATED DRIVE" and "START" in this order.

CAUTION: After touching "START", check that MAIN SIGNALS is displayed in reverse.

Touch "HIGH-SPEED SET".

* When engine is idling, turn steering wheel 180° from neutral position to right. Open air bleeder on right side of power cylinder gradually, bleed air from circuit and tighten bleeder again. Then return steering wheel to neutral position.

* When engine is idling, turn steering wheel 180° from neutral position to left. Open air bleeder on left side of power cylinder gradually, bleed air from circuit and tighten bleeder again. Then return steering wheel to neutral position.

- Touch "CANCEL" on CONSULT screen and turn ignition switch OFF.

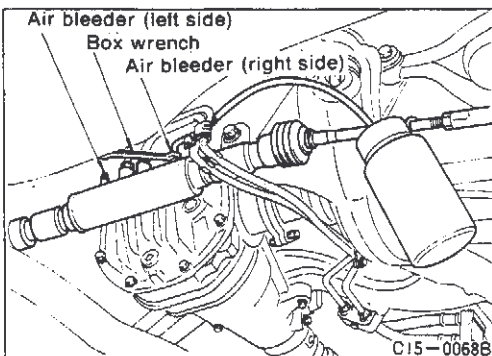

The procedures marked with an asterisk (*) should be repeated until air bubbles no longer occur. Fill reservoir during operation to prevent fluid level from lowering to suction inlet level.

C15-041B

C12 SUPER HICAS

4. Removal and Installation, Assembly and Disassembly (Cont'd)

(2) When CONSULT is not used



Have a helper sit in driver's seat and raise vehicle.

Reference: Use a two-pole lift or a center pole lift so that the four wheels are free to rotate.

Start engine and maintain idle. Loosen left and right air bleeder valves above power cylinder and release oil until there are no more air bubbles.

Tighten left and right air bleeder valves.

Input self-diagnosis item.

- Turn ignition switch OFF.
- Turn steering wheel from neutral to left and right (at least 20° in each direction) 5 times or more while depressing brake pedal at least 5 times, all within 10 seconds after ignition switch has been turned "ON".

Set steering wheel in neutral position (within 10° left and right), and check that both rear wheels are being steered respectively.

* When engine is idling, turn steering wheel 180° from neutral position to right. Open air bleeder on right side of power cylinder gradually, bleed air from circuit and tighten bleeder again. Then return steering wheel to neutral position.

* When engine is idling, turn steering wheel 180° from neutral position to left. Open air bleeder on left side of power cylinder gradually, bleed air from circuit and tighten bleeder again. Then return steering wheel to neutral position.

Turn ignition switch OFF to cancel self-diagnosis.

The procedures marked with an asterisk (*) should be repeated until air bubbles no longer occur. Fill reservoir during operation to prevent fluid level from lowering to suction inlet level.

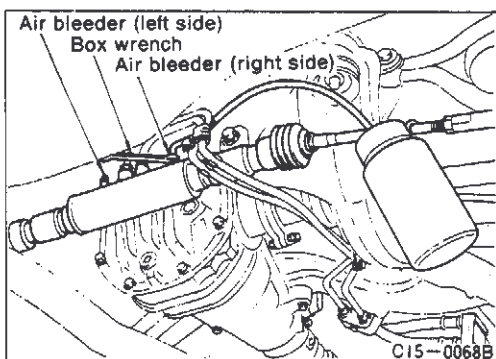

C15-0158B

[Point 5] Toe-in distance inspection and adjustment

- After installing power cylinder and lower link assembly perform toe-in inspection and check that distance is within specification.
- If value is outside specification, adjust toe-in.

C12 SUPER HICAS

4. Removal and Installation, Assembly and Disassembly (Cont'd)

② Assembly and disassembly

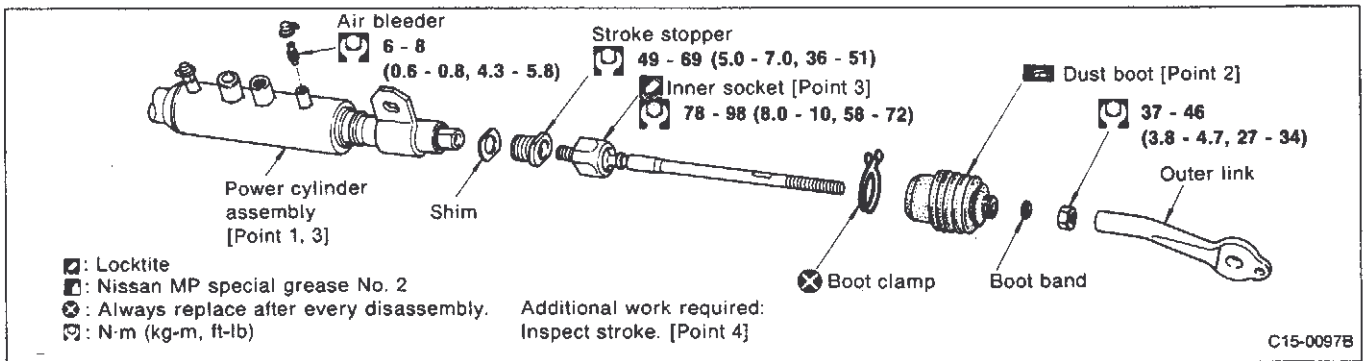

[Point 1] Power cylinder disassembly

CAUTION:

- Blow off piping and ports before operation to prevent dust and foreign matter from entering area.
 - Perform operations in periphery of piping connections (especially in tube sheet removal and installation) with bare hands, being careful not to allow oil, dust or debris to adhere to the hands.
- Do not disassemble any parts other than those shown in above figure (disassembly figure). Only disassemble pipes and inner sockets.

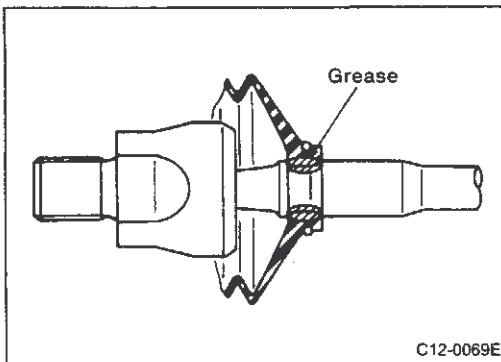

[Point 2] Dust boot installation

- Coat contact surfaces and boot installation groove with grease (Nissan MP special grease No. 2).

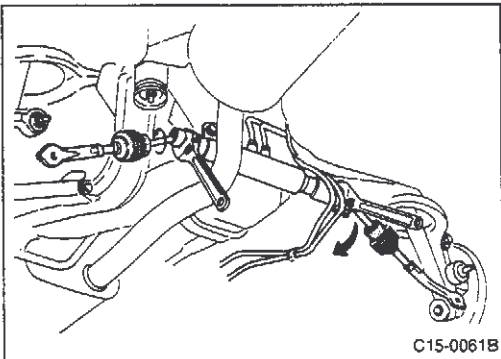

[Point 3] Power cylinder inner socket removal and installation

- Remove and install inner socket with power cylinder assembly installed in vehicle.

Removal

- Separate tie-rod from rear axle.
- Remove boot clamp from dust boot. Move left and right dust boots to outer link side.
- Attach tool to socket of left and right inner ball joints. Turn in direction that loosens both sides and remove loosened lower link assembly.

C12 SUPER HICAS

4. Removal and Installation, Assembly and Disassembly (Cont'd)

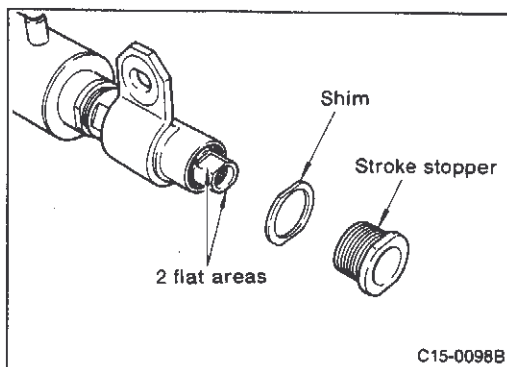

- Loosen and remove stroke stopper from removed lower link assembly.

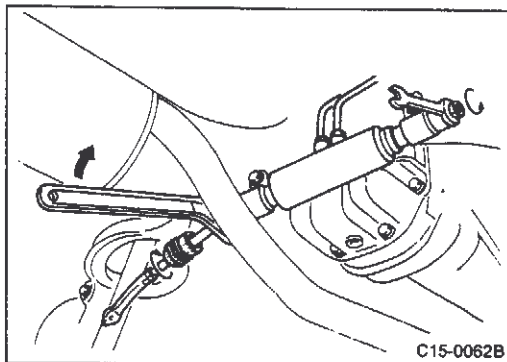

- Attach wrench to the two flat areas on rod end from side stroke stopper that was removed from and turn to tighten. Loosen lower link assembly on opposite side and remove.

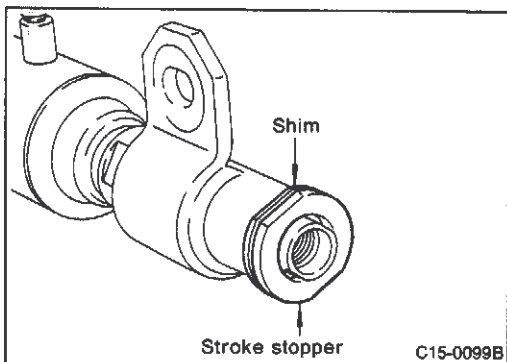

Installation

- Install stroke stopper and shim on assembled side of lower link assembly.

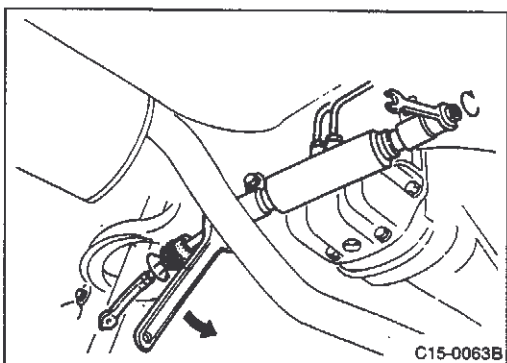

- Apply a coat of Loctite to inner ball joint screw. Attach wrench to the two flat surfaces on piston rod opposite from assembly side and turn to tighten. Install lower link assembly.

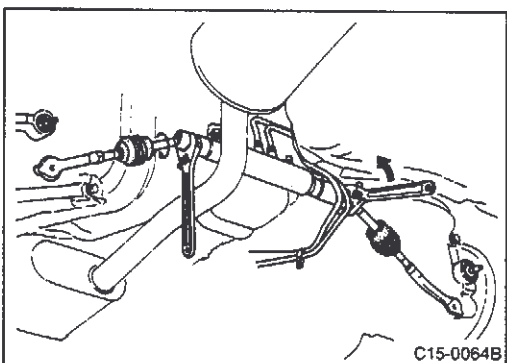

- After installing stroke stopper and shim on opposite side, install lower link assembly. Attach wrench to inner ball joint on opposite side and turn to tighten. Tighten to specified torque.

Inner socket tightening torque:

78 - 98 N·m (8.0 - 10 kg-m, 58 - 72 ft-lb)

C12 SUPER HICAS

4. Removal and Installation, Assembly and Disassembly (Cont'd)

[Point 4] Stroke inspection

- After assembling shim and stroke stopper, check clearance between inner socket and stroke stopper.
Clearance: 3 ± 0.1 mm (0.118 ± 0.004 in)

C12 SUPER HICAS

4. Removal and Installation, Assembly and Disassembly (Cont'd)

[Point 1] HICAS solenoid valve piping removal and installation

CAUTION:

- (1) Handle pipes with bare hands and pay attention to prevent dust or foreign matter from adhering.
- (2) Be careful not to install pipes in incorrect location or sequence during assembly.

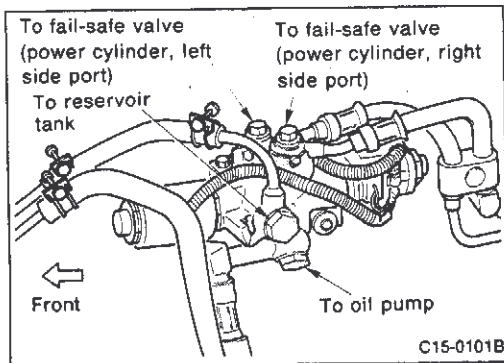

Removal

- Remove HICAS solenoid valve connector and pipe clamp bracket.
- Remove power steering fluid from vehicle side centralized pipe connection.
- Remove HICAS solenoid valve pump port, tank port and power cylinder port on right side and flare nuts and union bolts on left side. Remove bolts from HICAS solenoid valve mount.

CAUTION:

- (1) Never disassemble HICAS solenoid valve or fail-safe valve. This part cannot be disassembled because if the lock nuts on the fixed part of the HICAS valve solenoid are loosened, the pressure adjustment distance will vary.
- (2) Cover caps of removed pipes and hoses with plugs to prevent dust and foreign matter from entering.

Installation

- Temporarily tighten flare nuts and union bolts and tighten HICAS solenoid valve mount bolts. Secure tube clamp bracket and tighten port union bolts.

[Point 2] Fluid tank fluid level inspection

- Refer to "2. On-vehicle Inspection and Adjustment" for inspection procedures.

[Point 3] Air bleeding fluid circuit

- Refer to "4-1 POWER CYLINDER AND LOWER LINK ① Removal and installation" for a description of air bleeding procedures for HICAS system.

C12 SUPER HICAS

4. Removal and Installation, Assembly and Disassembly (Cont'd)

(2) Power steering pump removal and installation, assembly and disassembly

Assembly and disassembly precautions

- ① If oil pump and tank assembly and disassembly is required, perform the following procedures for removal and installation from vehicle.
 - Indicate oil leakage locations with a white marking pen.
 - Remove oil and cap openings.
 - Loosen pulley nut before loosening belts. Tighten tension on all belts before installation.
- ② Attachment preparation
 - Prepare the following attachments.

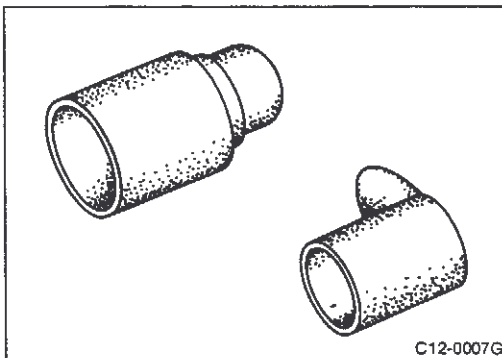
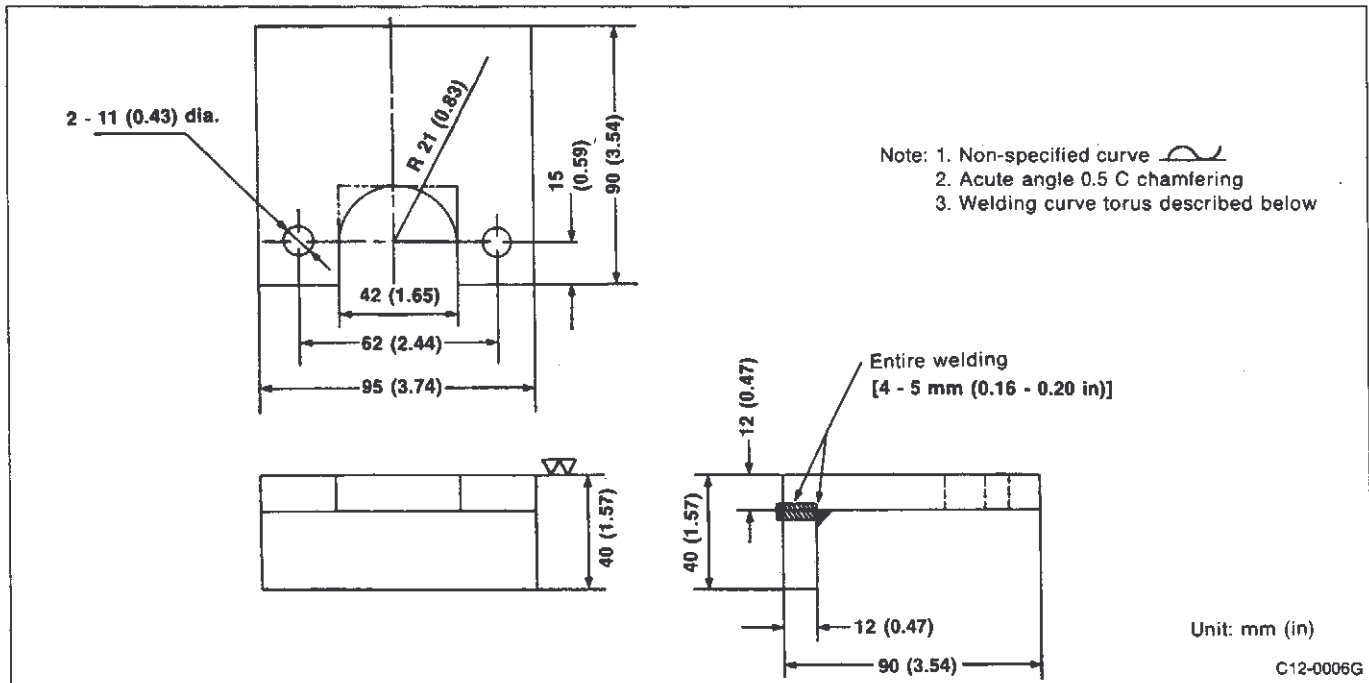

- Wash off grease on oil pump with white gasoline. Cover openings in outlet port, return ports to prevent white gasoline from entering. Be careful not to drop white gasoline on oil seal of drive shaft.
- Never reuse any O-ring, oil seal, snap ring, or washer (copper). Always replace with new part after every use. (New parts are contained in repair kits.)
- Replace entire assembly if front and rear housing, drive shafts, rotor, cam and flow control valve are scratched, dented or scored.

C12 SUPER HICAS

4. Removal and Installation, Assembly and Disassembly (Cont'd)

③ Power steering pump disassembly (Model 05U00)

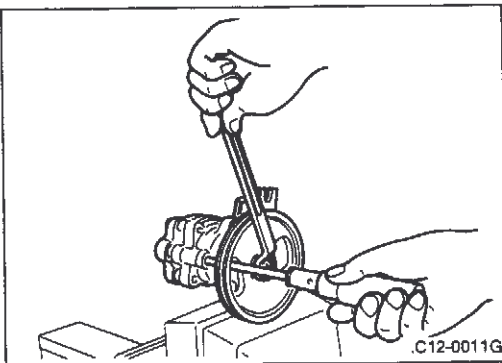
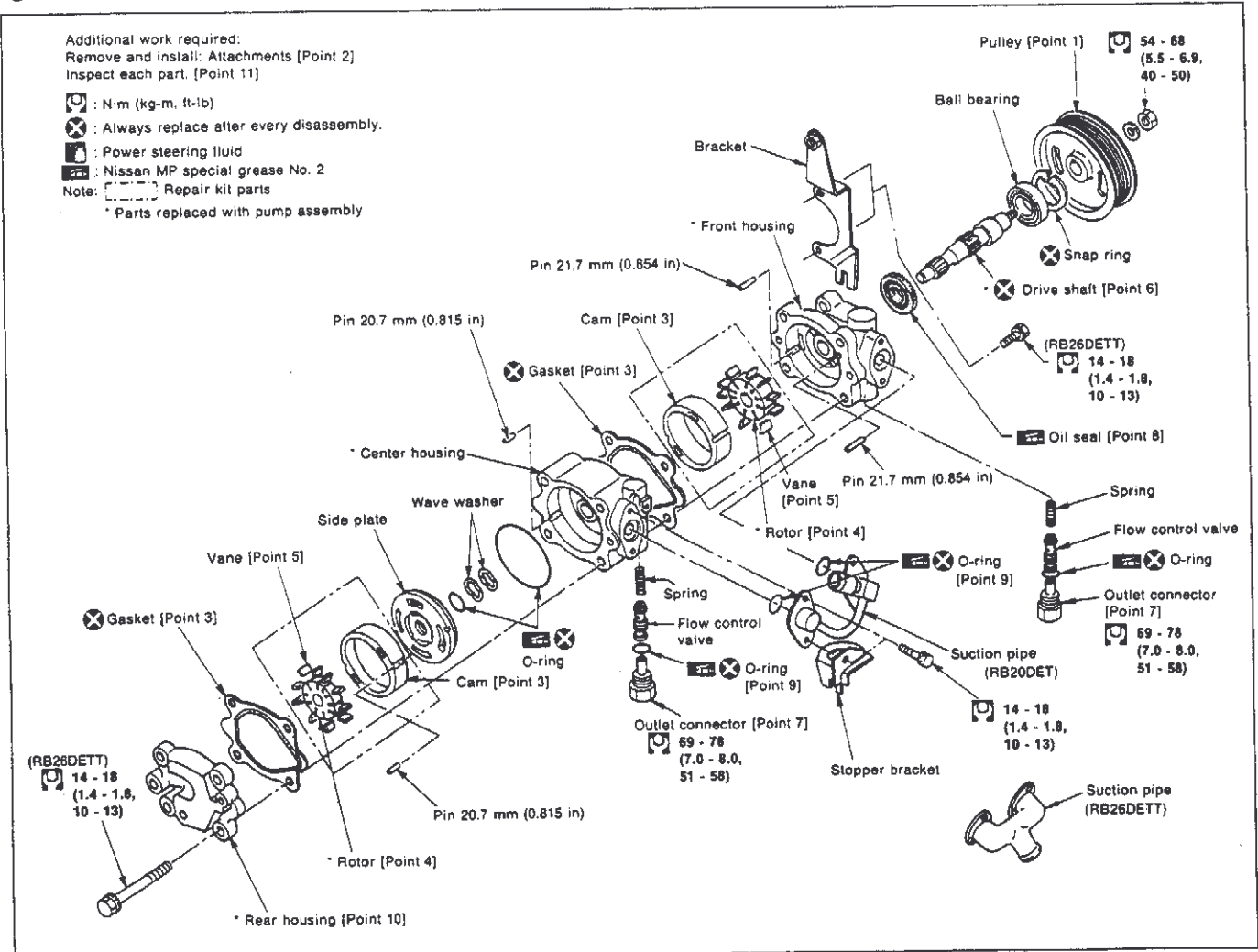

[Point 1] Pulley removal and installation

- Loosen in unit if pulley nut cannot be loosened when pump is installed in vehicle.
- Secure bracket in vise.
- Place Phillips head screwdriver in pulley hole and through front housing bolt hole to secure pulley and loosen pulley nut.
- Inscribe mating marks on front side of pulley to prevent incorrect pulley alignment and then remove pulley.

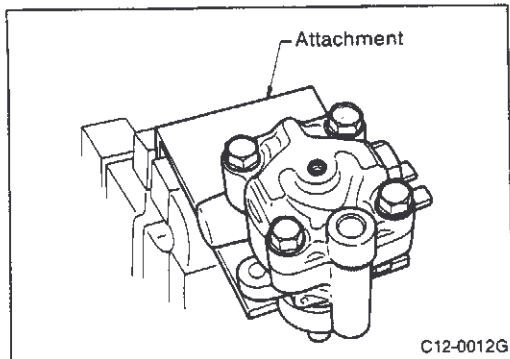

[Point 2] Attachment installation

- Secure attachment in vise.
- Install front housing in attachment.

C12 SUPER HICAS

4. Removal and Installation, Assembly and Disassembly (Cont'd)

[Point 3] Cam and gasket installation

- Install the thicker side of cam ($t_1 > t_2$) facing front side.

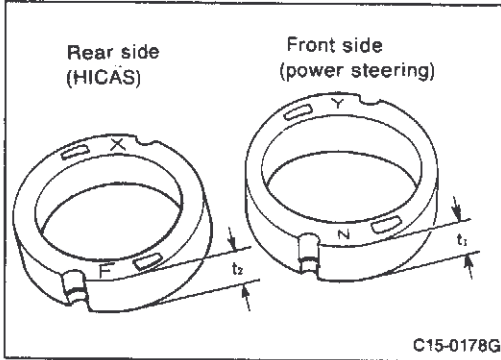

- Check gasket alignment, and install one each at front housing and center housing and center housing and rear housing.

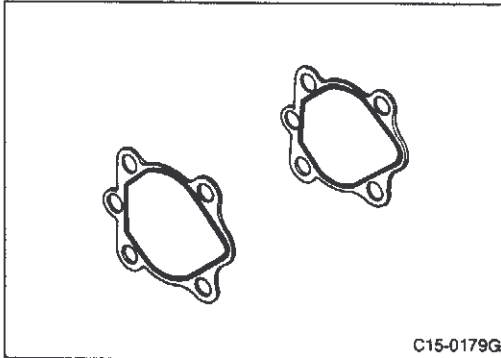

[Point 4] Rotor installation

- Install rotor so the chamfered side of spline is faces rear housing side and side without chamfering faces front housing side. (Otherwise, install rotor so the punch mark side faces rear housing side and side without punch mark faces front housing side.)

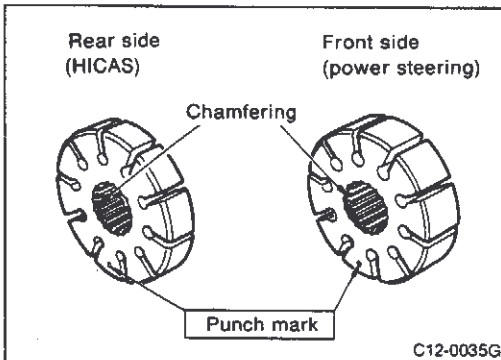

[Point 5] Vane installation

- Assemble so rounded end faces cam surface.

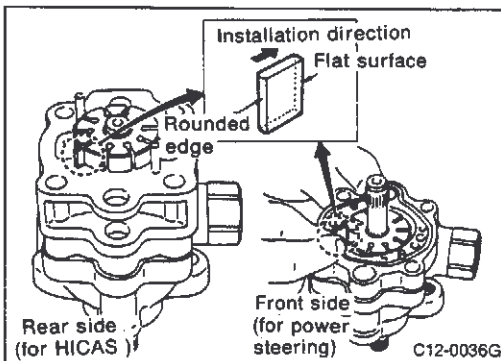

[Point 6] Drive shaft removal and installation

- Pull shaft straight out slowly to remove.

CAUTION:

Be careful not to scratch bushing inside front cover or oil seal.

- Coat drive shaft with power steering fluid and press in slowly to install.
- Press into bottom, pull out 15 mm (0.59 in) and then slowly press in again.

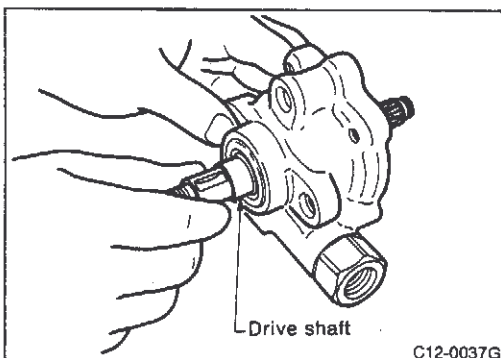

C12 SUPER HICAS

4. Removal and Installation, Assembly and Disassembly (Cont'd)

CAUTION:

Replace oil pump assembly carefully to prevent scratching drive shaft and bushing.

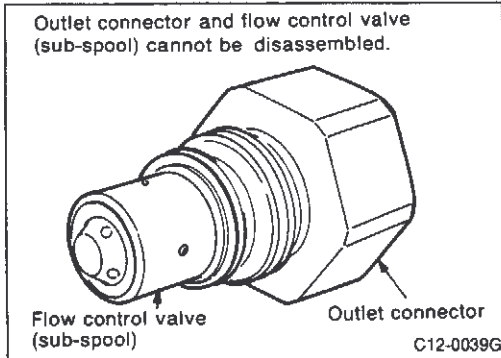

[Point 7] Outlet connector removal

- Outlet connector is installed inside front control valve (sub-spool). Be careful not to drop or deform during removal.
- Do not disassemble outlet connector and flow control valve.

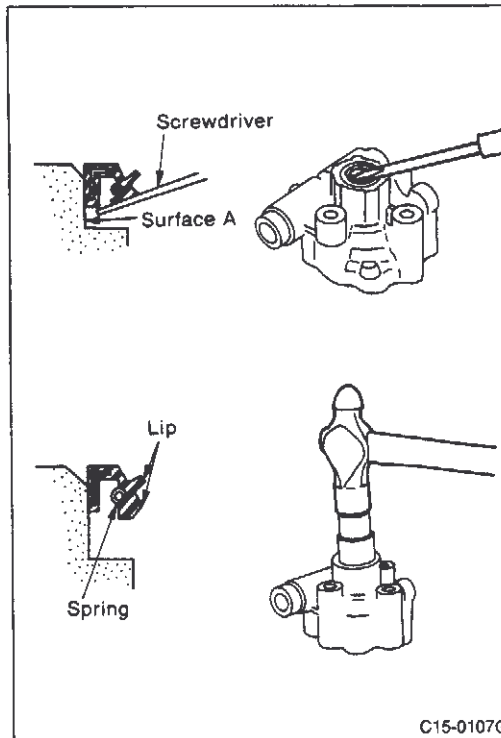

[Point 8] Oil seal removal and installation

- Pay attention not to scratch sliding surface of oil seal during removal and installation.
- Use a screwdriver wrapped in tape to remove seal.

CAUTION:

- (1) Insert screwdriver in position shown in figure.
- (2) Do not scratch surface A (oil seal installation mating surface) shown in figure.

If this surface is scratched, replace entire oil pump assembly.

- Use a taped 22-mm box wrench for installation.

CAUTION:

Check that oil seal is positioned straight and lightly tap seal into end of front housing with hammer to install.

- After installation, apply a thin coat of Nissan MP special grease No. 2 around oil seal lip.
- Touch spring with finger to check that it is installed in correct position.

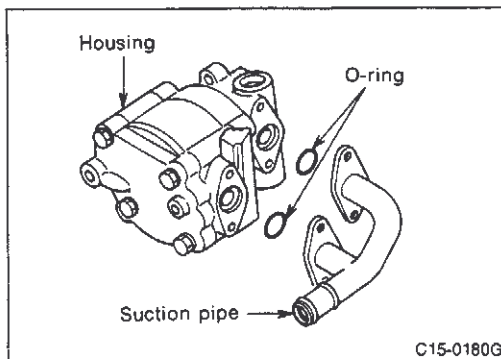

[Point 9] O-ring installation

- Coat O-rings with power steering fluid.
- Install O-rings inside groove in housing.

C12 SUPER HICAS

4. Removal and Installation, Assembly and Disassembly (Cont'd)

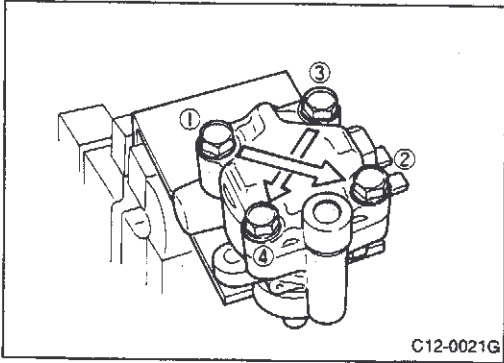

[Point 10] Rear housing installation

- Secure front housing in attachment. Position cam, rotor center housing, cam, rotor and rear housing and install.
- Tighten bolts in diagonal sequence. First tighten each bolt to approximately half of specified torque and then tighten again to final torque.

Rear housing installation bolt tightening torque:

RB26DETT

31 - 42 N·m (3.2 - 4.3 kg·m, 23 - 31 ft·lb)

[Point 11] Inspection

- Do not reuse removed rubber parts (O-rings, oil seal and snap rings) or washers (copper). (Replace with parts in repair kit.)
- Replace pump assembly if the following parts are scratched or damaged.
 - ① Front housing and center housing mating surfaces
 - ② Rear housing and cam center housing mating surfaces
 - ③ Front housing oil seal
 - ④ Flow control valve
 - ⑤ Drive shaft
 - ⑥ Rotor

SECTION BF

CONTENTS

D BODY	
D1 BODY	BF- 2
1. Body Construction	BF- 2
2. Sealing	BF- 3
D2 BODY EXTERIOR	BF-10
1. Bumper	BF-10
2. Grille	BF-15
3. Front Fender	BF-16
4. Molding	BF-17
5. Window Glass	BF-22
6. Outside Mirror	BF-24
7. Spoilers	BF-28
8. Drafter	BF-29
9. Center Mudguard and Chipping Protector	BF-30
D3 OPEN-CLOSE MECHANISM	BF-31
1. Hood	BF-31
2. Door	BF-32
2-1 Fitting standard and adjustment	BF-32
2-2 Door assembly removal and installation	BF-33
2-3 Front door trim removal and installation	BF-34
2-4 Front door lock and remote control removal and installation	BF-35
2-5 Front door window and regulator removal and installation	BF-37
2-6 Power door lock trouble diagnosis	BF-41
2-7 Power window trouble diagnosis	BF-44
3. Trunk Lid	BF-51
D4 BODY INTERIOR	BF-53
1. Instrument Panel	BF-53
2. Interior Trim and Equipment	BF-62
3. Seat	BF-66
4. Seat Belts	BF-69

D1 BODY

1. Body Construction

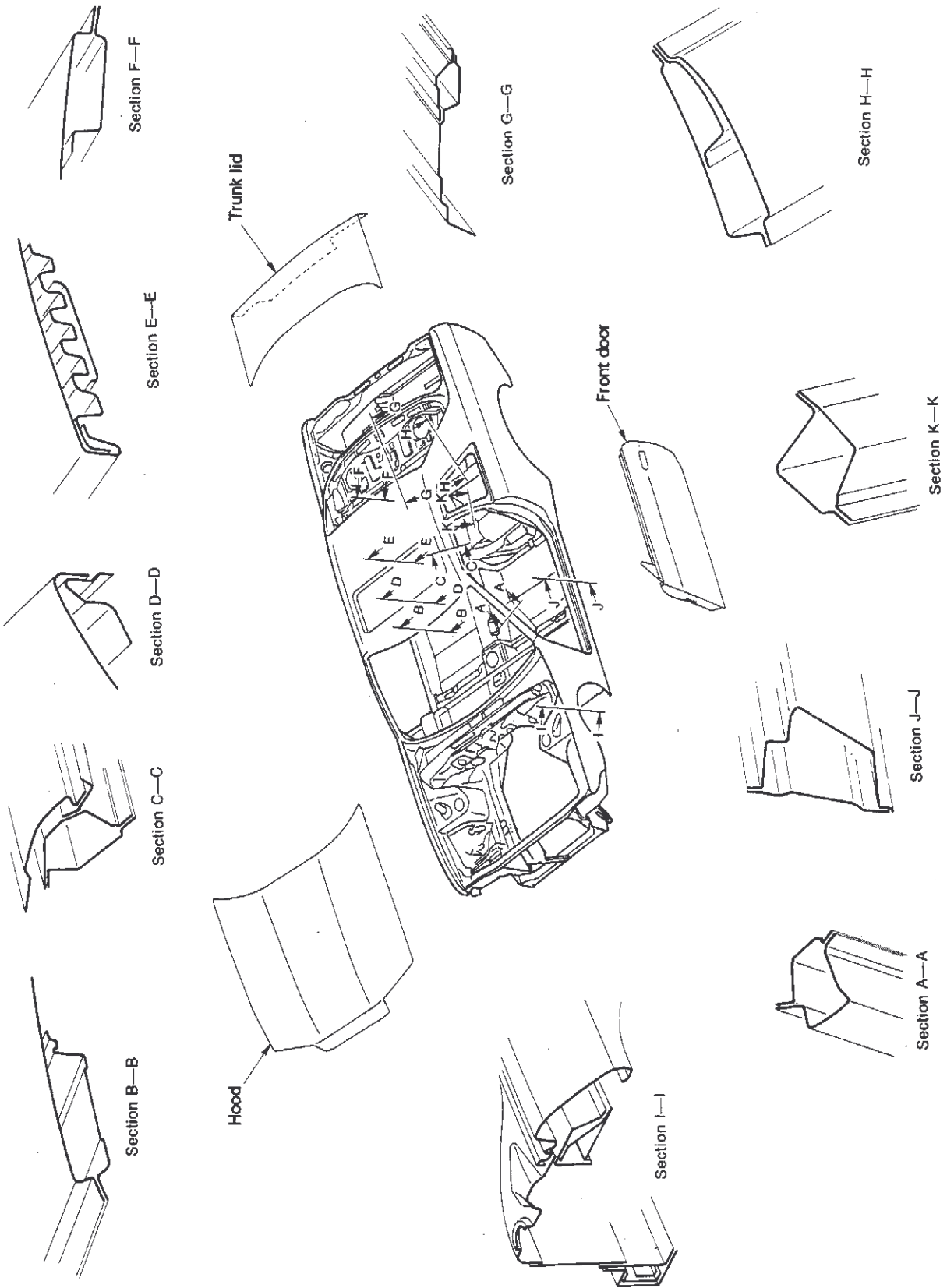

2-door Sports Coupe Body Construction

D1 BODY

2. Sealing

2-1 WEATHERSTRIPS

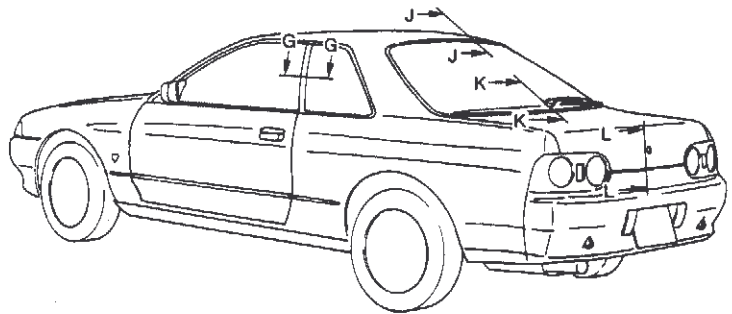
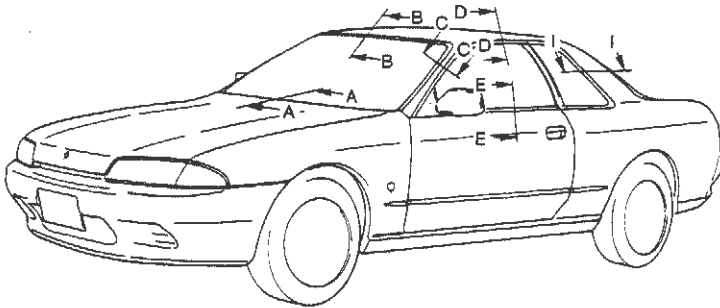

2-door Sports Coupe

D1 BODY

2. Sealing (Cont'd)

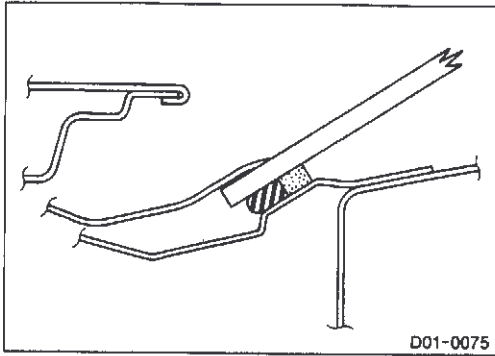

Section A—A

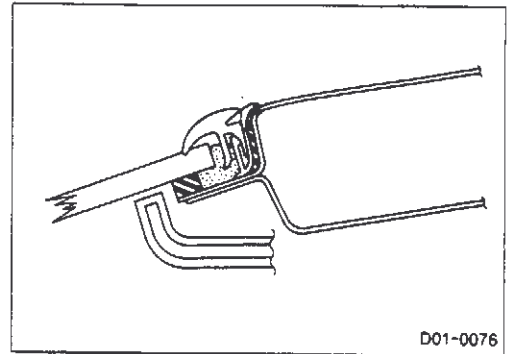

Section B—B

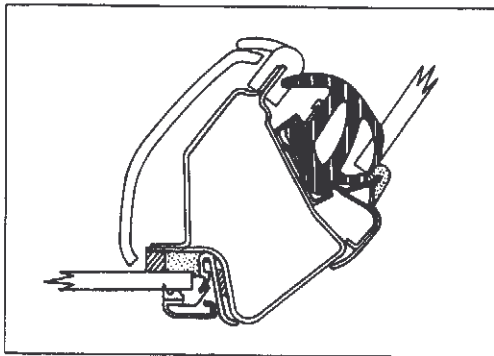

Section C—C

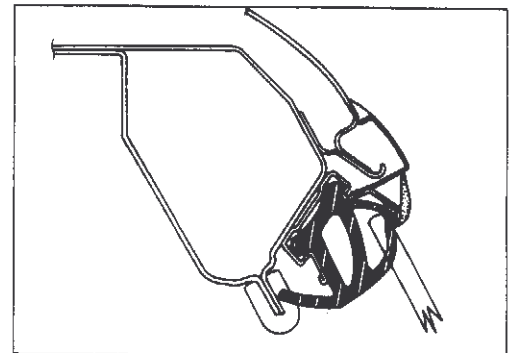

Section D—D

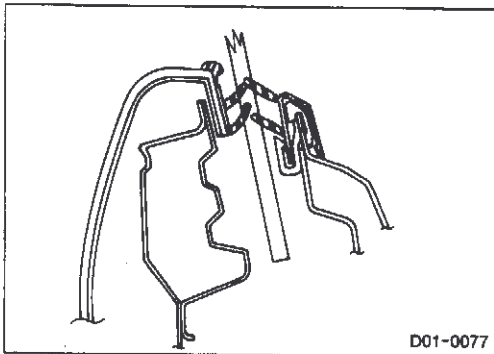

Section E—E

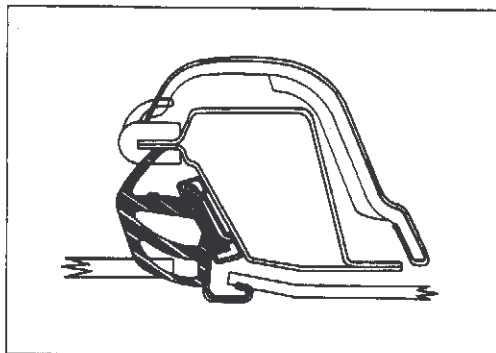

Section G—G

D1 BODY
2. Sealing (Cont'd)

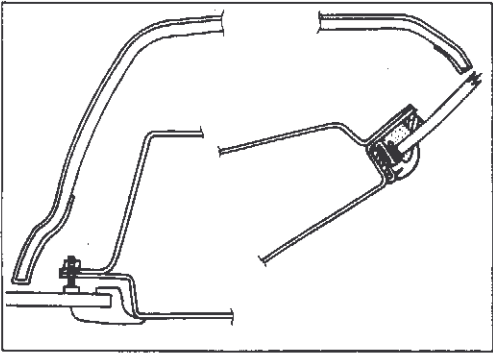

Section I—I

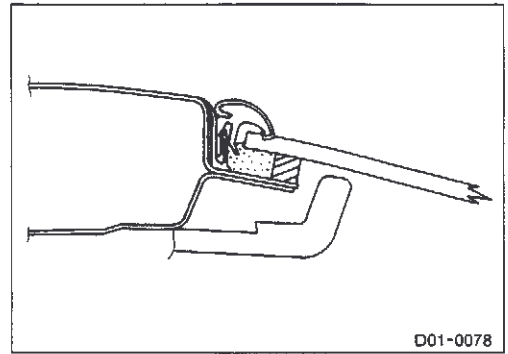

D01-0078

Section J—J

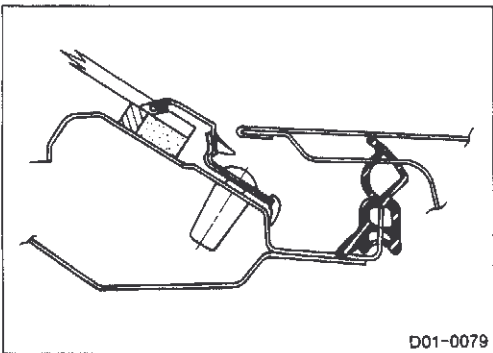

D01-0079

Section K—K

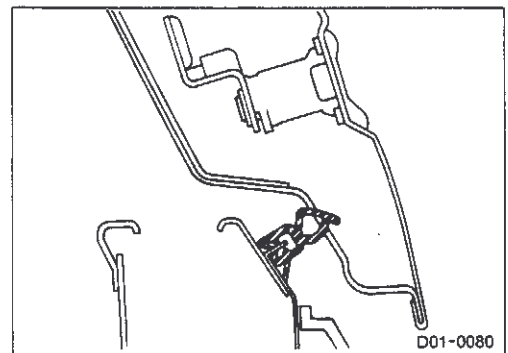

D01-0080

Section L—L

D1 BODY

2. Sealing (Cont'd)

2-2 BODY SEALING

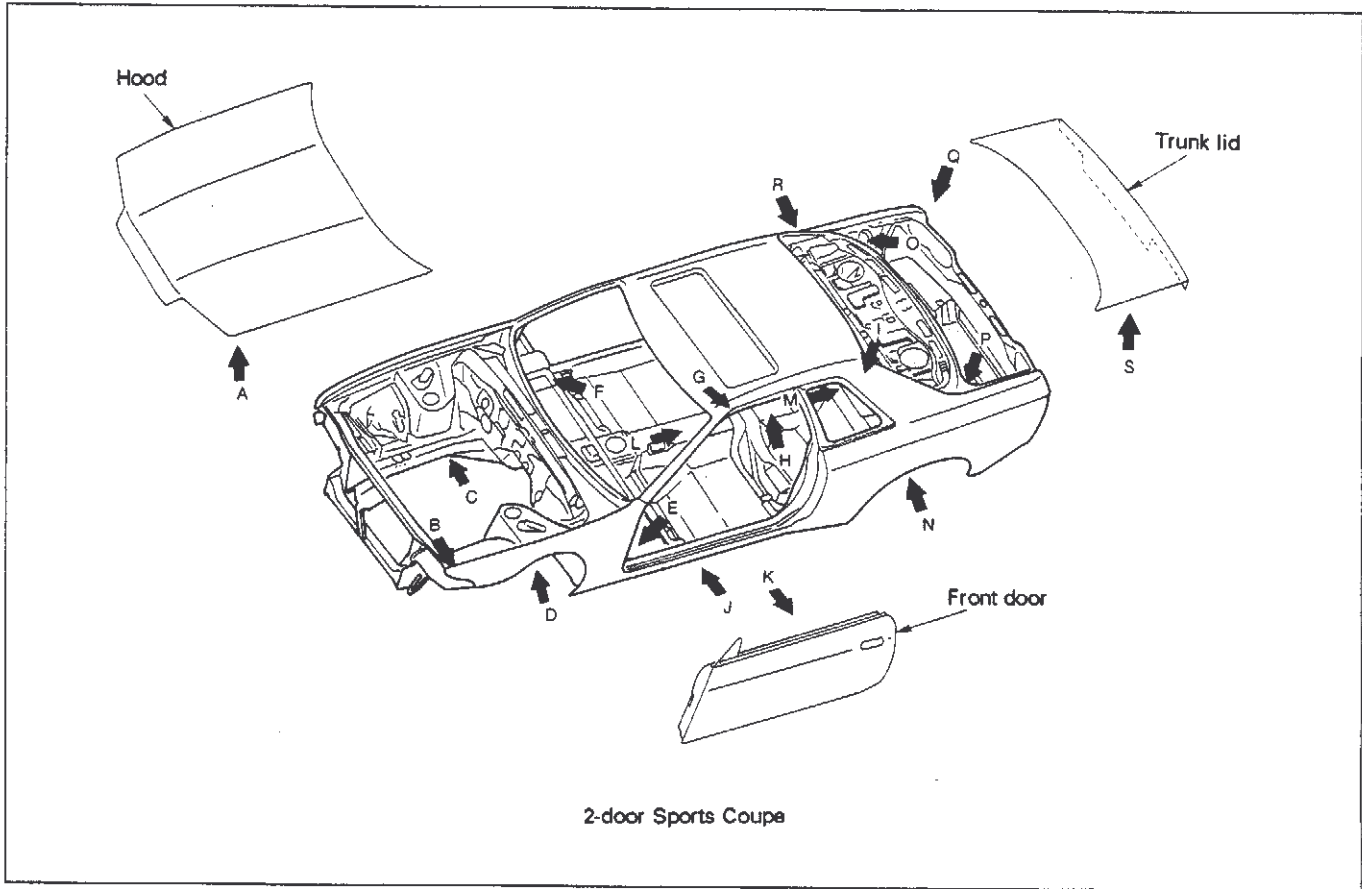

D1 BODY

2. Sealing (Cont'd)

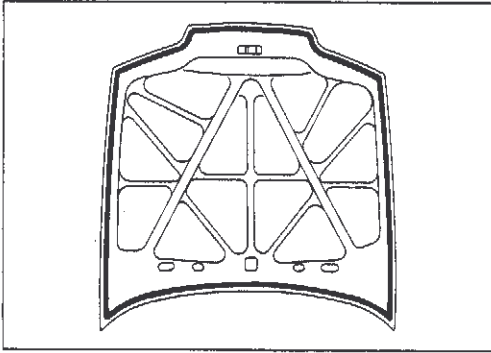

View A

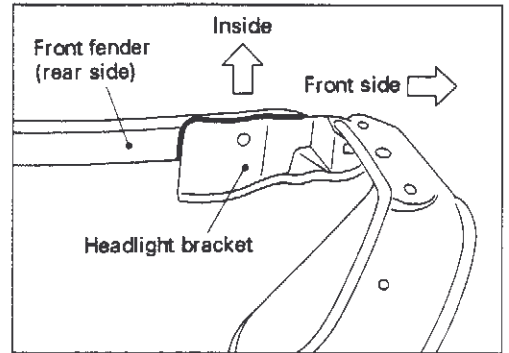

View B

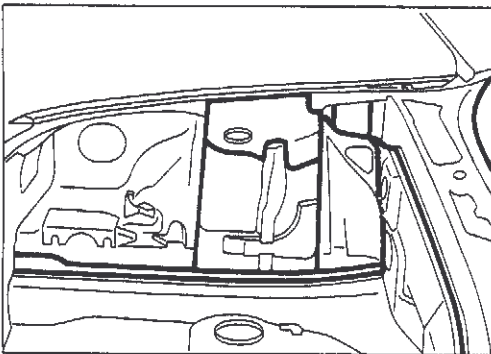

View C

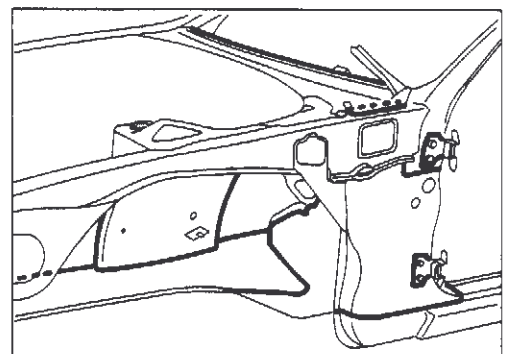

View D

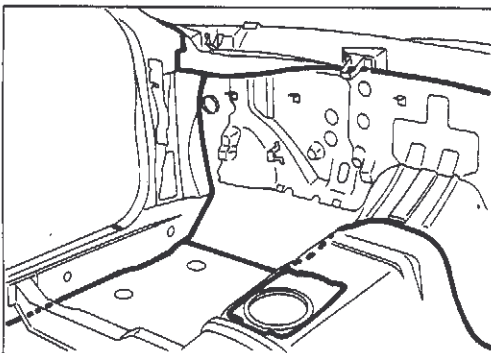

View E

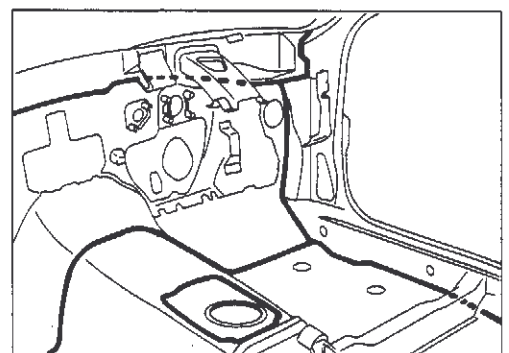

View F

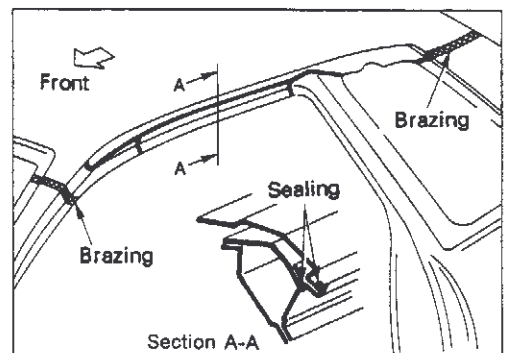

View G (2-door)

D1 BODY

2. Sealing (Cont'd)

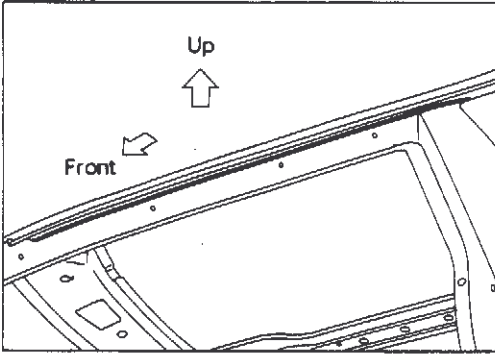

View H (2-door)

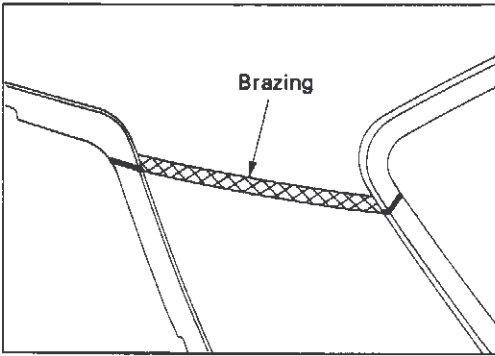

View I (2-door)

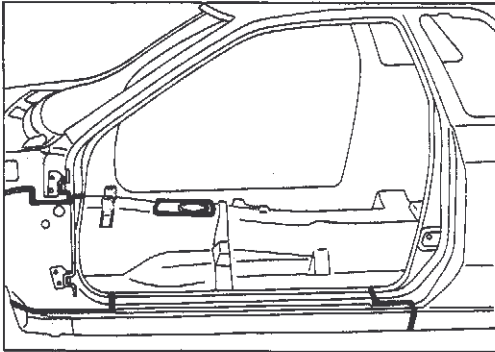

View J (2-door)

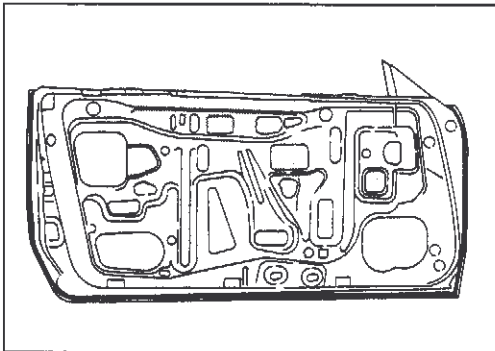

View K (2-door)

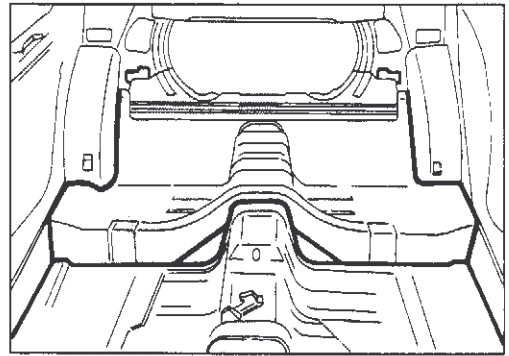

View L

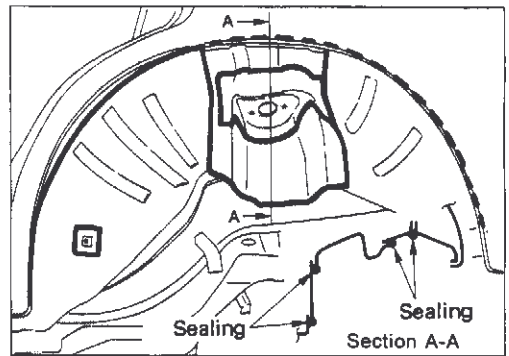

View N

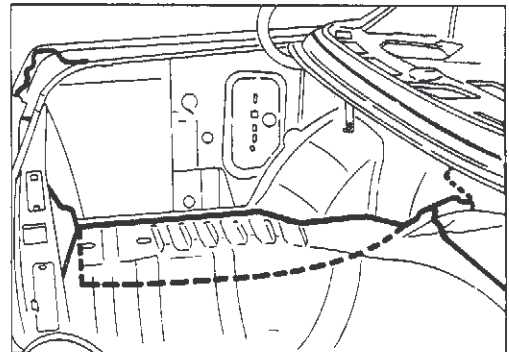

View P

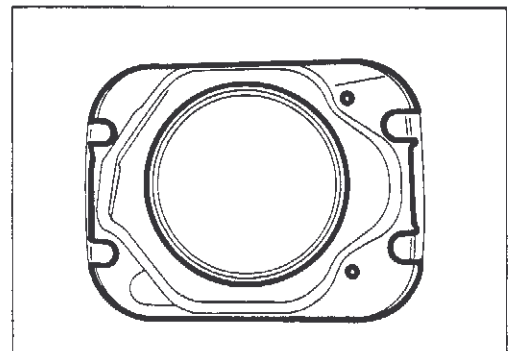

View R

D1 BODY

2. Sealing (Cont'd)

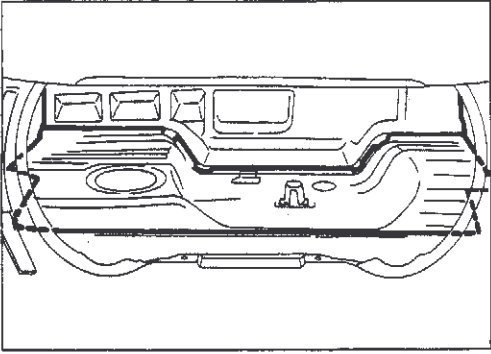

View M

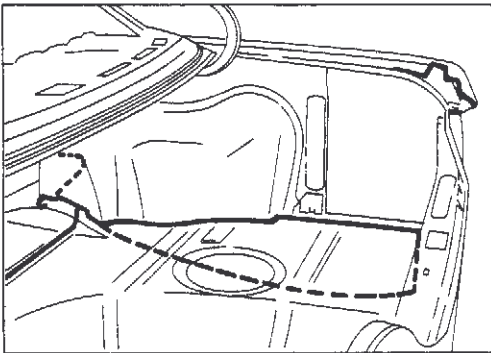

View O

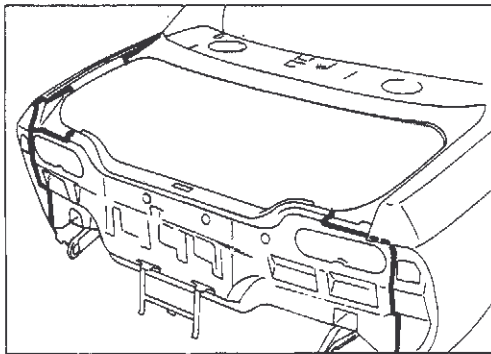

View Q

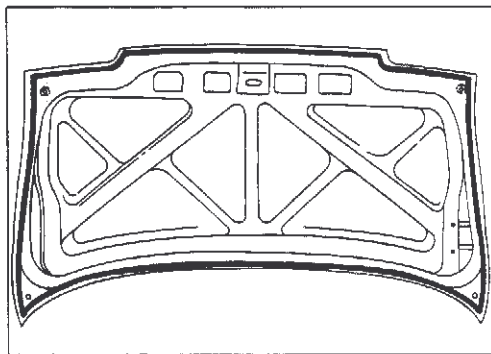

View S

D2 BODY EXTERIOR

1. Bumper

1-1 BUMPER FASCIA REMOVAL AND INSTALLATION

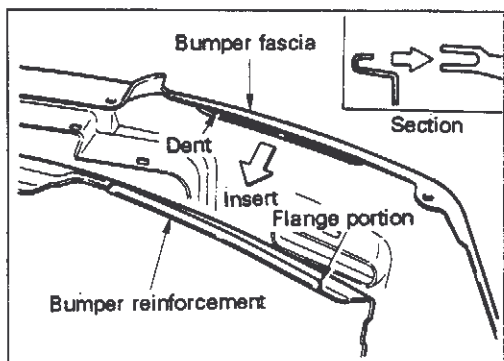
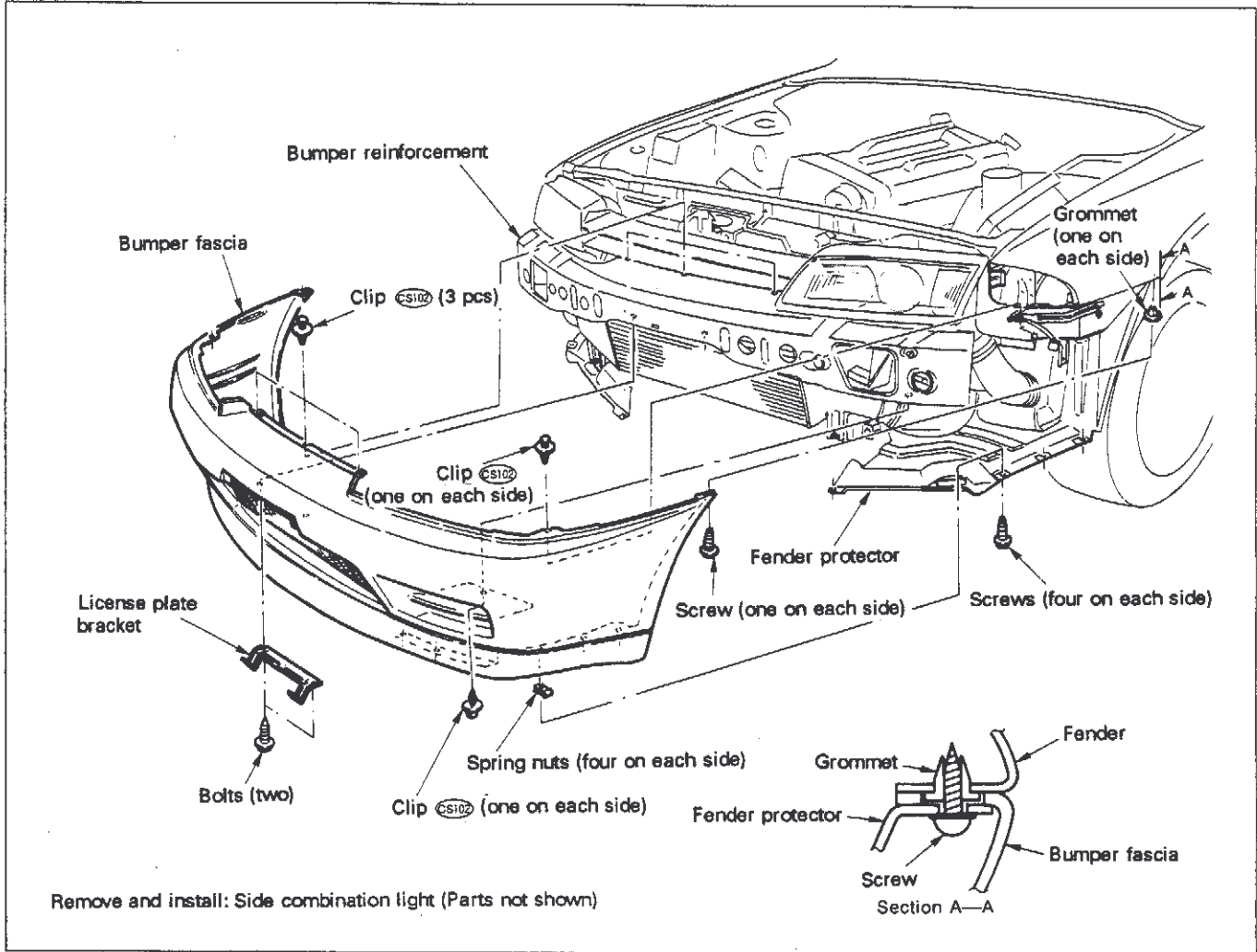

[Point 1] Bumper fascia removal

- First remove bumper fascia separately because intercooler tube prevents removal of bumper assembly.

[Point 2] Bumper fascia installation

- Install bumper fascia by fitting flange portion of bumper reinforcement into dent of bumper fascia.

D2 BODY EXTERIOR

1. Bumper (Cont'd)

1-2 BUMPER REINFORCEMENT

(1) Removal and installation

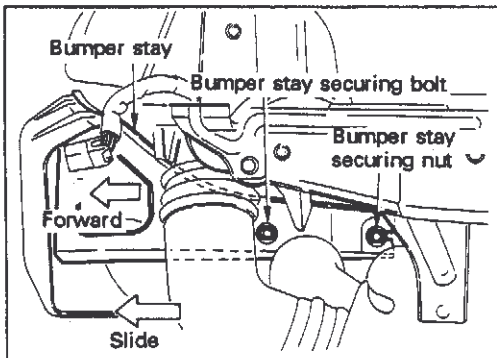
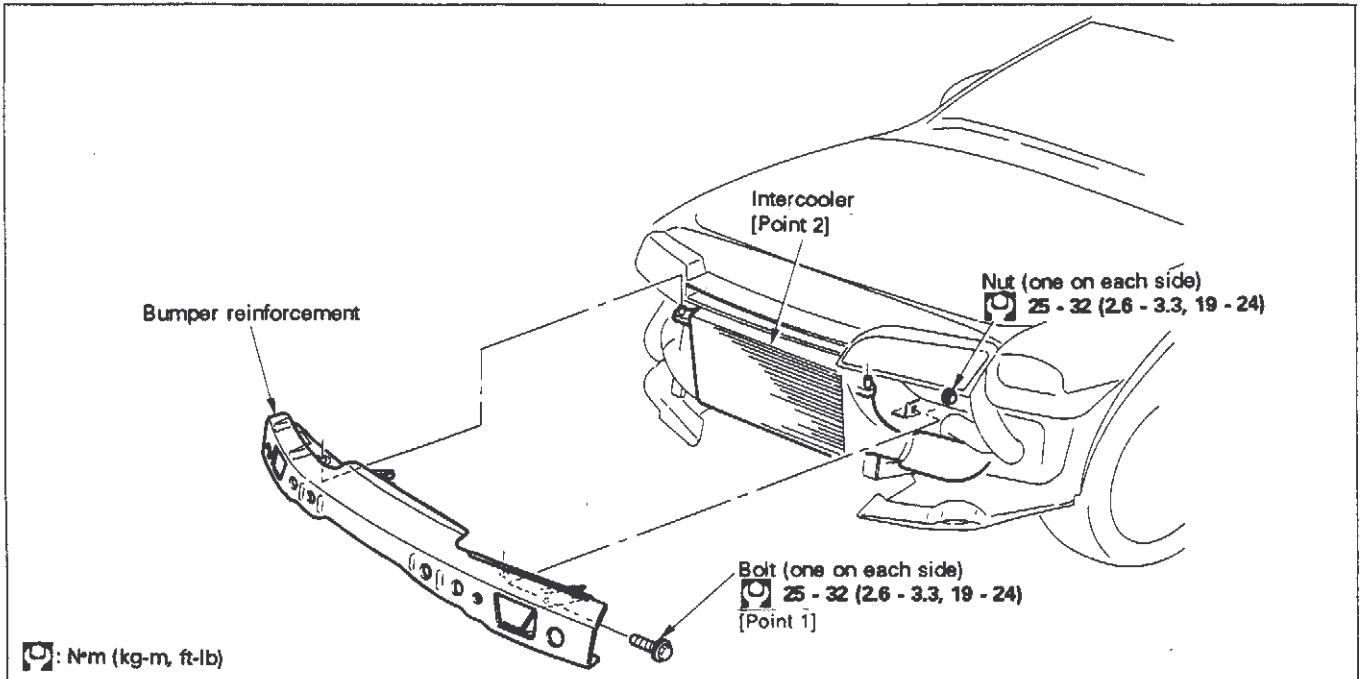

[Point 1] Bumper stay removal

- Remove bumper stay securing bolt.
- Loosen bumper stay securing nut, and remove bumper stay from body by sliding forward.

NOTE:

Do not remove bumper stay securing nut. It should only be loosened but kept attached to stud bolt on body side.

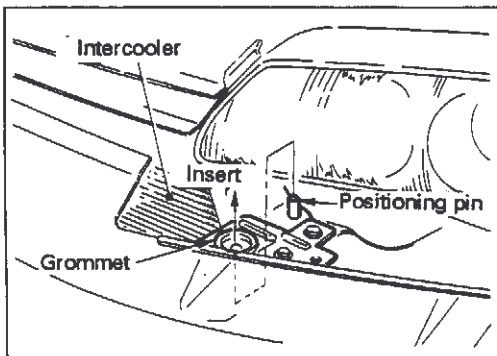

[Point 2] Bumper stay installation

- Attach grommet to bumper stay bracket as shown at left, and then fit grommet onto positioning pin located on the upper part of intercooler.

D2 BODY EXTERIOR

1. Bumper (Cont'd)

(2) Bumper reinforcement disassembly

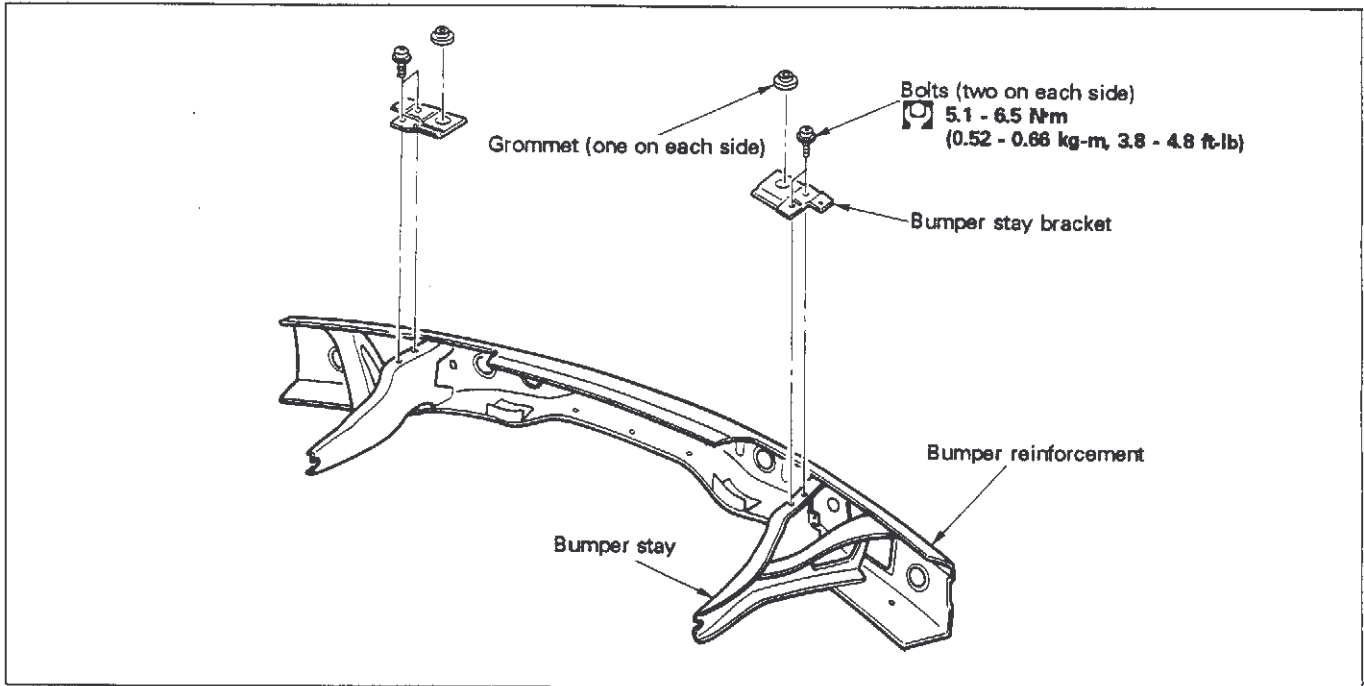

1-3 REAR BUMPER

(1) Removal and installation

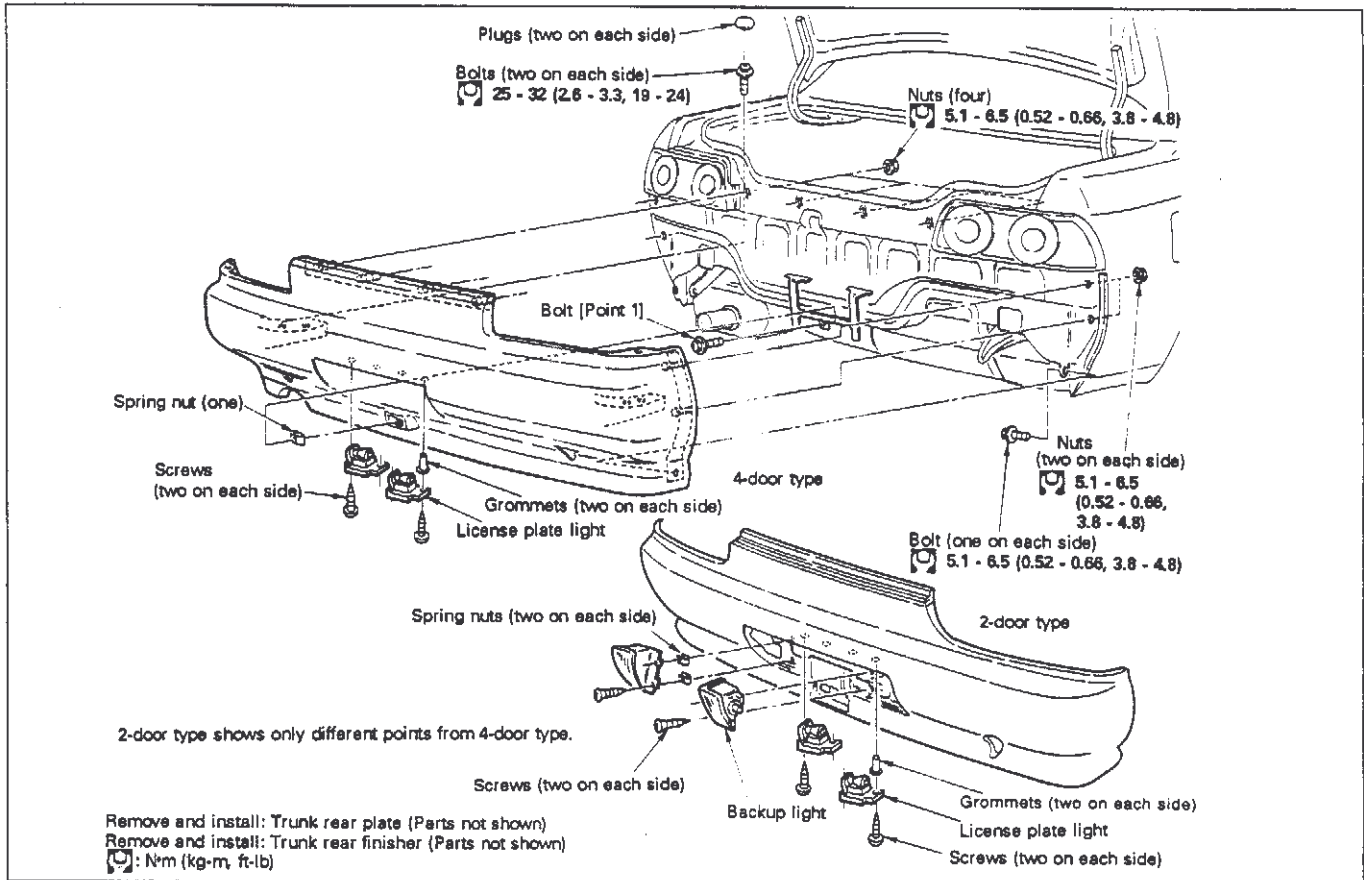

D2 BODY EXTERIOR

1. Bumper (Cont'd)

[Point 1] License plate bracket removal

- Remove bolt from rear side of license plate.
- Pull up bracket together with license plate.

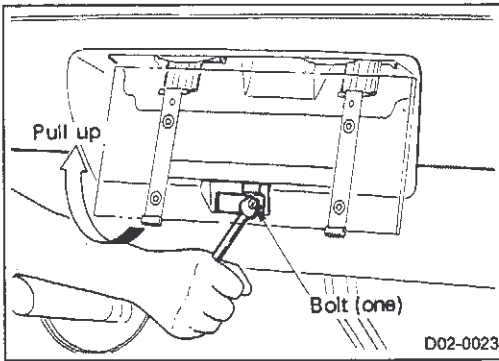

[Point 2] License plate bracket installation

- With 2-door type vehicle, install license plate bracket as shown after replacing bumper, because space is limited around license plate bracket securing bolt.

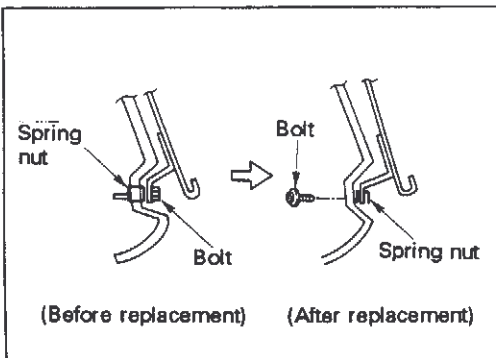

D2 BODY EXTERIOR

1. Bumper (Cont'd)

(2) Disassembly

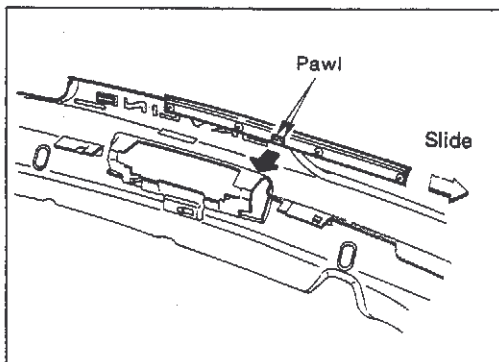
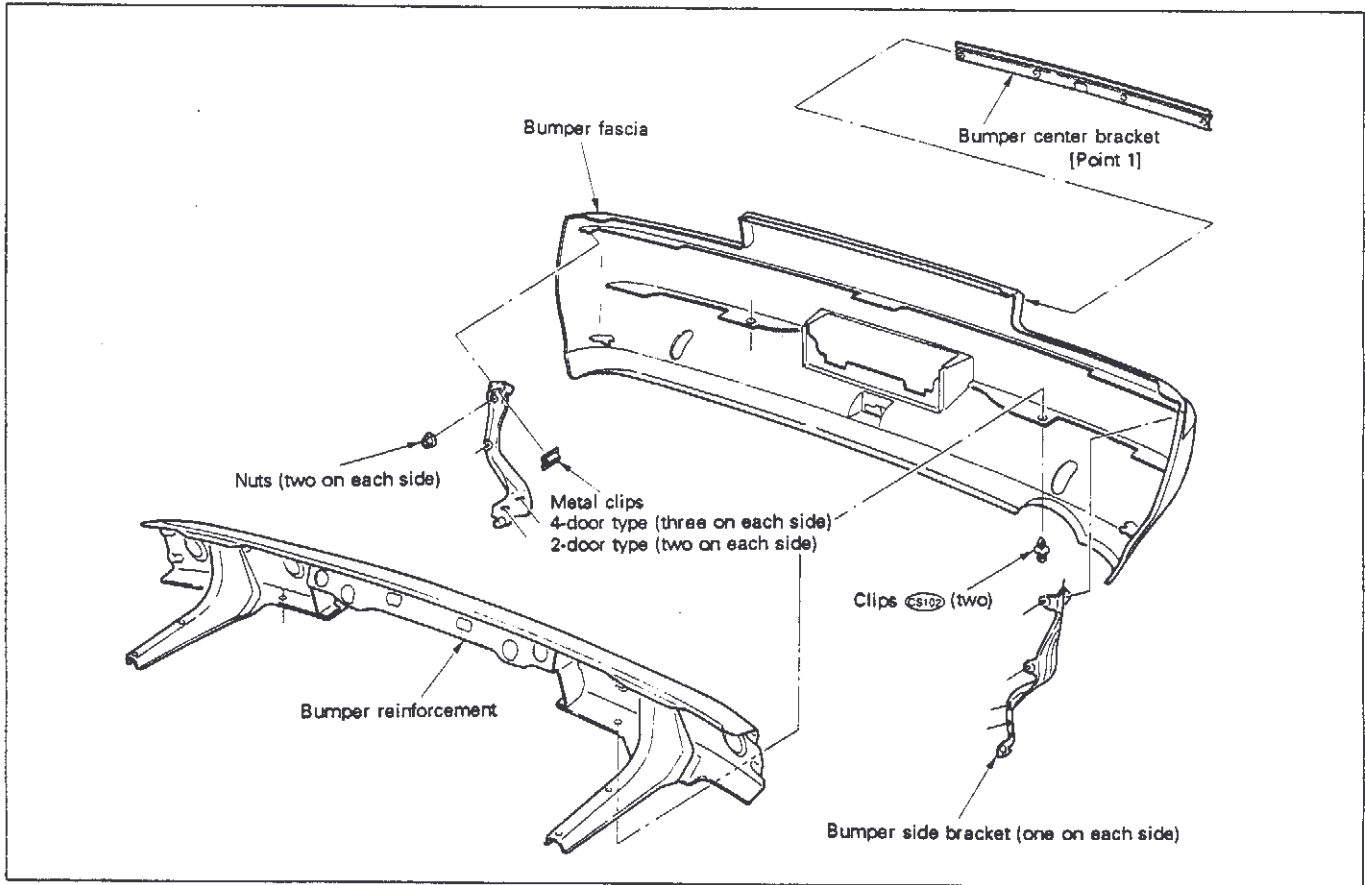

[Point 1] Bumper center bracket removal

- Pull out two pawls located at the center of bumper center bracket in the direction of arrow (➡) using standard screwdriver.
- Draw out bumper center bracket from bumper fascia by sliding it either rightward or leftward.

D2 BODY EXTERIOR

2. Grille

2-1 FRONT GRILLE REMOVAL AND INSTALLATION

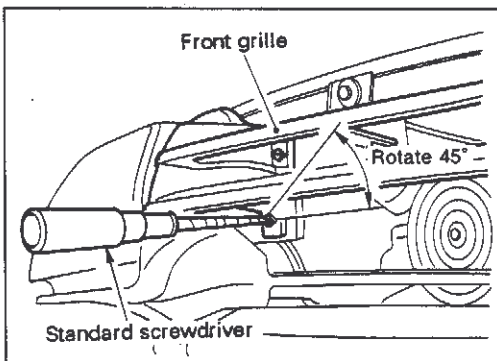
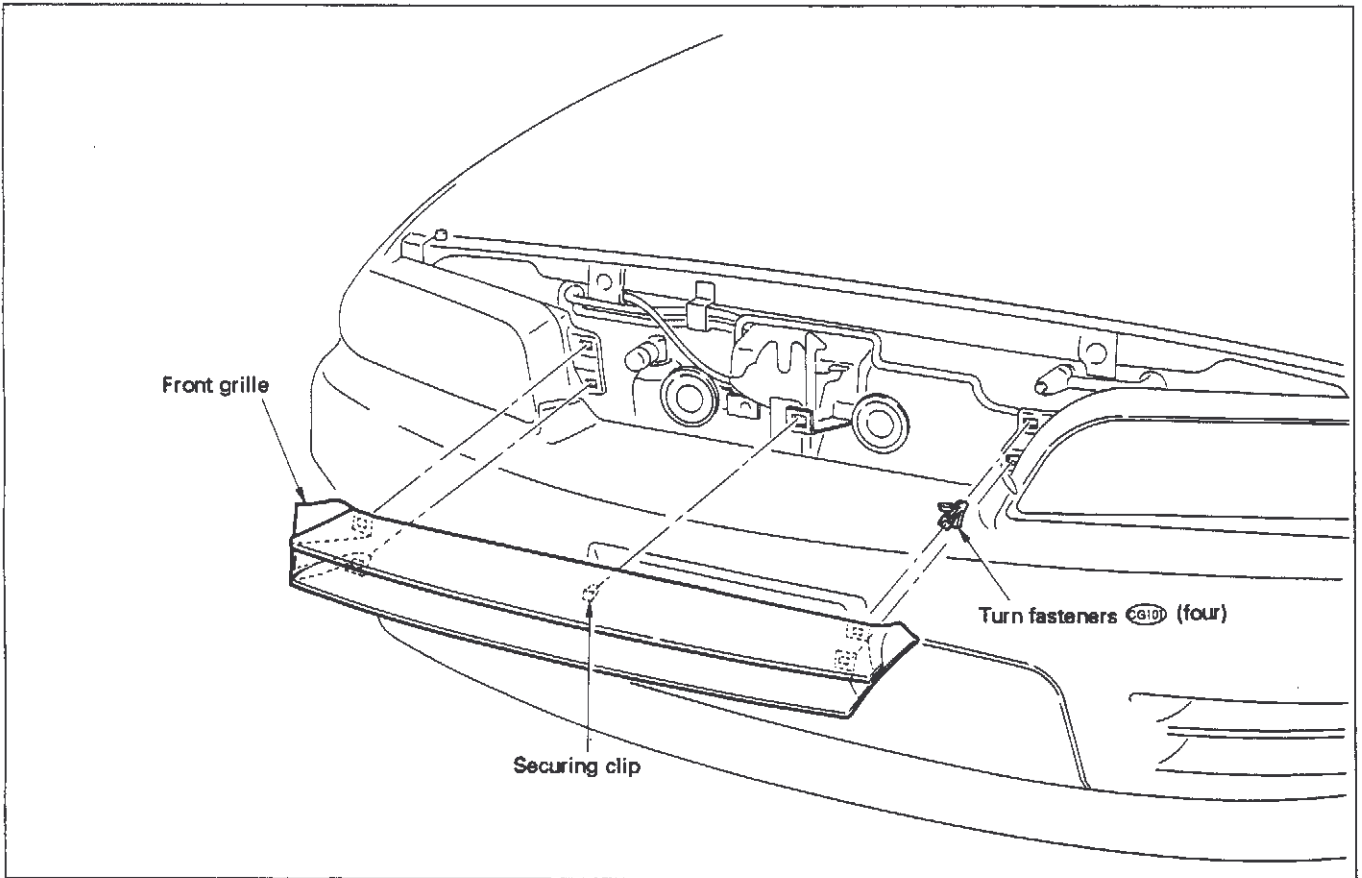

[Point 1] Turn fastener removal

- Rotate front grille upper side turn fastener 45° by fitting screwdriver tip into slot of turn fastener head, and remove turn fastener.
Wrap vinyl tape or cloth around metal part of screwdriver to prevent grille and bumper from being scratched.

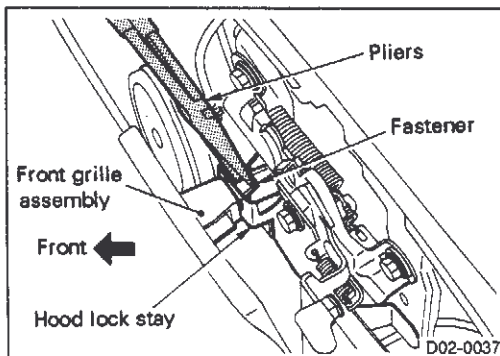

[Point 2] Securing clip removal

- Remove clip by holding with pliers from rear side of hood lock stay.

D2 BODY EXTERIOR

4. Molding

4-1 WINDSHIELD MOLDING

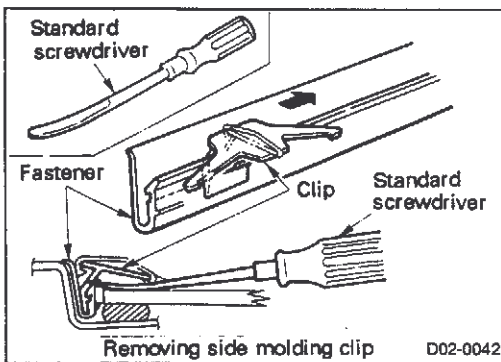
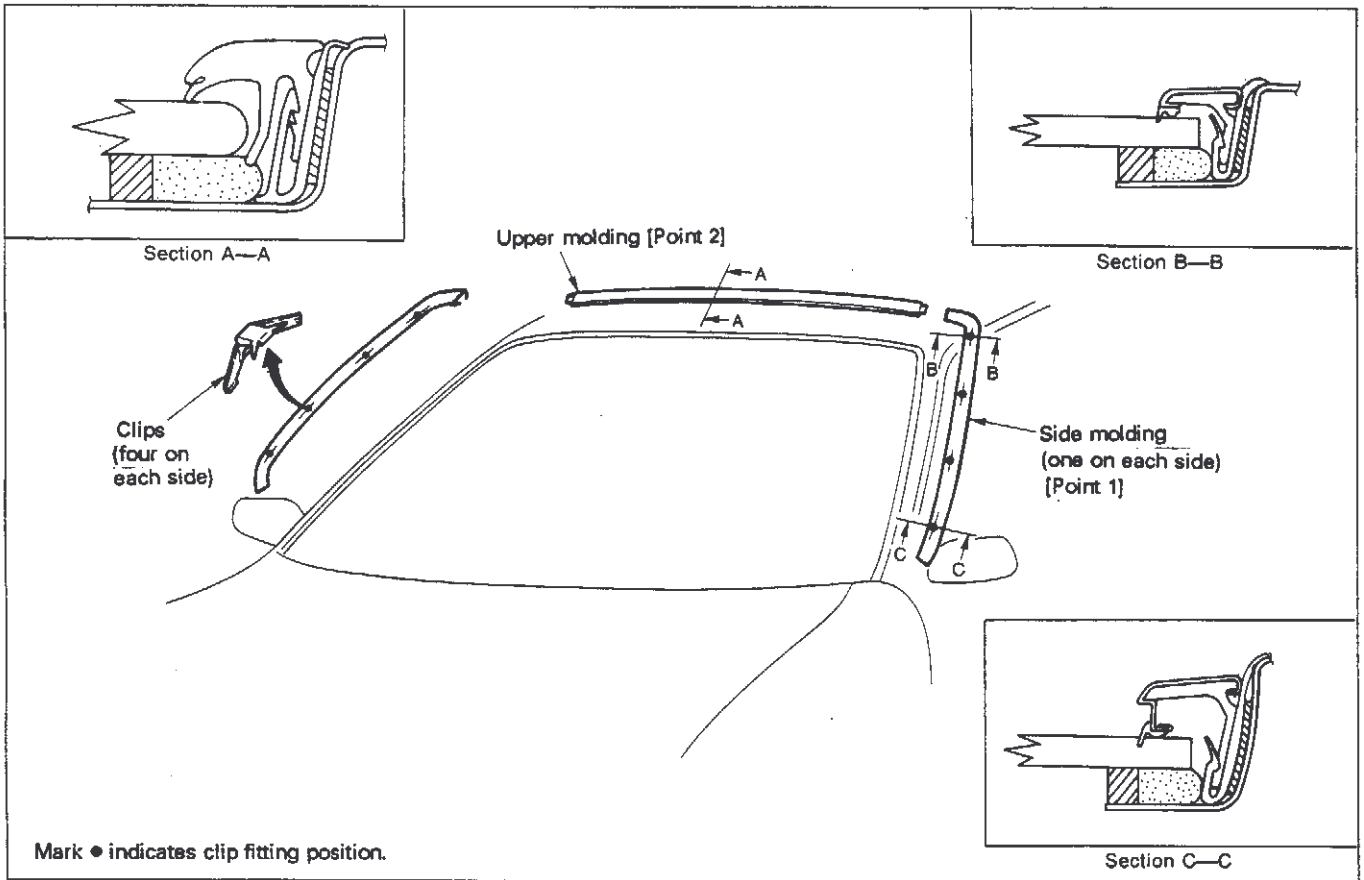

[Point 1] Side molding removal and installation

Removal

- ① Using standard screwdriver with its end portion bent as shown, disengage fastener from side molding by sliding lower two side molding clips.

NOTE:

Be sure to apply cushioning cloth under screwdriver to prevent glass from being damaged.

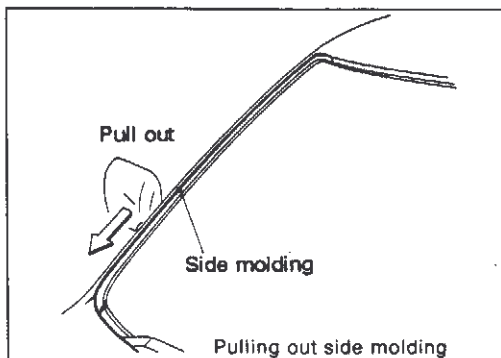

- ② Remove side molding from fastener by pulling out lower end of molding.

D2 BODY EXTERIOR

4. Molding (Cont'd)

Installation

- ① Fit clip into side molding as shown at left.

NOTE:

Four different clips are used; Pay attention not to confuse clips.

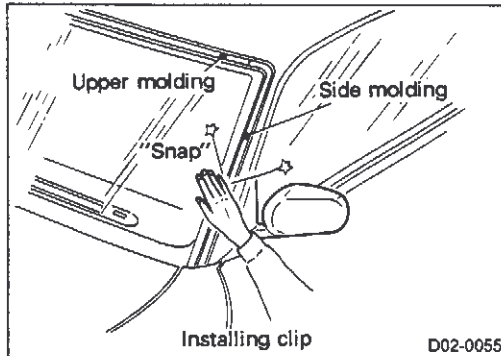
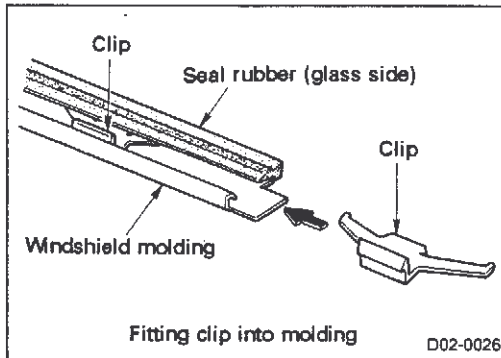

- ② Fit upper end of side molding into upper molding, and tap side molding clip portion with hand until clip fits in fastener with a snap.

NOTE:

Do not apply undue force when tapping. If difficult to fit, change clip position slightly.

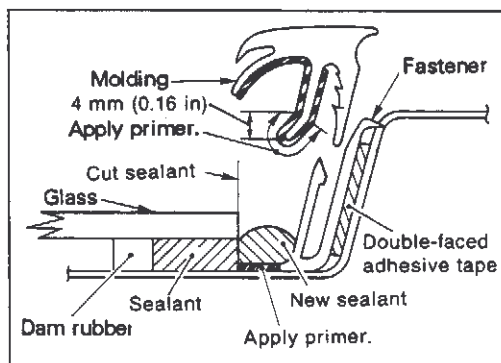

[Point 2] Upper molding removal and installation

- ① After removing side molding, pull out upper molding by lifting its end up.
- ② Cut sealant at end of glass, and clean panel surface after removing fastener.
- ③ Bond fastener to body using double-faced adhesive tape, then apply primer to panel and molding leg portions.
- ④ Pack sealant between glass and body so that molding leg can be bonded securely.
- ⑤ Squeeze upper molding into position.

NOTE:

Repair panel surface if scratched when cutting sealant.

D2 BODY EXTERIOR

4. Molding (Cont'd)

4-2 REAR WINDOW MOLDING

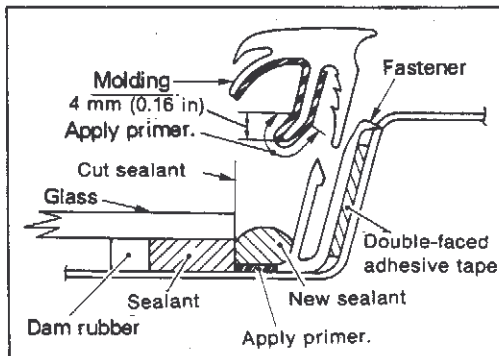
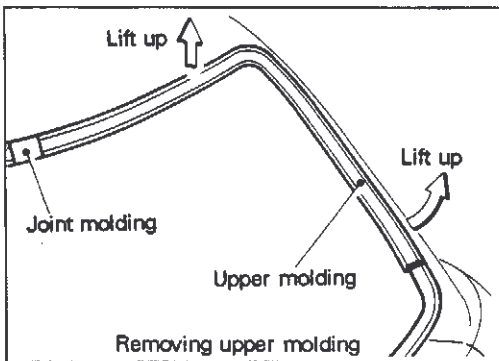
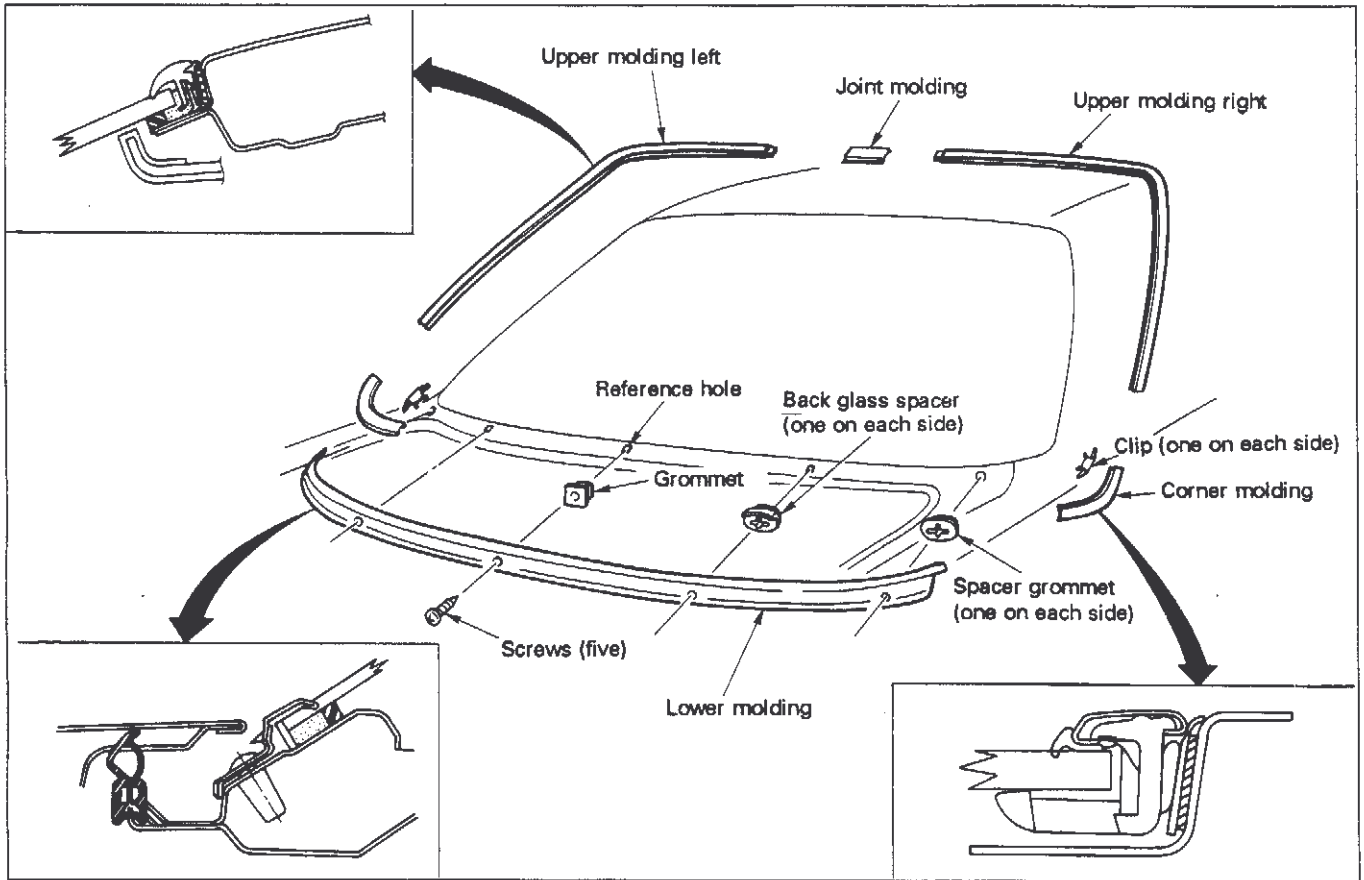

[Point 1] Upper molding removal and installation

- ① Remove lower molding securing screws, and remove molding from body.
- ② Remove corner molding clips, and remove corner molding from fastener.
- ③ Remove upper molding by lifting its end up.
- ④ Cut sealant at glass end portion, remove faster and clean panel surface.
- ⑤ Bond fastener to body using double-faced adhesive tape, then apply primer to panel and molding leg portion.
- ⑥ Pack sealant between glass and body so that molding leg can be bonded securely.
- ⑦ Bond upper molding and joint molding using sealant to make up sub assembly.
- ⑧ Squeeze upper molding sub assembly into fastener.
- ⑨ Fit clip into corner molding, and fit corner molding to upper molding, then tap molding until it fits snugly into fastener.
- ⑩ Fix lower molding using screws.

NOTE:

Repair panel surface by coating if scratched while cutting sealant.

D2 BODY EXTERIOR

4. Molding (Cont'd)

4-3 DRIP MOLDING REMOVAL AND INSTALLATION

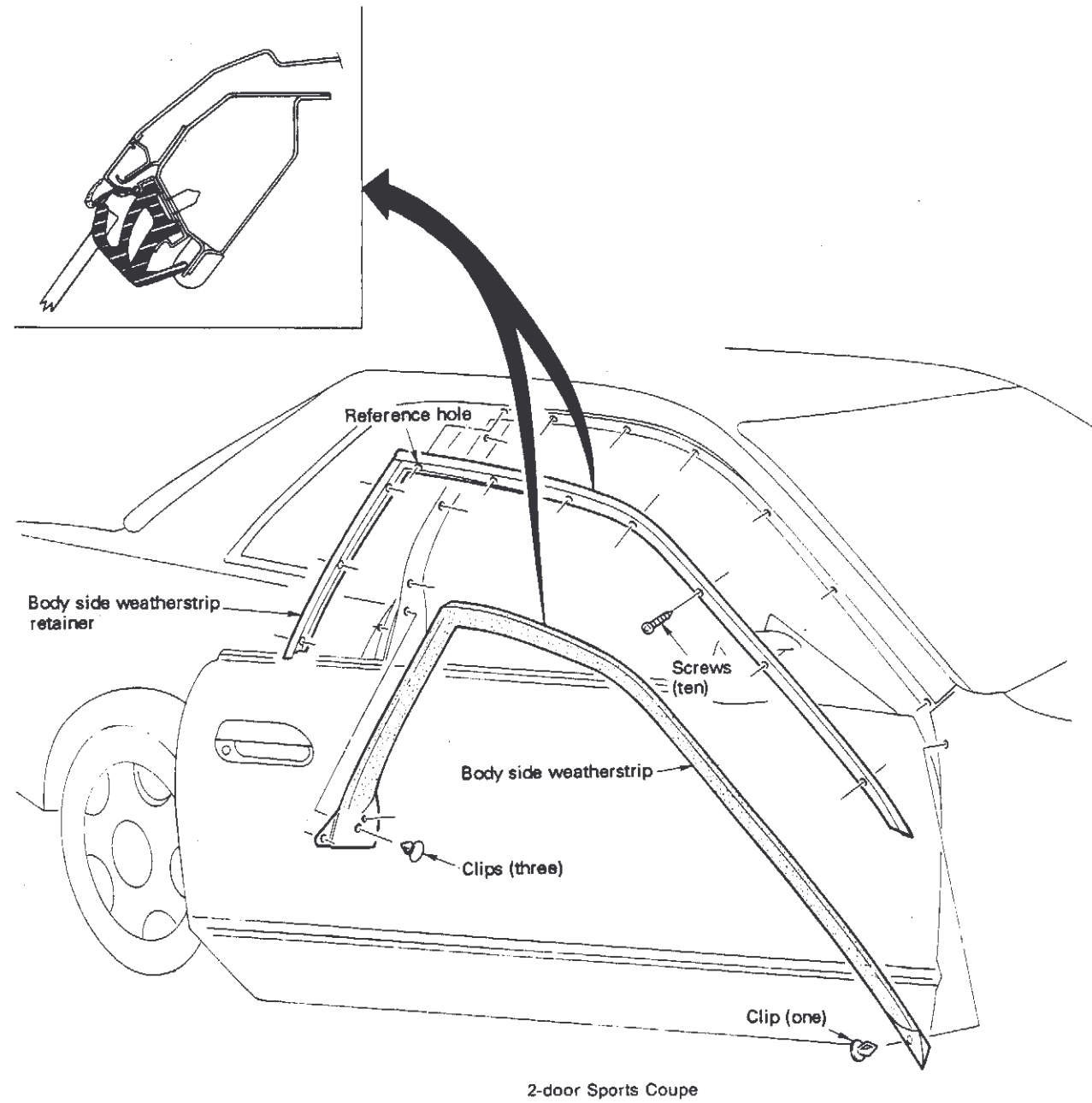

NOTE: Pay attention not to create clearance when installing.

D2 BODY EXTERIOR

4. Molding (Cont'd)

4-4 DOOR OUTSIDE MOLDING REMOVAL AND INSTALLATION

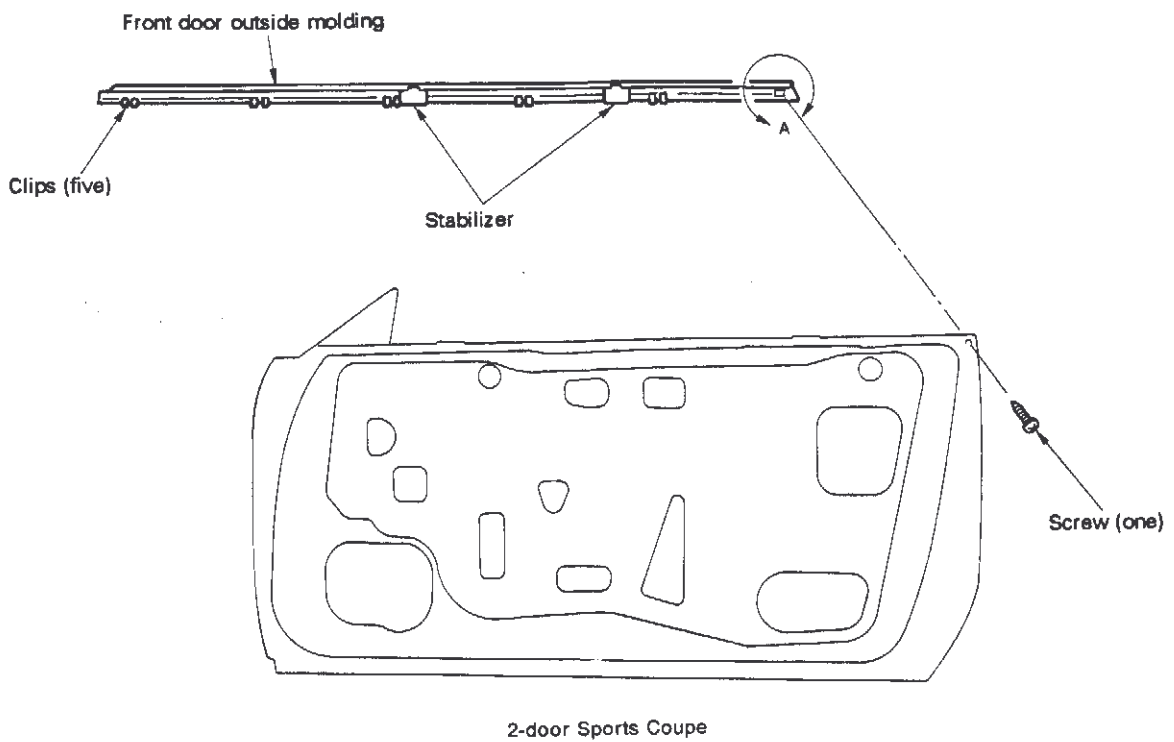
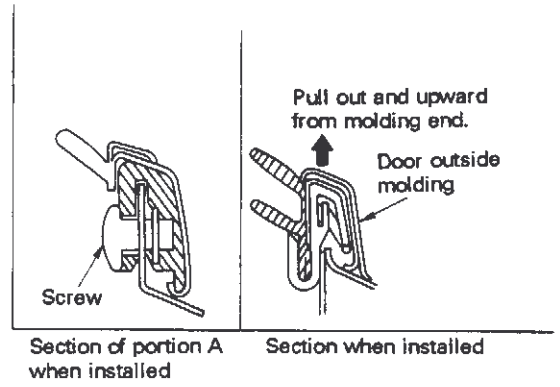

D2 BODY EXTERIOR

5. Window Glass

The windshield, rear window and rear side windows are bonded with urethane sealant. Refer to "Windshield removal and installation" in "Basic Servicing Procedure".

5-1 WINDSHIELD AND REAR WINDOW

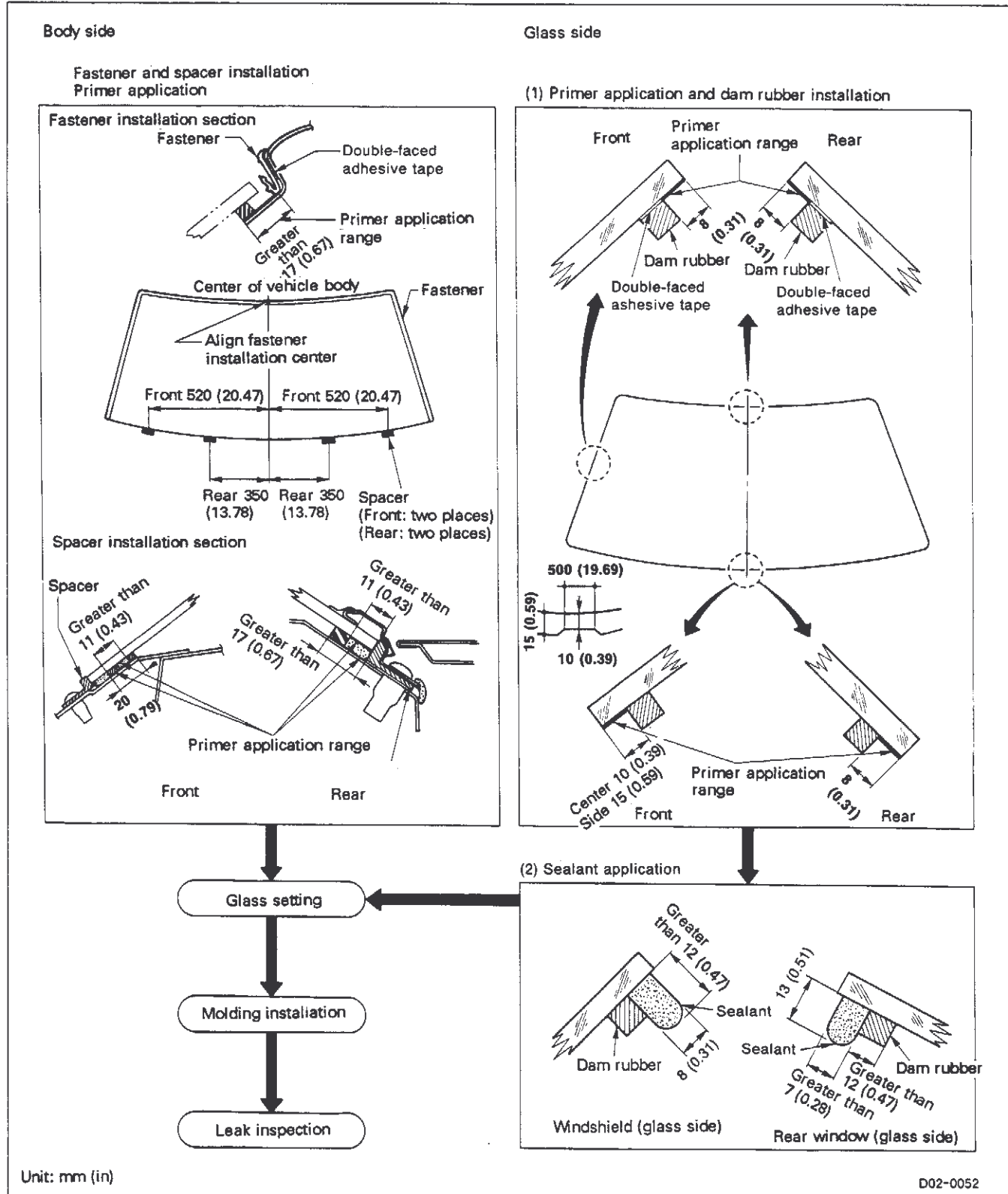

D2 BODY EXTERIOR

5. Window Glass (Cont'd)

5-2 REAR SIDE WINDOW GLASSES (2-door Sports Coupe)

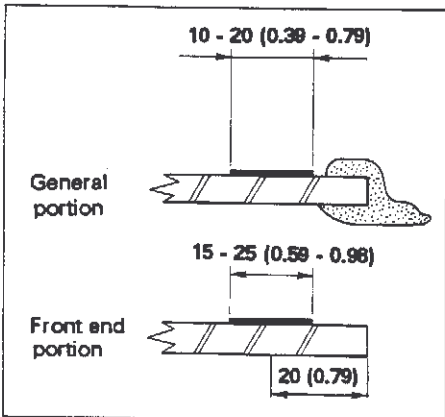
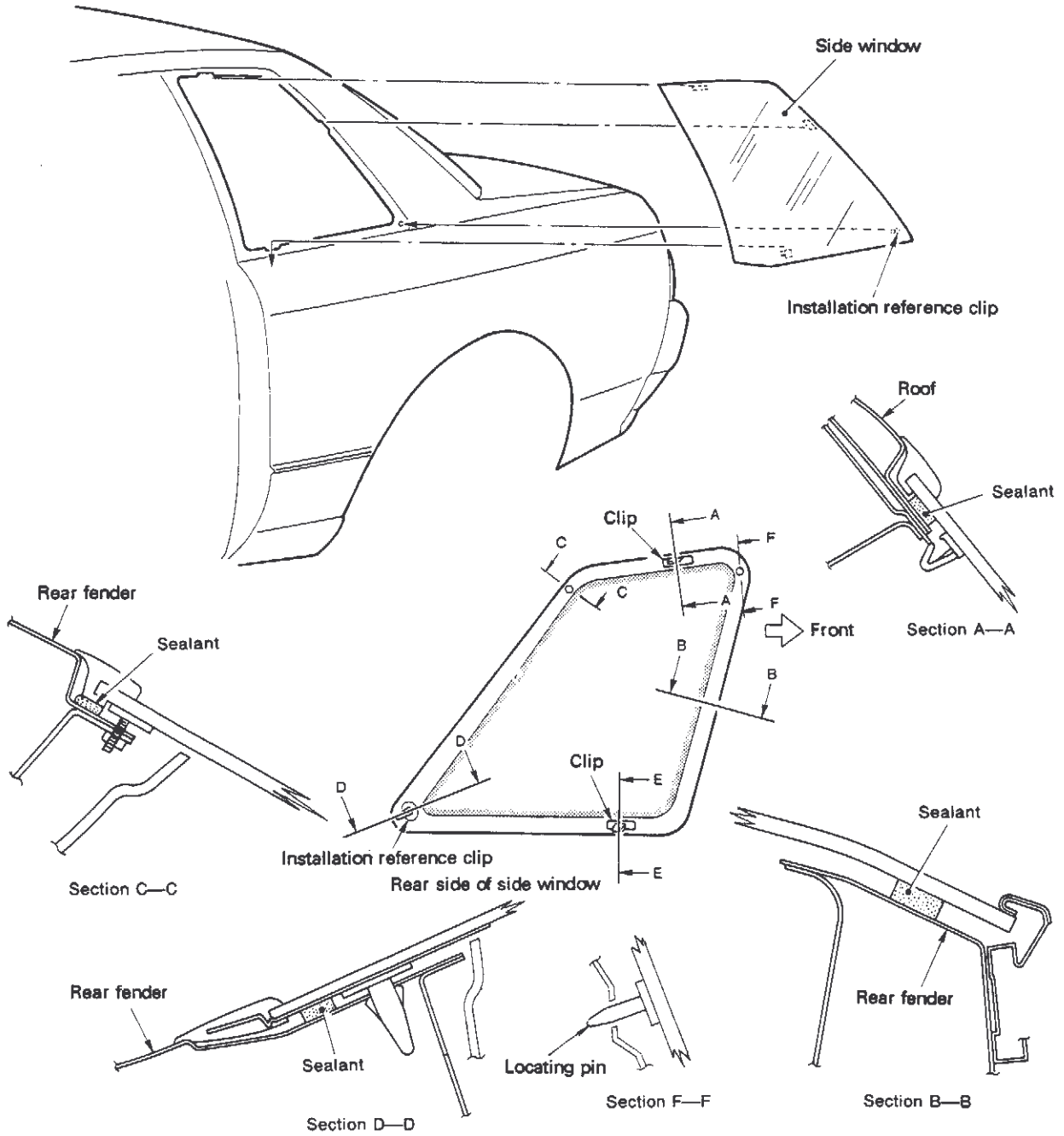

Primer application range (all around)

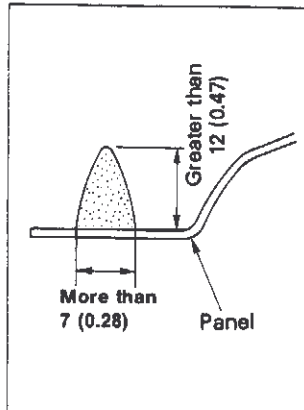

Sealant application quality

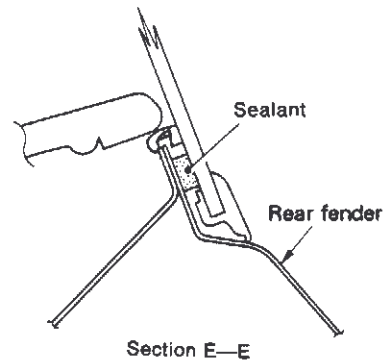

NOTE: Do not apply primer to gradation area.

Unit: mm (in)

D2 BODY EXTERIOR

6. Outside Mirror

6-1 STANDARD AND HEATER FITTED DOOR MIRROR

(1) Components

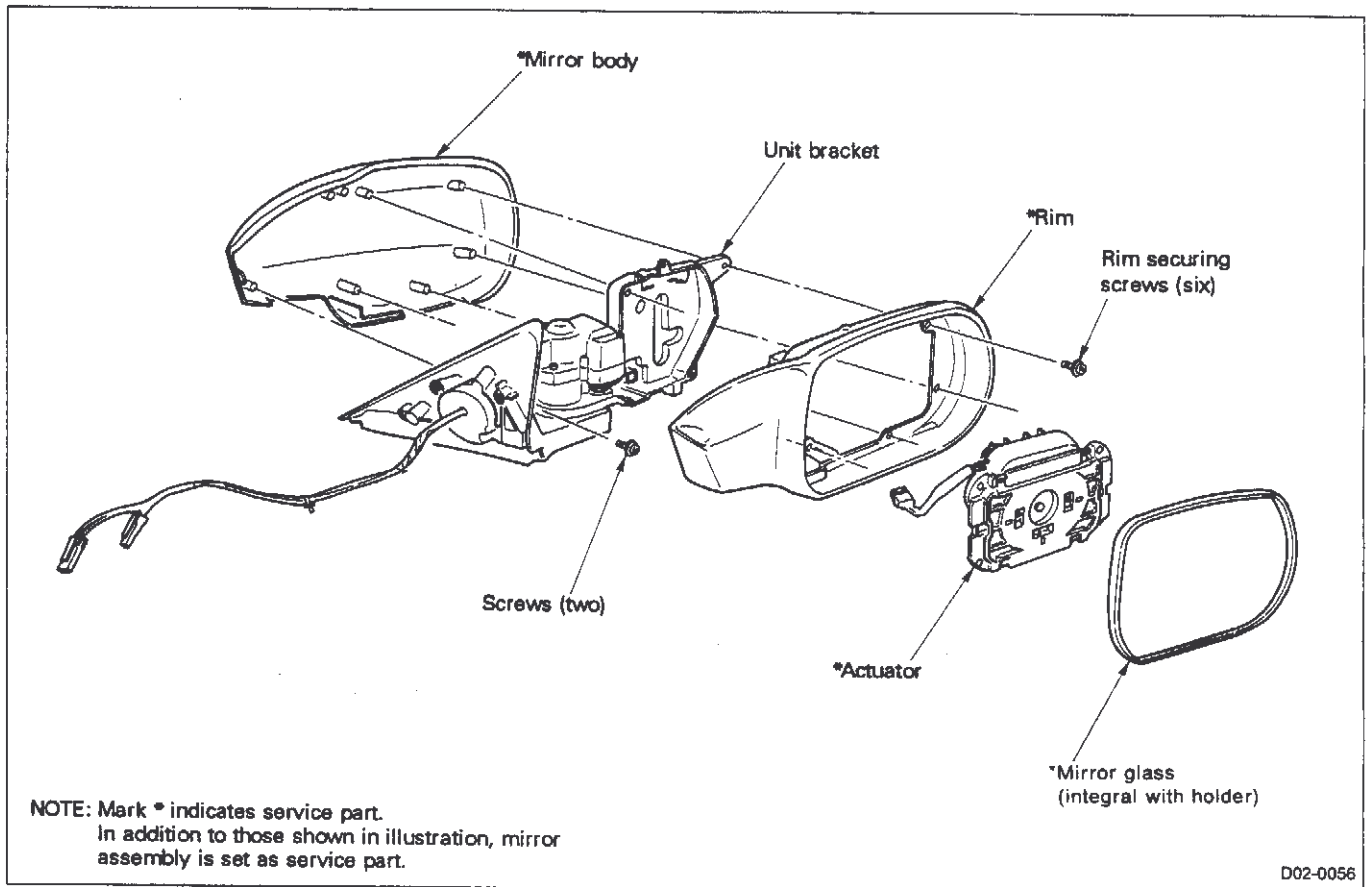

(2) Mirror assembly removal and installation

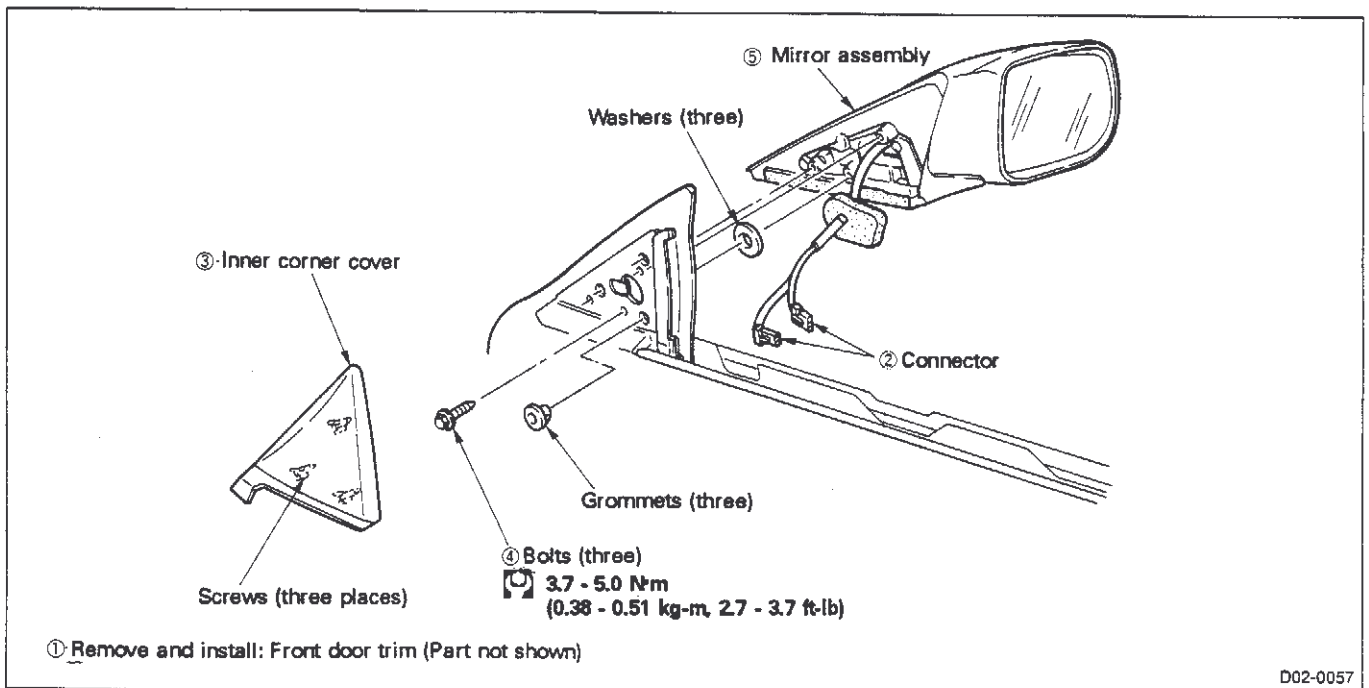

D2 BODY EXTERIOR

6. Outside Mirror (Cont'd)

(3) Mirror removal and installation

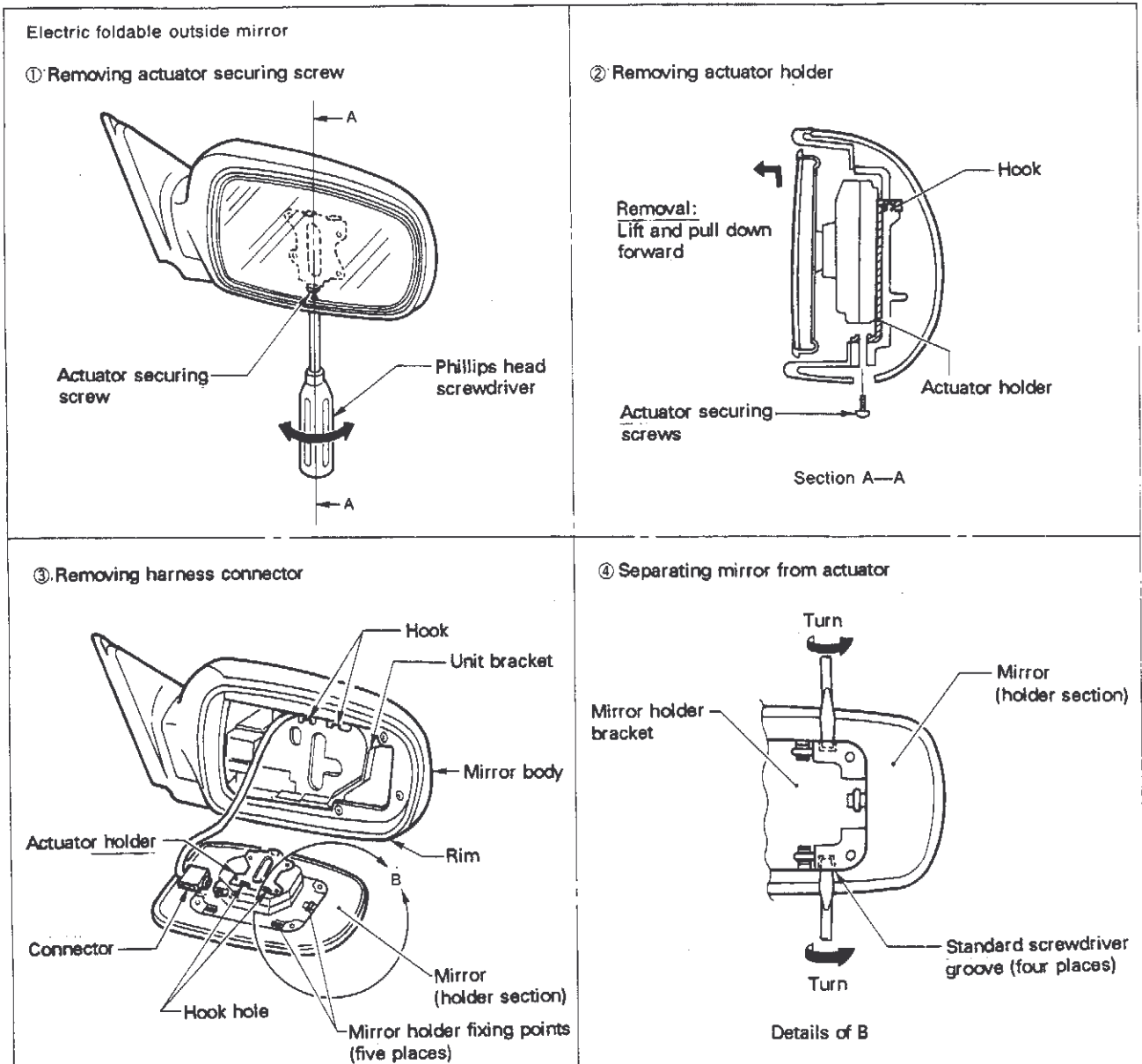

NOTE: To install, proceed as ④ → ③ → ② → ① by reversing the removal sequence.

D2 BODY EXTERIOR

6. Outside Mirror (Cont'd)

(4) Mirror rim removal and installation

Removal

Remove and install: Mirror and actuator [operations (Parts not shown) ①, ② and ③]

- Remove mirror rim securing screws (six) as shown at left.
- Pull out mirror rim from mirror body by detaching rim from mirror body pawl.

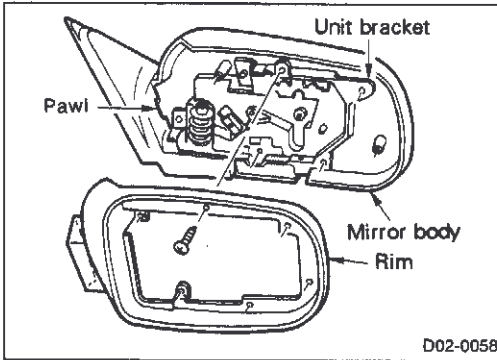

(5) Mirror body removal and installation

Removal

Remove and install: Mirror, actuator [operations ①, ② and ③] and mirror rim

- Remove mirror fixing screws (two) as shown at left.
- Remove mirror body after setting it in storage position.

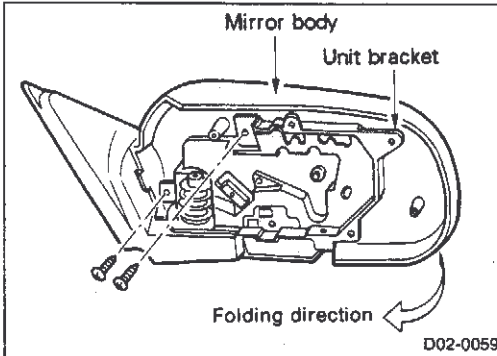

6-2 FENDER MIRROR

(1) Fender mirror removal and installation

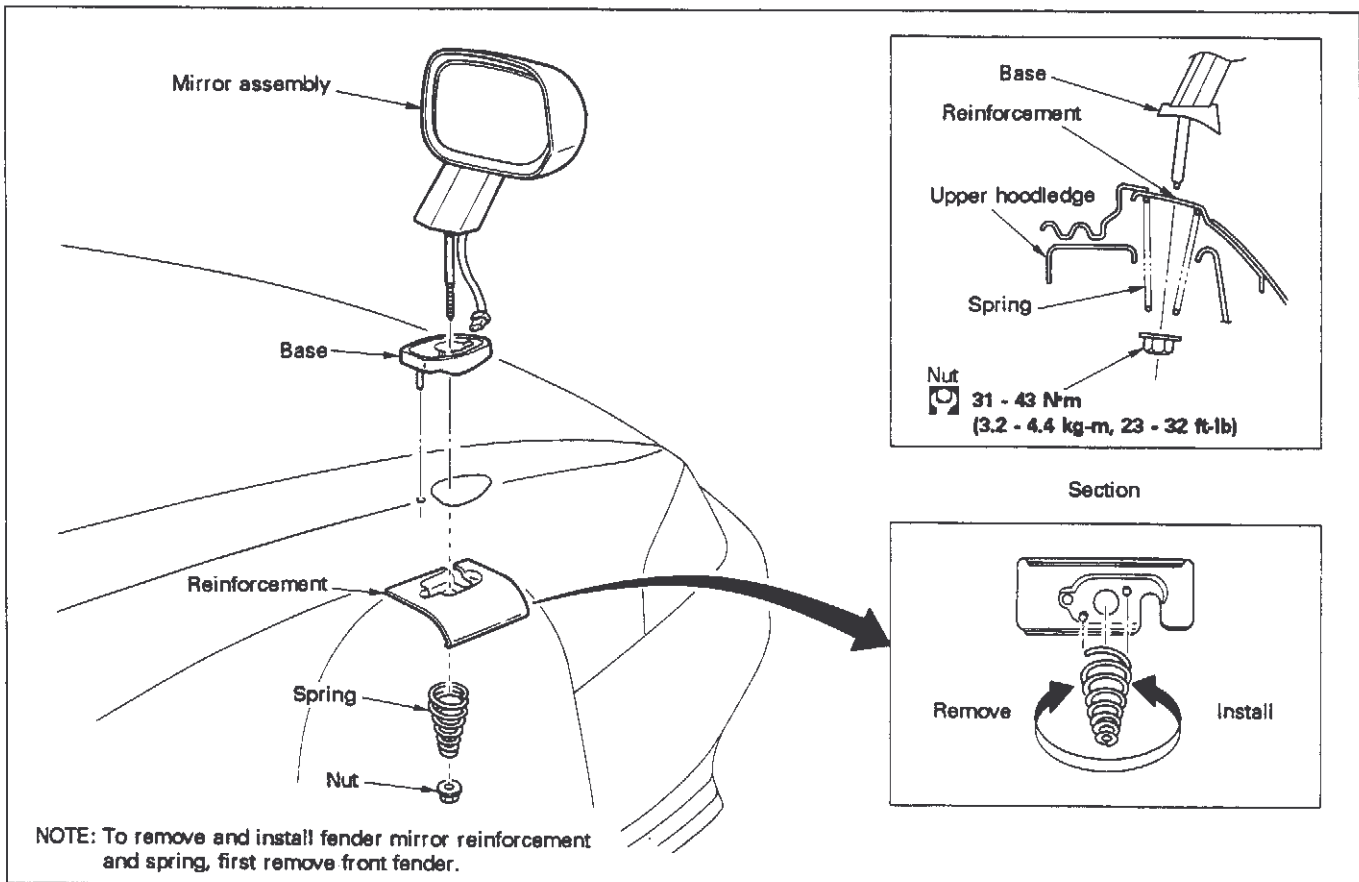

D2 BODY EXTERIOR

6. Outside Mirror (Cont'd)

6-3 CHANGE INTO DOOR MIRROR AND CHANGE INTO FENDER MIRROR

(1) Change from door mirror to fender mirror

① Whether changeable or not and required items

Changeability	Harness connector in fender portion	Front door cover	Electric fender mirror components	Installation position
Yes	Not provided	Provided	Provided	See below

NOTE:

Only patrol car specification has electrically operated mirror.

② Installation position

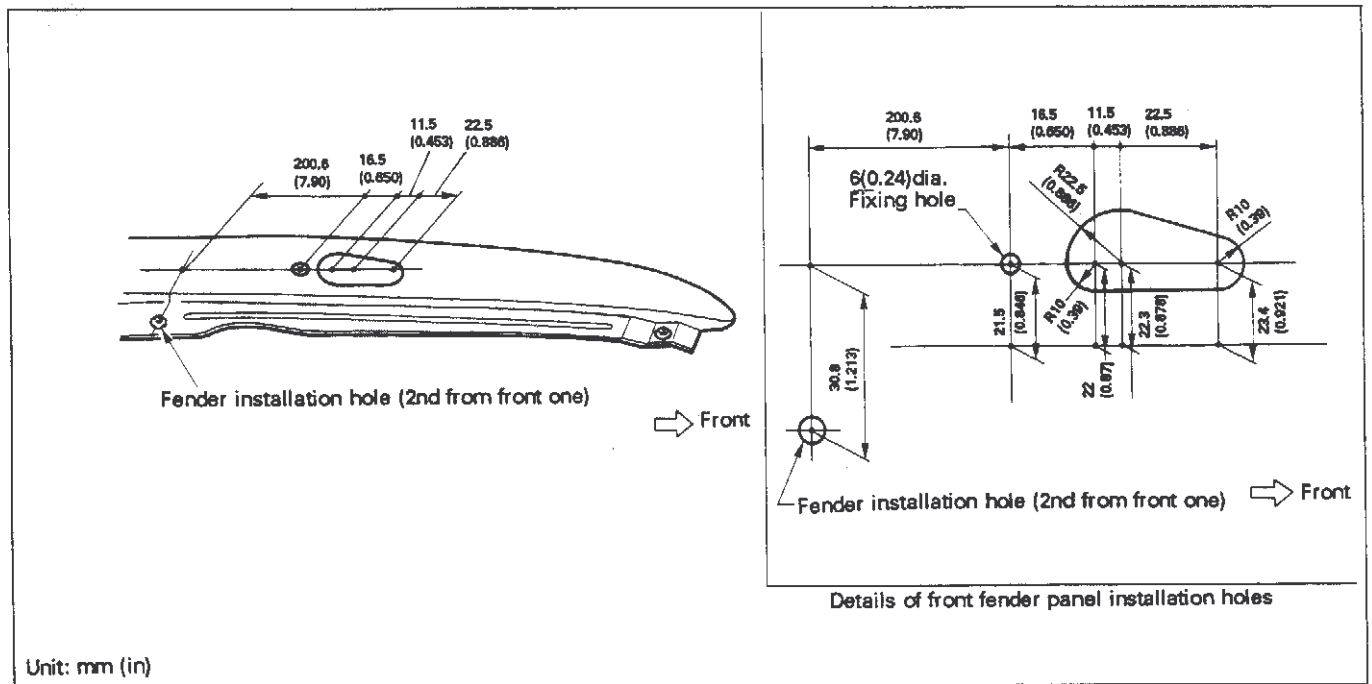

NOTE:

Apply anti-rust coating to drilled holes.

(2) Change from fender mirror to door mirror

① Whether changeable or not and required items

Changeability	Harness up to door	Fender hole stopping patch (service part)	Door mirror
Not provided	Provided	Not provided	Provided

D2 BODY EXTERIOR

7. Spoilers

7-1 FRONT SPOILER REMOVAL AND INSTALLATION

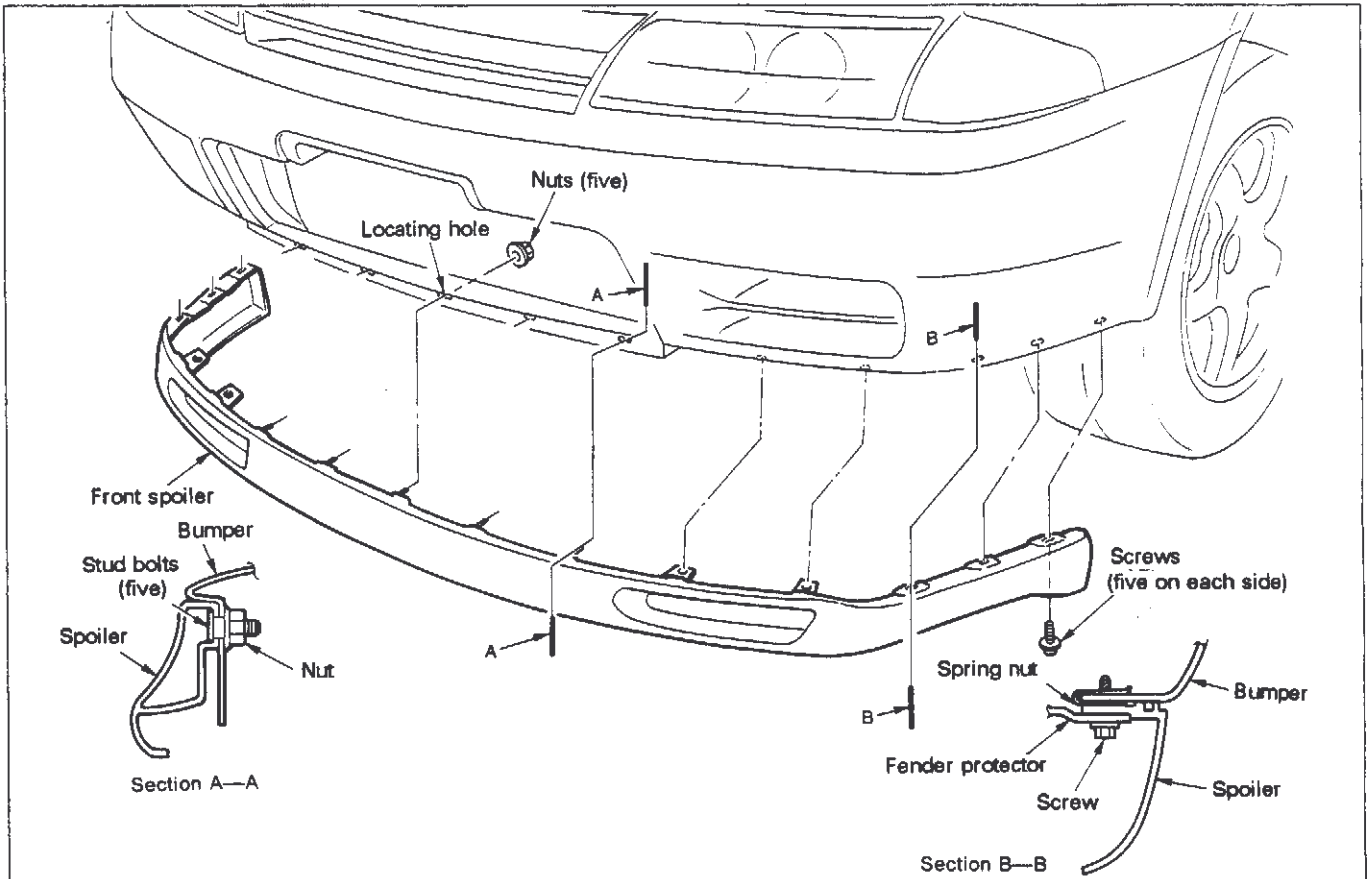

7-2 REAR SPOILER REMOVAL AND INSTALLATION

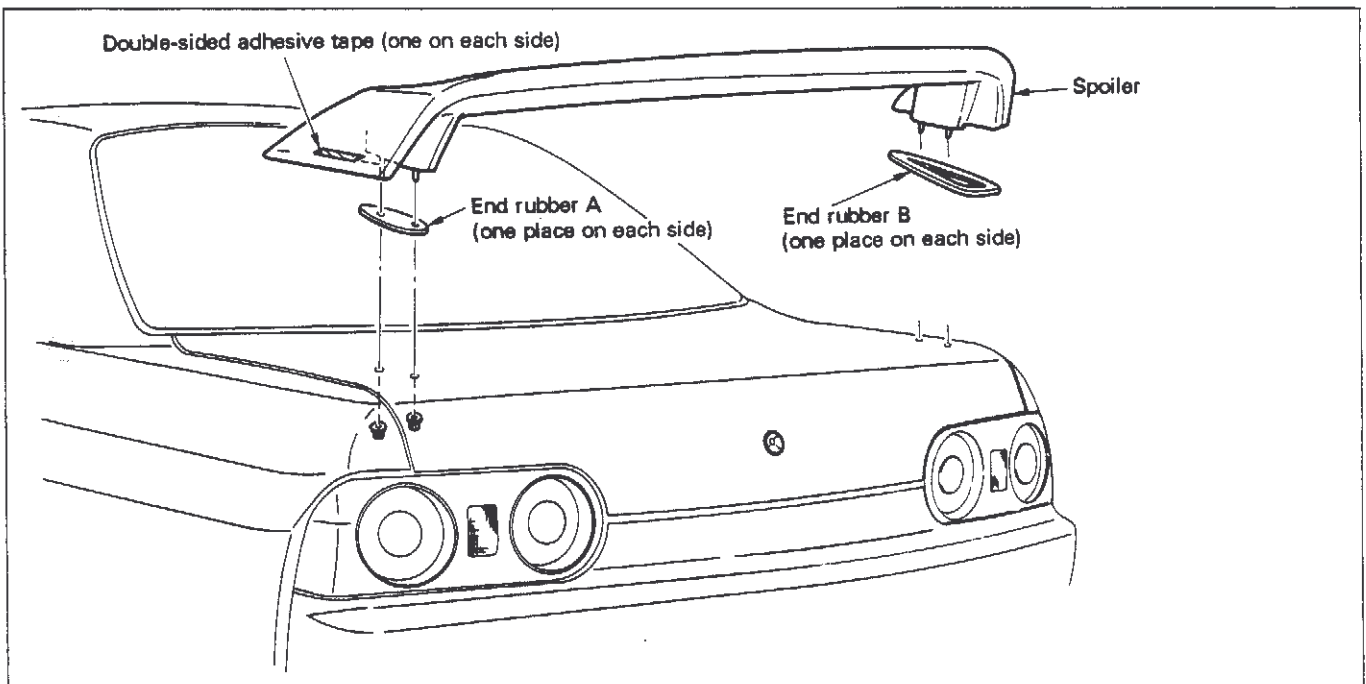

D2 BODY EXTERIOR

8. Drafter

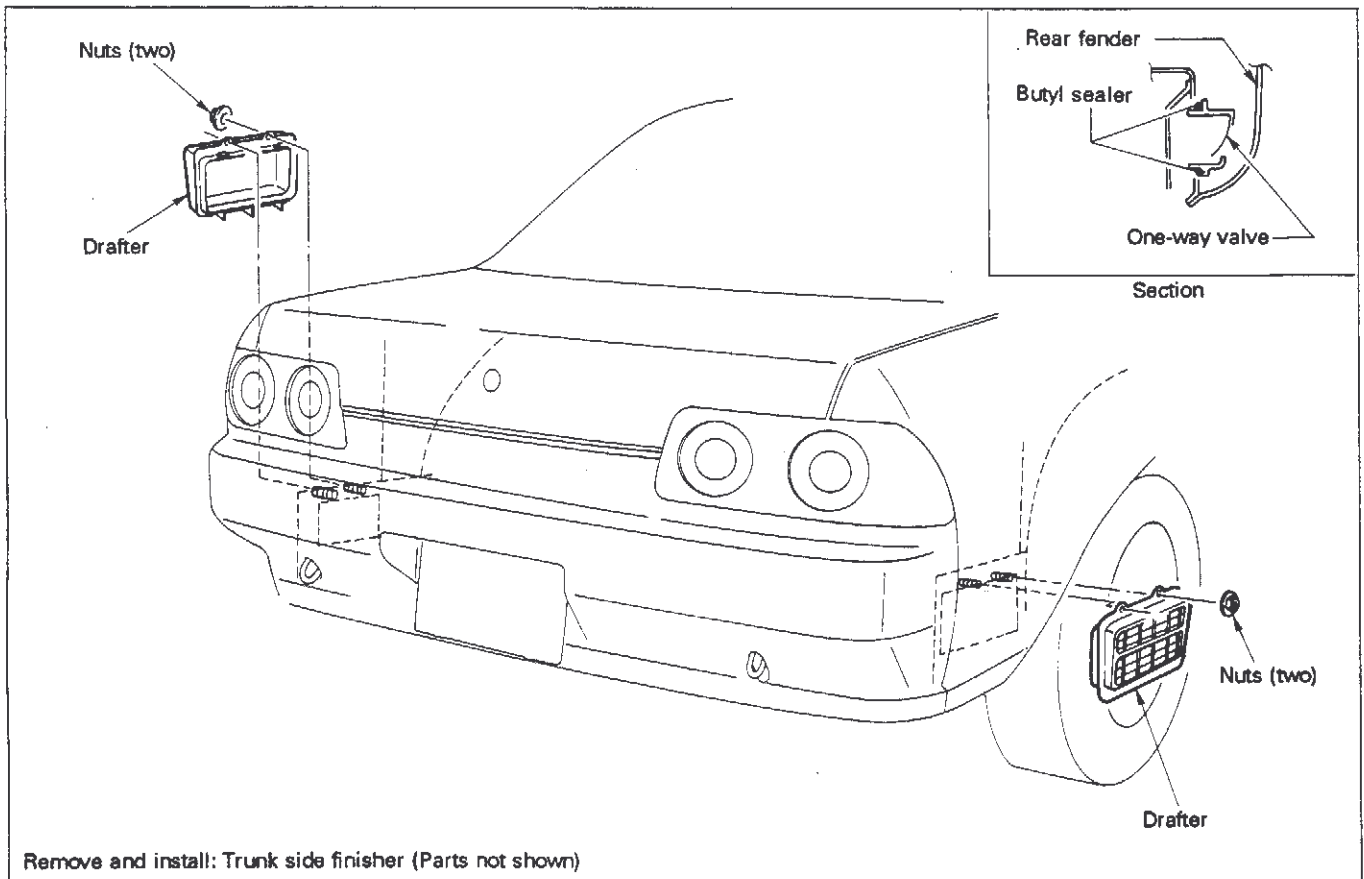

D2 BODY EXTERIOR

9. Center Mudguard and Chipping Protector (GT-R model)

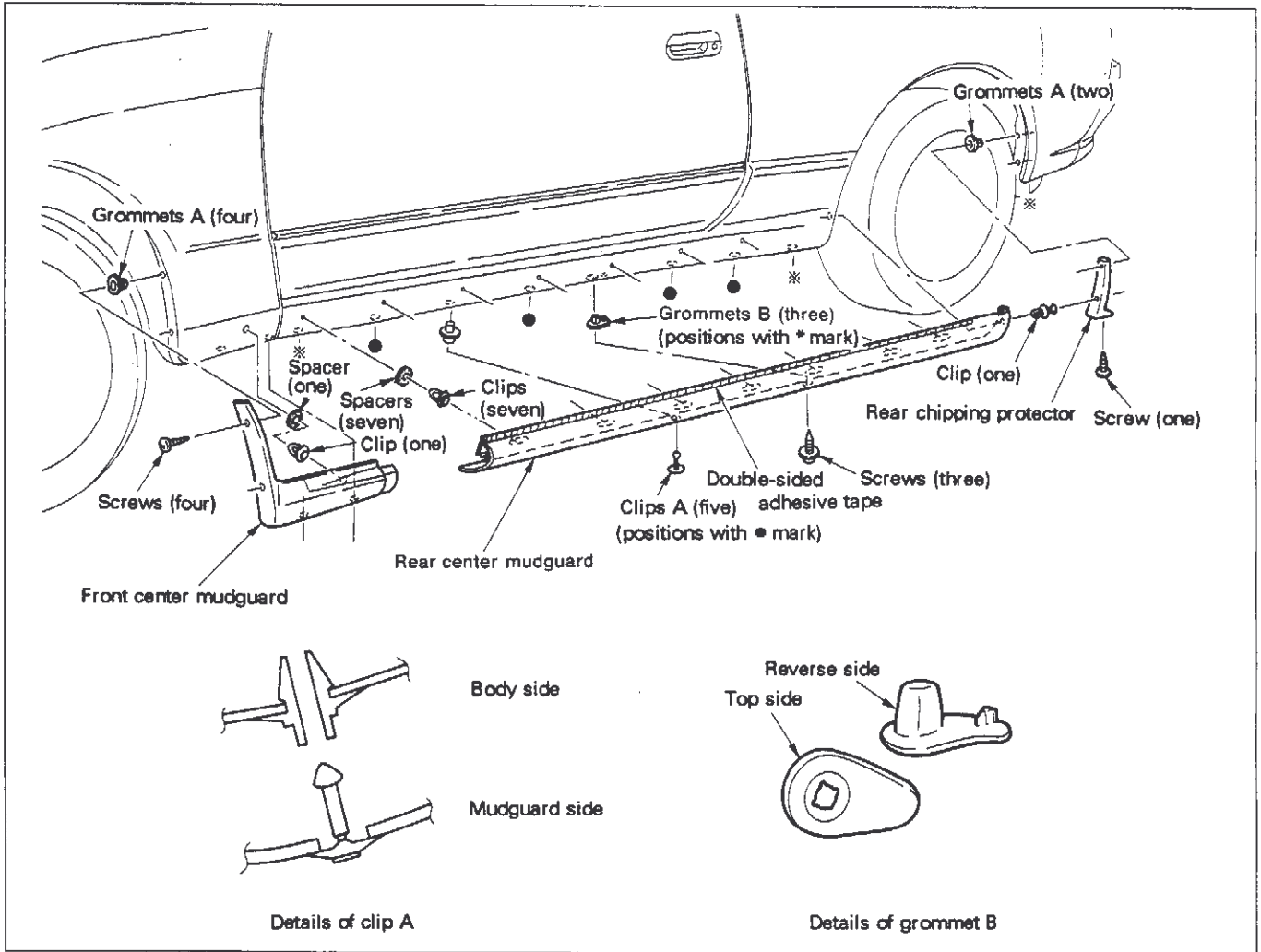

D3 OPEN-CLOSE DEVICES

1. Hood

1-1 FITTING STANDARD AND ADJUSTMENT

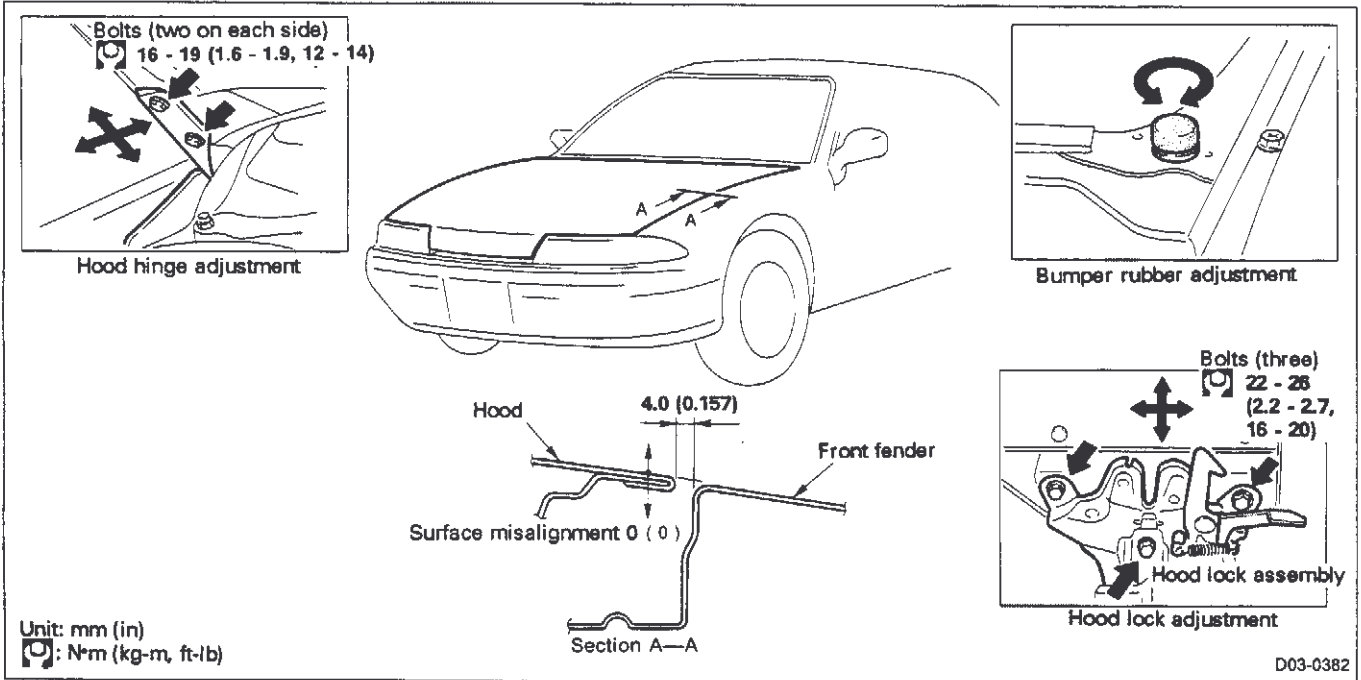

1-2 HOOD ASSEMBLY AND HOOD INSULATOR REMOVAL AND INSTALLATION

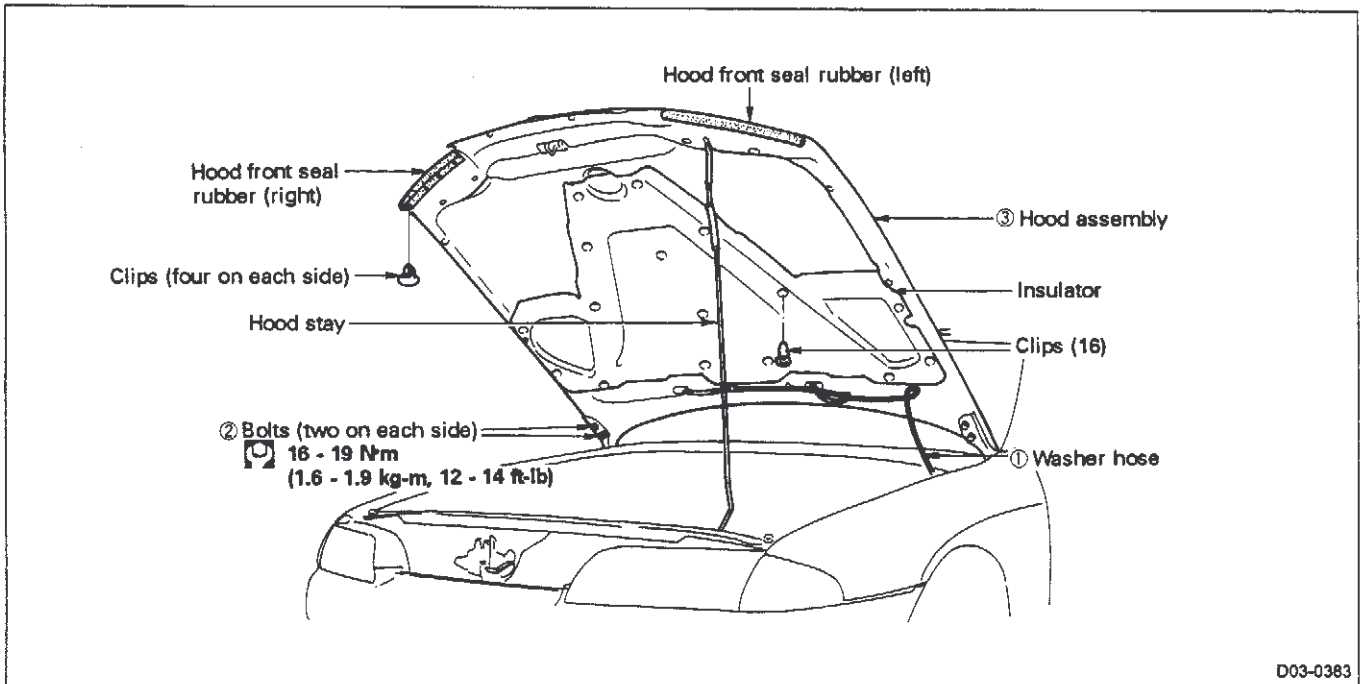

D3 OPEN-CLOSE DEVICES

1. Hood (Cont'd)

1-3 HOOD LOCK CONTROL REMOVAL AND INSTALLATION

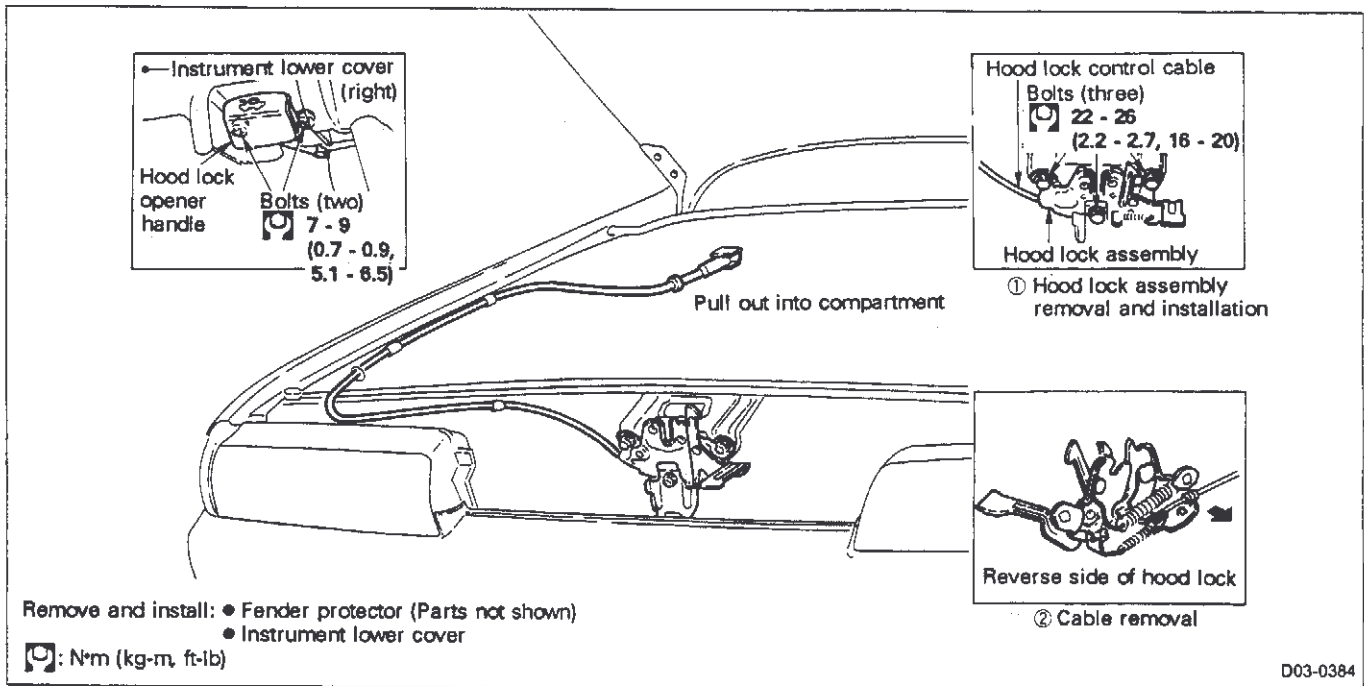

2. Door

2-1 FITTING STANDARD AND ADJUSTMENT

(1) 2-door Sports Coupe

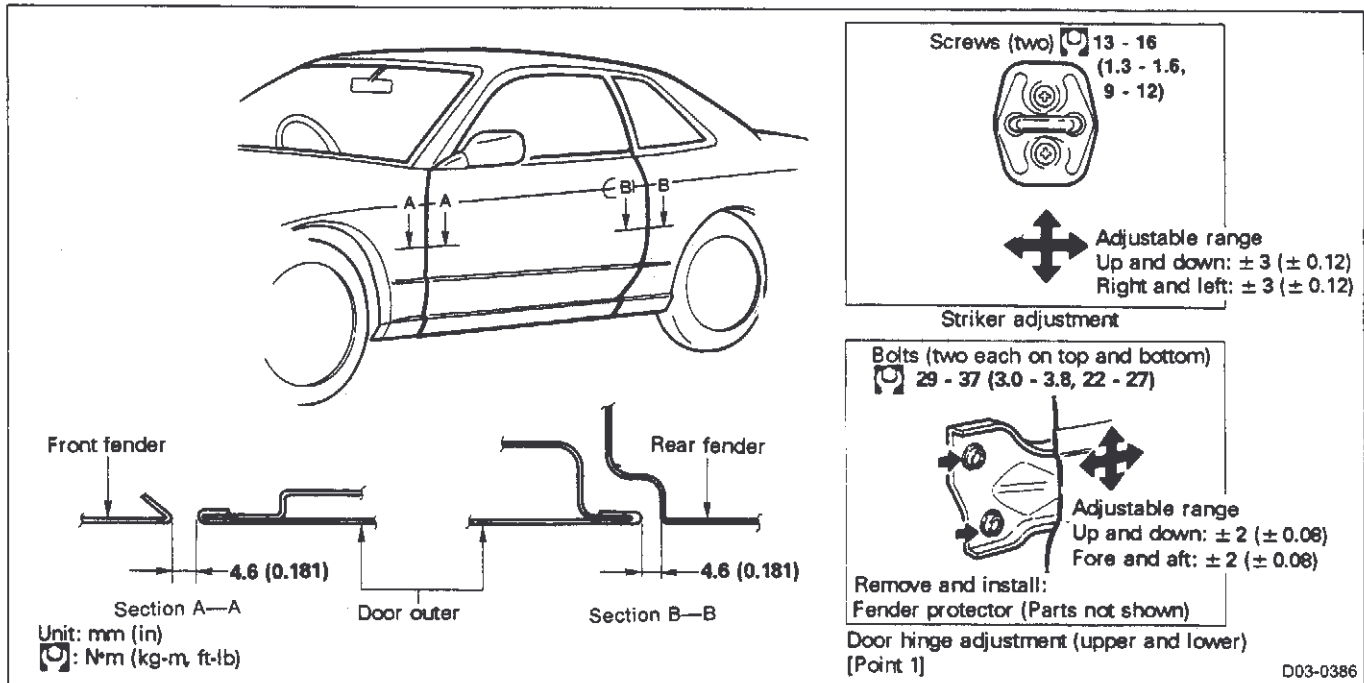

D3 OPEN-CLOSE DEVICES

2. Door (Cont'd)

[Point 1] Door hinge adjustment

Remove and install: Fender protector (Parts not shown)

- Remove fender rear end securing bolts (four), and adjust door hinge using offset wrench while lifting fender off vehicle body.

NOTES:

- (1) Pay attention not to deform fender when lifting.
- (2) Keep waste cloth inserted under upper part of fender while adjusting.

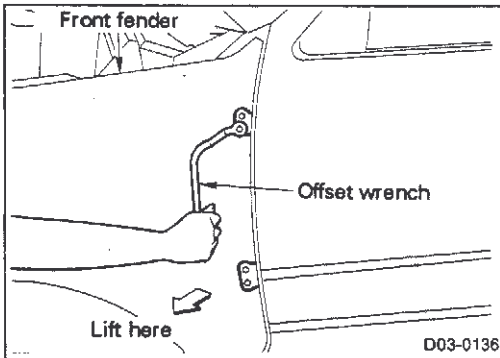

2-2 DOOR ASSEMBLY REMOVAL AND INSTALLATION

(1) Removal, installation and inspection

- To remove and install, remove check link pin and then remove door side hinge bolts (two each, upper and lower).
- When removing, pay attention not to damage coated surface.

NOTES:

- (1) When removing and installing, support door assembly using jack, cushioned with waste cloth to prevent damage to door.
- (2) Check door hinge for the following points:
Abnormality or large resistance during opening or closing ... Apply grease
Damage or wear on components ... Replace
- (3) Replace check link if damaged or worn abnormally.
- (4) Install check link with RH or LH identification mark facing up.
- (5) Apply "Nissan body grease" to rotating part of hinge and to check link pin.

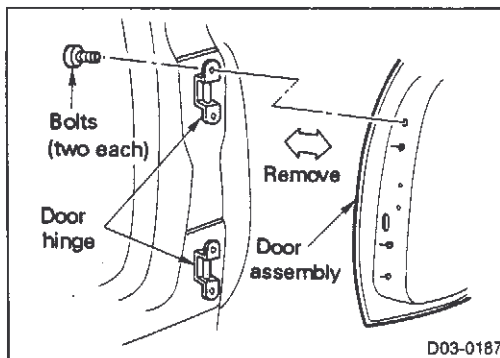
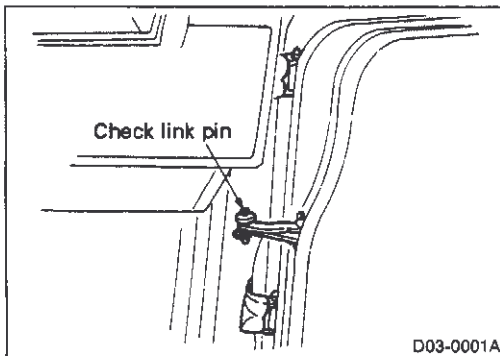

D3 OPEN-CLOSE DEVICES

2. Door (Cont'd)

2-3 FRONT DOOR TRIM REMOVAL AND INSTALLATION

(1) 2-door Sports Coupe

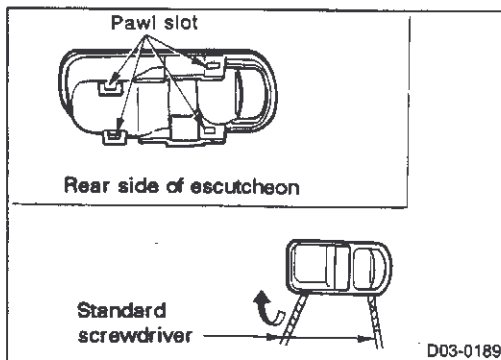
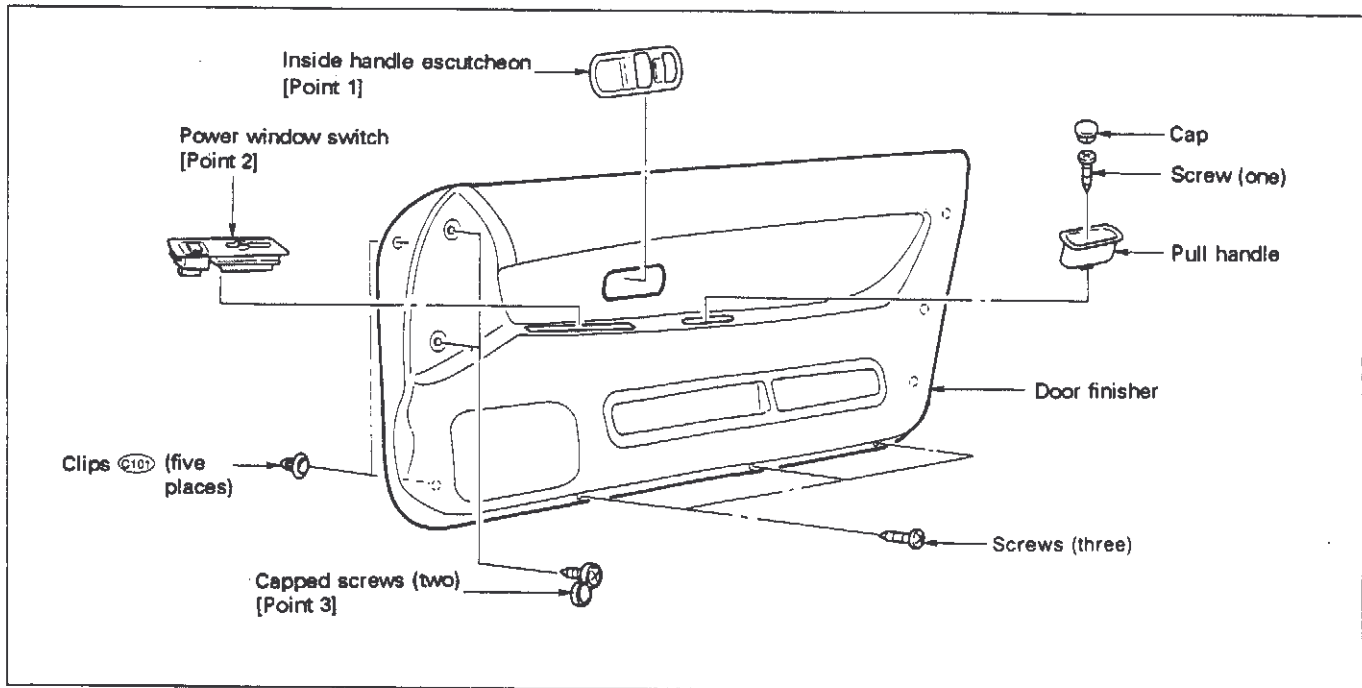

[Point 1] Inside handle escutcheon removal

- Using standard screwdriver wrapped with vinyl tape, remove escutcheon by disengaging upper and lower pawls.

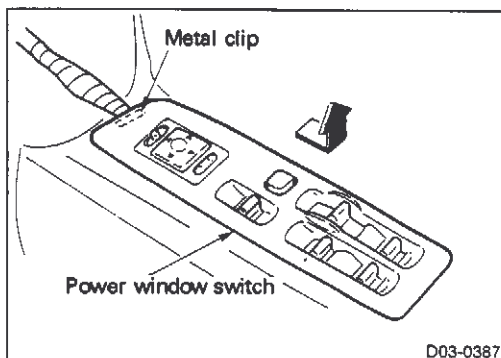

[Point 2] Power window switch removal

- Insert standard screwdriver tip to front end, and push screwdriver rearward to disengage metal clip, and then remove power window switch.

D3 OPEN-CLOSE DEVICES

2. Door (Cont'd)

[Point 3] Capped screw removal

- Using standard screwdriver, open screw head cap, and then remove screw.

NOTE:

Cap is made integral with screw. Pay attention not to tear off cap from cap base when removing screw.

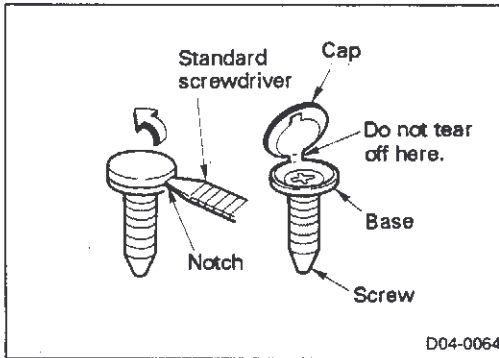

2-4 FRONT DOOR LOCK AND REMOTE CONTROL REMOVAL AND INSTALLATION

(1) 2-door Sports Coupe

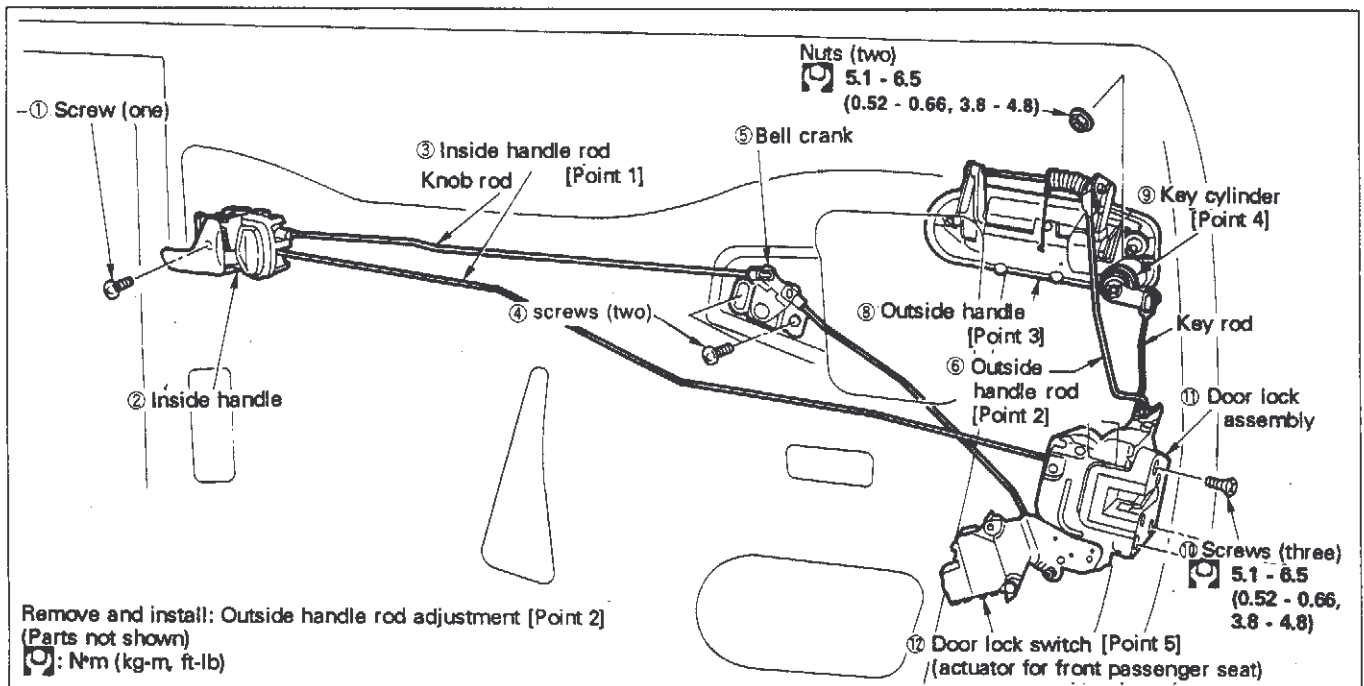

[Point 1] Inside handle rod adjustment

- Fix door lock and inside handle, and adjust bell crank in direction of arrow shown at left to eliminate rod play, then secure with screws.

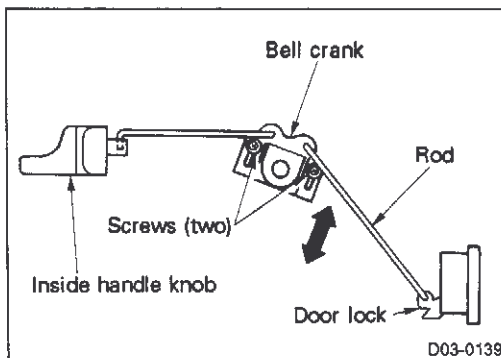

D3 OPEN-CLOSE DEVICES

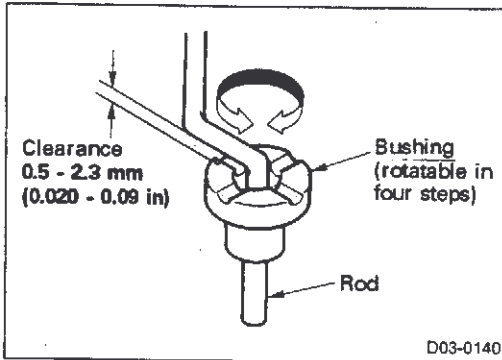

2. Door (Cont'd)

[Point 2] Outside handle rod adjustment

- Rotate bushing so that clearance between bushing and rod meets specification shown at left.

NOTE:

Clearance must be greater than 0 mm (0 in), or outside lever must be free when not being operated.

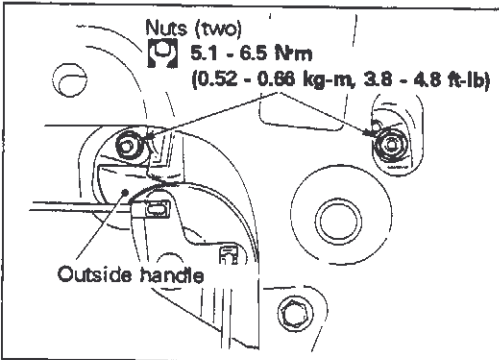

[Point 3] Outside handle single part removal

Removal

- Completely close window.
- Disconnect key cylinder rod and outside handle rod connections.
- Remove two nuts and remove outside handle.

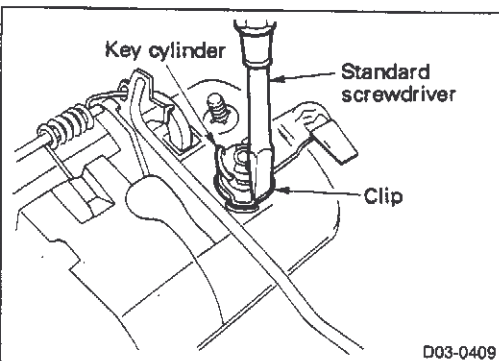

[Point 4] Key cylinder removal and installation

Removal

- Insert tip of small standard screwdriver into clearance between clip and key cylinder to disengage clip, and remove key cylinder.

Installation

- Install clip to key cylinder case, and then insert key cylinder.

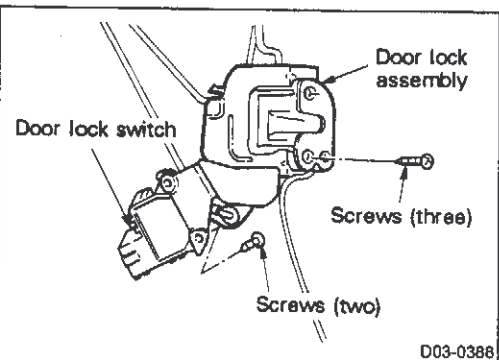

[Point 5] Door lock switch removal

Remove and install: Inside and outside handle rods, key cylinder rod (Part not shown)

- Remove rod, and remove door lock assembly screws (three) and door lock switch bolt (one), and then remove door lock assembly.
- Remove screws (two) to separate door lock assembly from door lock switch.

NOTE:

Door lock switch cannot be removed from door lock assembly if the assembly is installed on vehicle. Be sure to remove door lock switch together with door lock assembly.

D3 OPEN-CLOSE DEVICES

2. Door (Cont'd)

2-5 FRONT DOOR WINDOW AND REGULATOR REMOVAL AND INSTALLATION

(1) 2-door Sports Coupe

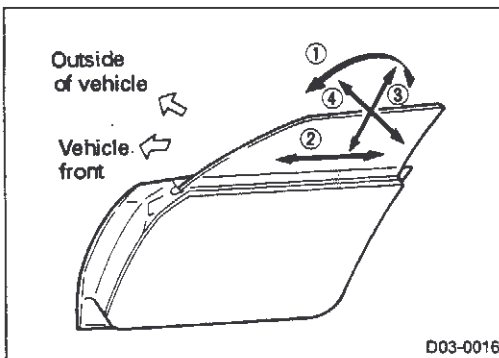
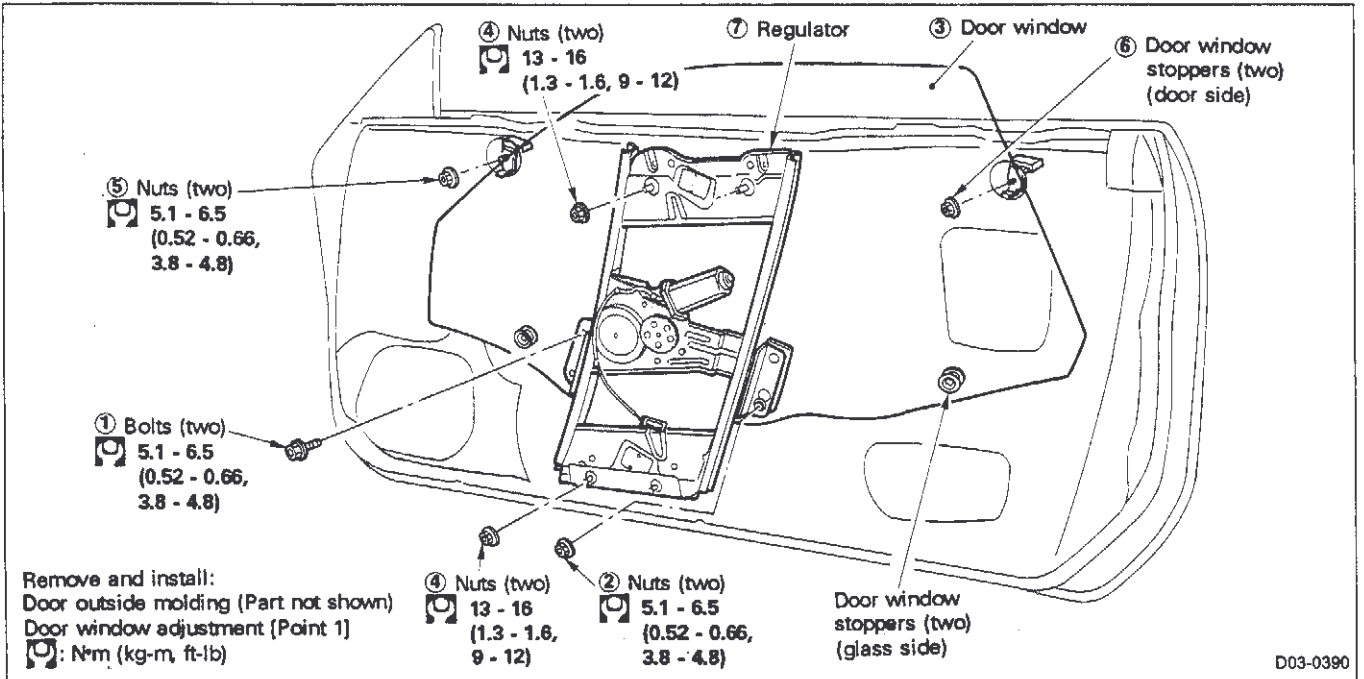

[Point 1] Door window adjustment

- Door window fitting can basically be adjusted by moving window in four directions as shown below.
- ① Window position (front-end down, rear-end down)
- ② Fore and aft adjustment of window
- ③ Vertical adjustment of window (upper limit)
- ④ Right and left adjustment of window (inward or outward inclination)
- Perform adjustment at the positions shown below.

D3 OPEN-CLOSE DEVICES

2. Door (Cont'd)

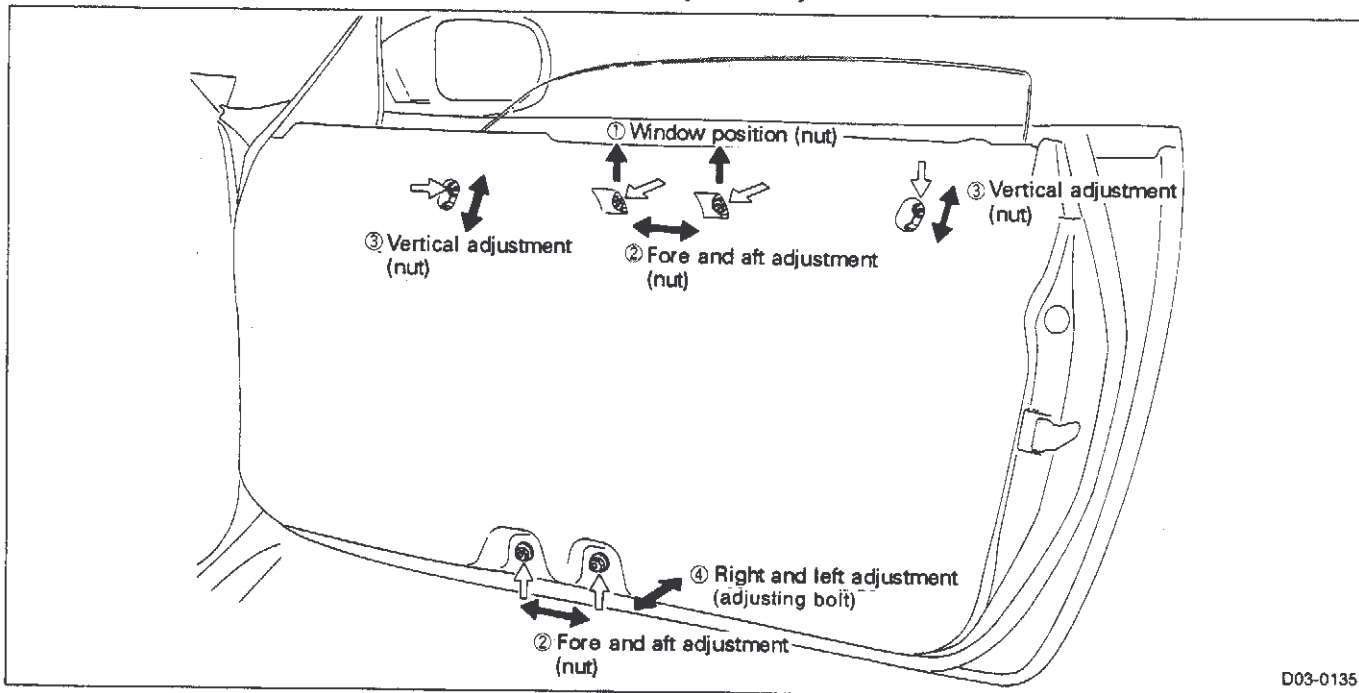

Adjustment work

- To adjust door window position, proceed as follows:

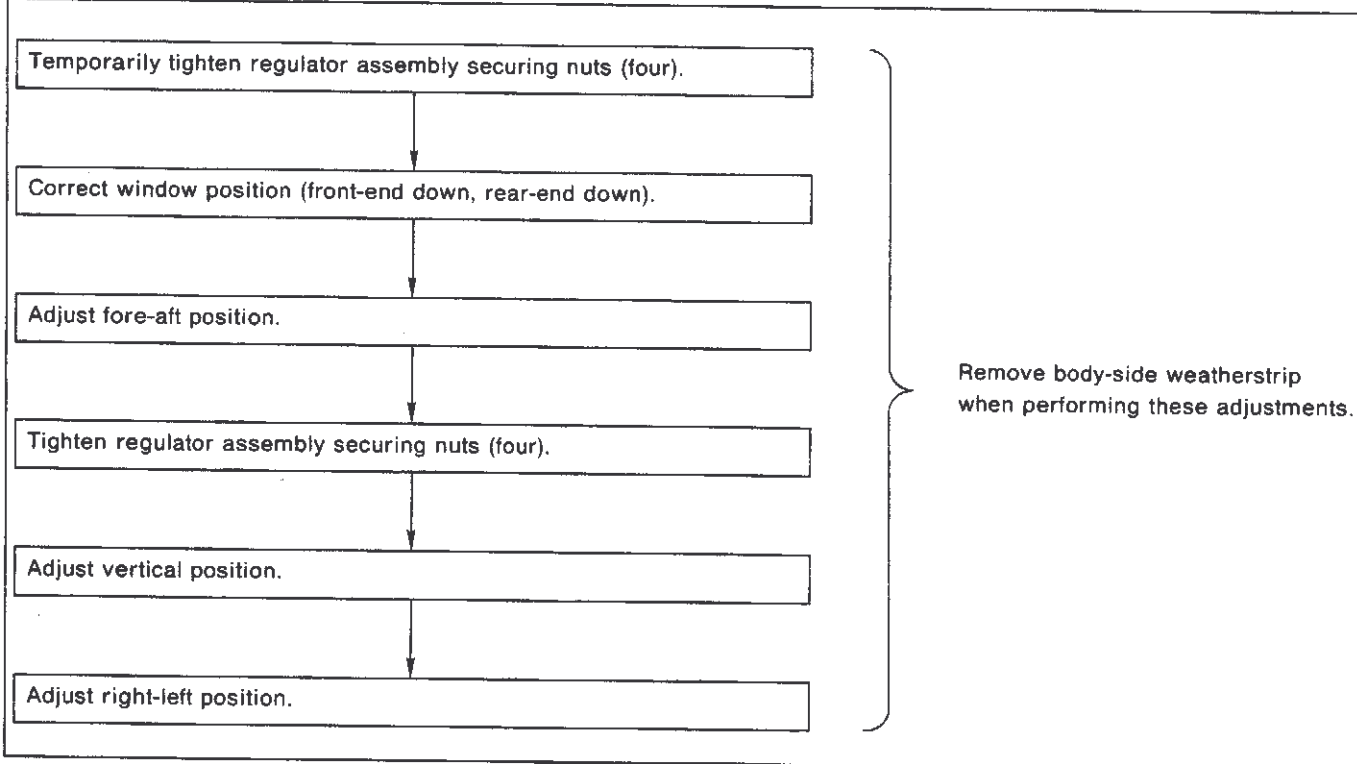

D3 OPEN-CLOSE DEVICES

2. Door (Cont'd)

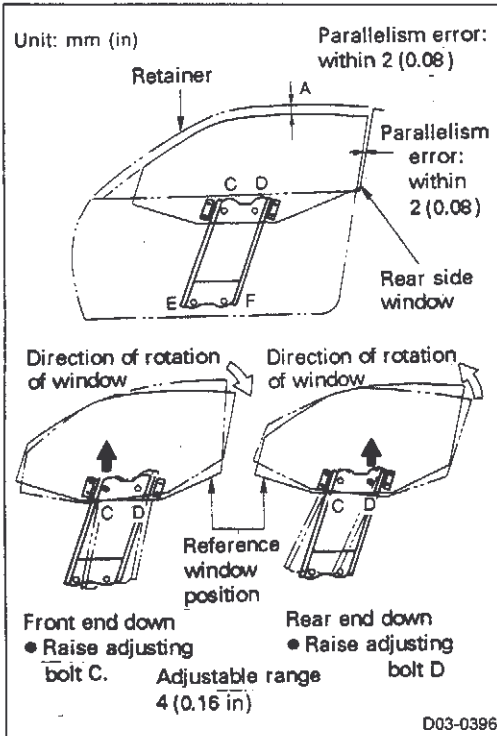

① Window position adjustment

Remove and install: Body side weatherstrip (Part not shown)

NOTE:

Perform this position adjustment simultaneously with fore-aft adjustment in step ②.

- With window raised, loosen securing bolts C, D, E, and F, and adjust inclination of window using bolts C and D so that a uniform clearance will be obtained between window and retainer at positions A and B.

Window front end down:	Raise adjustment bolt C using bolt D as supporting point.
Window rear end down:	Raise adjustment bolt D using bolt C as supporting point.

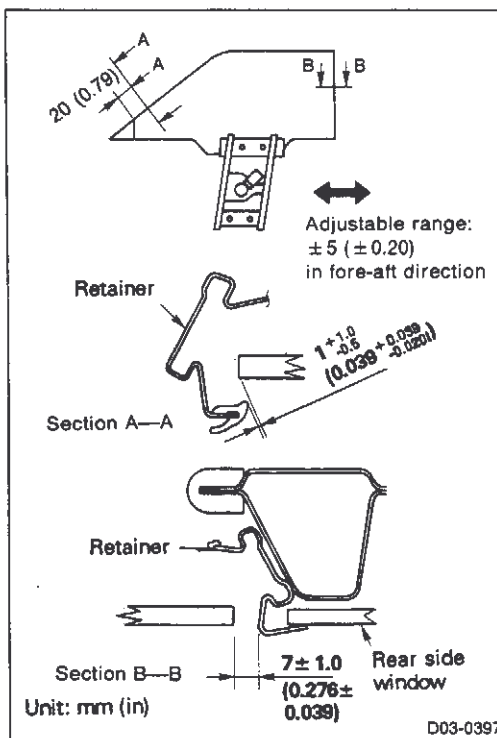

② Fore-aft adjustment of window

- Loosen bolts [C, D, E, and F shown in step ① above] and slide regulator in fore-aft direction so that clearance between rear end of window and retainer meet standard shown at left, then temporarily secure bolts by tightening nuts.

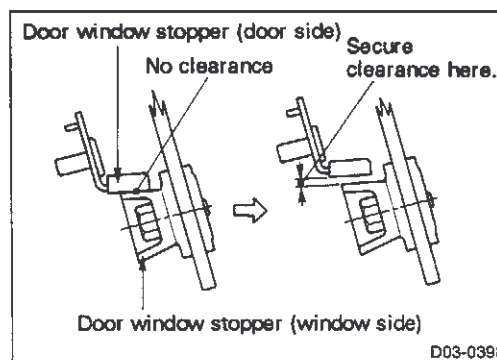

- When adjusting, slightly lower window to create clearance between door side stopper and window side stopper.

NOTE:

Do not lower window excessively.

D3 OPEN-CLOSE DEVICES

2. Door (Cont'd)

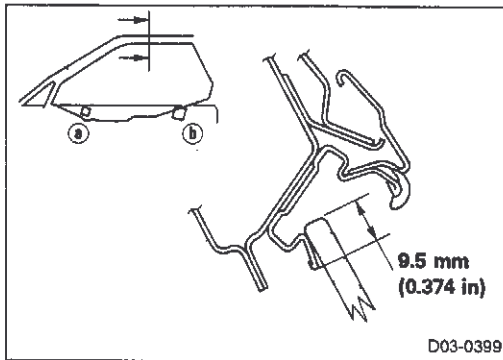

③ Vertical adjustment of window

- With window fully closed, adjust height of door window stoppers (door side) **a** and **b** so that retainer lower end and window top end positions meet specification shown at left, then secure stoppers with nuts.

④ Right and left adjusting of window

- Use lower two of four adjusting bolts.

NOTES:

- (1) Rotate adjusting bolt in CW direction, and end of window will move outward. Rotate adjusting bolt in CCW direction, and end of window will move inward.
- (2) Slightly lower window, like in the case of fore-aft adjustment, to create a clearance between door side stopper and window side stopper.

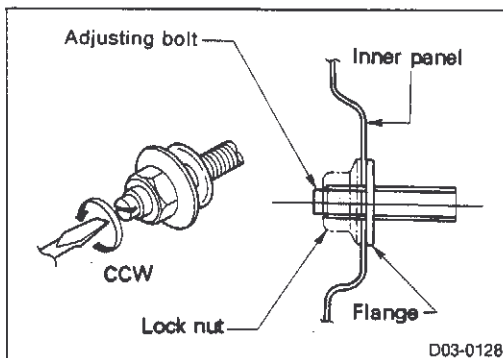
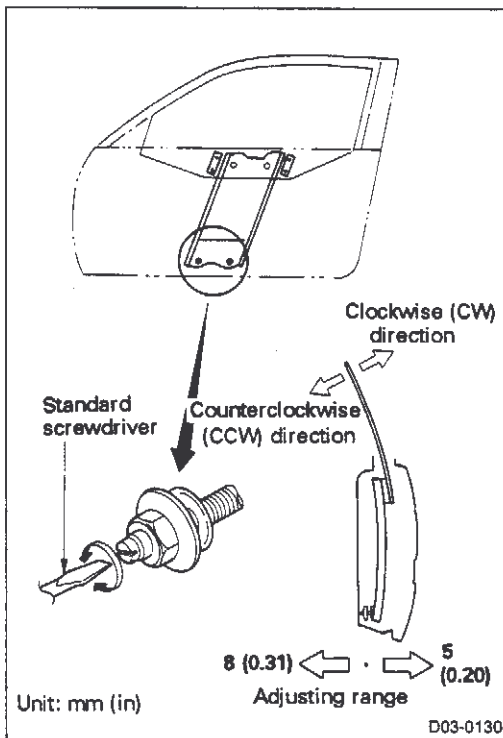

- Loosen nuts (front and rear), and loosen adjusting bolt and tilt window fully inward until adjusting bolt flange contacts inner panel.

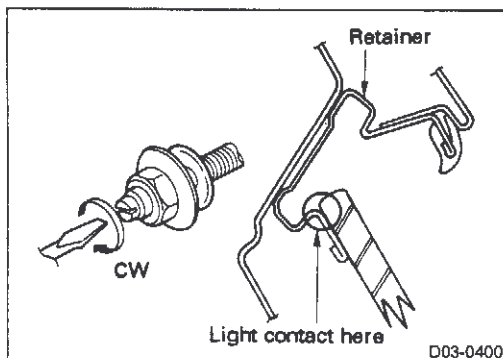

- With door fully closed in the above-mentioned position, tighten adjusting bolts a few turns until inside of window lightly contacts retainer.

NOTE:

- Evenly tighten front and rear adjusting bolts.**

D3 OPEN-CLOSE DEVICES

2. Door (Cont'd)

- After completing adjustment, tighten lock nut securely.

NOTE:

When tightening lock nut, hold adjusting bolt using standard screwdriver to prevent rotation.

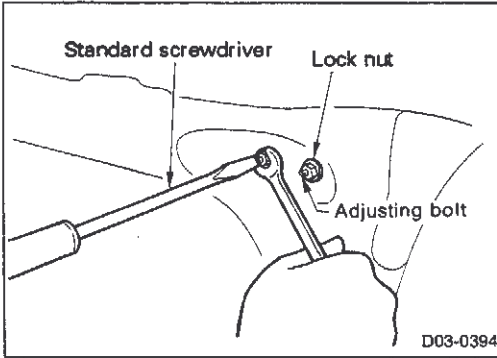

2-6 POWER DOOR LOCK TROUBLE DIAGNOSIS

(1) Outline of trouble diagnosis (2-door Sports Coupe)

Carry out trouble diagnosis according to flowchart.



- Prepare the following tools and equipment for trouble diagnosis.
Analog circuit tester
Sub harness and battery (for checking door lock actuator operation)
Tools for removing and installing parts (screwdriver, wrenches, etc.)
- Carry out the following inspection when diagnosing.
*1: Door lock timer connector disconnected
*2: Door lock actuator connector disconnected
*3: Door lock knob and key cylinder interlocking switch disconnected, or rod disconnected, and bell crank installed.

(2) Components

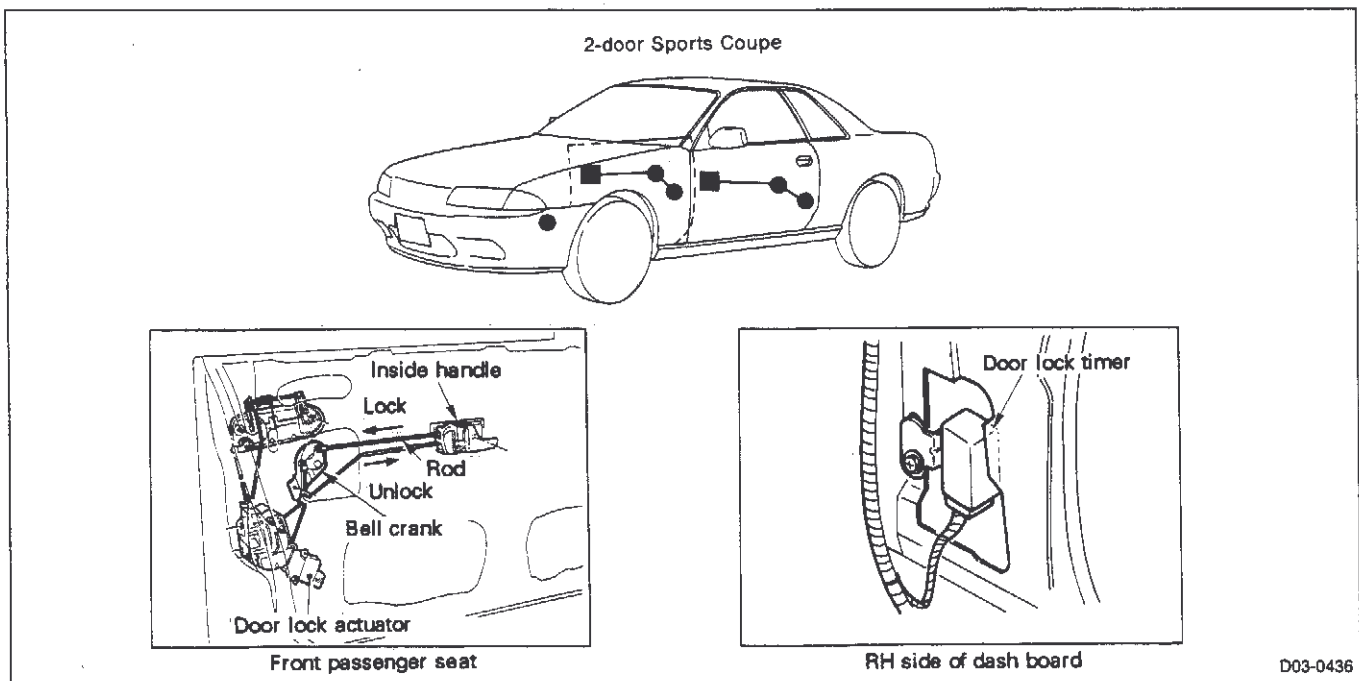

D3 OPEN-CLOSE DEVICES

2. Door (Cont'd)

(3) System diagram

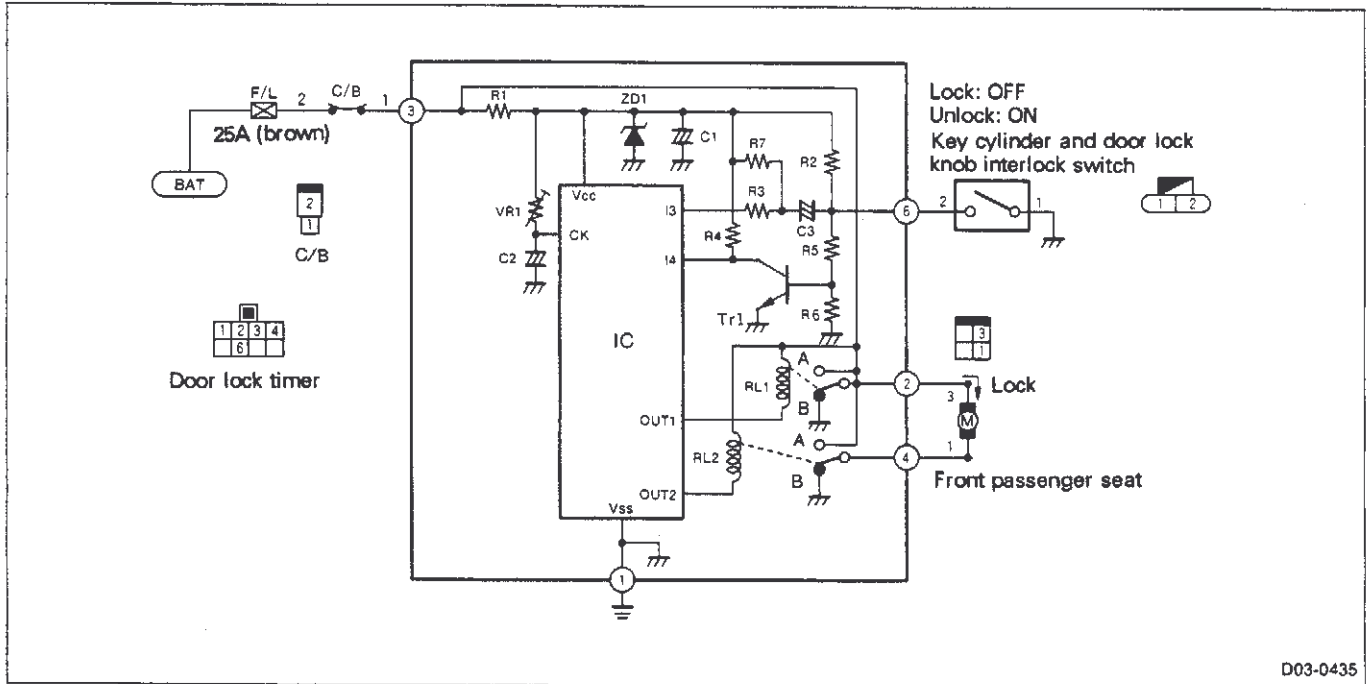

D03-0435

D3 OPEN-CLOSE DEVICES

2. Door (Cont'd)

(4) Diagnostic chart

- Front passenger seat door lock fails to operate.

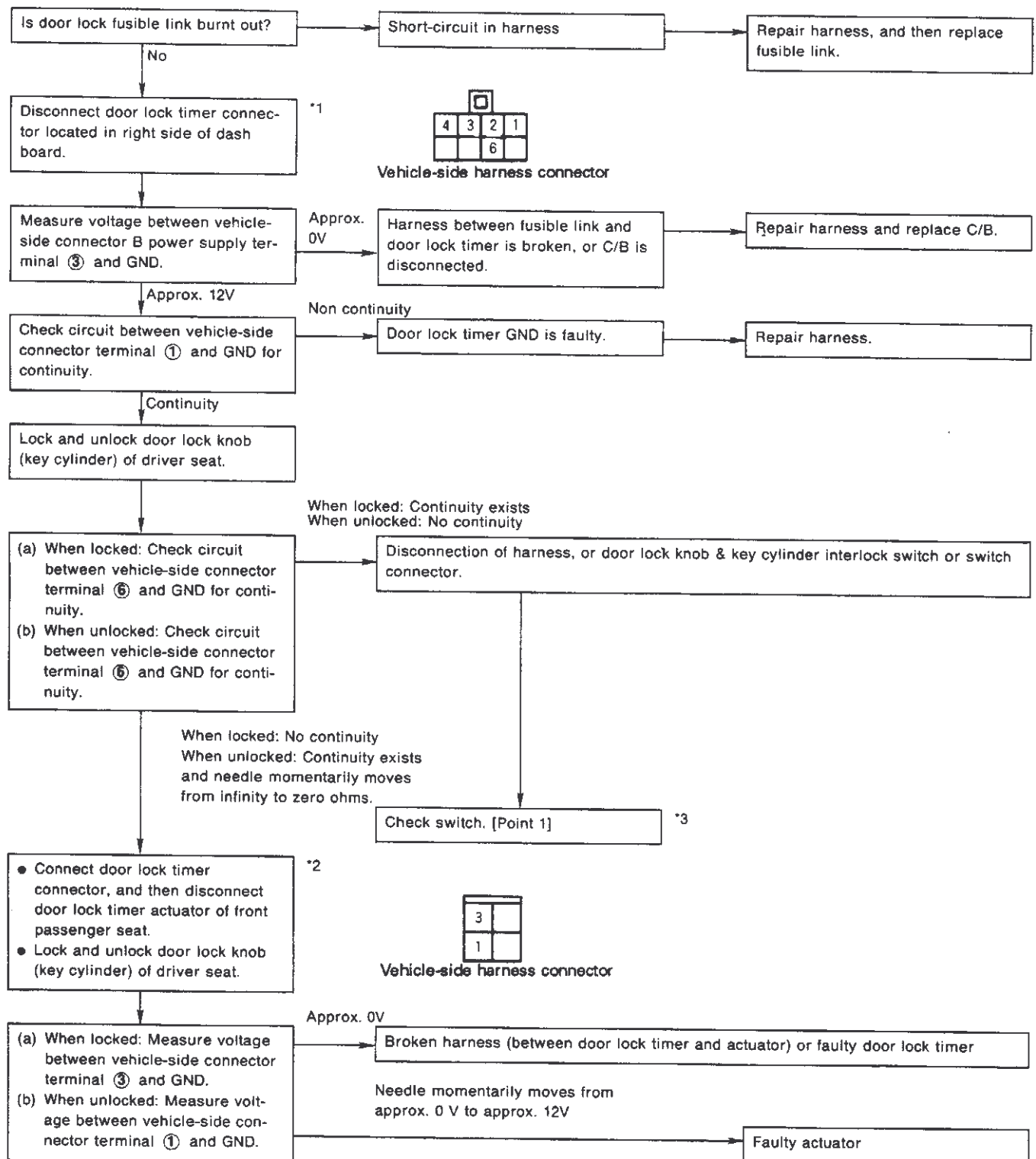

D3 OPEN-CLOSE DEVICES

2. Door (Cont'd)

[Point 1] Continuity test on switch

- Manually move rod and check for continuity between terminals. If continuity exists, tester needle will momentarily move from infinity side to zero ohm side.

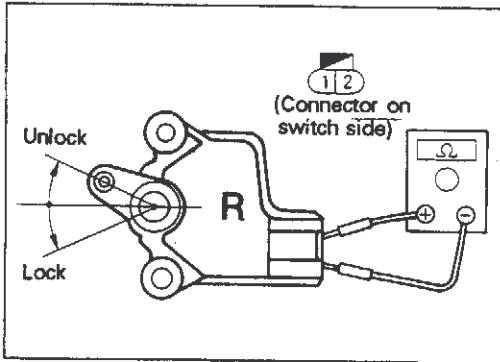

2-7 POWER WINDOW TROUBLE DIAGNOSIS

(1) Outline of trouble diagnosis (2-door Sports Coupe)

- Troubles on vehicle are classified into four large categories, and trouble diagnosis is performed according to flowchart for each category.
- Trouble diagnostic conditions are: ignition switch ON and power window lock switch in UNLOCK position.

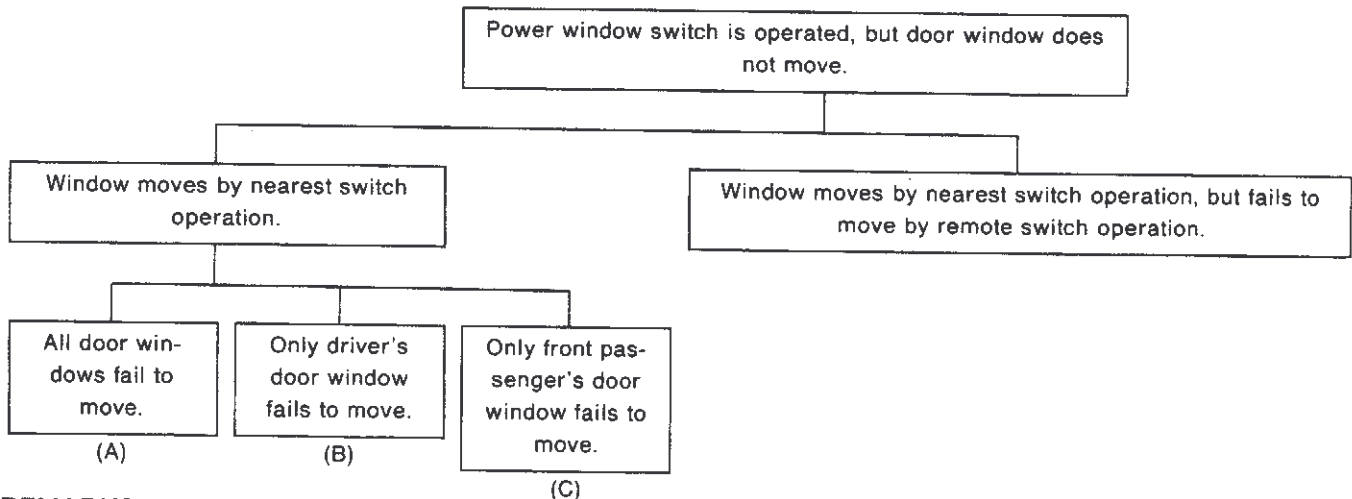

REMARKS:

Nearest switch operation: Attempt to operate door window by operating its nearest power window switch.

Remote switch operation: Attempt to operate front passenger door window by operating power window main switch by driver seat.

- Caution during Trouble Diagnosis**
Trouble diagnosis is performed with ignition switch set ON. When repairing trouble, be sure to disconnect battery negative terminal.

D3 OPEN-CLOSE DEVICES

2. Door (Cont'd)

(2) System diagram

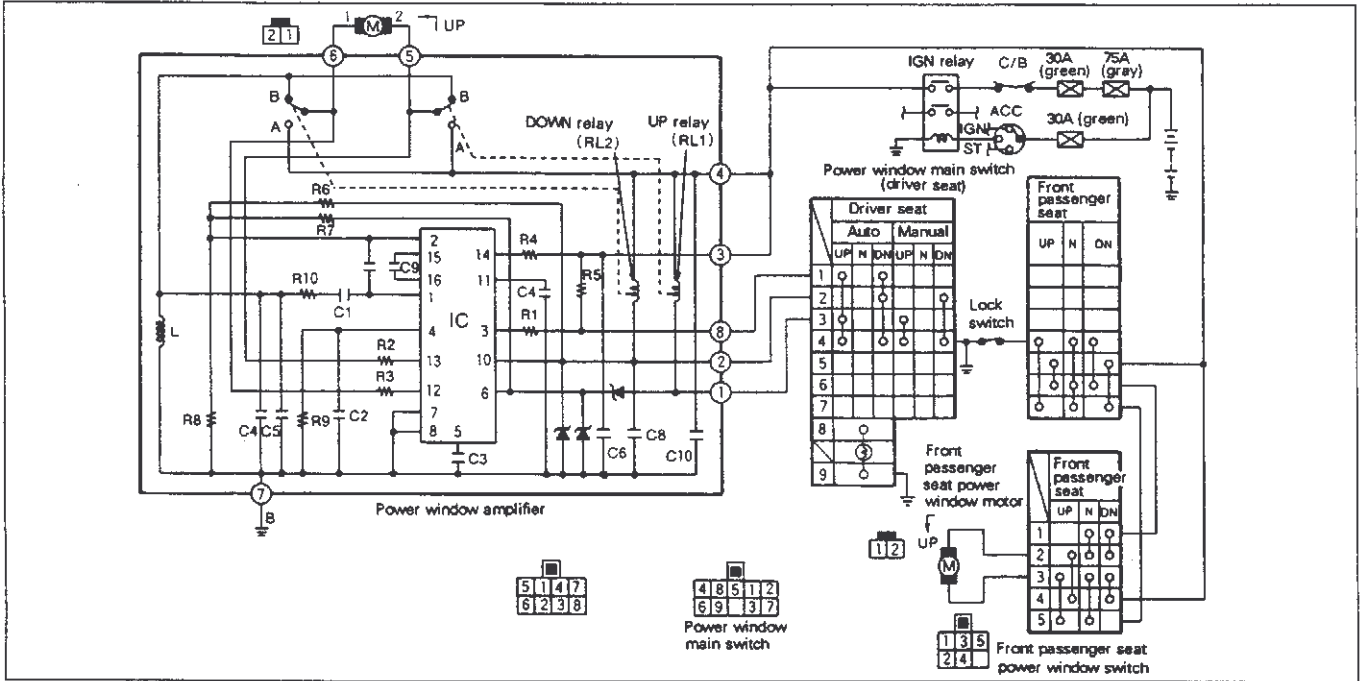

D3 OPEN-CLOSE DEVICES

2. Door (Cont'd)

(3) Diagnostic chart

(A) No door window moves using respective power window switch

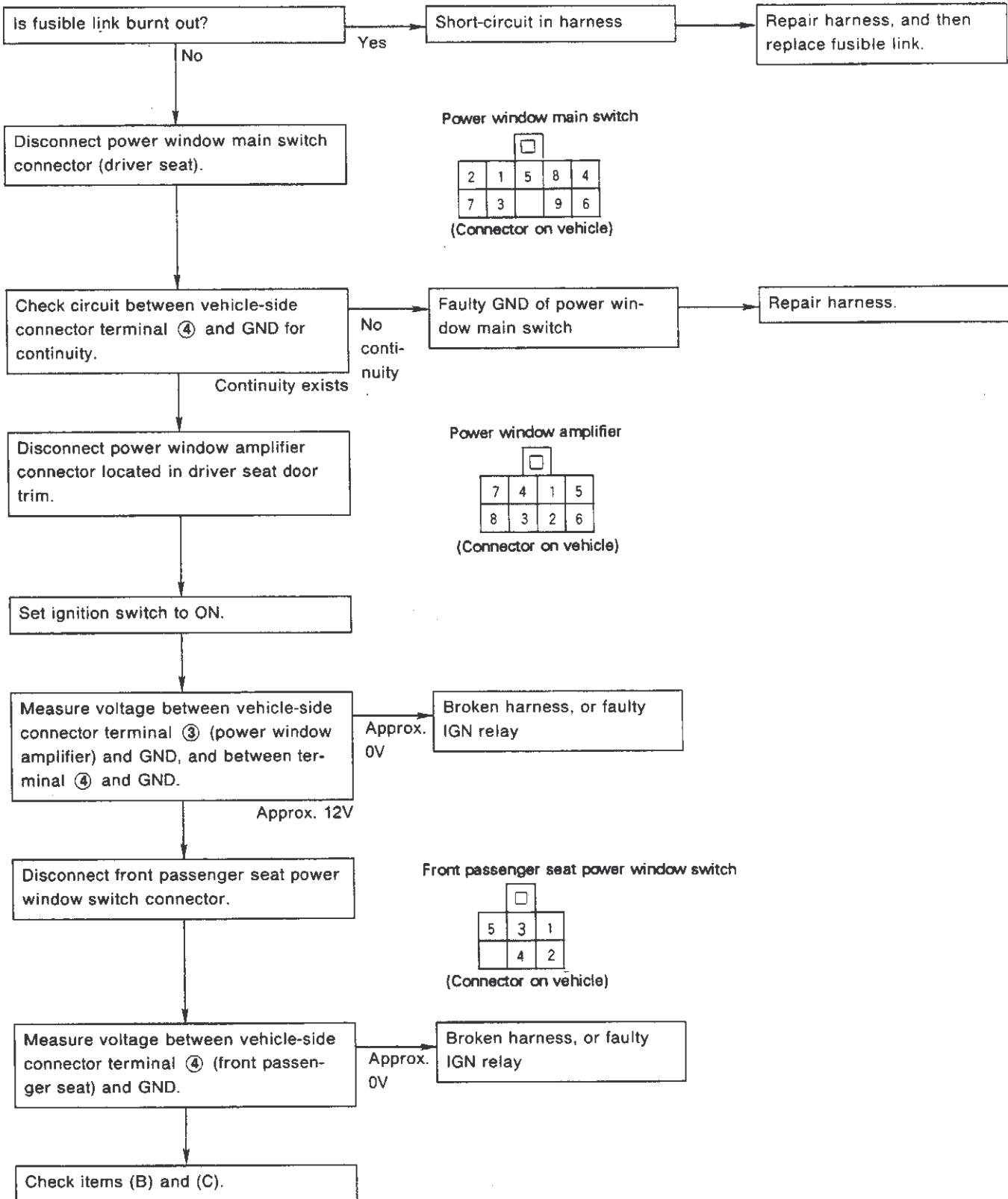

D3 OPEN-CLOSE DEVICES

2. Door (Cont'd)

(B) Unable to operate driver seat window alone

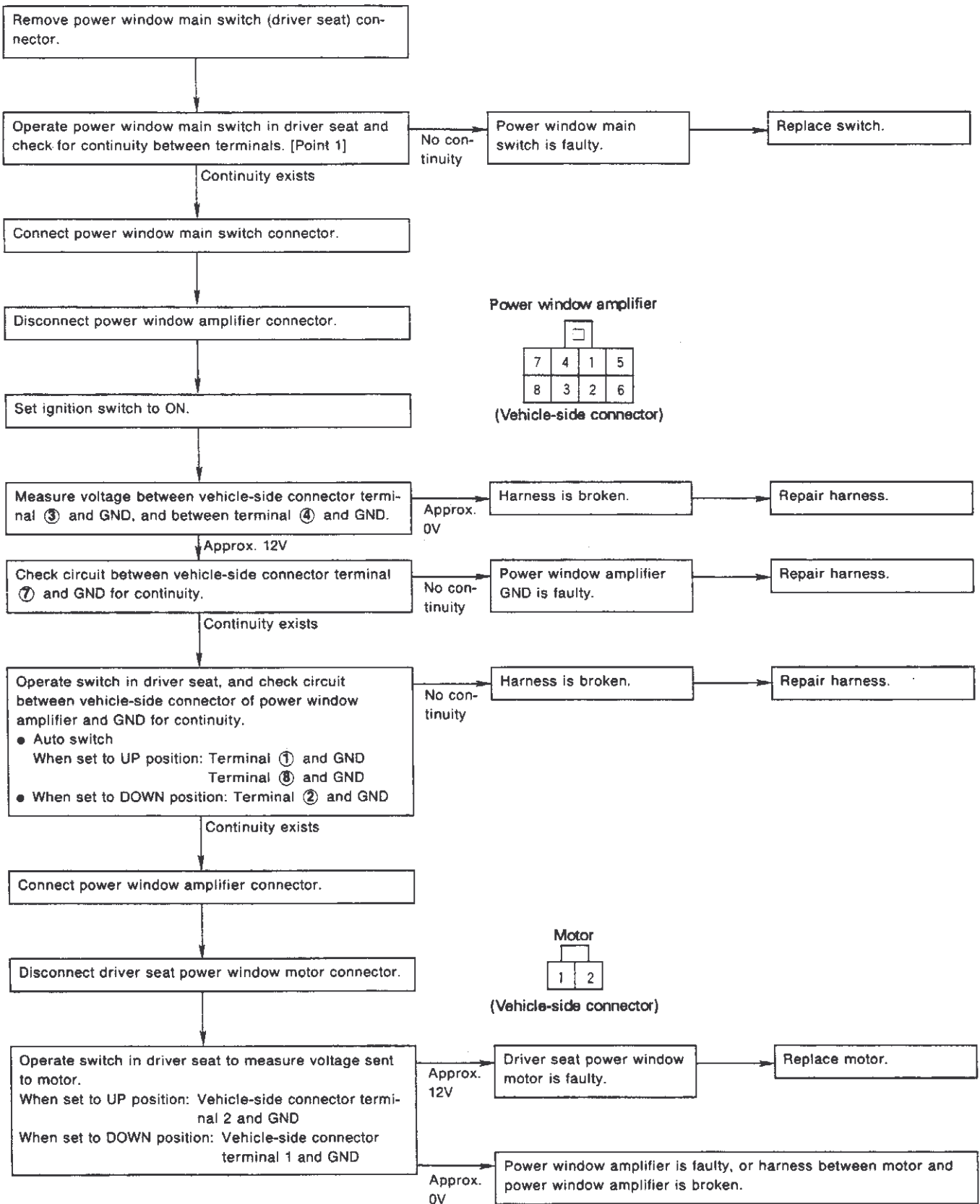

D3 OPEN-CLOSE DEVICES

2. Door (Cont'd)

(C) Unable to operate front passenger seat window using the switch on that door

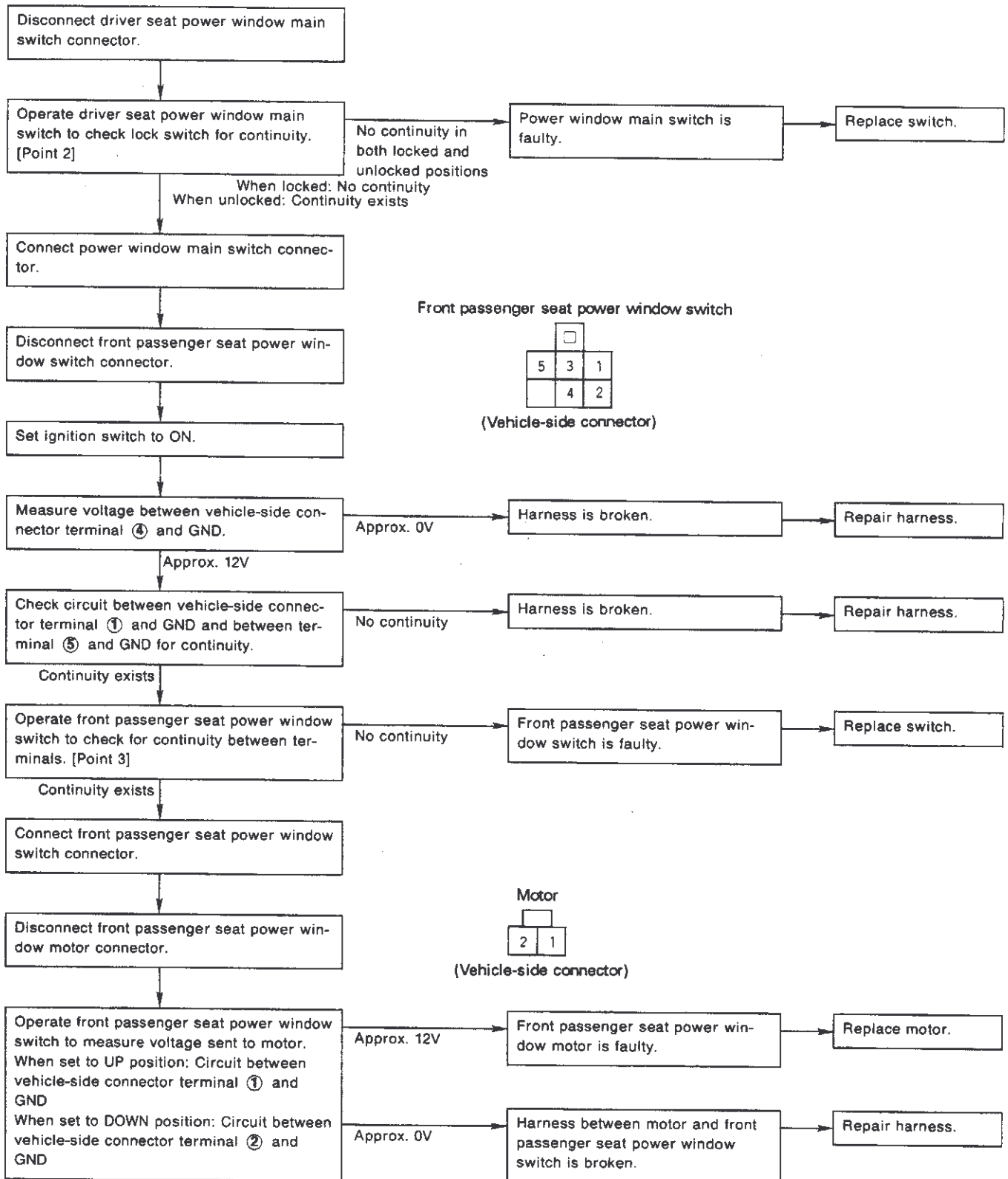

D3 OPEN-CLOSE DEVICES

2. Door (Cont'd)

(D) Front passenger seat window will operate with the switch on that door, but will not operate with remote switch.

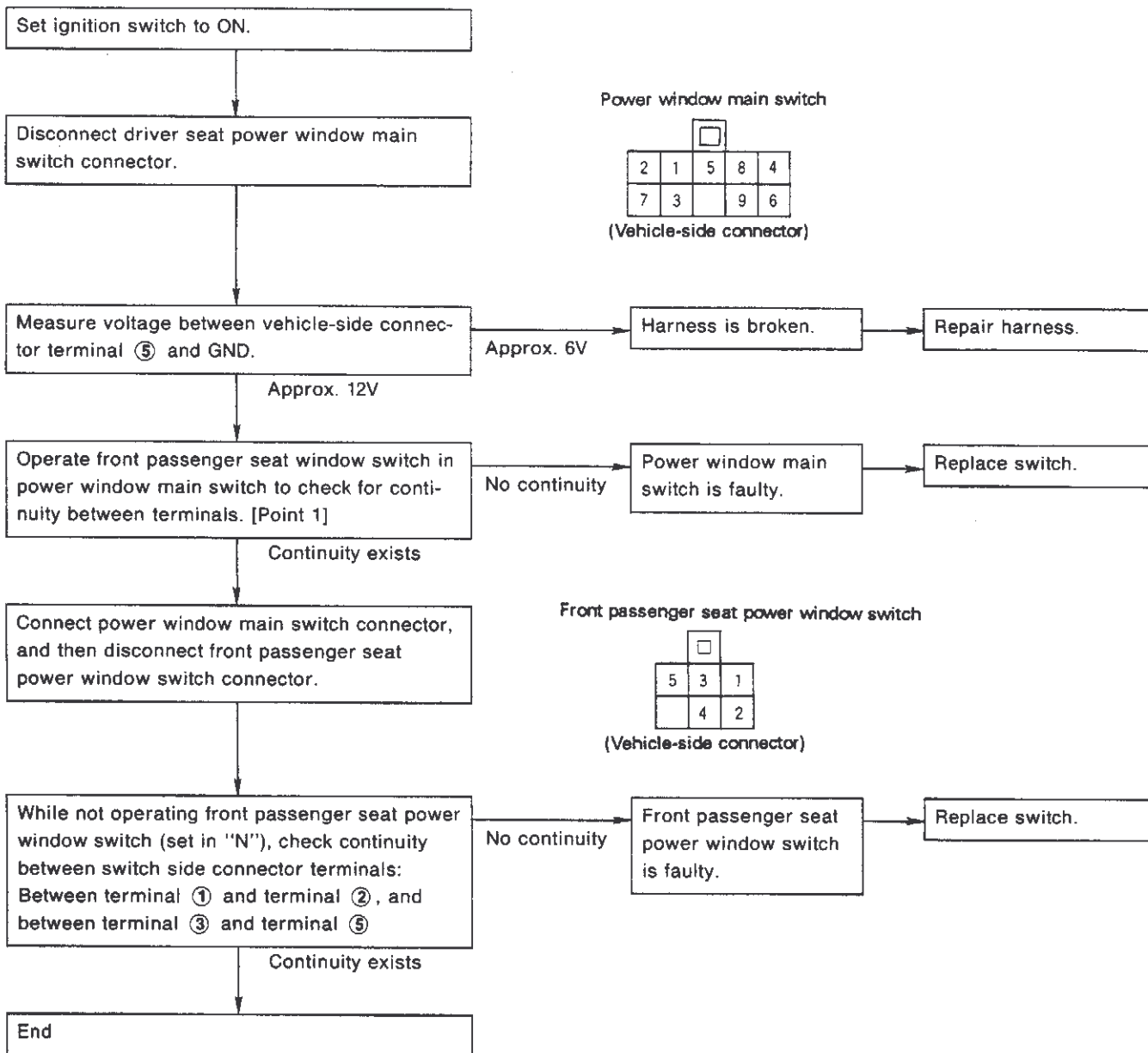

D3 OPEN-CLOSE DEVICES

2. Door (Cont'd)

[Point 1] Power window main switch continuity inspection

- Set power window lock switch in locked position (with lock button pressed), and operate driver seat and front passenger seat switches to check continuity between respective terminals using circuit tester.

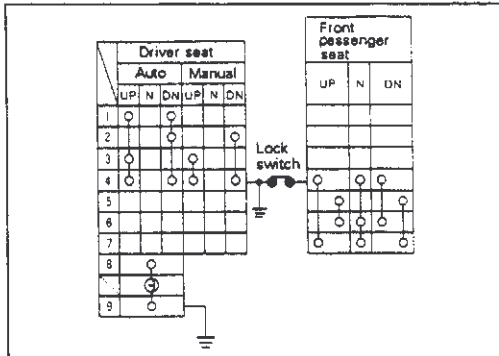
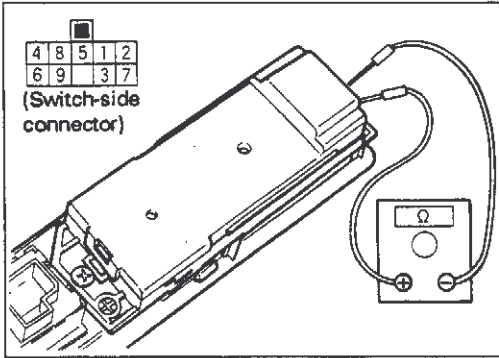

[Point 2] Power window lock switch continuity inspection

- Set lock switch in unlocked position (with lock button not depressed), and press DOWN end of driver seat manual switch. Check continuity between terminals ② and ⑦ using circuit tester.

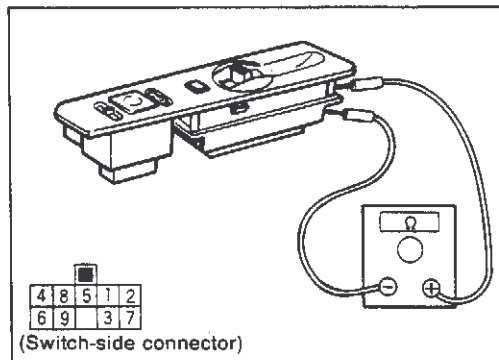

[Point 3] Continuity inspection of front passenger seat power window switch

- Operate switch in each position, and check continuity between respective terminals using circuit tester.

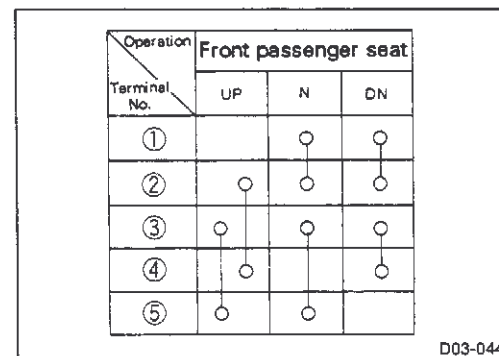
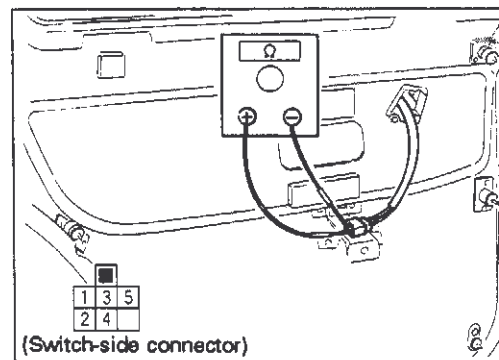

D03-0444

D3 OPEN-CLOSE DEVICES

3. Trunk Lid

3-1 FITTING STANDARD AND ADJUSTMENT

Unit: mm (in)
[Torque symbol]: N·m (kg-m, ft-lb)

Section A—A
 4.0 (0.157) Trunk lid
 Height difference: within 1.0 (0.039)
 Rear fender

Section B—B
 5.0 (0.197) Rear window molding
 Trunk lid

Inset 1:
 Bolts (two on each side)
 5.1 - 6.5 (0.52 - 0.66, 3.8 - 4.8)
 Remove and install: Trunk lid insulator (Parts not shown)
 Trunk lid fitting adjustment

Inset 2:
 Bolts (two)
 5.1 - 6.5 (0.52 - 0.66, 3.8 - 4.8)
 Adjustable range
 Up and down: ± 3 (± 0.12)
 Right and left: ± 3 (± 0.12)
 Striker adjustment

D03-0428

3-2 TRUNK LID ASSEMBLY

Retainer clip
Key cylinder
Trunk lid lock
 Bolts (two)
 5.1 - 6.5 (0.52 - 0.66, 3.8 - 4.8)

Trunk lid
Torsion bar

Inset 1:
 Bolts (two)
 5.1 - 6.5 (0.52 - 0.66, 3.8 - 4.8)
 Torsion bar removal and installation

Inset 2:
 Bolts (two)
 5.1 - 6.5 (0.52 - 0.66, 3.8 - 4.8)
 Remove and install: Rear parcel shelf finisher (Part not shown)
 Trunk lid hinge removal and installation

[Torque symbol]: N·m (kg-m, ft-lb)

D03-0429

D3 OPEN-CLOSE DEVICES

3. Trunk Lid (Cont'd)

3-3 TRUNK LID OPENER AND FUEL LID OPENER REMOVAL AND INSTALLATION

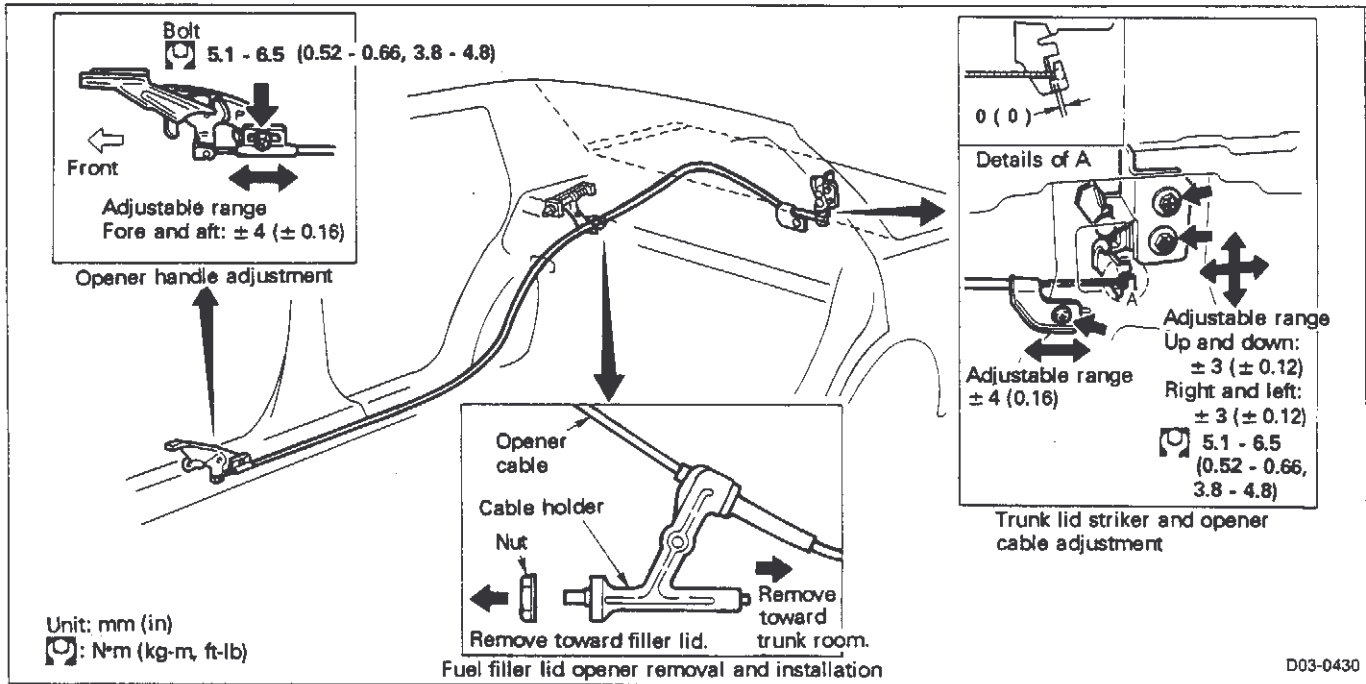

D4 BODY INTERIOR

1. Instrument Panel

1-1 INSTRUMENT PANEL ASSEMBLY REMOVAL, INSTALLATION AND DISASSEMBLY

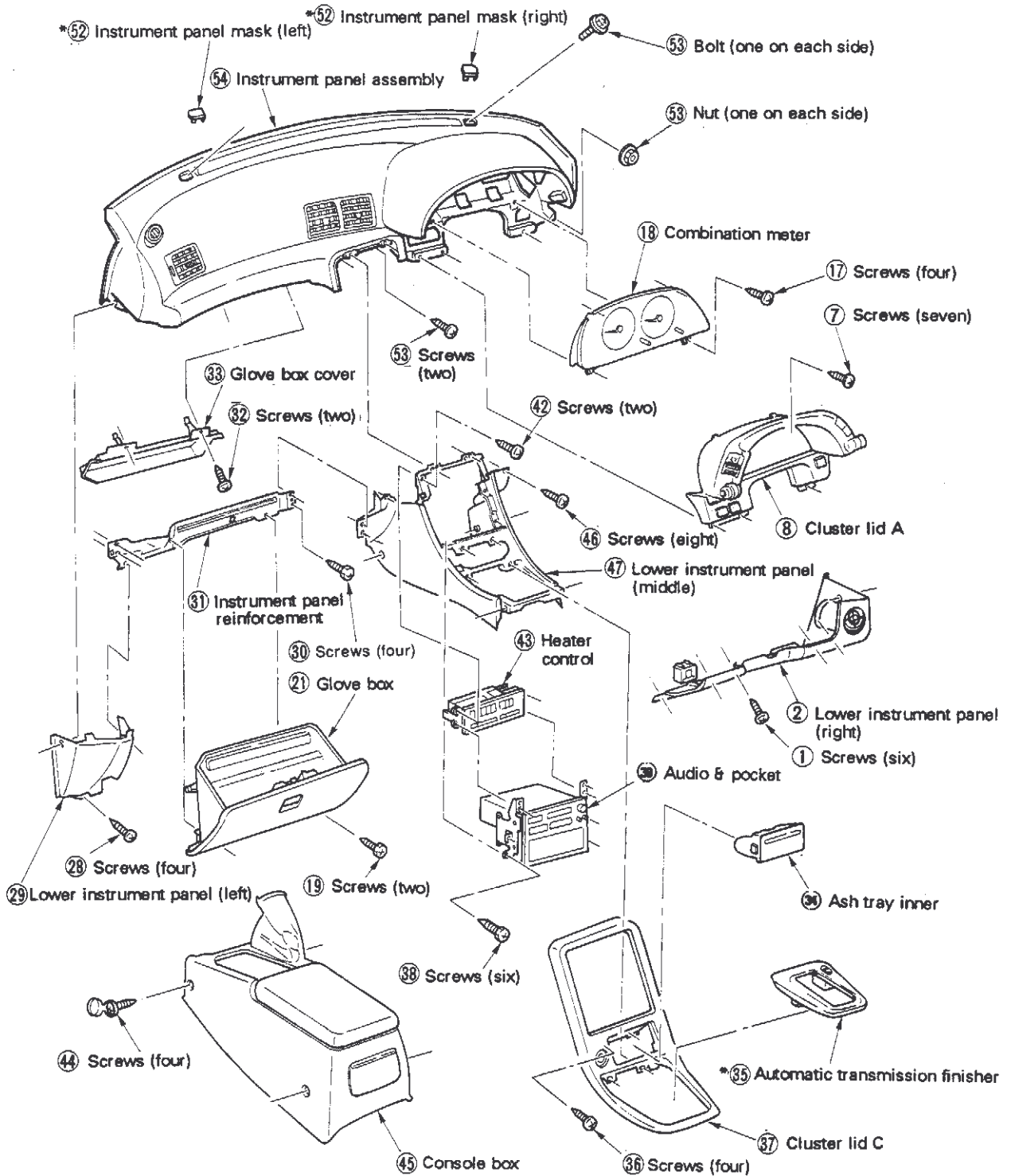

NOTE: Parts with mark * must be removed using screwdriver wrapped with vinyl tape or cloth.

D4 BODY INTERIOR

1. Instrument Panel (Cont'd)

1-2 ACCESSORY PARTS REMOVAL AND INSTALLATION AFTER REMOVING AND INSTALLING INSTRUMENT PANEL ASSEMBLY

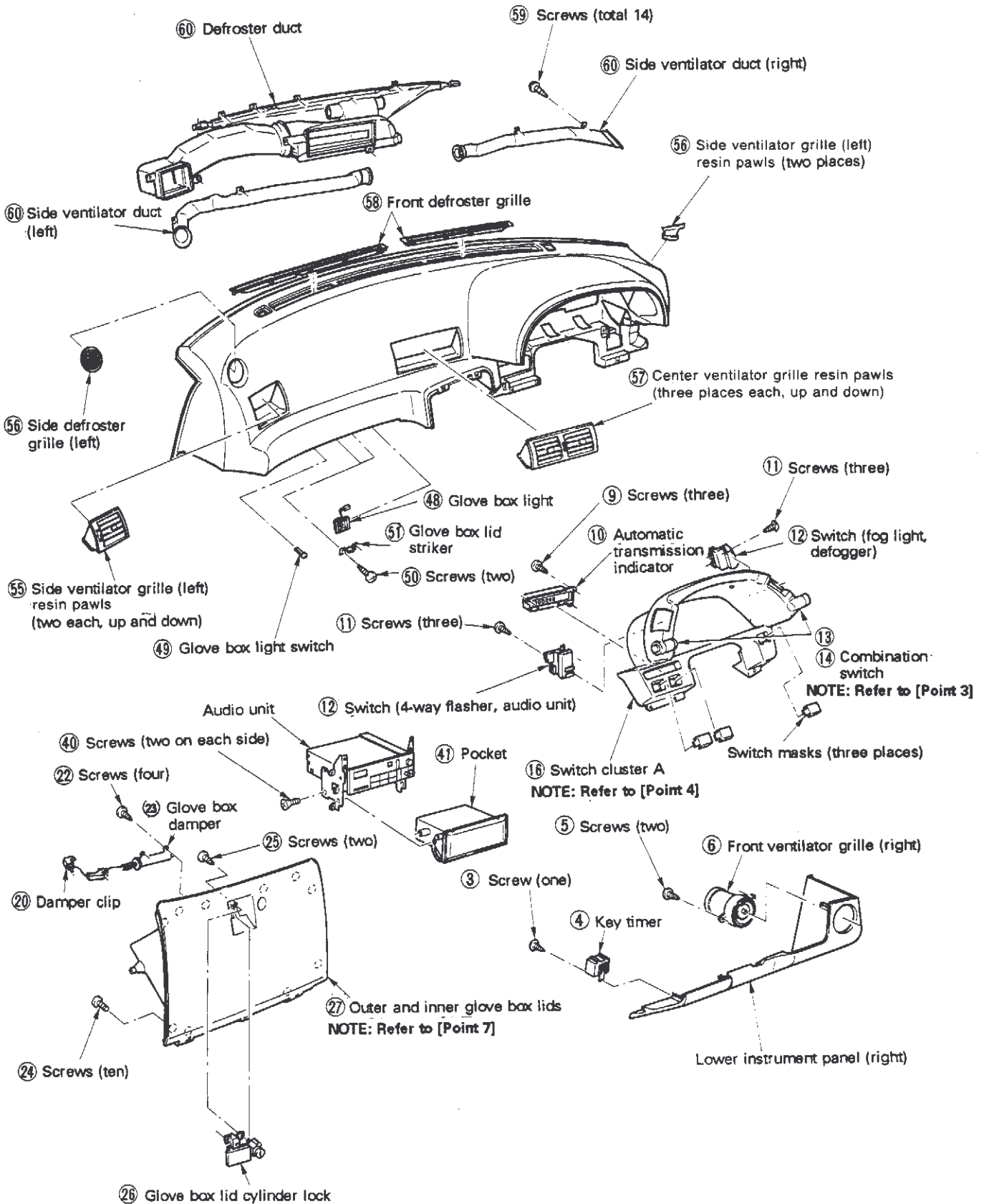

D4 BODY INTERIOR

1. Instrument Panel (Cont'd)

Detailed operations

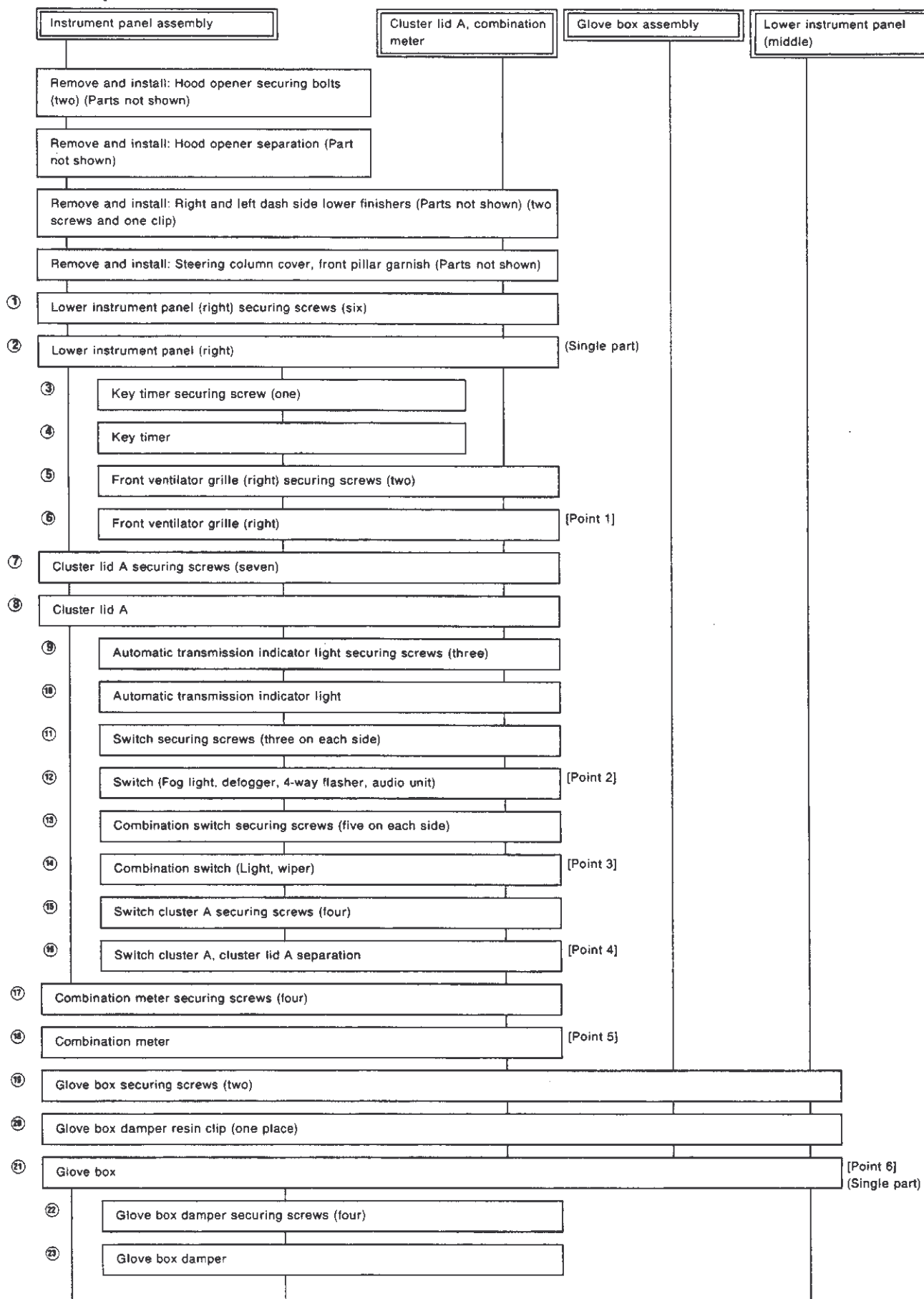

D4 BODY INTERIOR

1. Instrument Panel (Cont'd)

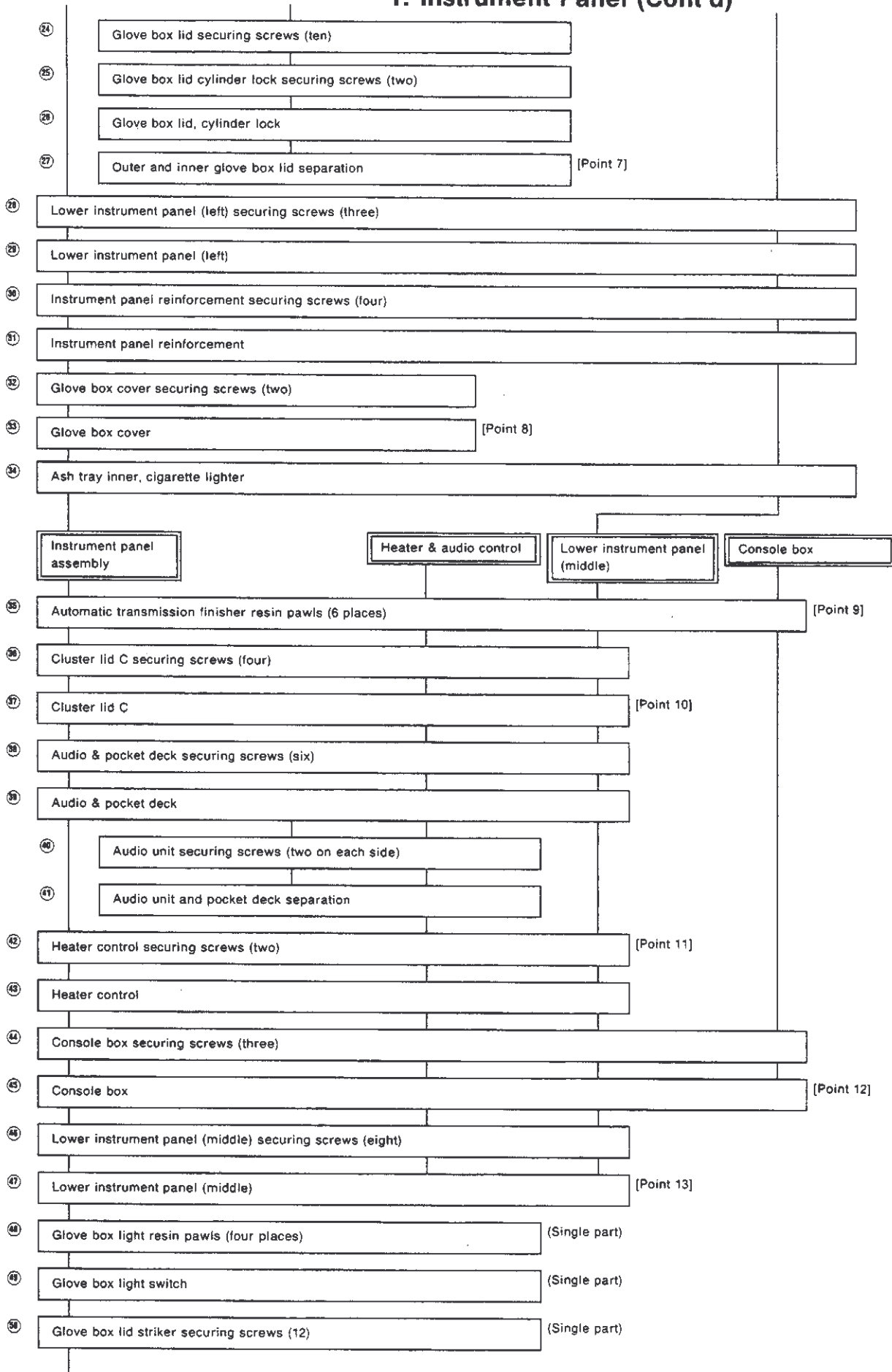

D4 BODY INTERIOR

1. Instrument Panel (Cont'd)

- 51)

Glove box lid striker

- 52)

Right and left instrument panel masks	[Point 14] (Single part)
---------------------------------------	--------------------------
- 53)

Instrument panel assembly securing bolts (two), screws (two), and nuts (two)
--
- 54)

Instrument panel assembly	[Point 15]
---------------------------	------------
- 55)

Side ventilator grille (left)	(Single part)
-------------------------------	---------------
- 56)

Side defroster grilles (right, left)	(Single part)
--------------------------------------	---------------
- 57)

Center ventilator grille	[Point 16] (Single part)
--------------------------	--------------------------
- 58)

Front defroster grille (right, left)

- 59)

Heater duct and nozzle securing screws (14)

- 60)

Heater duct and nozzle

D4 BODY INTERIOR

1. Instrument Panel (Cont'd)

[Point 1] Side ventilator grille (right) removal

Remove and install: Lower instrument panel cover, hood opener

- Remove ventilator grille securing screws (two) from rear side of lower instrument cover, and remove ventilator grille (right).

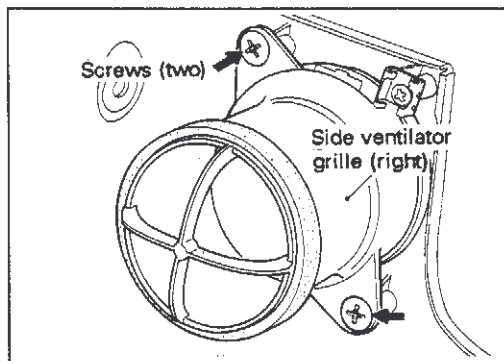

[Point 2] Cluster switch A removal

- Remove cluster lid A, and then remove screws (two on each side) from rear side, and separate cluster lid A and cluster switch A.

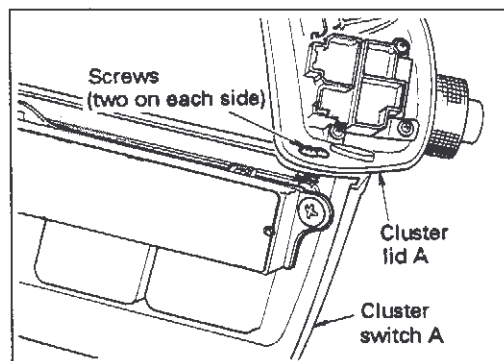

[Point 3] Control switch removal

- Remove control switch securing screws from rear side of cluster lid A, and then remove switch while pressing it inward.

NOTE:

When installing switch, pay attention not to tighten screws excessively.

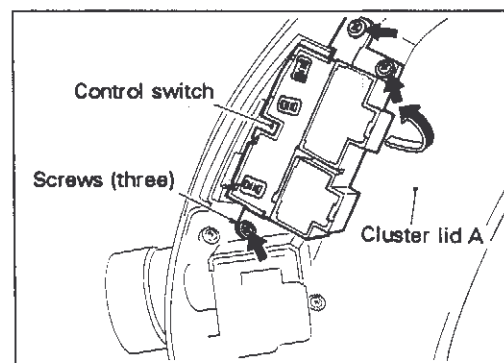

[Point 4] Combination switch removal and installation

Removal

- Remove switch knob by pulling in direction of arrow, and remove combination switch by removing securing screws (five) from rear side of cluster lid A.

NOTE:

Control switch must be removed before removing combination switch. (This precaution applies to both right and left sides.)

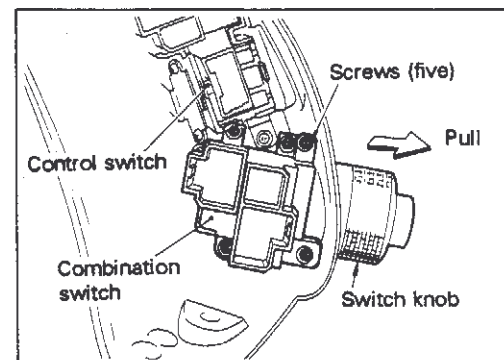

Installation

- Install switch, and then install switch knob by aligning mark position.
- After installation, check for normal switch operation by operating switch.

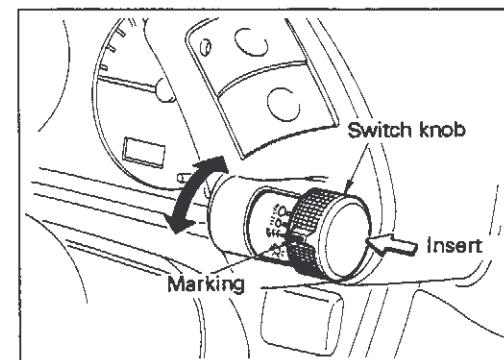

D4 BODY INTERIOR

1. Instrument Panel (Cont'd)

[Point 5] Combination meter removal

Remove and install: Cluster lid A (Parts not shown)

- Remove screws (four), and pull out combination meter.

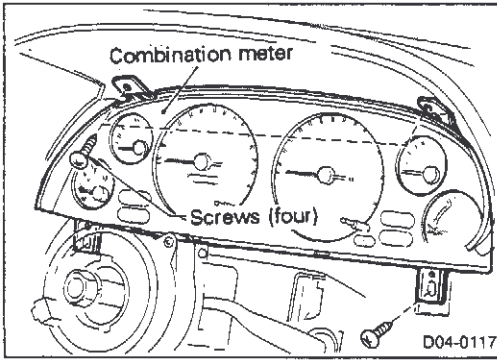

[Point 6] Glove box removal and installation

Removal

- Remove screws (two), and remove damper clip from bracket located inside of glove box.

Installation

- Insert clip into bracket while pulling damper wire, then install glove box fully closed.

NOTE:

Pay attention not to cut off damper wire.

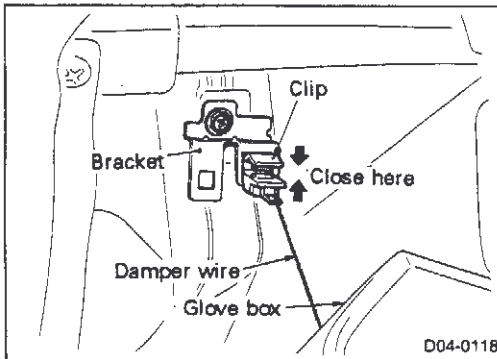

[Point 7] Glove box lid separation

- Remove lid securing screws (eight), and pull off lid hinge pin to disengage hinge, and then remove lower screws (two) to separate glove box lid into inner and outer portions.

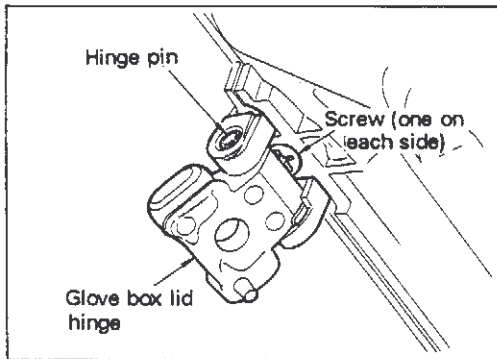

[Point 8] Glove box cover installation

- Install glove box light harness connector to cover, and fit cover clamp securely into steering member, and tighten screws (two).

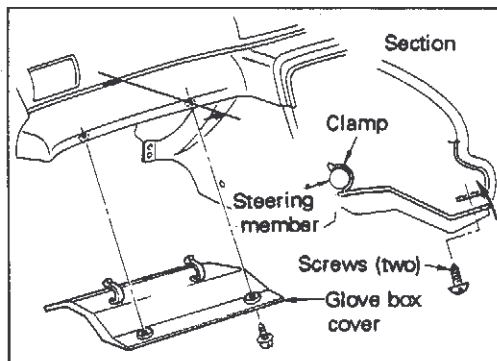

[Point 9] Cluster lid C removal and installation

Removal

- Remove cluster lid securing screws (four), and remove rear end metal clip using standard screwdriver, then remove cluster lid by pulling resin pawls fitted upper end portion forward.

Installation

- Fit resin pawls into respective position, and install cluster lid by pressing it in direction of arrow.

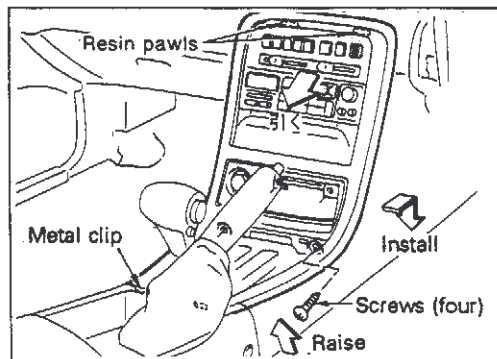

D4 BODY INTERIOR

1. Instrument Panel (Cont'd)

[Point 10] Heater control removal

- After removing audio unit, remove heater control securing screws (two) and remove heater control by pulling it to the side.

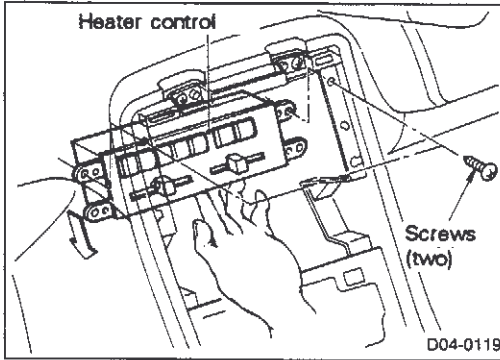

[Point 11] Console box removal and installation

Removal

- Remove console box securing screws (two on each side), and then remove console box by disengaging parking brake lever while lifting console box.

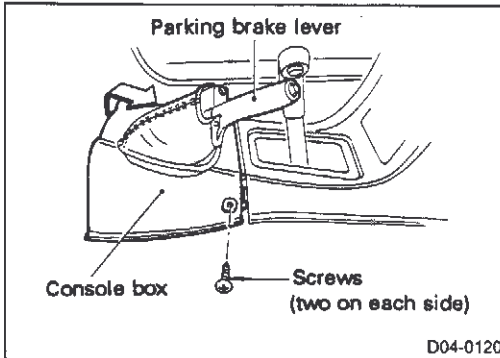

Installation

- Install console box by inserting resin pawls securely into respective holes of lower instrument panel.

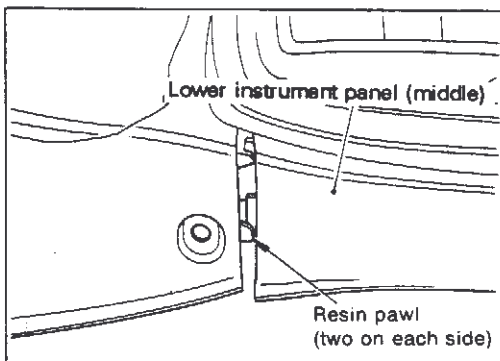

[Point 12] Lower instrument panel (middle) removal

- To prevent interference with parking brake lever, remove parking brake lever securing bolts (four) first, then remove lower instrument panel (middle) by pulling it rearward.

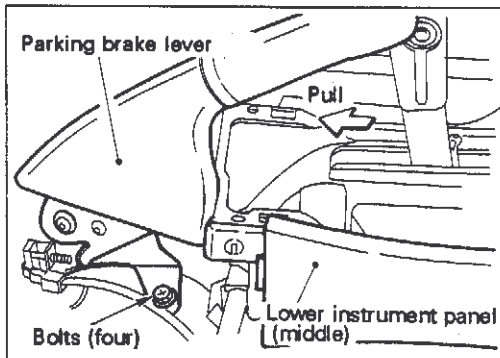

[Point 13] Instrument panel mask removal

- Remove instrument panel mask by inserting stubby standard screwdriver between mask and instrument panel pad.

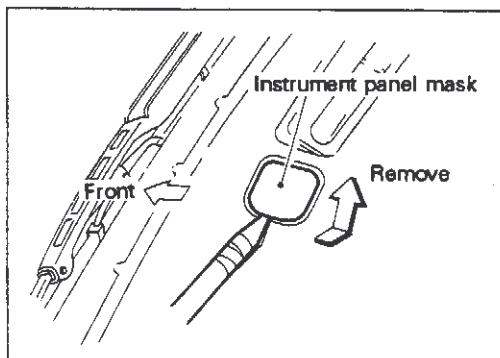

D4 BODY INTERIOR

1. Instrument Panel (Cont'd)

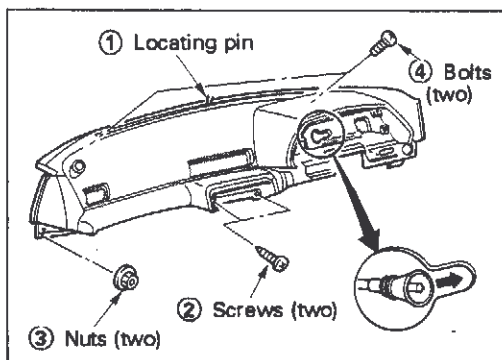

[Point 14] Instrument panel installation

- Set instrument panel by aligning locating pin, and then tighten screws in sequence shown at left.
- Make sure each duct is fitted correctly to grille.
- Secure speedometer cable by sliding it into cut-out portion of cable hole in instrument panel.

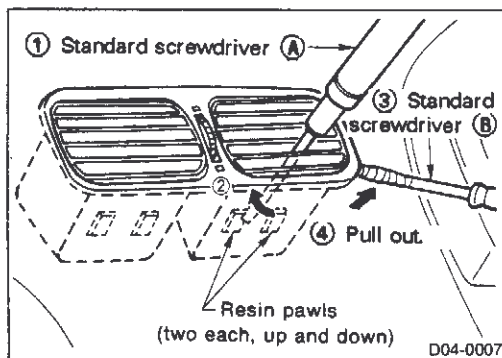

[Point 15] Ventilator grille removal

- ① Insert thin standard screwdriver **A** through clearance between grille fins.
- ② Pry up resin pawls by inserted screwdriver.
- ③ Insert another standard screwdriver **B** into clearance between grille and instrument panel.
- ④ Carefully pull out grille using screwdriver **B** while prying up resin pawls using screwdriver **A**, and remove grille from instrument panel assembly.

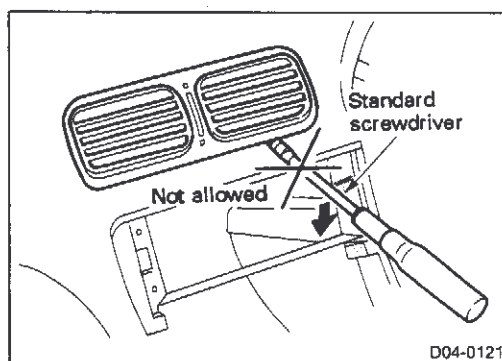

Notes on removal

- Because the grille pawls are positioned deep, do not attempt to pry up grille as shown at left; otherwise, grille main body and grille cover will be damaged.
- If unable to remove grille using method shown in steps ① thru ④, first remove instrument panel assembly, then remove ventilator grille.

D4 BODY INTERIOR

2. Interior Trim and Equipment (Cont'd)

(2) 2-door Sports Coupe

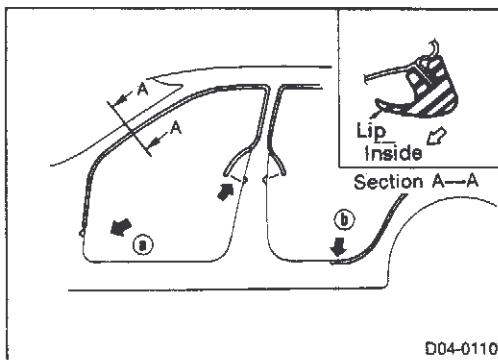
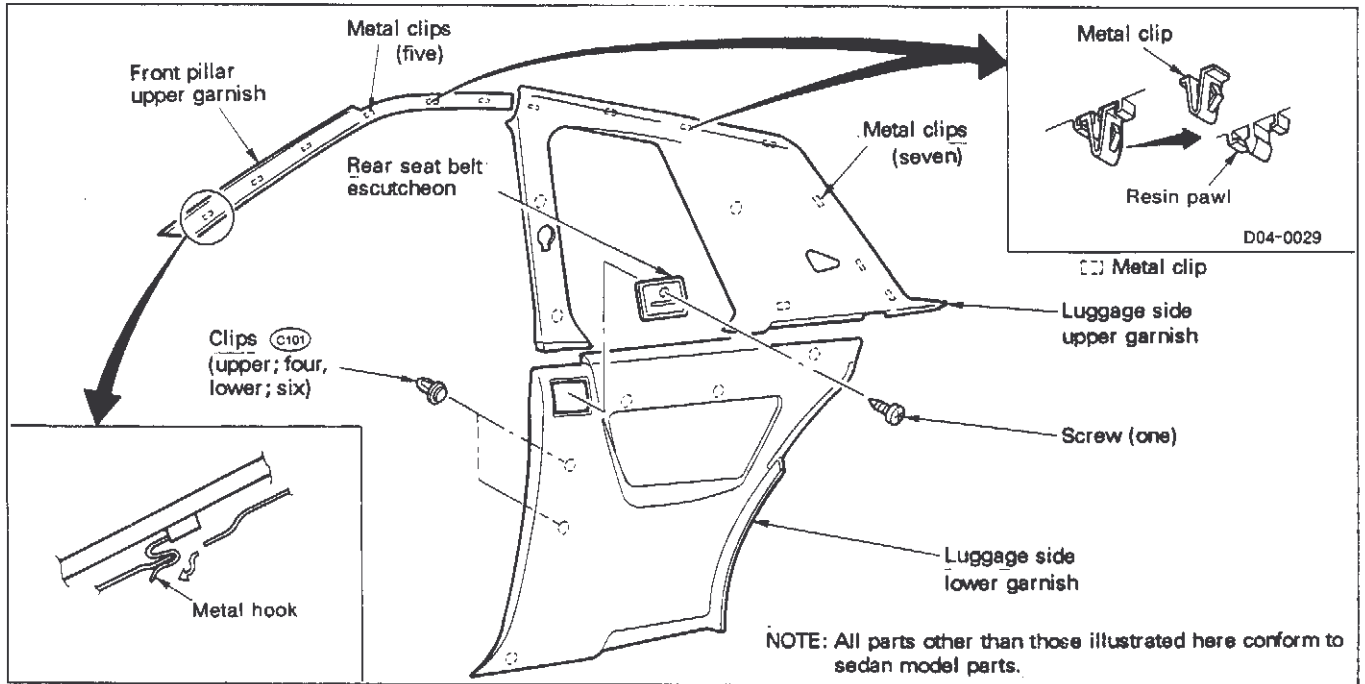

[Point 1] Body side welt installation

- Install body side welt by aligning welt end with cut-out notch of outer panel indicated by arrows at left so that lip will face inside of compartment.

NOTE:

2-door Coupe has notches at (a) and (b) only. (See illustration at left.)

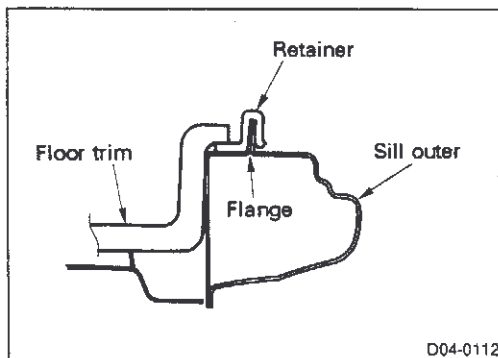

[Point 2] Retainer installation

- Fit floor trim retainer onto sill flange completely.

D4 BODY INTERIOR

2. Interior Trim and Equipment (Cont'd)

2-2 HEAD LINING REMOVAL AND INSTALLATION

(1) Standard model

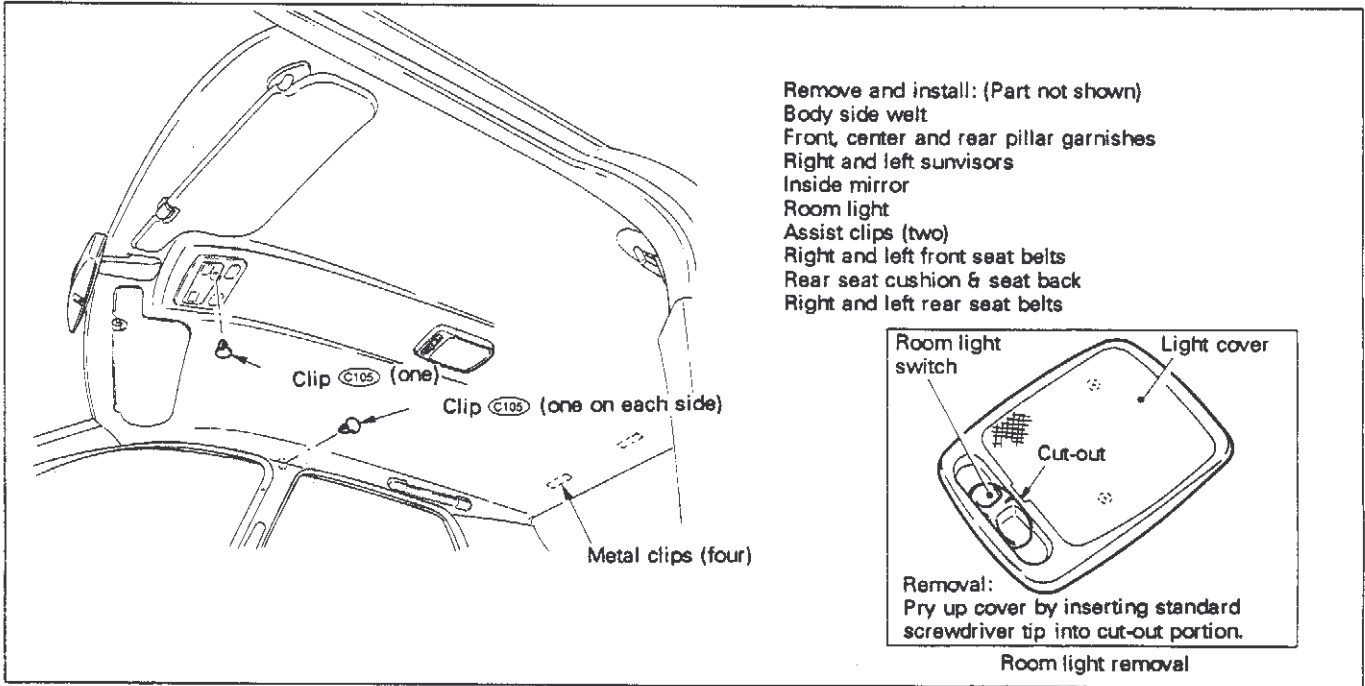

2-3 CONSOLE BOX REMOVAL AND INSTALLATION

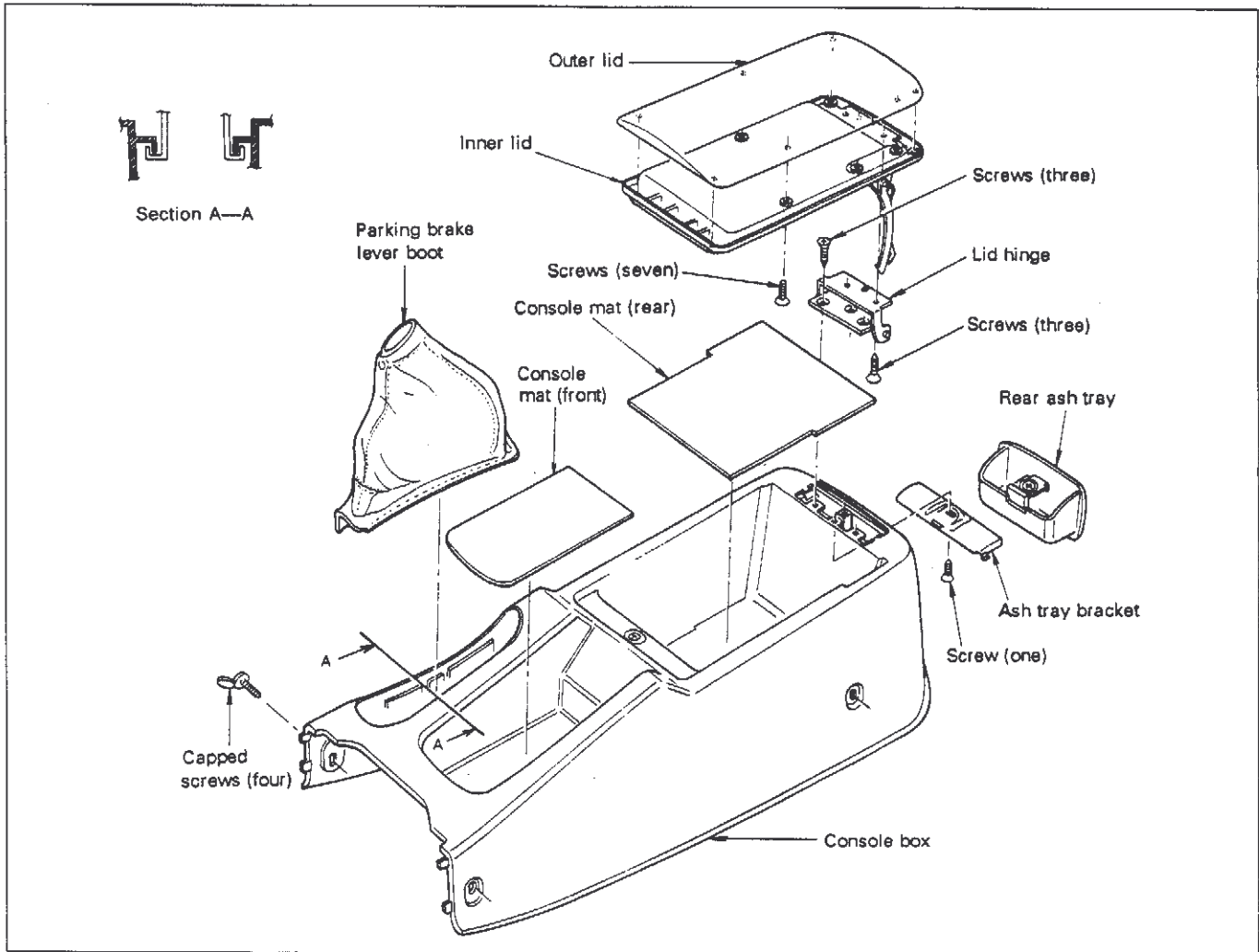

D4 BODY INTERIOR

2. Interior Trim and Equipment (Cont'd)

[Point 1] Capped screw removal

- Open screw head cap using standard screwdriver, and then remove screw.

NOTE:

Cap is made integral with screw. Pay attention not to tear off cap from base.

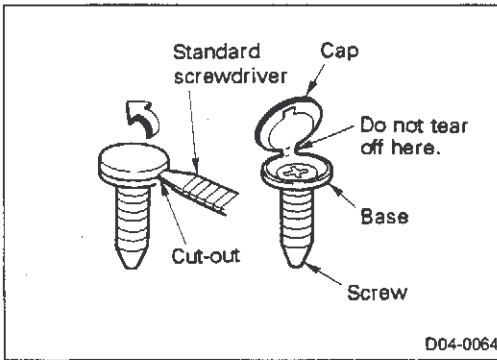

2-4 TRUNK TRIM REMOVAL AND INSTALLATION

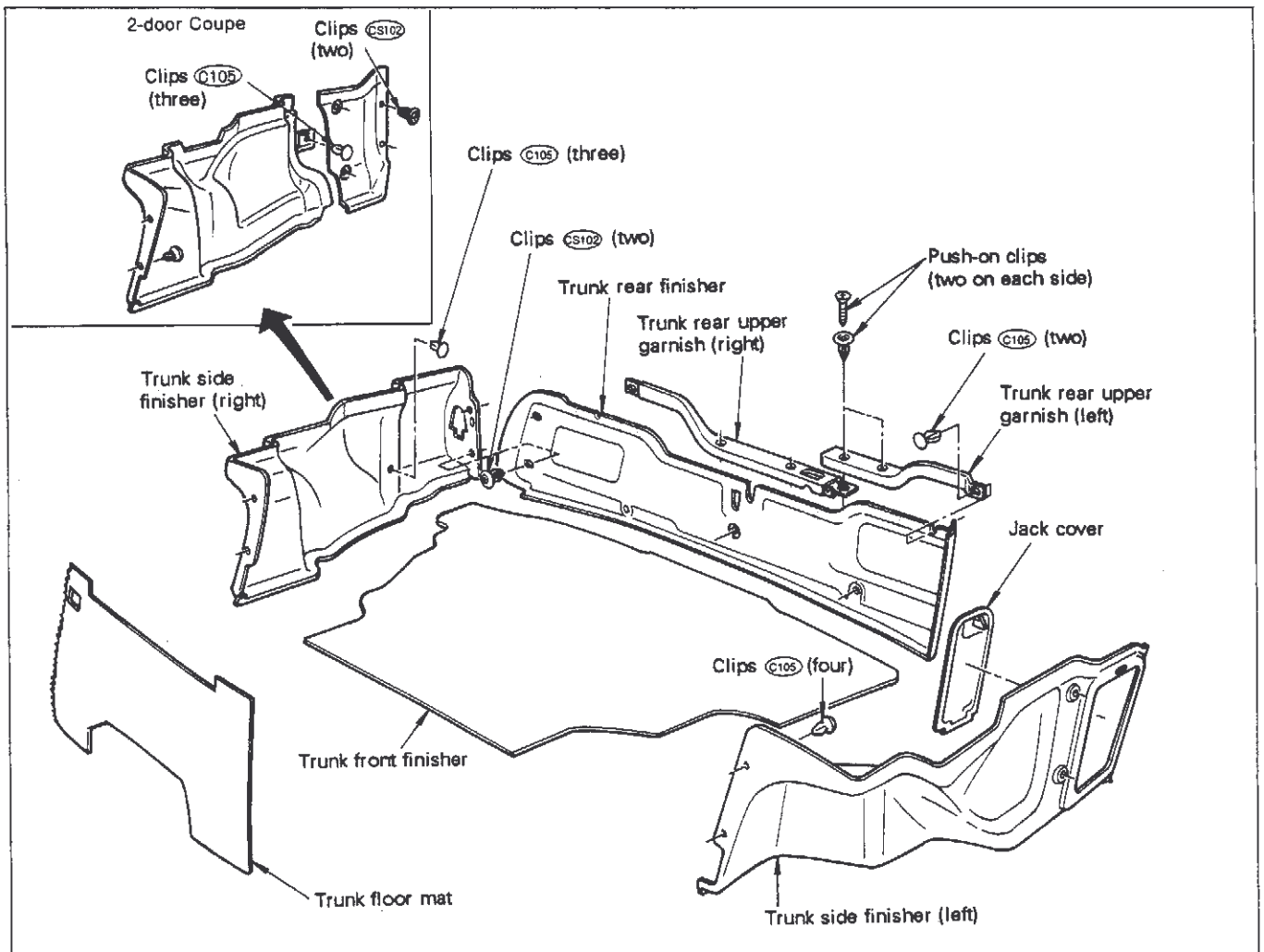

D4 BODY INTERIOR

3. Seat (GT-R model)

3-1 FRONT SEAT REMOVAL & INSTALLATION, AND DISASSEMBLY

Disassembly

Removal and installation

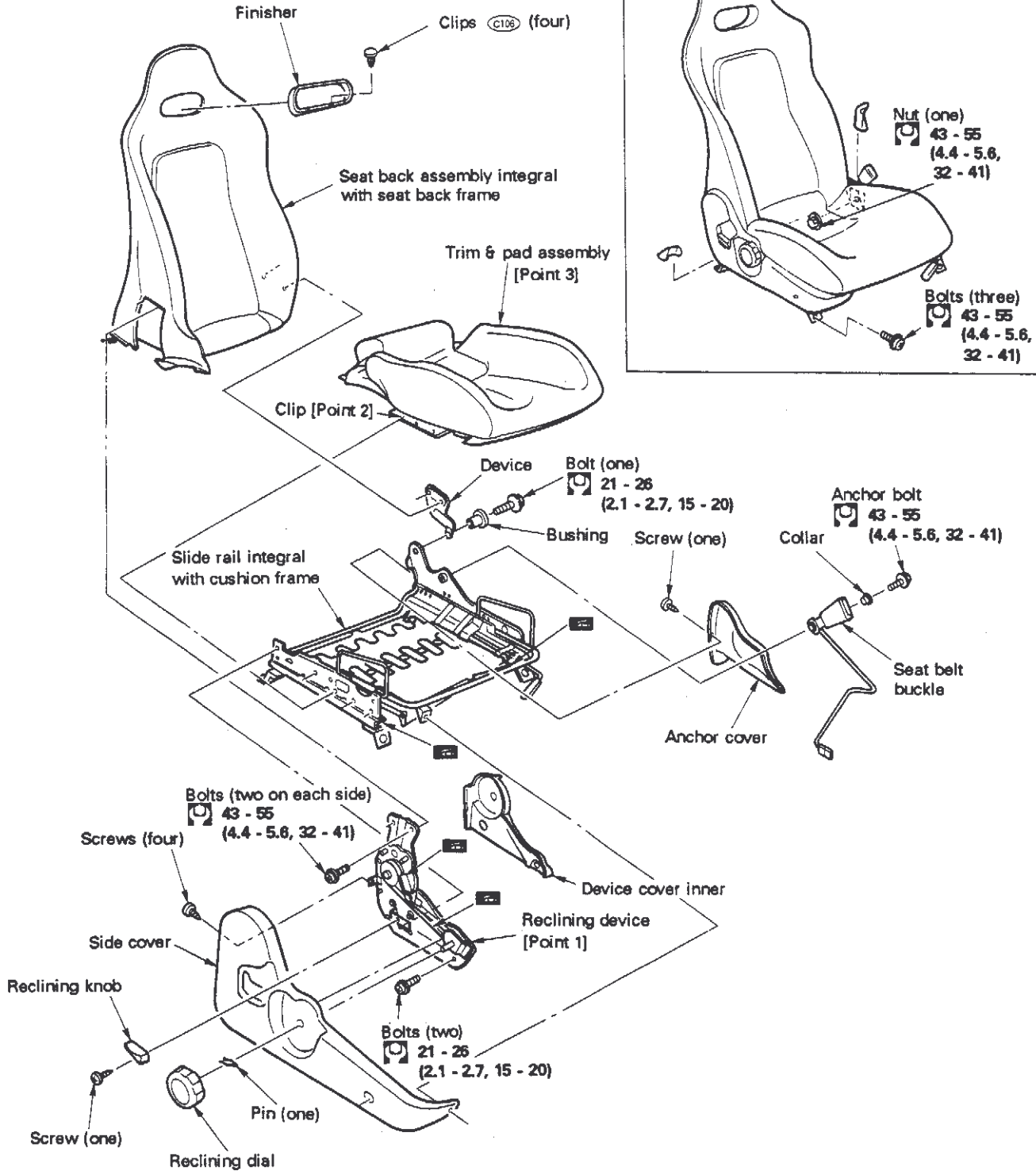

: N·m (kg·m, ft·lb)

: Nissan MP special grease No. 2

D4 BODY INTERIOR

3. Seat (GT-R model) (Cont'd)

[Point 1] Reclining device removal

- Remove trim end fastener of seat back assembly, and remove two securing bolts by taking off trim.

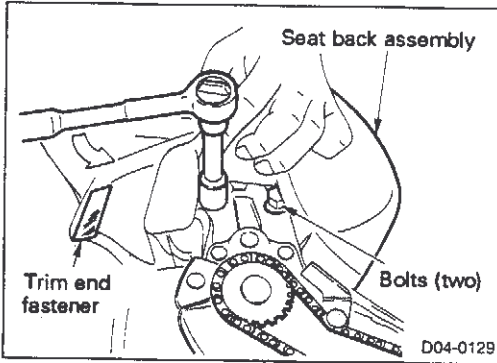

[Point 2] Seat trim clip removal (outer side)

- Using clip screwdriver, carefully remove three clips which secure seat trim to slide rail on side face of seat cushion.

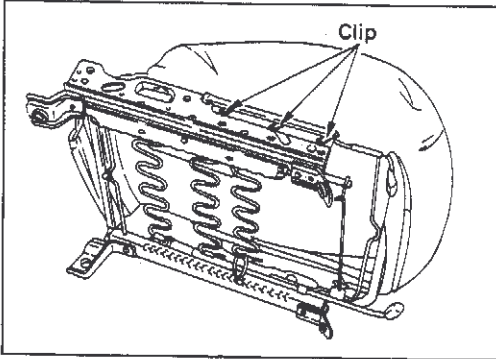

[Point 3] Seat trim retainer removal and installation (inner side)

Removal

- Disengage seat trim retainer from seat frame by pushing down with finger.

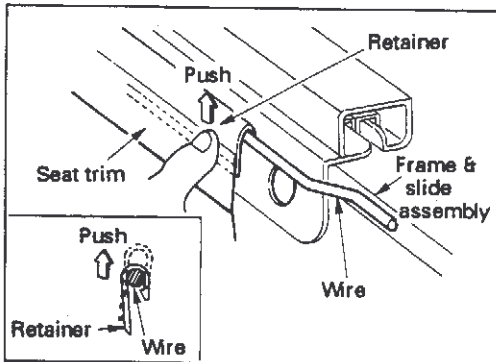

Installation

- Hook trim & pad assembly to seat frame, and inner side retainer to wire.
- Install trim & pad assembly while making sure trim and retainer are correctly engaged.

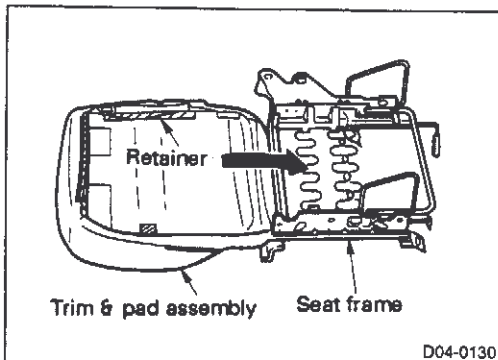

D4 BODY INTERIOR

3. Seat (GT-R model) (Cont'd)

3-2 REAR SEAT REMOVAL & INSTALLATION, AND DISASSEMBLY

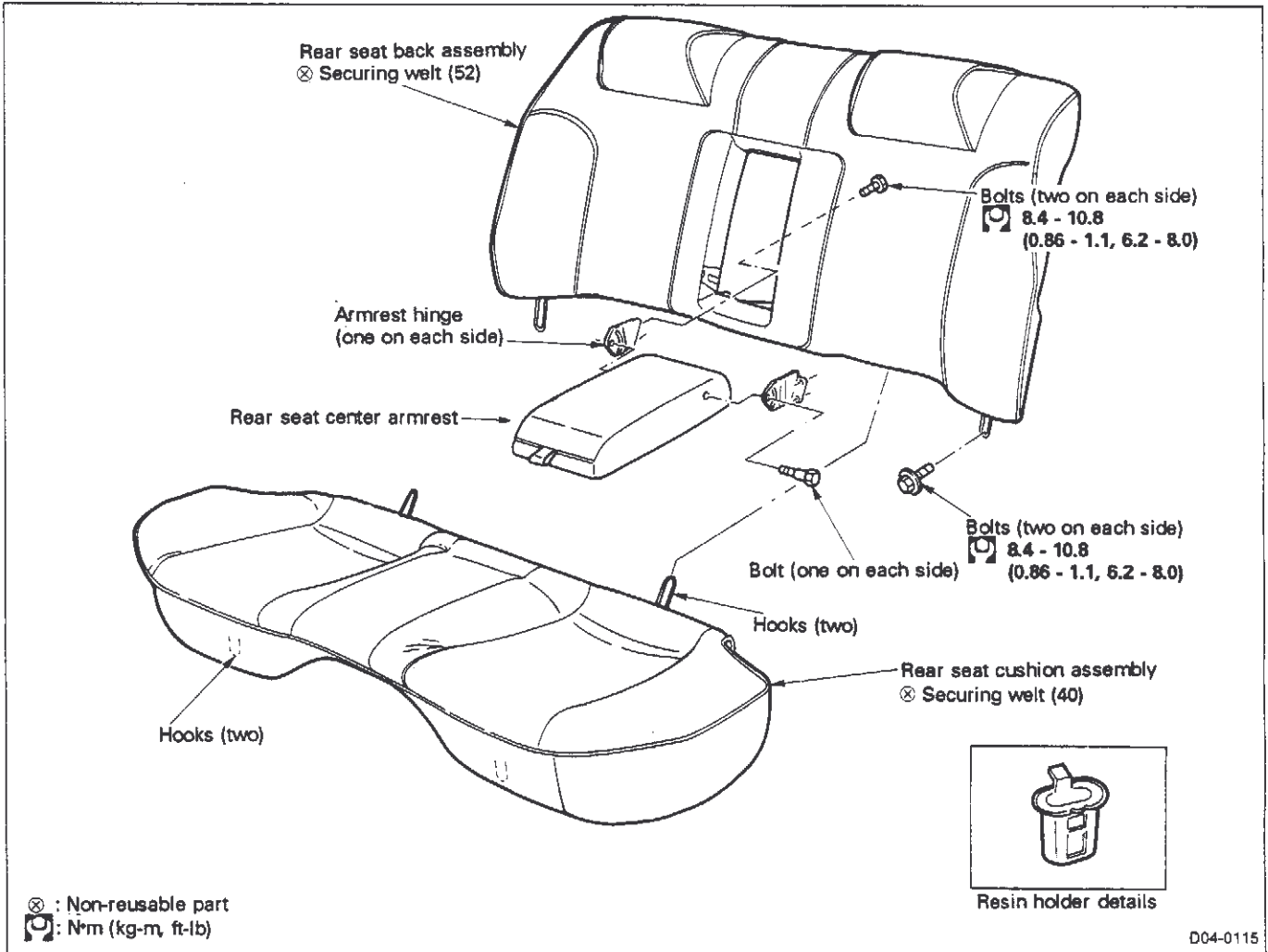

D4 BODY INTERIOR

4. Seat Belts

4-1 SEAT BELT ANCHORAGE

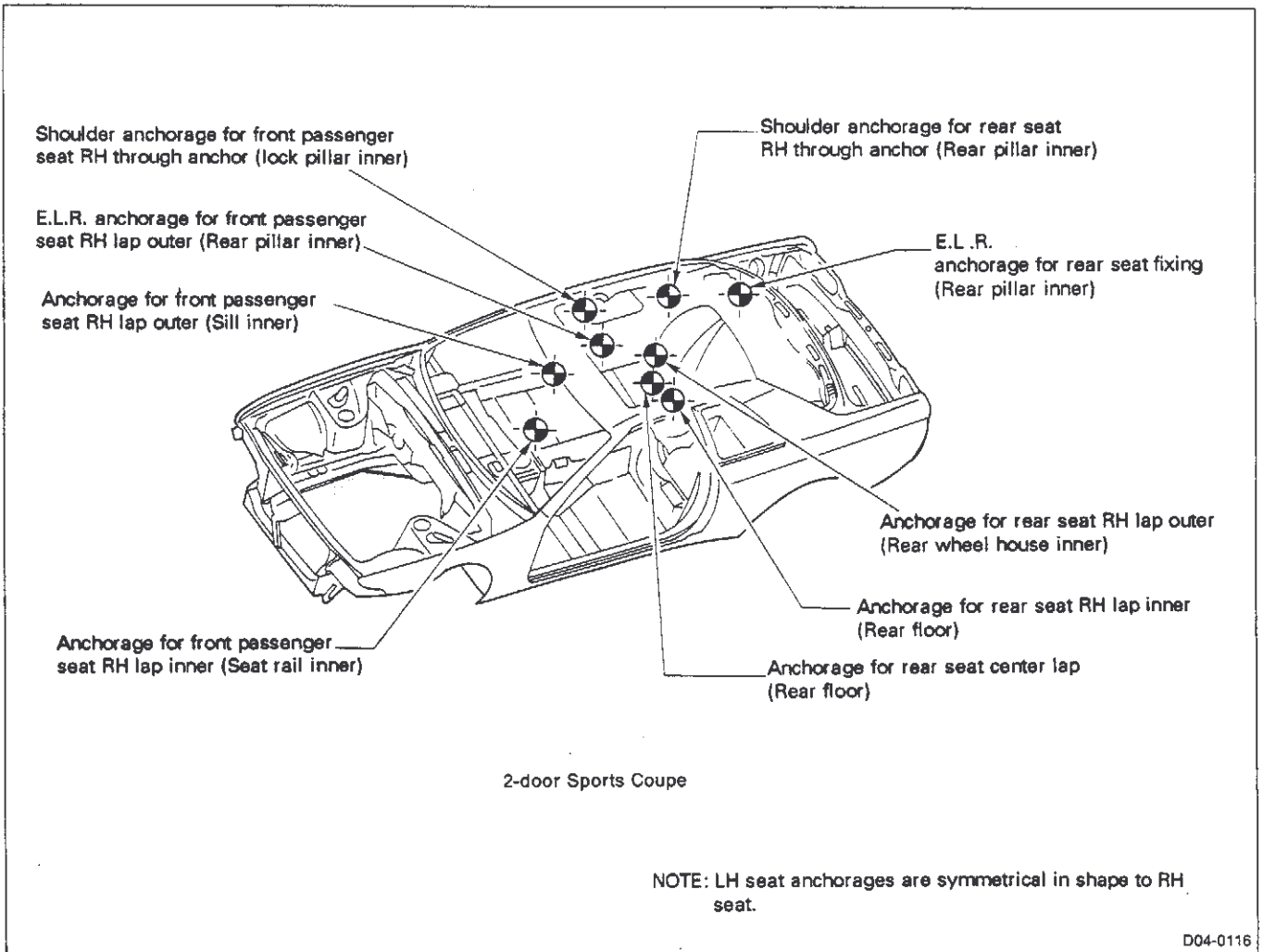

D04-0116

D4 BODY INTERIOR

4. Seat Belts (Cont'd)

4-2 FRONT SEAT BELT REMOVAL AND INSTALLATION

2-door Sports Coupe

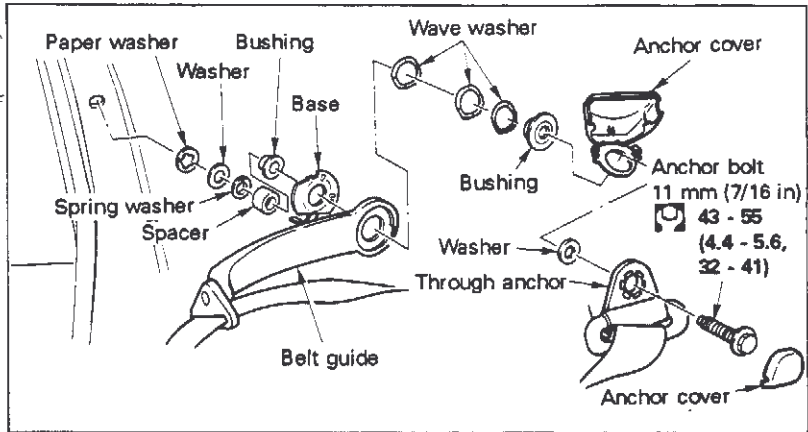
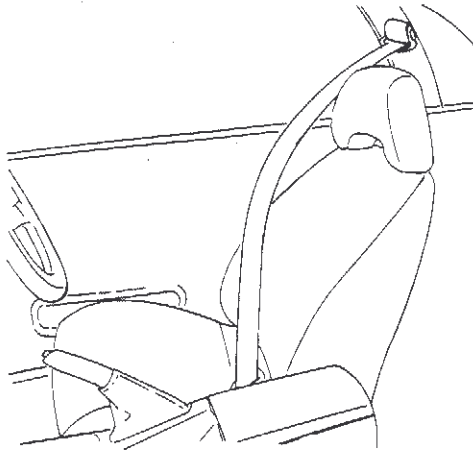

Shoulder anchor section

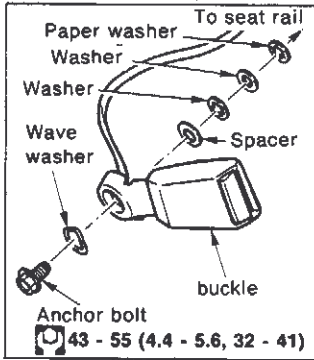

R.H. lap inner section

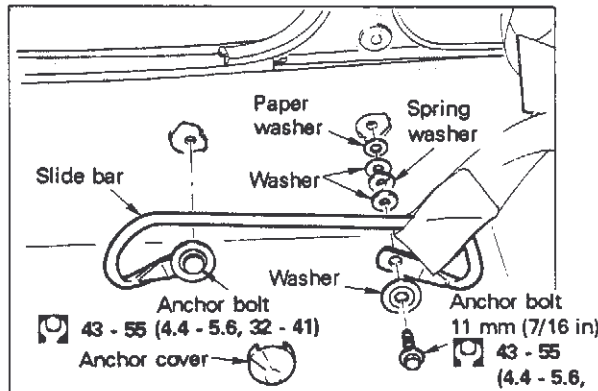

RH lap outer section

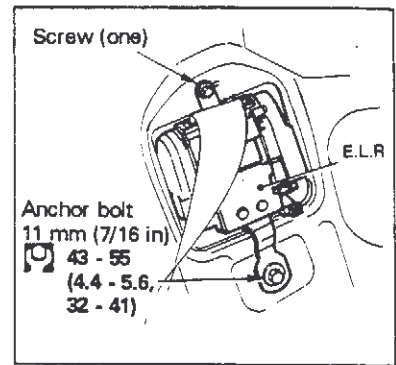

E.L.R. section

: N·m (kg-m, ft-lb)

D04-0123

D4 BODY INTERIOR

4. Seat Belts (Cont'd)

4-3 REAR SEAT BELT REMOVAL AND INSTALLATION

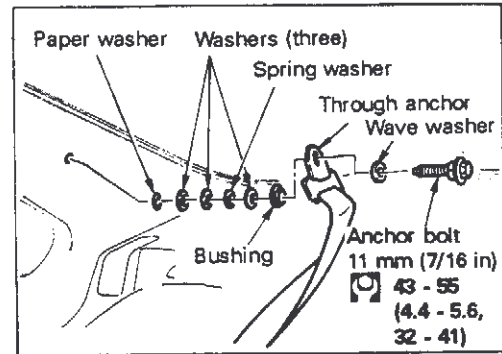
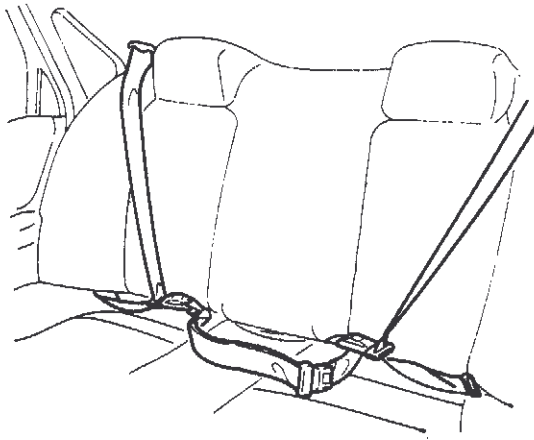

Shoulder anchor section

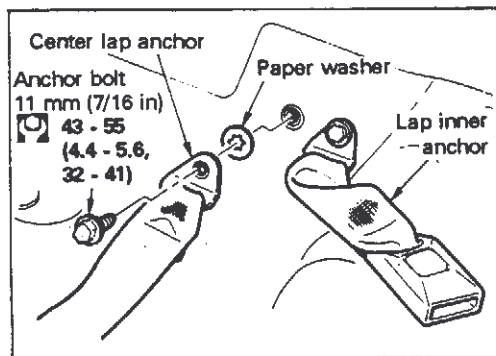

Floor section

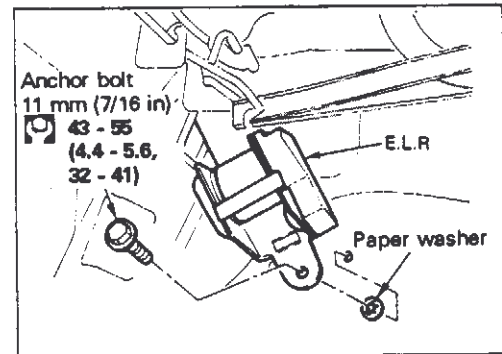

E.L.R. section

 : N·m (kg·m, ft·lb)

D04-0108

Inspection

- Check whether seat belt can be handled normally.
- Check seat belt webbing for damage, wear, discoloration, and metal parts for deformation.

NOTES:

- (1) Use neutral detergent to clean webbing.
- (2) Do not disassemble belt buckle and E.L.R. assembly.

HEATER & AIR CONDITIONER

SECTION **HA**

CONTENTS

H HEATER & AIR CONDITIONER	
H1 AIR CONDITIONER	HA- 2
1. Full Automatic Air Conditioner	HA- 2
1-1 Prior to trouble diagnosis	HA- 2
1-2 System diagram	HA- 3
1-3 Self-diagnosis	HA- 4
1-4 Sensor inspection	HA-10
1-5 Actuator inspection	HA-15
1-6 Actuator removal and installation	HA-23

H1 AIR CONDITIONER

1. Full Automatic Air Conditioner

1-1 PRIOR TO TROUBLE DIAGNOSIS

This fully automatic air conditioner has a self-diagnostic function for checking its major components. Using this self-diagnostic function, it is possible to check whether the signal issued from each sensor is within the effective range of the respective sensor characteristics, and whether each actuator can respond correctly to a control signal issued by force under a predetermined condition. It is also possible to check the function of the display section, mode signal, and each sensor. This means that, using the self-diagnostic function, most components of this fully automatic air conditioner can be checked. After identifying a faulty section, however, each sensor or actuator must be examined using conventional method.

If an error in the electrical system is determined as the cause of a fault, for example, it is also necessary to check fuses, connectors, and terminals, etc. in addition to self-diagnosis.

Fuses that need inspection

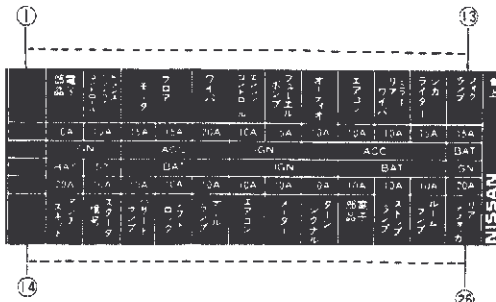

No.	Capacity	Power supply system	Major load (Air conditioner)
4	15A	ACC	Blower fan motor, auto amplifier
5			
10	10A	IGN	Magnet clutch
20			Air conditioner relay, intake door actuator, HI relay, auto amplifier
23		BAT	Auto amplifier

The basic troubleshooting flow diagram is shown below:

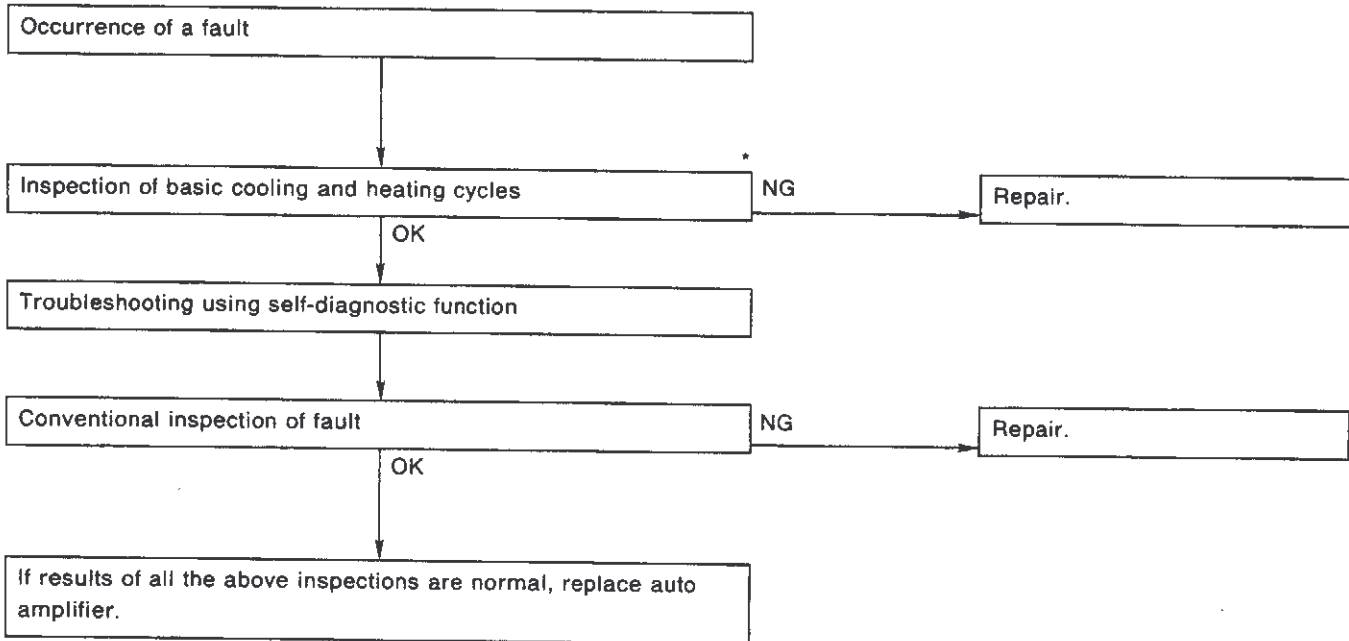

(*) NOTE:

Self-diagnostic function is unable to check such phenomena that cannot be reproduced.

H1 AIR CONDITIONER

1. Full Automatic Air Conditioner (Cont'd)

1-2 SYSTEM DIAGRAM

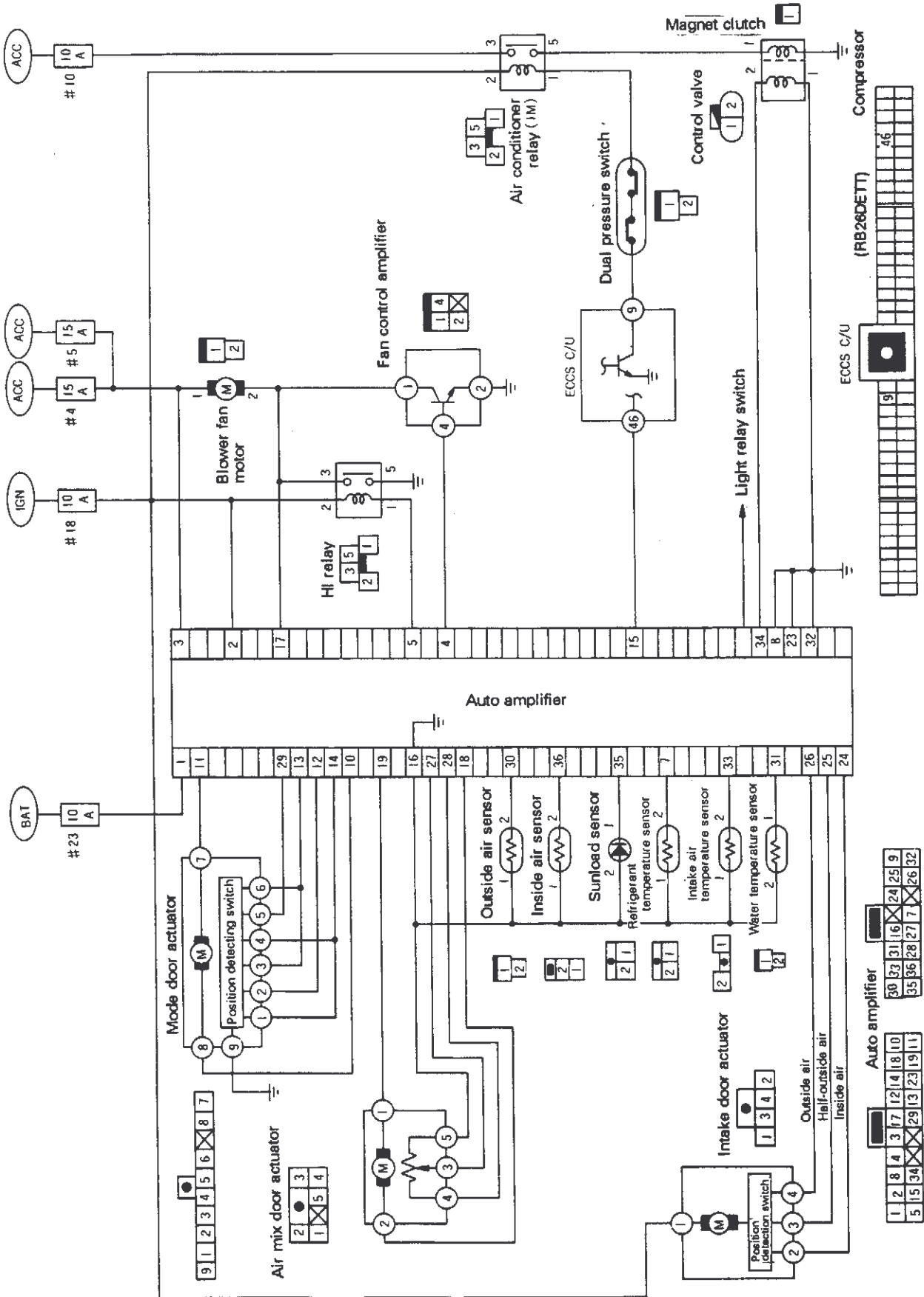

H1 AIR CONDITIONER

1. Full Automatic Air Conditioner (Cont'd)

1-3 SELF-DIAGNOSIS

(1) Self-diagnosis set

To change from ordinary automatic air conditioner control mode into self-diagnosis mode, depress automatic air conditioner OFF switch for more than five seconds within 10 seconds after turning ignition switch to ON from OFF. Start engine to prevent discharging discharged battery when performing self-diagnosis.

To return to automatic air conditioner control mode from self-diagnostic mode, turn ignition switch OFF, or depress air conditioner switch.

Self-diagnostic program is designed to facilitate detection of a fault. It consists of the following five self-diagnostic steps and one customizing step.

Steps 1-5 can be selected by depressing HOT switch or COLD switch. Steps 5 and 6 can be selected by depressing fan switch.

NOTE:

Step 6 is not used for trouble diagnosis.

Description of each step

Step 1:	Segment check (Display section and LED)
Step 2:	Sensor check
Step 3:	Mode door position check
Step 4:	Actuator operation check
Step 5:	Sensor recognition temperature display
Step 6:	<ul style="list-style-type: none"> ● To set difference between display temperature and sensed temperature ● To memorize intake port when ignition switch is OFF

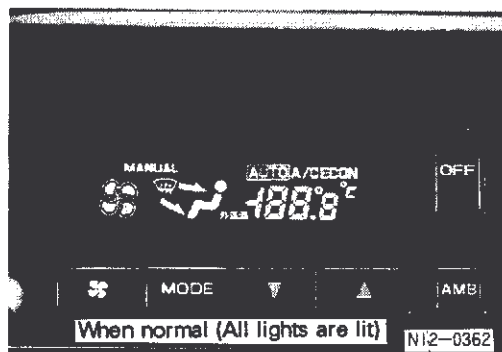

(2) Step 1 (Display section and LED segment check)

Normal: All display and LEDs are lit.

Abnormal: Failed portion is not lit.

H1 AIR CONDITIONER

1. Full Automatic Air Conditioner (Cont'd)

(3) Step 2 (Sensor check)

Step 2 is selected by depressing HOT switch(Δ)while in step 1 status.

Microcomputer detects whether each sensor input signal satisfies set conditions, and results are displayed on display section.

Normal: '20' is displayed in display section.

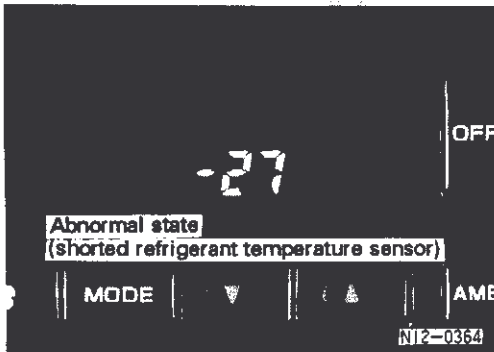

Abnormal: Failed sensor number is displayed. If sensor short-circuit is detected, a minus sign (-) is also indicated.

If error is detected in two or more sensors, each sensor number is displayed by flashing twice in turn.

NOTE:

If vehicle is positioned in dark place or if sunlight is exceptionally strong, then sunload sensor error may be indicated.

Display number and corresponding sensor, and judgment criteria

Display No.	Sensor	When disconnected	When shorted
20	(Normal)	—	—
21	Outside air sensor	Below -60°C (-76°F)	Above 100°C (212°F)
22	Inside air sensor	Below -60°C (-76°F)	Above 100°C (212°F)
23	Water temperature sensor	Below -50°C (-58°F)	Above 150°C (302°F)
24	Intake temperature sensor	Below -50°C (-58°F)	Above 100°C (212°F)
25	Sunload sensor	Below 0.030 kW (26 kcal/h, 103 BTU/h)/ m^2 [0.0028 kW (2.42 kcal/h, 9.6 BTU/ h)/sq ft]	Above 1.323 kW (1,138 kcal/h, 4,516 BTU/h)/ m^2 [0.1229 kW (105.72 kcal/h, 419.5 BTU/h)/ sq ft]
26	PBR (Note)	Above 4.9V	Below 0.1V
27	Refrigerant temperature sensor	Below -50°C (-58°F)	Above 100°C (212°F)

NOTE:

PBR is judged based on air mix door opening of 40%.

(Full cold: 0%, full hot: 100%)

If sensor is judged as faulty in step 2, check single sensor according to "1-4. SENSOR INSPECTION", and determine whether failure is in sensor or harness.

H1 AIR CONDITIONER

1. Full Automatic Air Conditioner (Cont'd)

(4) Step 3 (Mode door position check)

Depress HOT switch (Δ) while in step 2 status, and step 3 will be selected.

In this step, mode door actuator operates, and whether input signal from position detection switch is normal is checked by microcomputer, and the results are indicated on display section.

NOTE:

Approximately 16 seconds are required to complete inspection of all modes.

NORMAL: '30' will be displayed.

ABNORMAL: Number of faulty modes are displayed.

If two or more modes are faulty, each mode number is displayed by flashing twice in turn.

NOTE:

Connector disconnection is indicated by the following pattern: 31 \rightarrow 32 \rightarrow 34 \rightarrow 35 \rightarrow 36.

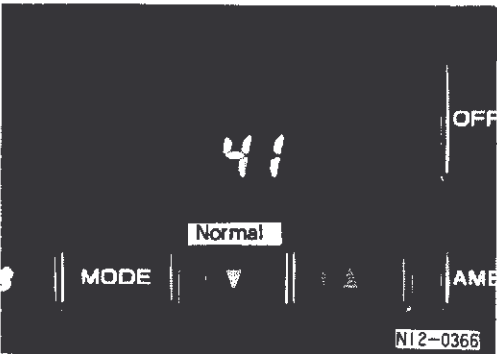
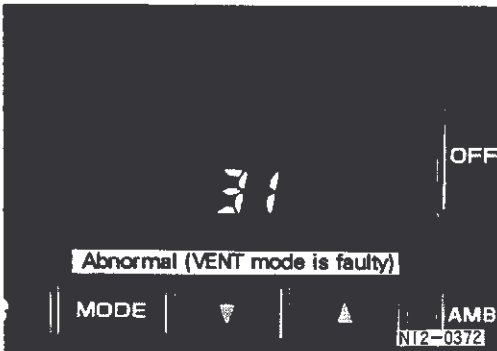
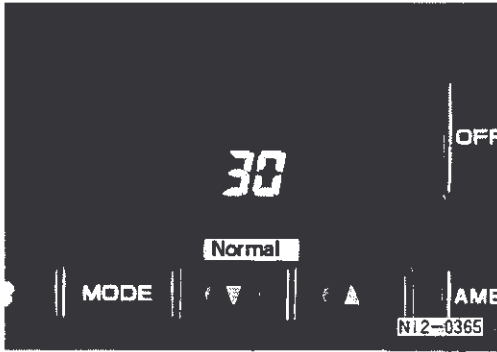

Display number and corresponding mode

Display No.	Mode	Display No.	Mode
30	(Normal)	34	FOOT
31	VENT	35	D/F
32	B/L	36	DEF

If any mode is judged as faulty in step 3, it indicates that harness or mode door actuator is faulty.

(5) Step 4 (Each actuator operation check)

If HOT switch (Δ) is depressed while in step 3, step 4 is selected, and '41' displayed. If AMB switch (**AMB**) is depressed in this status, displayed number will change to 42, 43, ... upon each depression of switch, and return to 41 after 47 is displayed.

Auto amplifier provides specified output to each actuator, blower motor and compressor corresponding to these displayed numbers. Check operation of these units visually, or by listening or feeling vibration.

H1 AIR CONDITIONER

1. Full Automatic Air Conditioner (Cont'd)

NOTE:

Output to compressor is provided as magnet clutch ON-OFF signal and control valve output signal. Control valve output signal causes compressor swash plate inclination angle to change to control compressor delivery. This can be checked by measuring auto amplifier output voltage using a circuit tester.

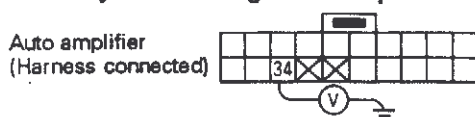

Display number and operation status

Display number	Intake door	Air mix door	Mode door	Blower motor	Compressor	
					Magnet clutch ON-OFF	Output voltage to control valve
41	Inside air	Full cold	VENT	5V	ON	Approx. 1V
42	Inside air	Full cold	VENT	5V	ON	Approx. 4.5V
43	Inside air	Full cold	B/L	10.5V	ON	Approx. 2.5V
44	Half-outside air	Full hot	B/L	8.5V	ON	Approx. 2.5V
45	Outside air	Full hot	FOOT	8.5V	ON	Approx. 4.5V
46	Outside air	Full hot	D/F	8.5V	OFF	0V
47	Outside air	Full hot	DEF	12V	ON	Approx. 2.5V

If abnormality of any portion is detected in step 4, be sure to perform inspection according to "1-5 ACTUATOR INSPECTION" flowchart.

Abnormal section	Flowchart
Intake door	1-5 (1) Intake door system
Air mix door	1-5 (2) Air mix door system
Blower motor	1-5 (3) Blower motor system
Compressor	1-5 (4) Compressor system

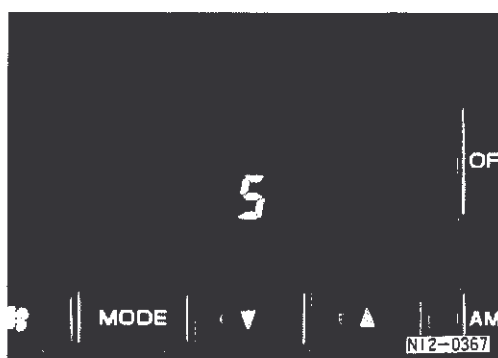

(6) Step 5 (Sensor recognition temperature indication)

If HOT switch (Δ) is depressed while in step 4, then step 5 is selected and '5' is indicated in display section. If AMB switch (**AMB**) is depressed in this status, temperatures sensed by outside air sensor, inside air sensor, suction temperature sensor and refrigerant temperature sensor are displayed in the following sequence.

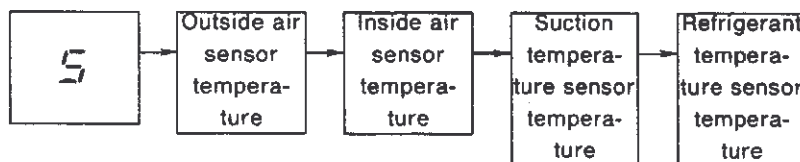

H1 AIR CONDITIONER

1. Full Automatic Air Conditioner (Cont'd)

If temperature displayed in step 5 is excessively different from actual temperature, check suspected sensor according to "1-4 SENSOR INSPECTION".

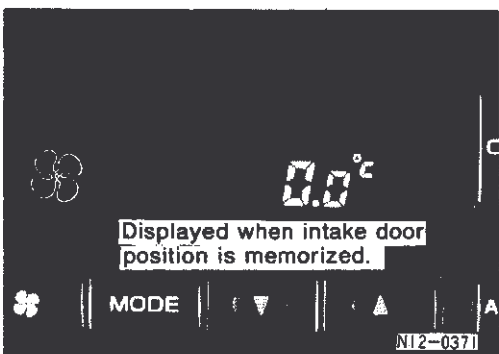
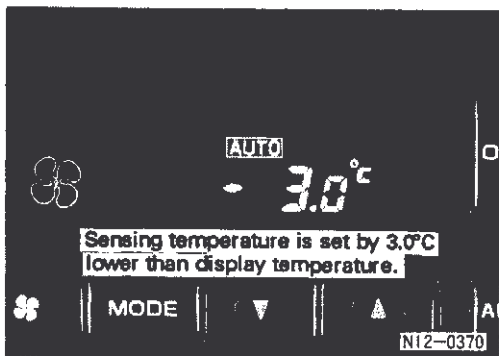
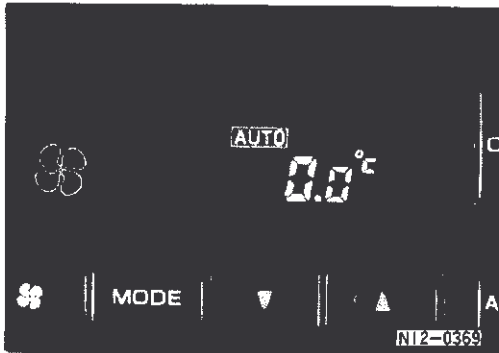
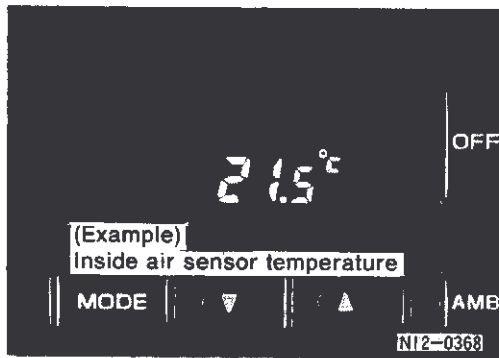

(7) Step 6 (Not used when troubleshooting)

Depress fan switch () while in step 5, then step 6 is selected and display appears as shown at left. If fan switch is depressed again, step 5 is selected again.

① Setting difference between indicated temperature and sensed temperature

- If passenger's bodily sensation differs from the temperature set on the display section, then the auto amplifier sensing temperature can be changed with respect to the displayed temperature.

In this case, depress HOT switch () or COLD switch in step 6. Each time the switch is depressed, displayed temperature will change by 0.5°C. In this way, sensed temperature can be varied in the range from +3.0 to -3.0°C.

(Example)

If the sensed temperature is set -3.0°C as shown at left with respect to the set display temperature of 25°C, the auto amplifier sensing temperature will be 22.0°C (25.0 - 3.0 = 22.0). Thus, the actual temperature is controlled at a level lower than the displayed temperature.

② Memorizing intake door position when turning ignition switch OFF

The intake door position when turning the ignition switch OFF can be memorized, and the air conditioner can be started at the memorized intake door position.

To use this function, depress REC switch () in step 6. This will cause the [AUTO] display to go out and the memory function to be activated. Pressing the REC switch again will cause [AUTO] to be displayed and the memory function canceled.

NOTE:

Even if condition ① or ② is set in step 6, the set condition will be canceled when the battery is disconnected. If step 6 is set at customer's request, it is necessary to explain this point to the customer.

H1 AIR CONDITIONER

1. Full Automatic Air Conditioner (Cont'd)

(8) Self-diagnostic procedure flowchart

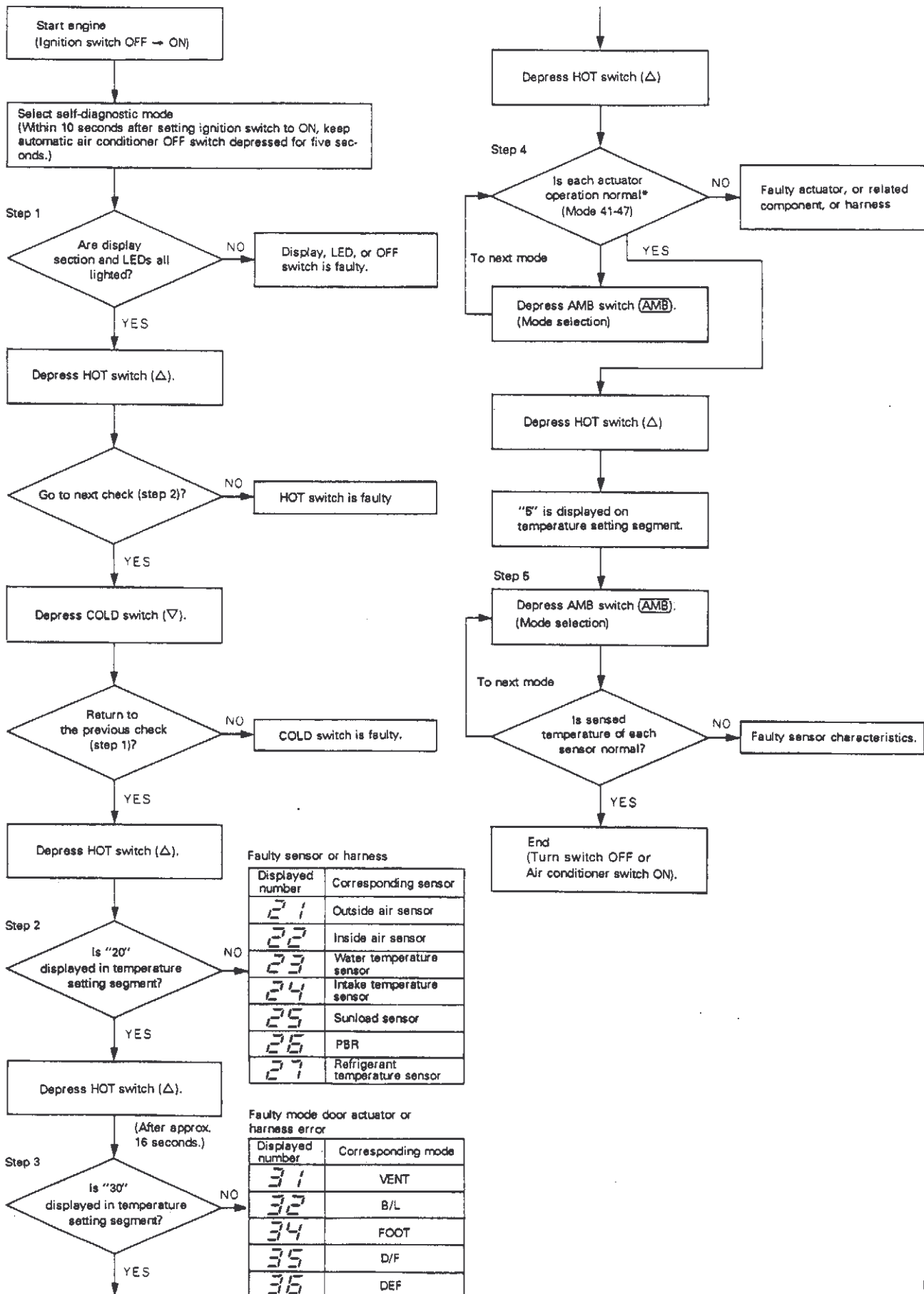

H1 AIR CONDITIONER

1. Full Automatic Air Conditioner (Cont'd)

1-4 SENSOR INSPECTION

(1) Outside air sensor

Disconnect outside air sensor connector, and measure resistance value between terminals on sensor side.

NOTE:

Perform this check with ignition switch set in OFF position. If the outside air sensor connector or auto amplifier connector is disconnected with the ignition switch ON, the outside air temperature is sensed as extremely low. If the connector is connected after turning the ignition switch OFF, and if the ignition switch is set again to ON, the outside air temperature correcting function prevents the sensing value from rising quickly to correct level. As a result, the compressor remains OFF, and heating function operates. In this case, disconnect the outside air sensor with the ignition switch ON, and then reconnect the sensor connector.

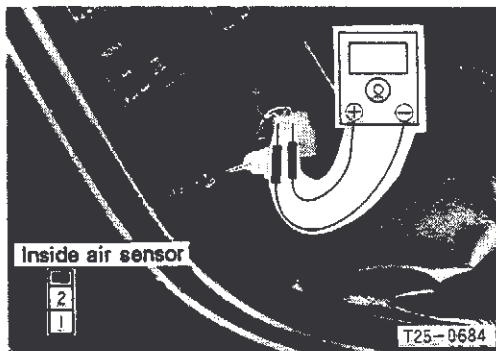
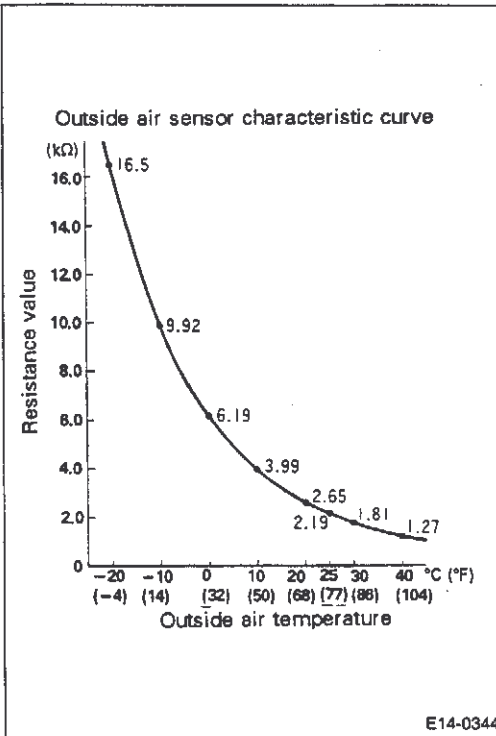
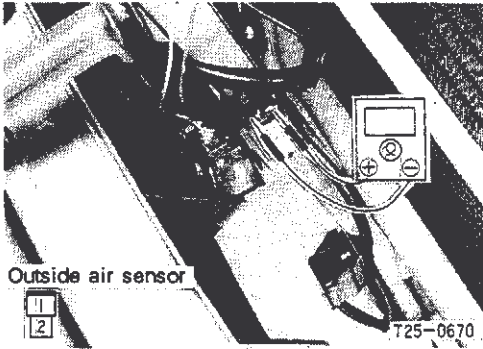

(2) Inside air sensor

Disconnect inside air sensor connector, and measure resistance between terminals on sensor side.

H1 AIR CONDITIONER

1. Full Automatic Air Conditioner (Cont'd)

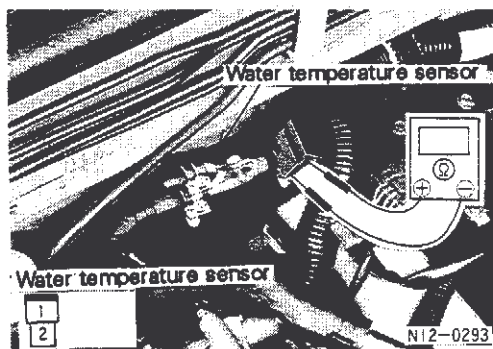
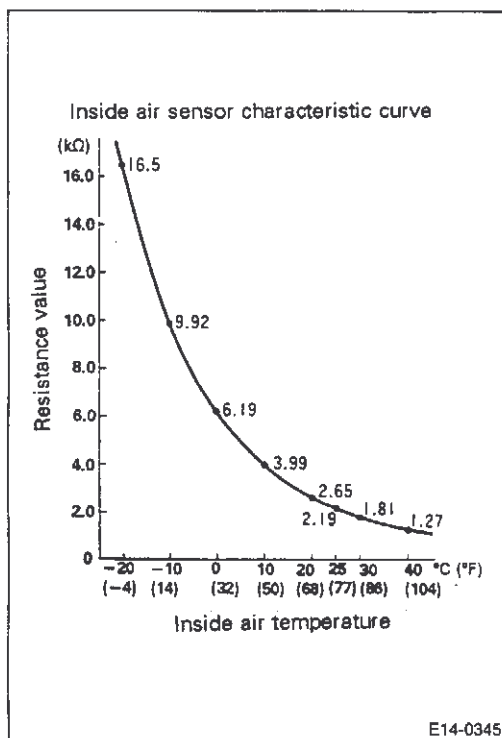

(3) Water temperature sensor

Disconnect water temperature sensor connector, and measure resistance value between terminals on sensor side.

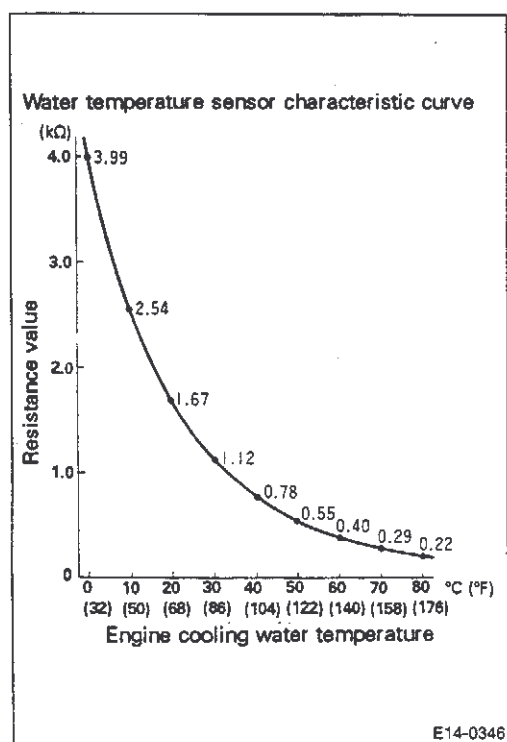

H1 AIR CONDITIONER

1. Full Automatic Air Conditioner (Cont'd)

(4) Intake air temperature sensor

Disconnect intake air temperature sensor connector, and measure resistance between terminals on sensor side.

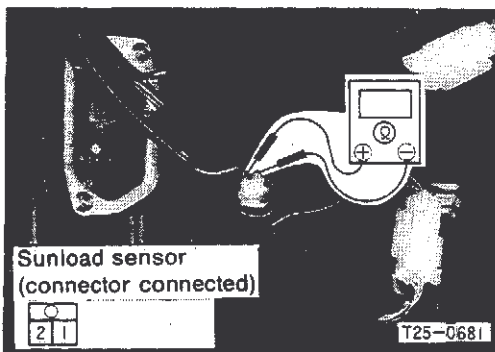
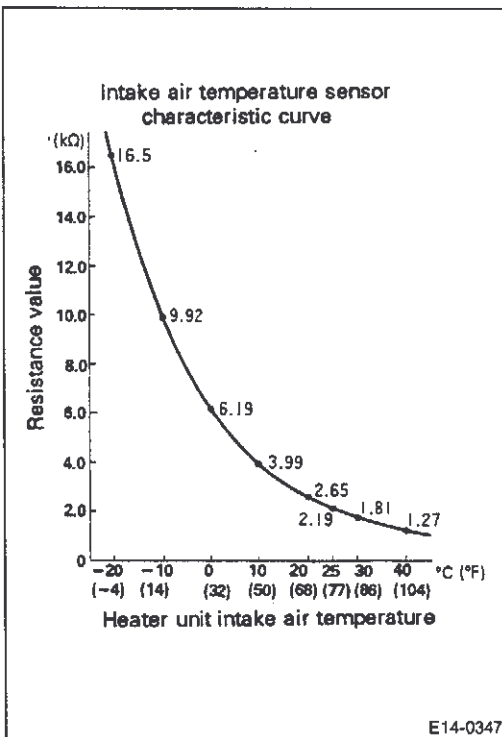
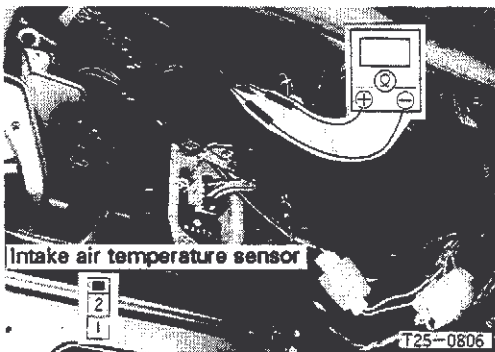

(5) Sunload sensor

With sunload sensor connector connected, measure voltage between terminals.

Ignition switch	Terminals		Standard value
	Positive ⊕	Negative ⊖	
ON	①	②	See characteristic curve.

NOTE:

When performing this check indoors, move a 60 watt lamp toward or away from sensor while reading voltage.

Reference: Sunload by direct sunlight during fine weather is equivalent to 0.768 kW (660 kcal/h, 2,619 BTU/h)/m² [0.0713 kW (61.31 kcal/h, 243.4 BTU/h)/sq ft].

H1 AIR CONDITIONER

1. Full Automatic Air Conditioner (Cont'd)

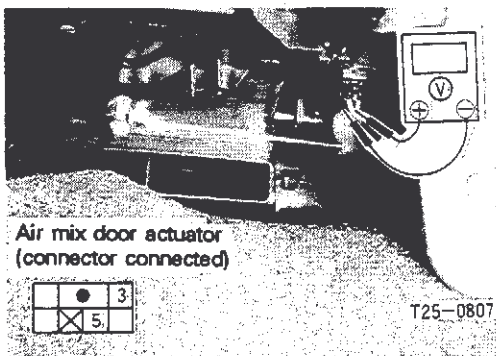
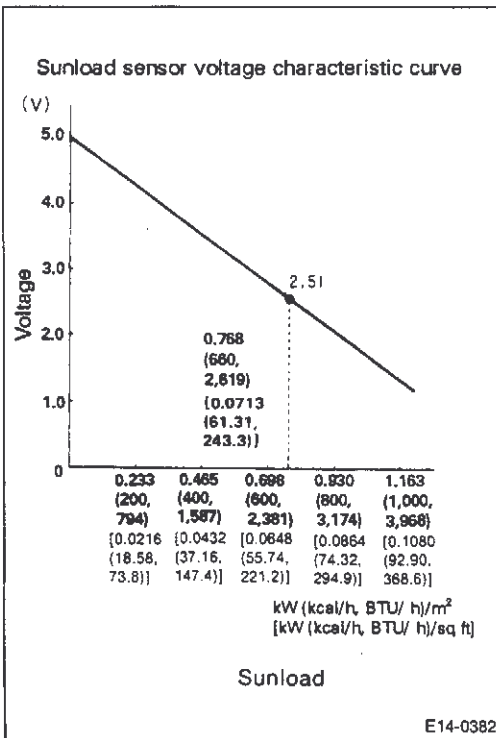

(6) PBR

With air mix door actuator connector connected, measure voltage between terminals.

Ignition switch	Terminals		Standard value
	Positive ⊕	Negative ⊖	
ON	3	5	See characteristic curve.

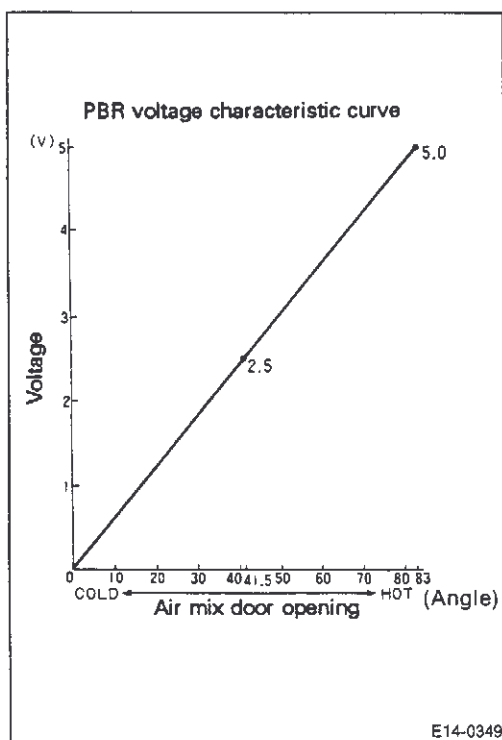

H1 AIR CONDITIONER

1. Full Automatic Air Conditioner (Cont'd)

(7) Refrigerant temperature sensor

Disconnect refrigerant temperature sensor connector, and measure resistance between terminals on sensor side.

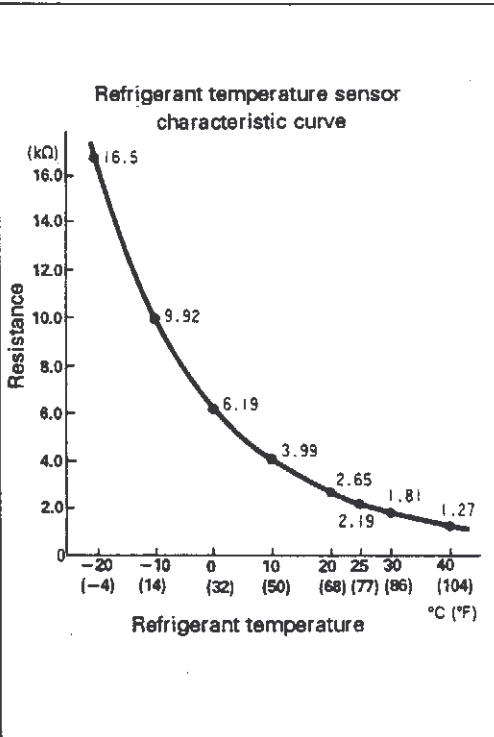
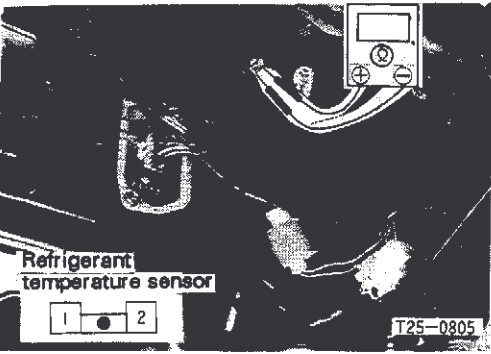

H1 AIR CONDITIONER

1. Full Automatic Air Conditioner (Cont'd)

1-5 ACTUATOR INSPECTION

(2) Intake door system

Before inspection, check intake door actuator and automatic amplifier connectors.

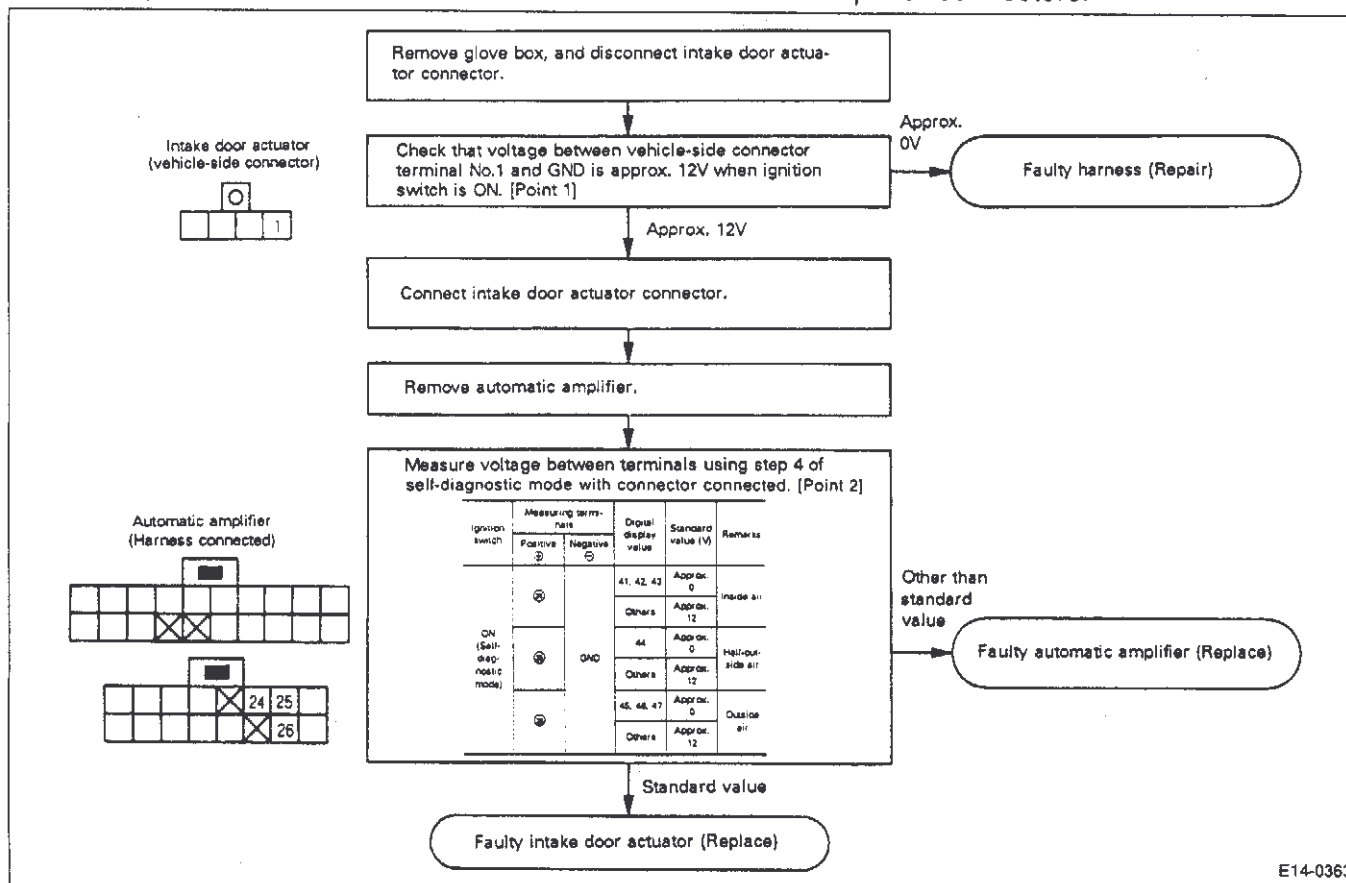

(2) Air mix door system

Before inspection, check air mix door actuator and automatic amplifier connectors.

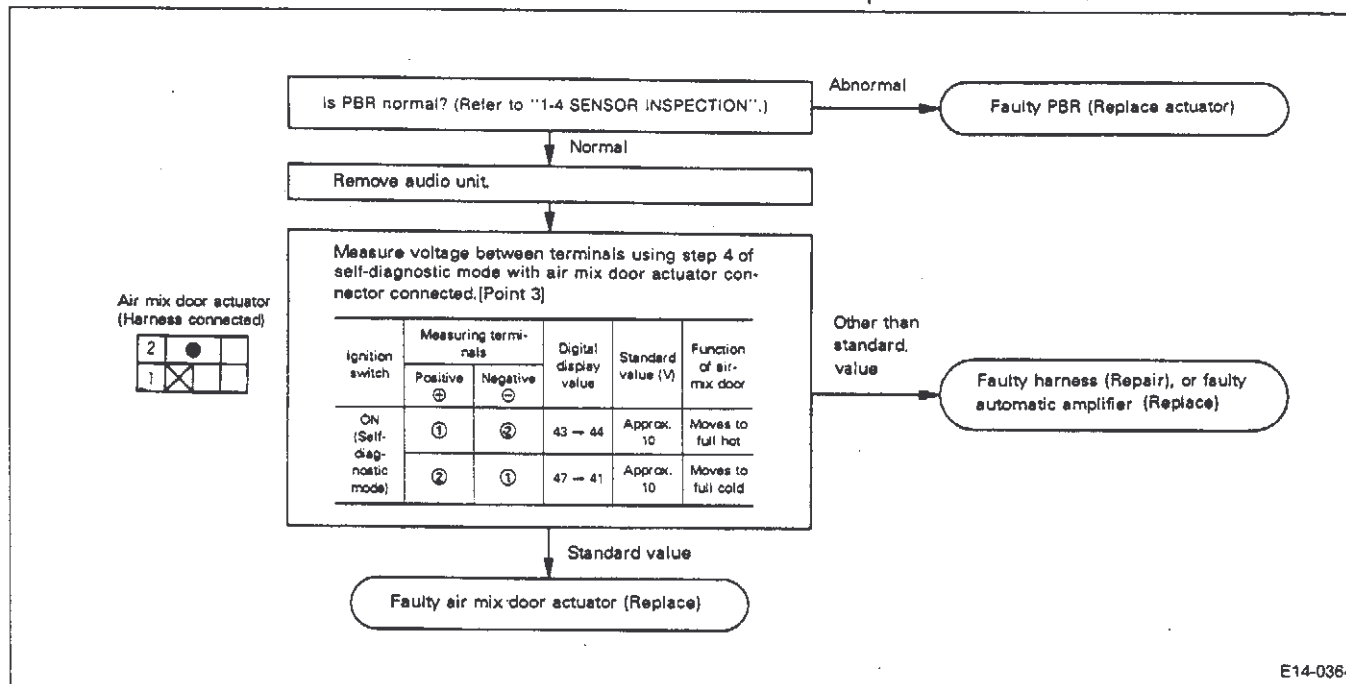

H1 AIR CONDITIONER

1. Full Automatic Air Conditioner (Cont'd)

[Point 1] Intake door actuator power inspection

- Remove intake door actuator, and measure voltage between vehicle-side connector and GND.

Measuring range	Ignition switch	Measuring terminals		Standard value
		Positive ⊕	Negative ⊖	
Ⓥ	ON	①	GND	Approx. 12V

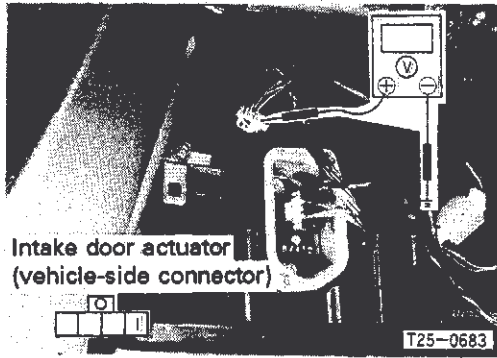

[Point 2] Automatic amplifier output inspection

- Remove automatic amplifier, and measure voltage by applying circuit tester probes to 16-terminal connector. Use step 4 of self-diagnostic mode and keep connector connected during measurement.

Measuring range	Ignition switch	Measuring terminal		Digital display value	Standard value	Remarks
		⊕	⊖			
Ⓥ	ON (Self-diagnostic mode)	②④	GND	41, 42, 43	Approx. 0V	Inside air
				Others	Approx. 12V	
		②⑤		44	Approx. 0V	Half-outside air
				Others	Approx. 12V	
		②⑥		45, 46, 47	Approx. 0V	Outside air
				Others	Approx. 12V	

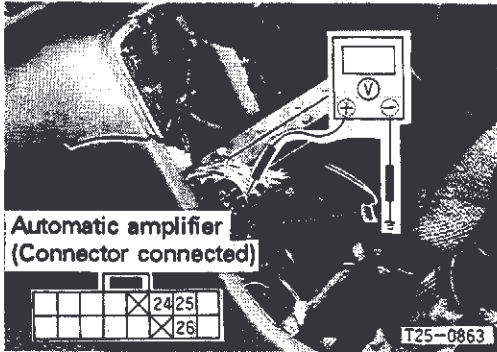

NOTE:

If standard value of approx. 12V is not present, internal circuit of intake door actuator may be disconnected.

H1 AIR CONDITIONER

1. Full Automatic Air Conditioner (Cont'd)

[Point 3] Automatic amplifier output inspection

- With air mix door actuator connector connected, measure voltage using step 4 of self-diagnostic mode.

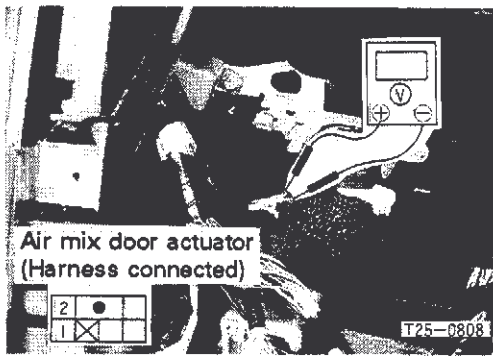

Measuring range	Ignition switch	Measuring terminal		Digital display value	Standard value	Function of air mix door
		⊕	⊖			
V	ON (Self-diagnostic mode)	①	②	43 → 44	Approx. 10V	Moves to full hot
		②	①	47 → 41	Approx. 10V	Moves to full cold

(3) Blower motor system

Before inspection, check blower motor, fan control amplifier, HI relay and automatic amplifier connectors.

① Blower motor fails to run in HI position.

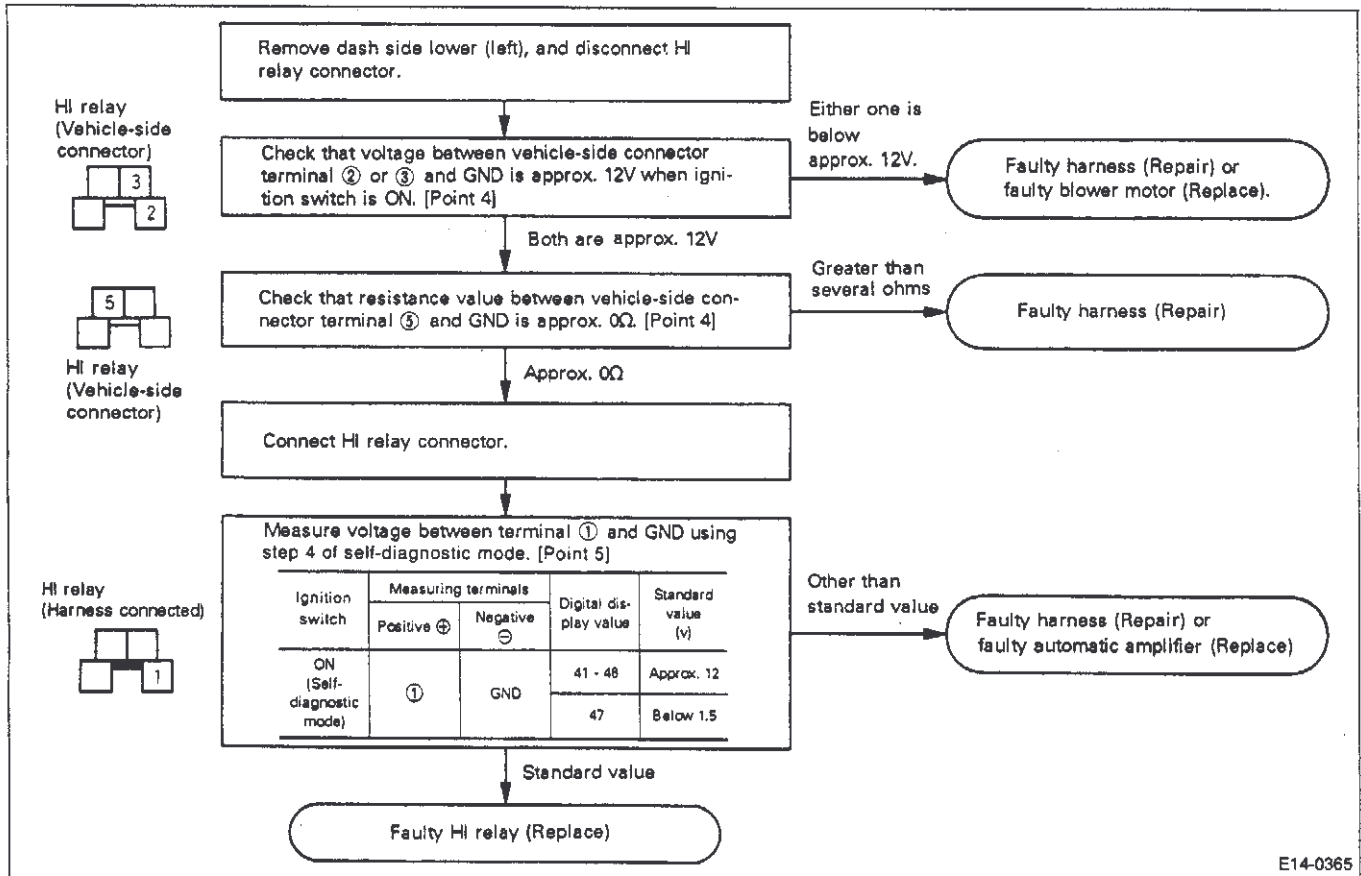

E14-0365

H1 AIR CONDITIONER

1. Full Automatic Air Conditioner (Cont'd)

② Unable to change blower motor speed, or motor fails to run at any position other than HI.

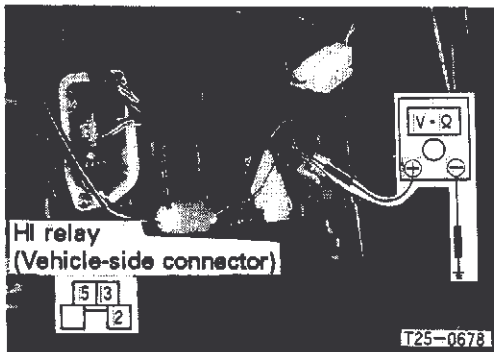
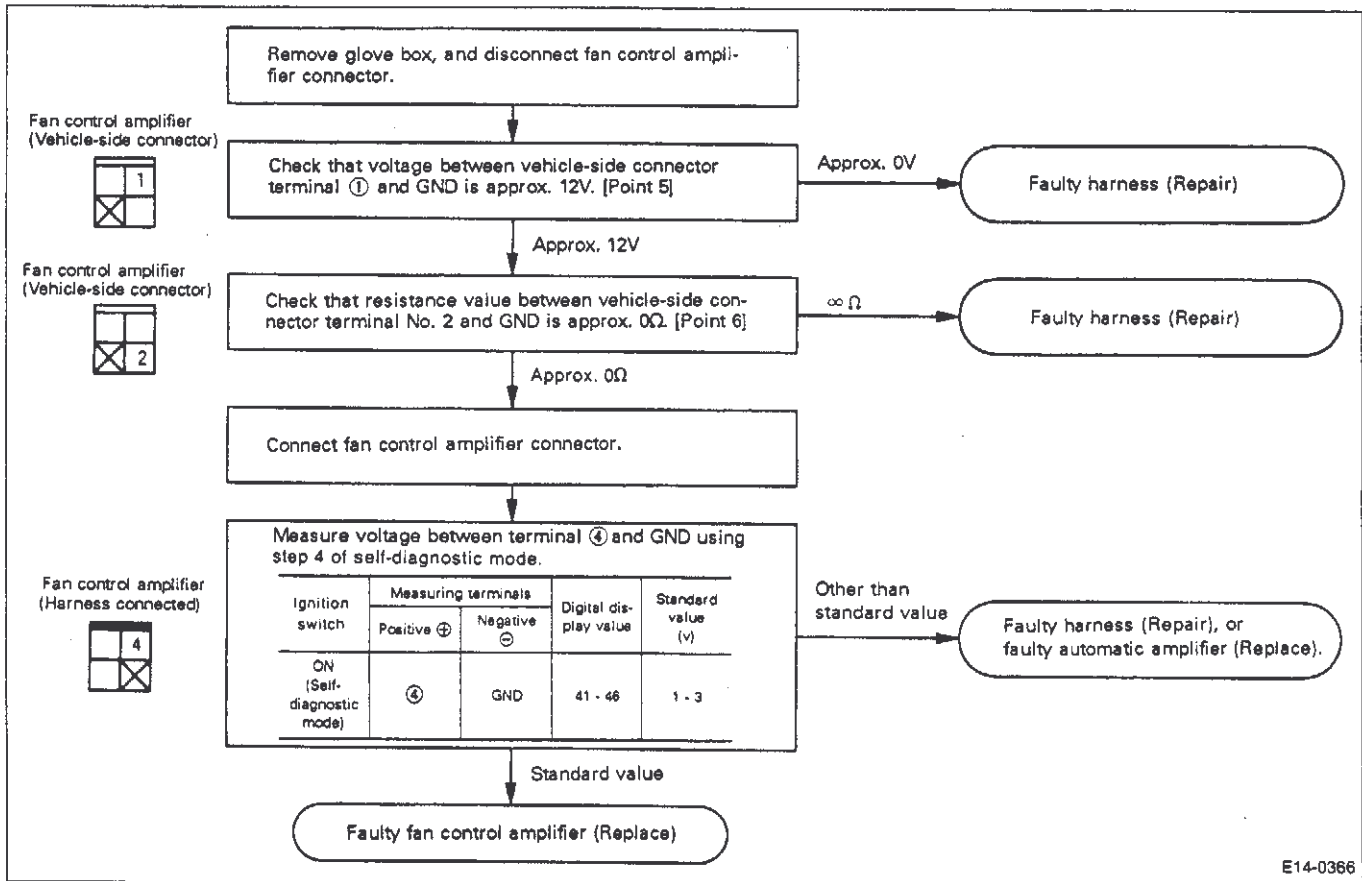

[Point 4] HI relay power and GND circuit inspection

- Disconnect HI relay connector, and measure voltage and check continuity between vehicle-side connector and GND.

Measuring range	Ignition switch	Fan switch	Measuring terminals		Standard value
			⊕	⊖	
V	ACC	OFF	③	GND	Approx. 12V
	ON		②		
Ω	OFF		⑤		0Ω

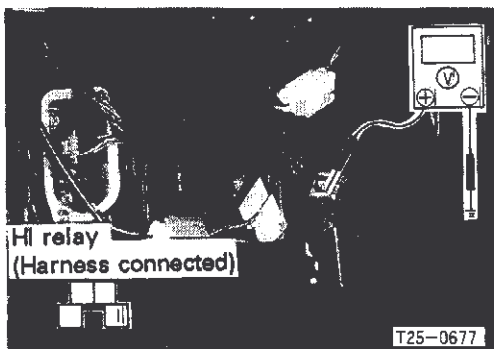

[Point 5] Automatic amplifier output inspection

- With HI relay connector connected, measure voltage using step 4 of self-diagnostic mode.

Measuring range	Ignition switch	Measuring terminals		Digital display value	Standard value
		⊕	⊖		
V	ON (Self-diagnostic mode)	①	GND	41 - 46	Approx. 12V
				47	

H1 AIR CONDITIONER

1. Full Automatic Air Conditioner (Cont'd)

[Point 6] Fan control amplifier power and GND circuit inspection

- Disconnect fan control amplifier connector, and measure voltage and check continuity between vehicle-side connector and GND.

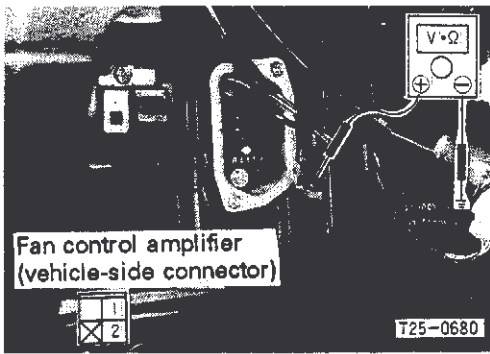

Measuring range	Ignition switch	Fan switch	Measuring terminals		Standard value
			⊕	⊖	
V	ACC	OFF	①	GND	Approx. 12V
Ω	OFF		②		0Ω

[Point 7] Automatic amplifier output inspection

- With fan control amplifier connector connected, measure voltage using step 4 of self-diagnostic mode.

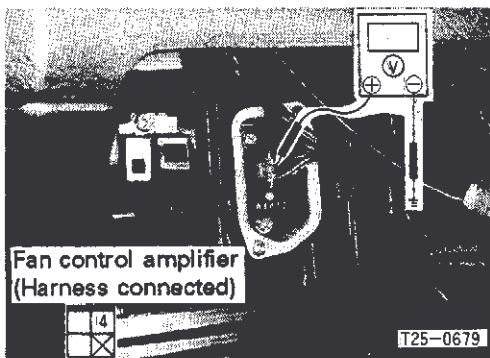

Measuring range	Ignition switch	Measuring terminals		Digital display value	Standard value
		⊕	⊖		
V	ON (Self-diagnostic mode)	④	GND	41 - 46	1 - 3V

H1 AIR CONDITIONER

1. Full Automatic Air Conditioner (Cont'd)

(4) Compressor system

Before inspection, check air conditioner relay, dual pressure switch, automatic amplifier magnet clutch connectors.

① Magnet clutch system

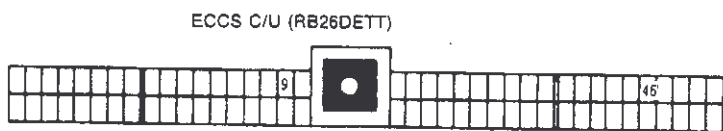
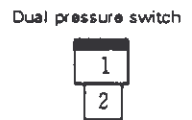
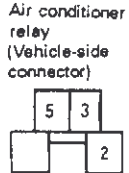
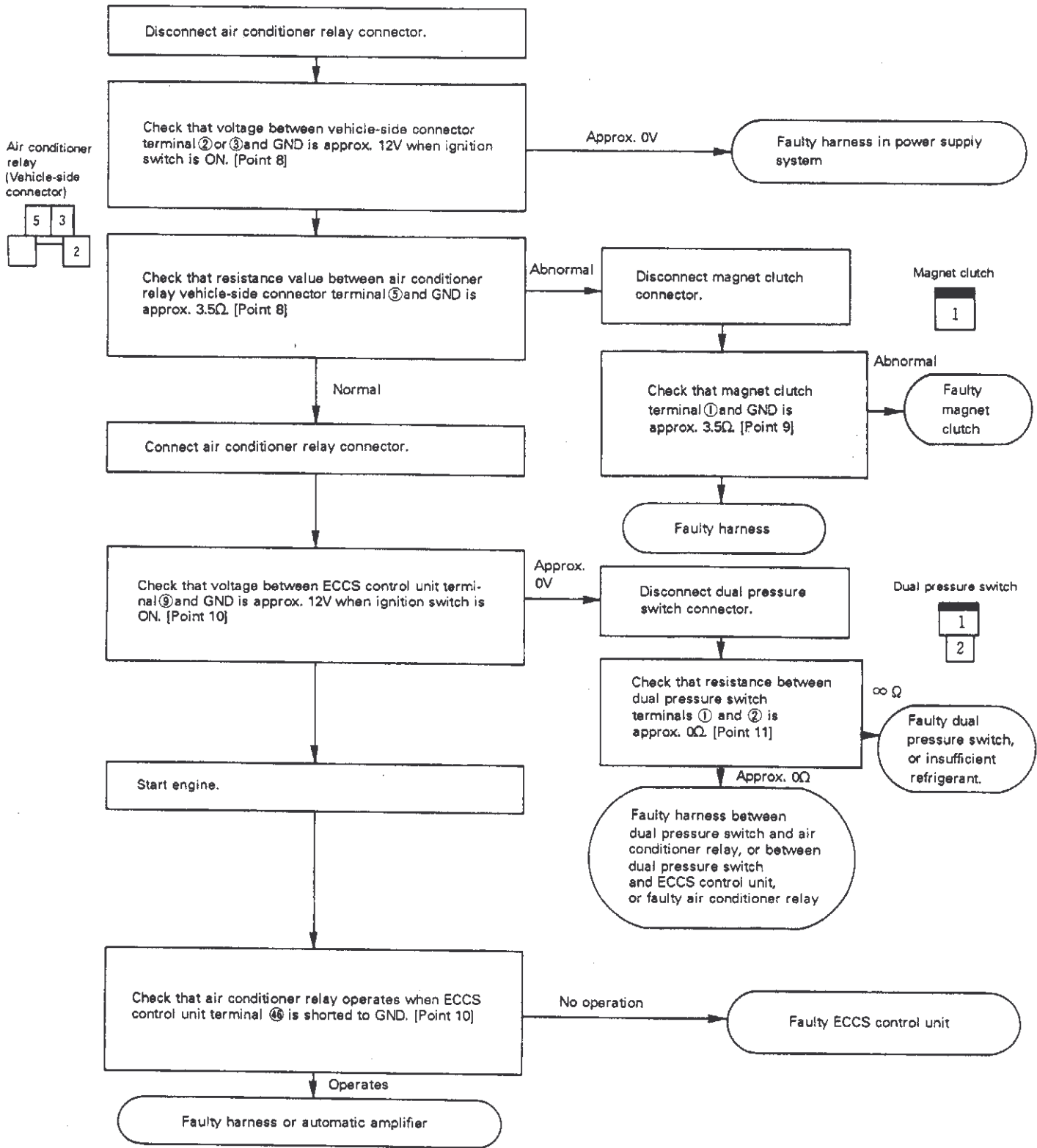

H1 AIR CONDITIONER

1. Full Automatic Air Conditioner (Cont'd)

[Point 8] Air conditioner relay power supply and magnet clutch circuit inspection

- Remove air conditioner relay, and measure voltage and resistance between vehicle-side connector and GND.

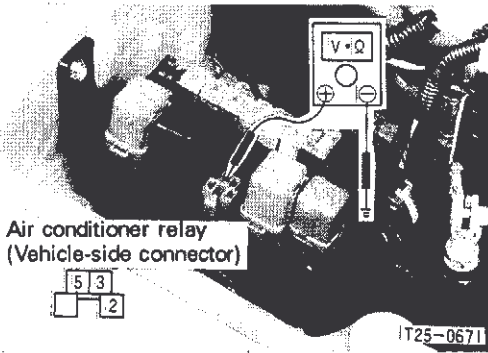

Measuring range	Ignition switch	Measuring terminal		Standard value	Remarks
		⊕	⊖		
V	ON	②	GND	Approx. 12V	IGN power
	ACC	③			ACC power
Ω	OFF	⑤		Approx. 3.5Ω	Magnet clutch coil resistance

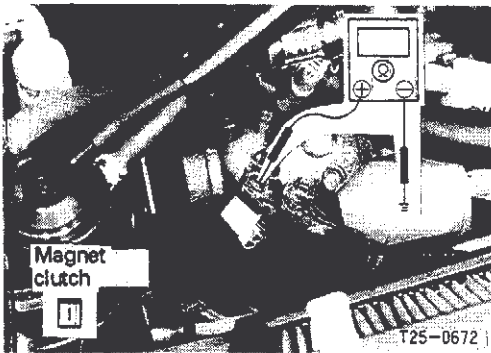

[Point 9] Magnet clutch inspection

- Disconnect magnet-clutch connector, and measure resistance between clutch-side connector and GND.

Measuring range	Measuring terminals		Standard value
	⊕	⊖	
Ω	①	GND	Approx. 3.5Ω

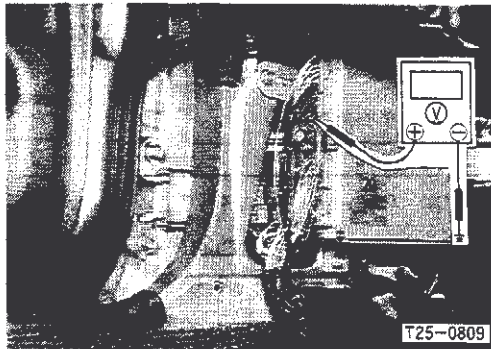

[Point 10] Air conditioner control circuit inspection

- With harness connected to ECCS control unit, measure voltage and check relay operation by applying tester probes as shown.

① Air conditioner control circuit inspection

Measuring range	Ignition switch	Measuring terminals		Standard value
		⊕	⊖	
V	ON	⑨	GND	Approx. 12V

② Air conditioner relay operation inspection

Ignition switch	Terminal to be shorted to GND	Air conditioner relay operation
ON (Engine is running)	④	Air conditioner relay must turn ON.

H1 AIR CONDITIONER

1. Full Automatic Air Conditioner (Cont'd)

[Point 11] Dual pressure switch continuity inspection

- Disconnect dual pressure switch connector, and measure resistance by applying tester probes to switch side connector as shown.

Measuring range	Measuring terminals	Standard value
Ω	① - ②	Approx. 0Ω

NOTE:

If dual pressure switch is OFF, the cause may be a faulty air conditioner cycle.

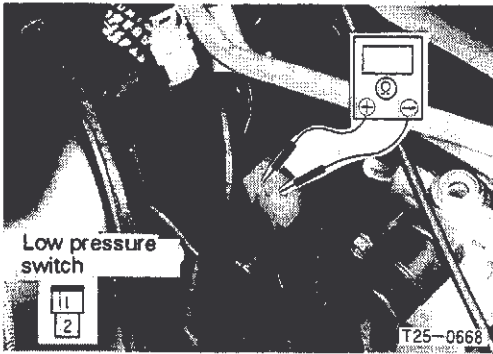

② Control valve system

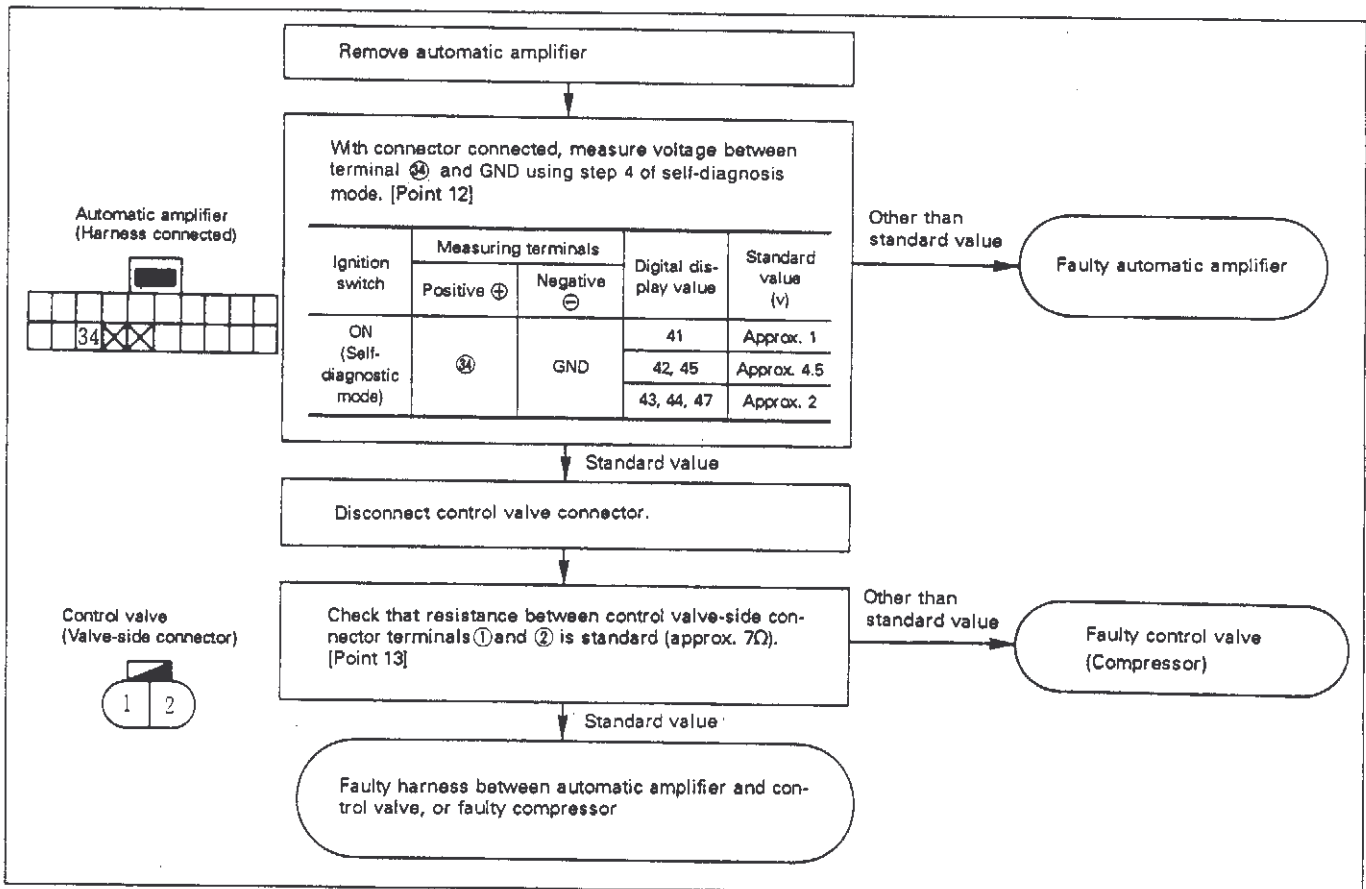

H1 AIR CONDITIONER

1. Full Automatic Air Conditioner (Cont'd)

[Point 12] Automatic amplifier output signal inspection

- Remove automatic amplifier. With connector connected, measure voltage by applying tester probes to the 20-terminal connector using step 4 of self-diagnostic mode.

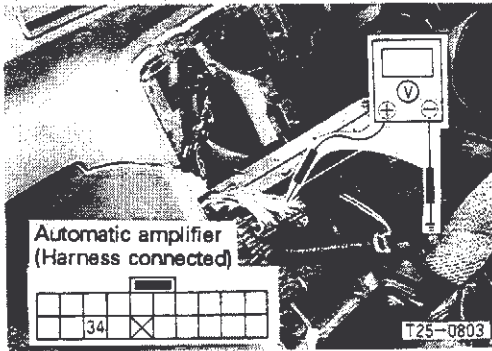

Measuring range	Ignition switch	Measuring terminals		Digital display value	Standard value
		⊕	⊖		
Ⓥ	ON (Self-diagnostic mode)	34	GND	41	Approx. 1V
				42, 45	Approx. 4.5V
				43, 44, 47	Approx. 2V

[Point 13] Coil resistance inspection in control valve

- Disconnect control valve connector, and measure resistance of coil by applying tester probes to valve-side connector.

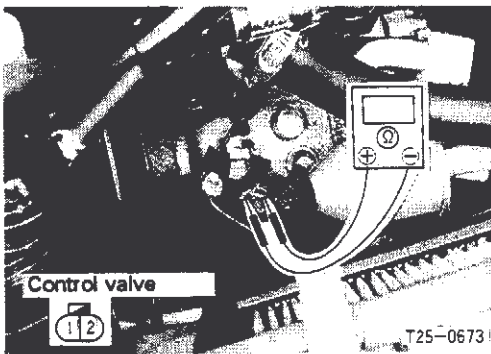

Measuring range	Measuring terminals	Standard value
Ω	① - ②	Approx. 7Ω

1-6 ACTUATOR REMOVAL AND INSTALLATION

(1) Intake door actuator

Removal

Remove and install: Glove box, glove box cover (Parts not shown)

- Remove harness and securing bolts (two), and remove intake door actuator.

NOTE:

Remove actuator in REC state.

Installation

- Connect intake door actuator connector to vehicle harness.
- Set ignition switch to ACC, and set push control REC switch to ON. (Actuator is set in REC state.)
- Install intake door actuator while fixing actuator link in inside air position.
- Operate REC switch to see if actuator link is movable over full stroke range.

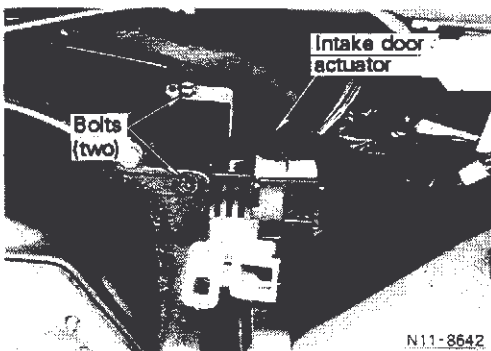

H1 AIR CONDITIONER

1. Full Automatic Air Conditioner (Cont'd)

(2) Air mix door actuator

Removal

Remove and install: Automatic transmission finisher, cluster lid C, audio unit, heater nozzle (left)

- Remove connector and securing bolts (three), and remove rod from rod holder.

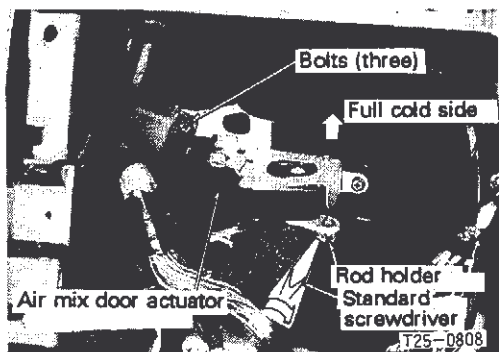

Installation

- Connect air mix door actuator connector to vehicle-side harness.
- Set ignition switch to ON, and activate self-diagnostic mode step 4, then set full cold status (display value 41, 42, or 43). After this, turn OFF ignition switch.
- Install air mix door actuator.
- Fix air mix door actuator to rod holder while pressing door link toward full cold (driver seat).
- Activate step 4 of self-diagnostic mode. Make sure that air mix door moves over full stroke range when display value is changed from 43 to 44 or from 47 to 41.

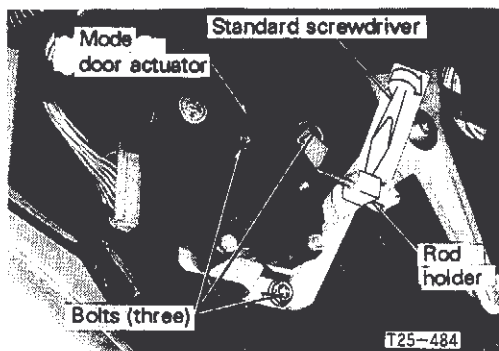

(3) Mode door actuator removal and installation

Removal

Remove and install: Instrument panel lower cover

- Remove connector and securing bolts (three), and remove rod by rotating rod holder with standard screwdriver.

NOTE:

Remove rod holder in DEF state.

Installation

- Connect mode door actuator connector to vehicle-side harness.
- Set ignition switch to ACC, and set push control DEF switch to ON. (Actuator is set in DEF state.)
- Install mode door actuator.
- Fix side link to rod holder while holding side link in DEF mode position (by rotating counterclockwise until it stops).
- Operate mode switch and make sure that side link is capable of moving over full stroke range.

ELECTRICAL SYSTEM

SECTION **EL**

CONTENTS

E BODY ELECTRICAL UNITS

E1 LIGHTS	EL- 2
1. Headlight Assembly	EL- 2
2. Backup Light (2-door model)	EL- 3
E2 INSTRUMENTS	EL- 4
1. Combination Meter	EL- 4
2. Sub Meter	EL- 5
E3 AUDIO UNITS	EL- 7
1. Antenna	EL- 7
E4 WINDOW EQUIPMENT	EL- 8
1. Windshield Wipers	EL- 8
2. Window Washer	EL-10
E5 ELECTRICAL WIRING DIAGRAMS	
Abbreviations and Cable Colours	EL-11
Relays and Fuses	EL-12
WIRING DIAGRAMS	
– C-1 4WD vehicles (RB20DET/RB26DETT)	Fig. No. 1
– W-1 4WD vehicles (RB20DET/RB26DETT)	Fig. No. 2
– RB26DETT Engine Harness	Fig. No. 3
– E-TS System	Fig. No. 5
– Door Harness	Fig. No. 6
– Hicas System	Fig. No. 7
– Air Conditioner	Fig. No. 8

E1 LIGHTS

1. Headlight Assembly

1-1 HEADLIGHT REMOVAL AND INSTALLATION

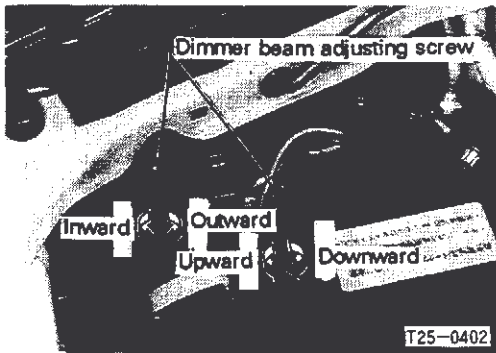
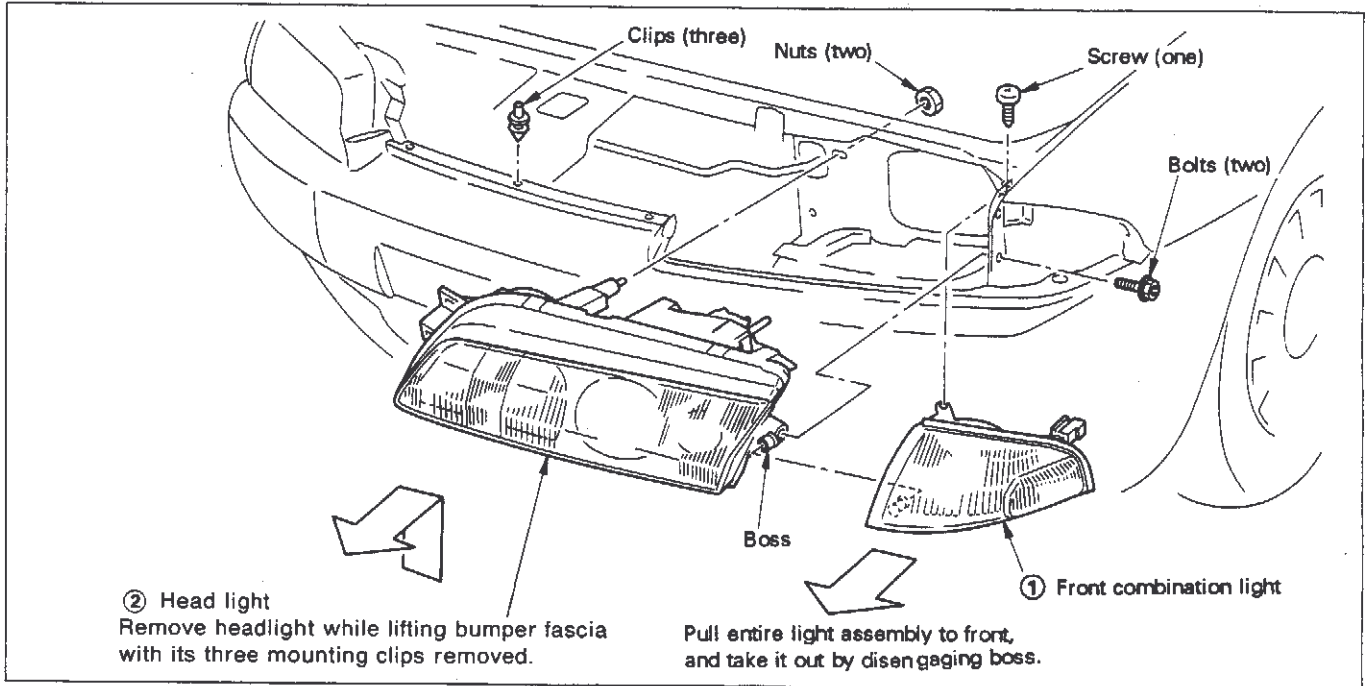

1-2 AIMING HEADLIGHT

- Refer to the Basic Service Manual <A801001> for headlight aiming procedures.

(1) Modified 4-bulb type projector headlight

- ① Dimmer beam

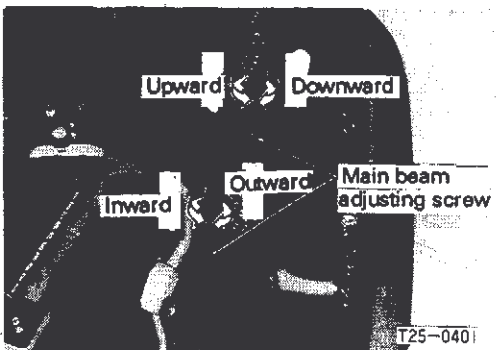

- ② Main beam

E1 LIGHTS

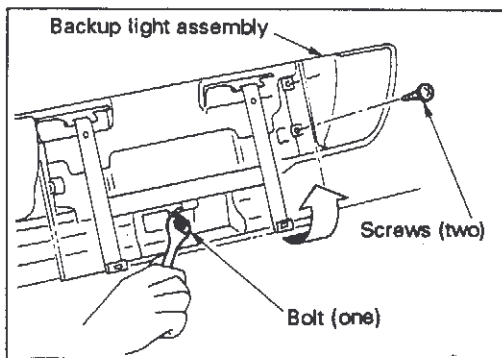

2. Backup Light (2-door model)

2-1 BACKUP LIGHT REMOVAL AND INSTALLATION

Removal

- Remove license plate bracket securing bolt (one), and pull up license plate, then remove light securing screws (two), and then remove backup light.
- Replace bulb after removing light main body.

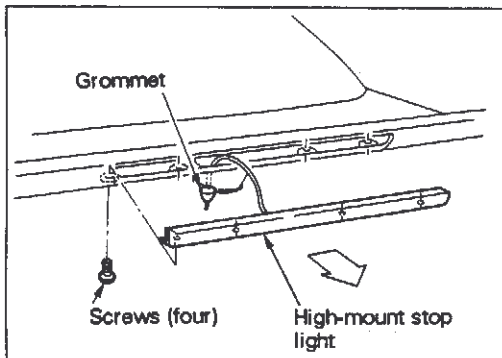

3. High-mount Stop Light (2-door model)

3-1 LIGHT REMOVAL AND INSTALLATION

Removal

- Remove light securing screws (four), and remove connector from light main body.

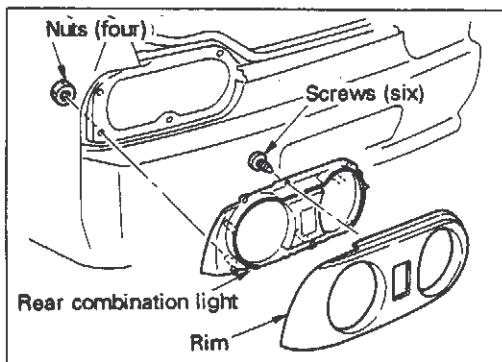

4. Rear Combination Light

4-1 LIGHT REMOVAL AND INSTALLATION

(1) 2-door model

Removal

Remove and install: Trunk rear finisher

- Heat sealing material fitted around rear combination light using drier and remove light assembly from trunk side.

Installation

- Remove butyl seal from body surface and rear side of light, and apply repair butyl seal to rear surface of rear combination light assembly. Install light assembly after heating butyl seal using dryer.

E2 INSTRUMENTS

1. Combination Meter

1-1 COMPONENTS

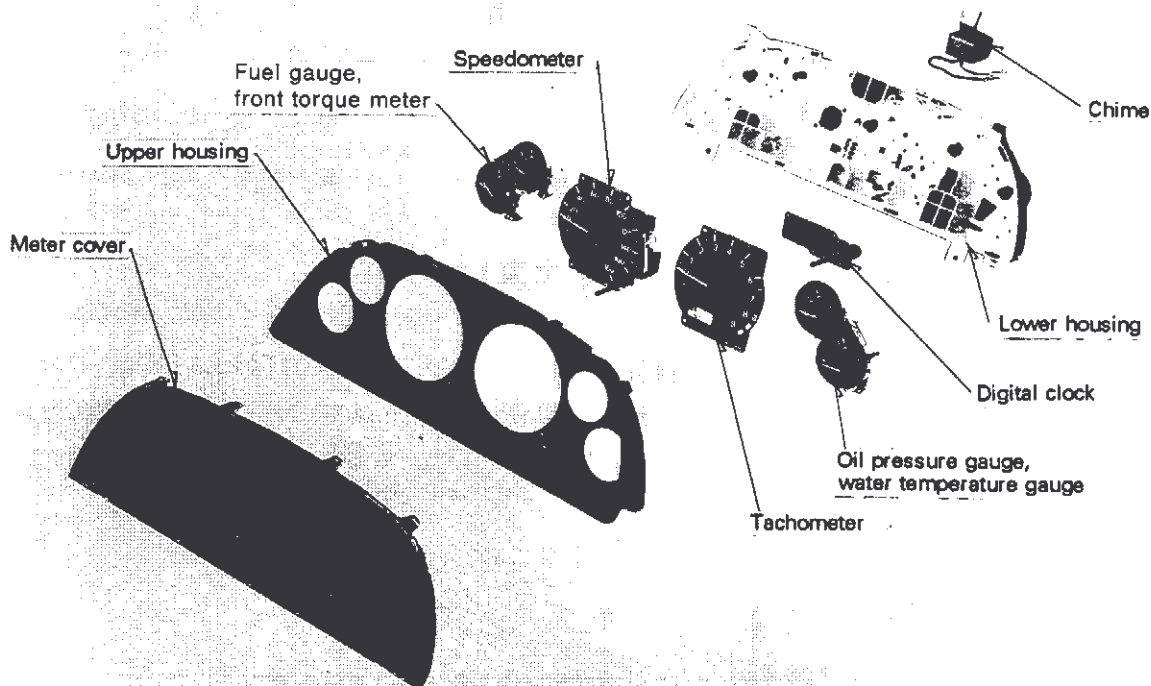

1. Combination Meter (GT-R model)

1-2 REAR SIDE SHAPE AND INTERNAL CIRCUIT

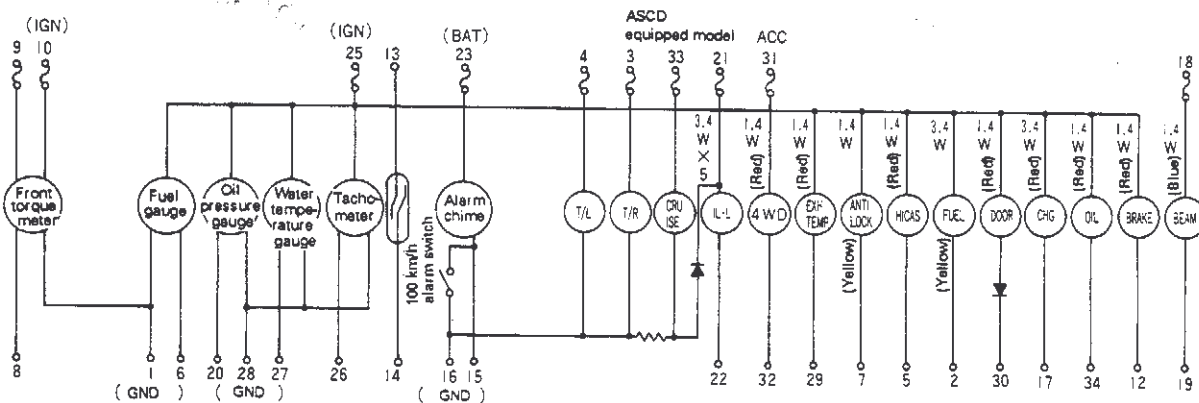
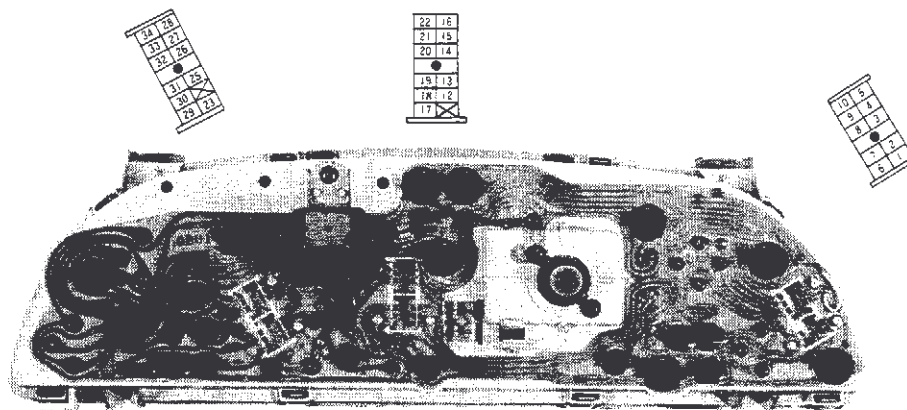

E2 INSTRUMENTS

2. Sub Meter

2-1 METER REMOVAL AND INSTALLATION

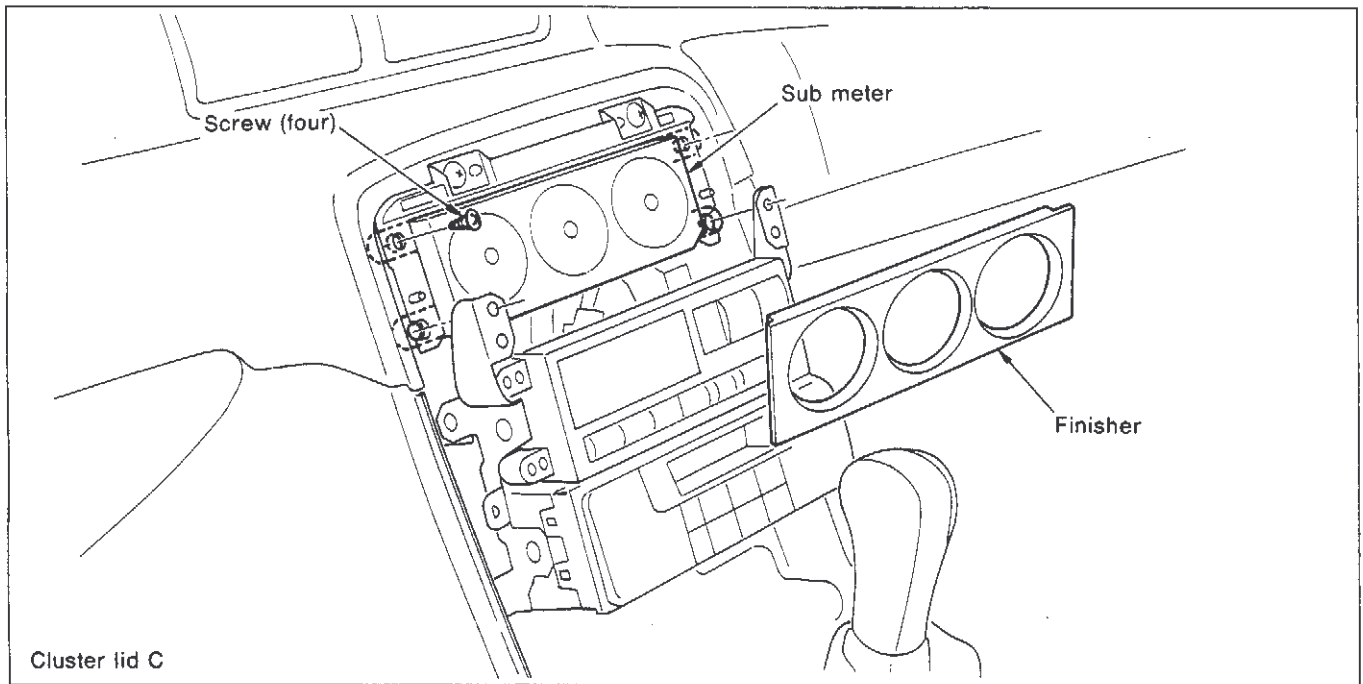

2-2 DISASSEMBLY

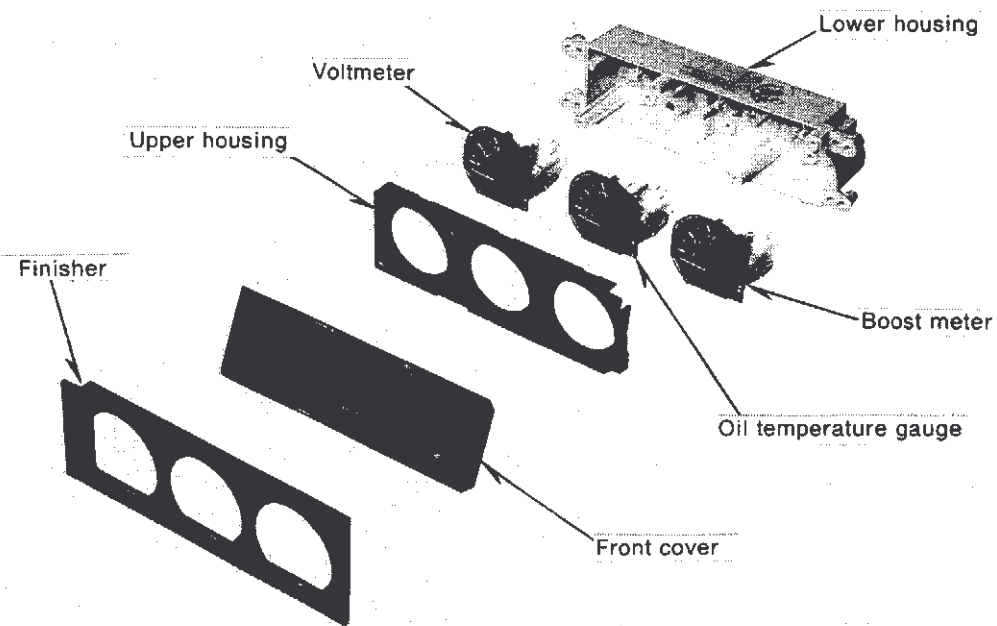

N12-1685

E2 INSTRUMENTS

2. Sub Meter (Cont'd)

2-3 REAR SIDE SHAPE AND INTERNAL CIRCUIT

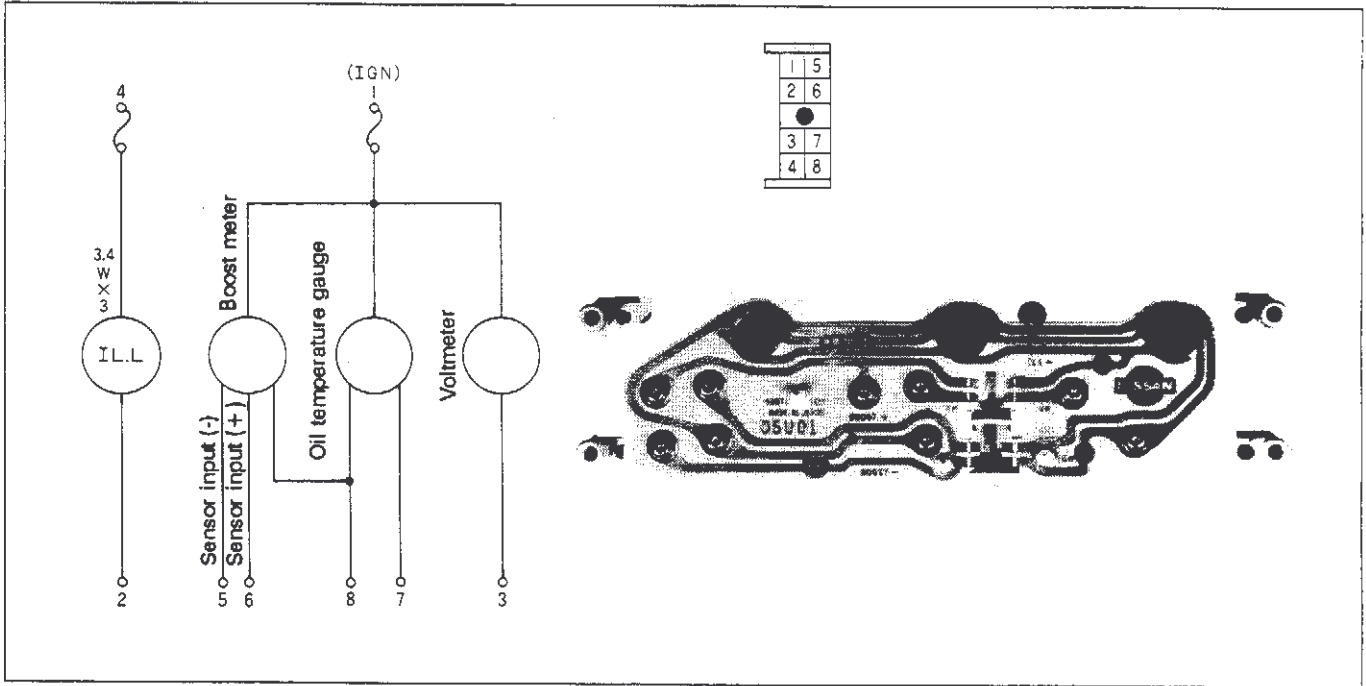

E3 AUDIO UNITS

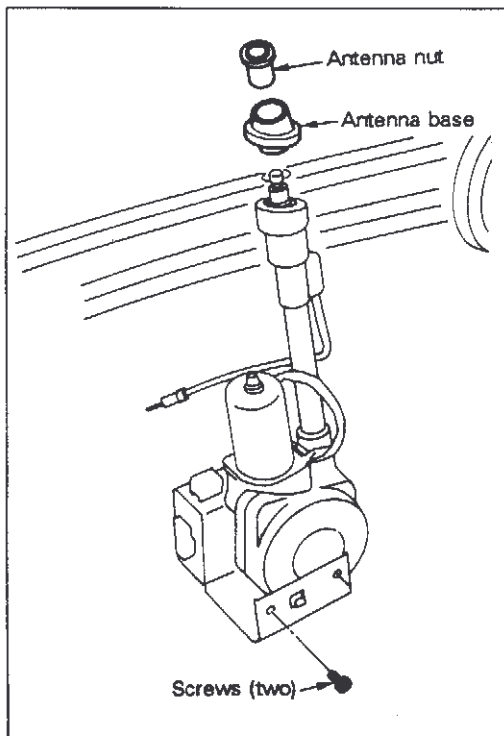

1. Antenna

1-1 FULL AUTOMATIC ANTENNA ASSEMBLY REMOVAL AND INSTALLATION

Remove and install: Trunk side finisher (left) (Parts not shown)

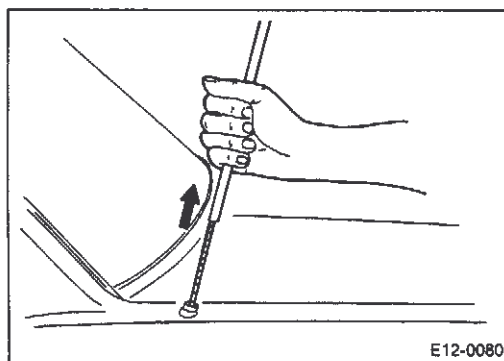

1-2 ANTENNA ROD REPLACEMENT

Removal

- Remove antenna nut and antenna base.
- Turn ON radio receiver power switch to raise antenna.
- At this moment, antenna rod and antenna rope can be pulled out by another operator.

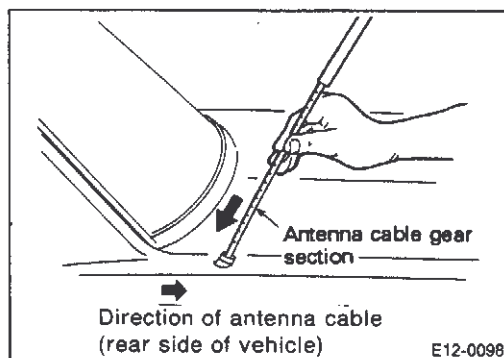

Installation (only when installing new part)

- Extend antenna cable end so that it can be easily taken up with motor.
- Turn OFF radio receiver power switch to retract antenna.
- Operator standing outside vehicle: Insert antenna cable into rod hole with gear side facing antenna motor (rear side of vehicle). After confirming that antenna cable has wound around motor, set root portion of rod into pipe, and allow motor to completely retract antenna rod.

NOTE:

If motor stops during operation, turn radio receiver ON then OFF to rotate motor in retracting direction.

Replacement rod part No.

28215 89904

E4 WINDOW EQUIPMENT

1. Windshield Wipers

1-1 FRONT WIPER

(1) Wiper arm and link removal and installation

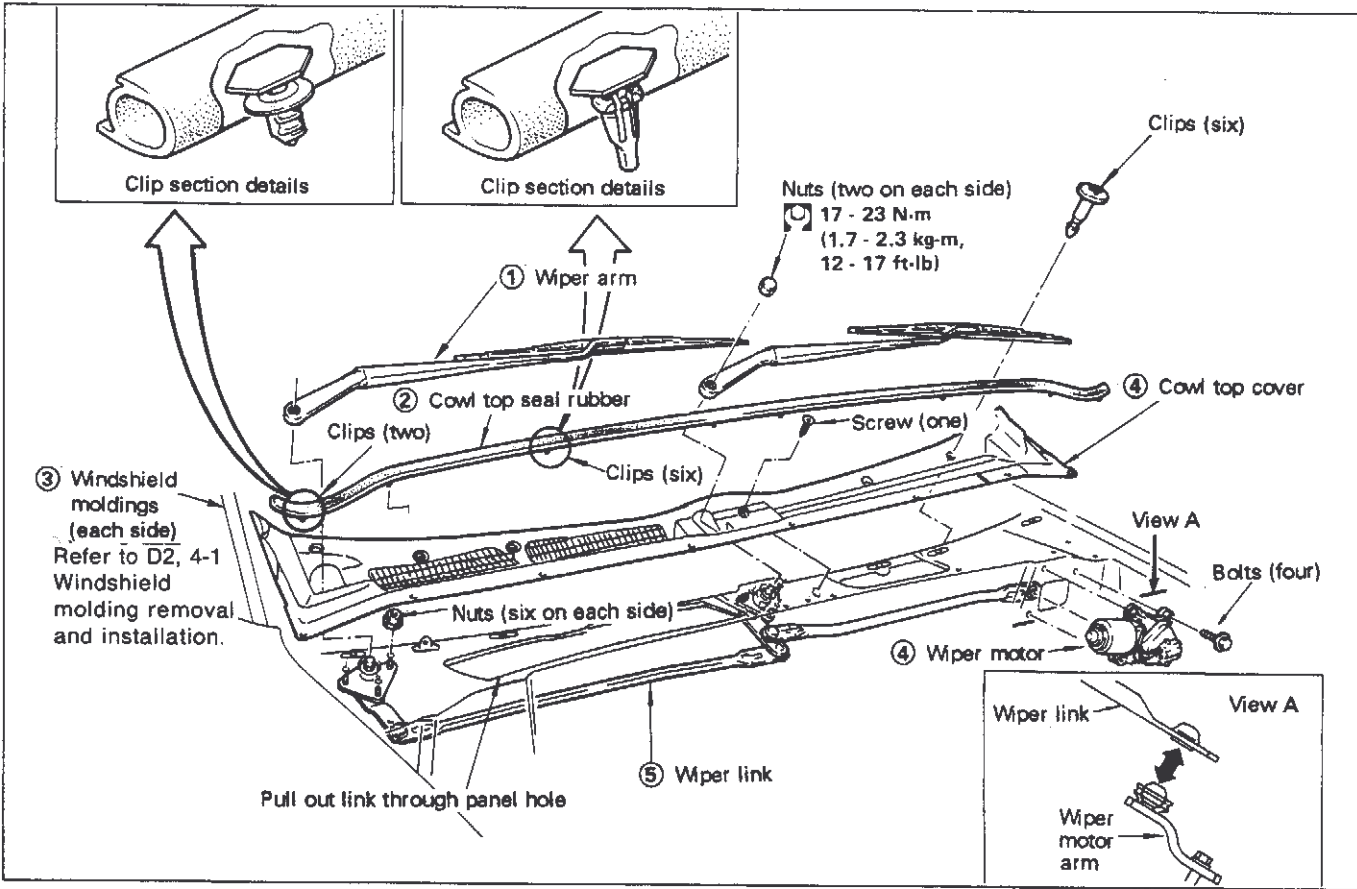

NOTE:

If wiper link comes off specified auto stop position, motor may start rotating even though wiper switch is OFF. To prevent this accident, be sure to keep wiper motor disconnected.

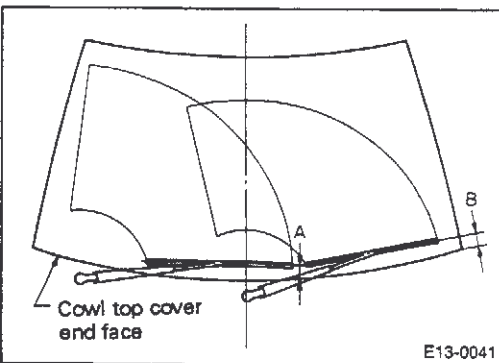

Wiper arm stop position

(2) Wiper arm adjustment

- When adjusting wiper arm, operate wiper motor once and allow it to stop at auto stop position.
- When installing wiper arm, align wiper blade end at specified position (wiper arm stop position), and tighten arm while paying attention to avoid movement of wiper link.

NOTE:

If wiper arm stop position has moved due to weight of snow or other external force, first correct wiper pivot fitting portion, then re-install wiper arm in correct position.

E4 WINDOW EQUIPMENT

1. Windshield wipers (Cont'd) Semi-concealed type (standard)

Unit: mm (in)

Dimension A	17 - 32 (0.67 - 1.26)
Dimension B	23 - 37 (0.91 - 1.46)

1-2 REAR WIPER

(1) Rear wiper arm and motor removal and installation

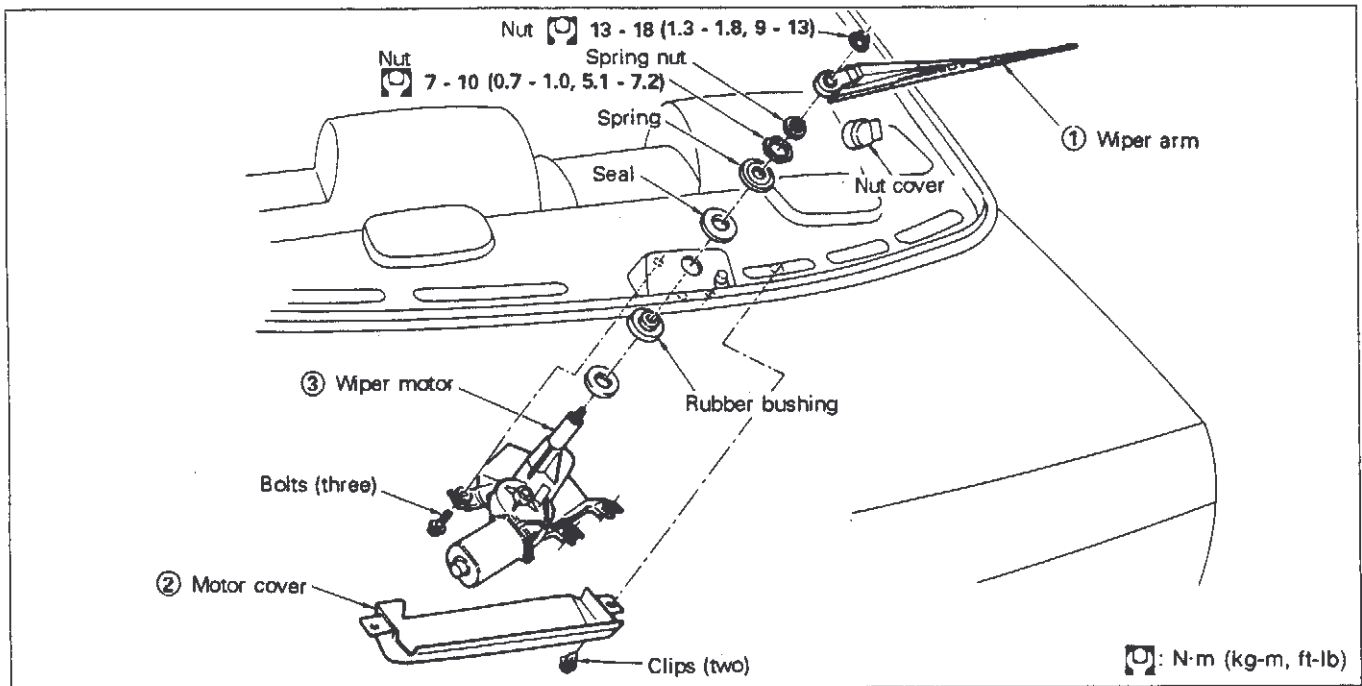

NOTE:

If wiper link comes off specified auto stop position, motor may start rotating even though wiper switch is OFF. To prevent this, be sure to keep wiper motor disconnected.

(2) Wiper arm adjustment

- When adjusting wiper arm position, operate wiper motor once, and allow it to stop at auto stop position.

Dimension A	17 - 32 mm (0.67 - 1.26 in)
-------------	-----------------------------

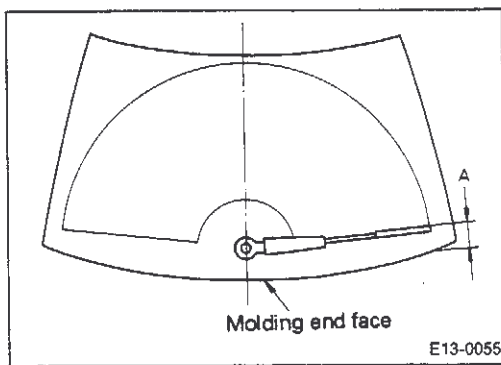

Wiper arm stop position

E4 WINDOW EQUIPMENT

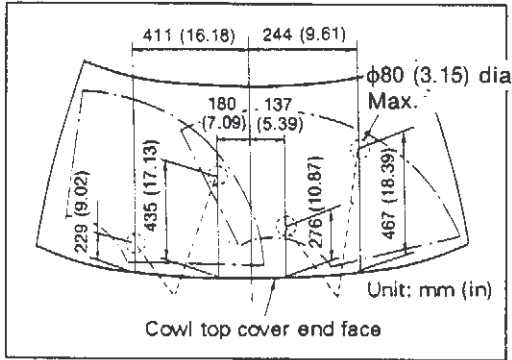

2. Window Washers

2-1 WASHER NOZZLE INJECTION POINT

(1) Front washer

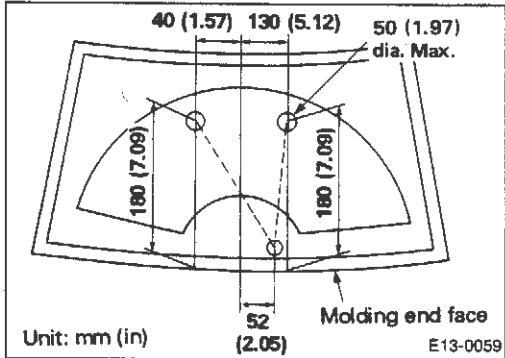

(2) Rear washer

2-2 WASHER NOZZLE ADJUSTMENT

(1) Front washer

- Paying attention not to deform injection nozzle opening, insert a needle into nozzle, and adjust nozzle direction.

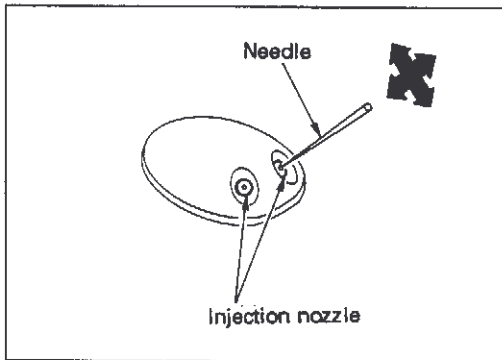

(2) Rear washer

- Adjust nozzle direction using a pipe with I.D. 3 mm (0.12 in). Pay attention not to damage nozzle port.

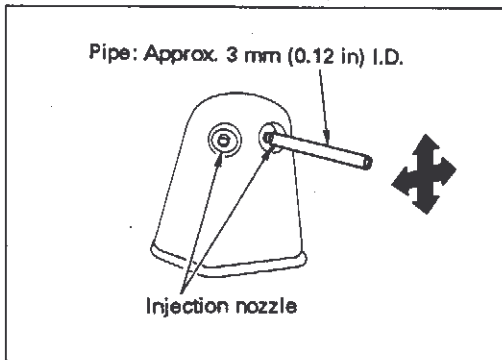

2-3 WASHER TANK

(1) Washer tank removal and installation

Remove and install: Air cleaner (Parts not shown)

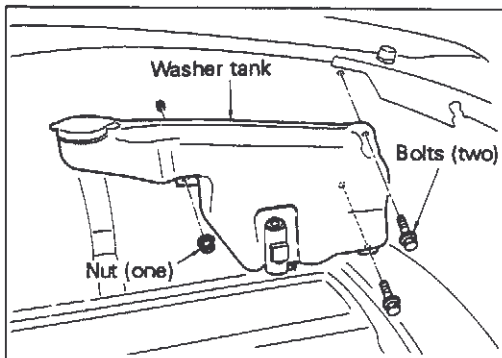

■ Chassis Marking Start Number

E-BNR32 vehicle BNR32-000001

■ Abbreviations

Abbreviation	Name	Abbreviation	Name
ACC	Accessory	AMP	Ammeter
A/C	Air conditioner	BUST	Vacuum gauge
A/P	Air purifier	FUEL	Fuel gauge
ASCD	Auto speed control device	OIL	Oil pressure gauge
A/T	Automatic transmission	OIL TEMP	Oil temperature gauge
C/B	Circuit breaker	TACHO	Tachometer
DSV	Double solenoid vacuum valve	TEMP	Water temperature gauge
ELR	Emergency locking retractor	VOLT	Voltmeter
EPS	Electronically controlled power steering	ANTI LOCK	4-wheel antiskid warning light
FICD	Fast idle control device	BATT	Battery fluid level warning light
F/L	Fusible link	BEAM	Main beam pilot lamp
IGN	Ignition	BELT	Seat belt warning light
IL CON	Illumination control	BRAKE	Brake warning light
ILL	Illumination light	CHECK	Check engine light
IND.L	Indicator light	CHG	Charge warning light
M/T	Manual transmission	CLUTCH	Clutch fluid level warning light
PBR	Potentiometer balance resistor	CRUISE	Cruise display light
P.L	Pilot lamp	DEF	Rear defogger pilot lamp
P/S	Power steering	DOOR	Open door warning light
PTC	Potentiometer temperature control	EXH TEMP	Exhaust gas temperature warning lamp
P/Tr	Power transistor	FAN BELT	Loose fan belt warning light
P/W	Power window	FILTER	Fuel filter water level warning light
ST	Start	FUEL	Low fuel level warning light
S/V	Solenoid valve	FUSE	Fuse blown warning light
SW	Switch	GLOW	Glow pilot lamp
Tr	Transistor	HICAS	Low HICAS oil level warning light
V/R	Voltage regulator	OIL	Oil pressure warning light
W.L	Warning light	RAD	Low radiator fluid level warning light
2WD	2-wheel drive	STOP	Stop light burnout warning light
4WAS	4-wheel antiskid	TAIL	Tail lamp burnout warning light
4WD	4-wheel drive	TURN	Turn signal pilot lamp
		WASH	Low washer fluid warning light

■ Cable Colors

B	BR	CH	DG	G	GY	L	LG	OR	P	PU	R	SB	W	Y
Black	Brown	Charcoal	Dark green	Green	Gray	Blue	Bluish green	Orange	Pink	Purple	Red	Sky blue	White	Yellow

Relays

Note: The part numbers listed in the remarks column identify different manufacturers and the parts affected are interchangeable.

Type	Sketch	Terminal symbol	Identification color	Remarks
1M			Green	Part number 25230-R8100
1M			Blue Green	Part number 25230-C9970 25230-C9980 25230-C9985 25230-C9965 For EGI
1M			Blue	Part number 25230-C9980
1T			Black	Part number 25230-R8201
1T			Black	Part number 25230-C9961 25230-C9971
2M			Brown	Part number 25230-C9920 25230-C9921
2M			Brown	Part number 25230-C9963
1M1B			Gray	Part number 25230-C9915 25230-C9916 25230-C9910
1M1B			Gray	Part number 25230-C9962 25230-C9972

Fuses

The fuse numbers indicated in the following table agree with those shown in the circuit and wiring diagrams.

(1) Passenger compartment

#1	#2	#3	#4/#5	#6	#7	#8	#9	#10	#11	#12	#13
4WD	Electronic parts	Transmission control	Blower motor	Wiper	Engine control	Fuel pump	Audio set	Air conditioner	Mirror, rear wiper	Cigarette lighter	Fog lamp
10A	10A	10A	15A	15A	20A	10A	15A	10A	10A	10A	15A
IGN			ACC			IGN			ACC		
BAT		ST		BAT		IGN		BAT		IGN	
20A		10A		10A		10A		10A		20A	
Antilock brake	Starter signal	Hazard light	Shift lock	Tail light	Air conditioner	Meter	Turn signal light	Electronic parts	Stop light	Interior light	Rear defogger
#14	#15	#16	#17	#18	#19	#20	#21	#22	#23	#24	#25

(2) Engine compartment (Relay box)

	VII	VI	V	IV	III	II	I	
#31	HORN 10A	FL 25A	FL 25A	FL 25A	FL 30A	FL 30A	FL 75A	A/T IND
#32	H/LAMP RH. 15A	RAD FAN	ENG CONT	POWER WDW	ANTI SKID	IGN SW	PTC HEATER 4WD	MAIN
#33	H/LAMP LH. 15A	RAD FAN	ENG CONT	POWER WDW	ANTI SKID	IGN SW	PTC HEATER 4WD	MAIN

H/LAMP	INHIBIT	AIR CON	BLOWER RAD FAN	HORN
--------	---------	---------	-------------------	------

Reading

SERVICE DATA

SECTION **SD**

CONTENTS

F SERVICE DATA	
F1 NEW VEHICLE AND PERIODIC INSPECTION AND MAINTENANCE STANDARDS	SD- 2
1. Engine	SD- 2
2. Chassis	SD- 4
F2 PERIODIC REPLACEMENT PARTS	SD- 8
1. Engine	SD- 8
2. Chassis	SD- 8
F3 LUBRICANTS AND SERVICE POINTS	SD- 9
1. Engine	SD- 9
2. Chassis	SD- 9
F4 SERVICE DATA	SD-10
1. Tightening Torque	SD-10
2. Engine Specifications and Major Data	SD-13

F1 NEW VEHICLE AND PERIODIC INSPECTION AND MAINTENANCE STANDARDS

1. Engine

* Items marked with an asterisk in parentheses do not require periodic inspection. These items are indicated for reference only.

Item		Inspection		RB26DETT
		New engine	Periodic	
Engine	Cylinder head tightening torque N·m (kg-m, ft-lb)	—	○ (for business use)	① 29 (3, 22) ② 108 (11, 80) ③ 0 (0, 0) ④ 29 (3, 22) ⑤ 108 ± 5 (11 ± 0.5, 79.6 ± 3.6)
	Intake and exhaust manifold tightening torque N·m (kg-m, ft-lb)	—	—	Intake: 16 - 21 (1.6 - 2.1, 12 - 15) Exhaust: 18 - 24 (1.8 - 2.4, 13 - 17)
	Valve clearances (when hot) - intake and exhaust mm (in)	—	—	Intake: 0.51 (0.020) Exhaust: 0.44 (0.017) (when cold)
	Standard compression pressure kPa (kg/cm ² , psi)/rpm	—	○	1,177 (12.0, 171)/300
	Limit kPa (kg/cm ² , psi)/rpm	—	○	883 (9.0, 128)/300
	Difference limit among cylinders kPa (kg/cm ² , psi)/rpm	—	○	98 (1.0, 14)
	Idle rpm rpm	—	○	M/T: 950
Emission control systems	CO/HC concentration %/rpm	○	○	Less than 0.1/ greater than 50
	Dashpot "touch" rpm rpm	—	○	—
	TV valve operating temperature °C (°F)	—	—	—
	Catalytic converter tightening torque N·m (kg-m, ft-lb)	—	○	31 - 42 (3.2 - 4.3, 23 - 31)
	Exhaust temperature sensor tightening torque N·m (kg-m, ft-lb)	—	○	25 - 34 (2.5 - 3.5, 18 - 25)
Engine electrical system	Ignition timing °BTDC/rpm	—	○	M/T: 20/950
	Spark plug gap mm (in)	—	○	1.0 - 1.1 (0.039 - 0.043) (Adjustment not required)
	Specific gravity of battery electrolyte 20°C (68°F)	○	○	1.22 - 1.29

F1 NEW VEHICLE AND PERIODIC INSPECTION AND MAINTENANCE STANDARDS

1. Engine (Cont'd)

Cooling system	Coolant pressurization limit		kPa (kg/cm ² , psi)	—	○	98 (1.0, 14)
	Radiator cap relief pressure		kPa (kg/cm ² , psi)	—	○	59 - 98 (0.6 - 1.0, 9 - 14)
	Coolant quantity	Radiator		○	○	Up to lower end of filler opening
		Reservoir tank				Between MIN and MAX
	Fan belt tension [when pressed midpoint with a force of approx. 98 N (10 kg, 22 lb)]	When new	mm (in)	○	○	3.0 - 5.0 (0.118 - 0.197)
		When readjusted		○	○	4.0 - 6.0 (0.157 - 0.236)
		Service limit				7.5 (0.295)
Exhaust system	Tightening torque		N·m (kg·m, ft·lb)	○	○	
	● Heat-shield plate					5 - 7 (0.5 - 0.7, 3.6 - 5.1)
	● Exhaust manifold-to-front tube					45 - 60 (4.6 - 6.1, 33 - 44)
	● Front tube-to-catalytic converter					43 - 55 (4.4 - 5.6, 32 - 41)
	● Catalytic converter-to-center tube					43 - 55 (4.4 - 5.6, 32 - 41)

F1 NEW VEHICLE AND PERIODIC INSPECTION AND MAINTENANCE STANDARDS

2. Chassis

	Item		New vehicle inspection	Periodic inspection	Inspection standards
Clutch	Pedal free play (at clevis)	mm (in)	○	○	5 - 12 (0.20 - 0.47) [1 - 3 (0.04 - 0.12)]
	Pedal-to-floor (when released)	mm (in)		○	81 (3.19)
	Free pedal height	mm (in)	○		171.7 - 181.7 (6.76 - 7.15)
Propeller (drive) shaft	Tightening torque of joints	N-m (kg-m, ft-lb)		○	
	● Front propeller shaft-to-front final drive				24 - 32 (2.4 - 3.3, 17 - 24)
	● Rear propeller shaft-to-rear final drive				64 - 74 (6.5 - 7.5, 47 - 54)
	● Transfer-to-rear propeller shaft				88 - 98 (9.0 - 10, 65 - 72)
	● Center propeller shaft-to-bearing bracket				Bolt: 32 - 38 (3.3 - 3.9, 24 - 28) Nut: 20 - 23 (2.0 - 2.3, 14 - 17)
	● Center flange-to-propeller shaft				64 - 74 (6.5 - 7.5, 47 - 54)
	● Center flange lock nuts				245 - 294 (25 - 30, 181 - 217)
	● Side shaft-to-front drive shaft				16 - 21 (1.6 - 2.1, 12 - 15)
	● Side flange-to-rear drive shaft				83 - 93 (8.5 - 9.5, 61 - 69)
	Propeller shaft runout			○	Less than 6 (0.6, 4.3)
Front suspension and axle	Wheel alignment			○	
	● Toe-in	mm (in)			1 ± 1 (0.04 ± 0.04)
	● Camber	degree			-0°55' ± 45'
	● Caster	degree			RB26DETT: 3°40' ± 45'
	● Kingpin inclination	degree			15°25' ± 45'
	Front wheel bearing play			○	
	● Tightening torque	N-m (kg-m, ft-lb)			235 - 314 (24 - 32, 174 - 231)
	● Axial end play	mm (in)			Less than 0.05 (0.0020)
	Tightening torque of fasteners/ joints	N-m (kg-m, ft-lb)			
	● Suspension member securing nuts				74 - 88 (7.5 - 9.0, 54 - 65)
	● Suspension member-to-lower link ball joint				63 - 78 (6.4 - 8.0, 46 - 58)
	● Lower link ball joint-to-lower link				96 - 120 (9.8 - 12.2, 71 - 88)
	● Lower link-to-suspension lower ball joint				96 - 120 (9.8 - 12.2, 71 - 88)
	● Tension rod-to-suspension member				88 - 108 (9.0 - 11, 65 - 80)
	● Tension rod-to-lower link				108 - 127 (11 - 13, 80 - 94)
	● Ball joint-to-knuckle spindle				72 - 97 (7.3 - 9.9, 53 - 72)
	● Kingpin-to-3rd link				98 - 118 (10 - 12, 72 - 87)
	● Knuckle spindle-to-king pin				147 - 186 (15 - 19, 108 - 137)
	● 3rd link-to-upper link				88 - 108 (9.0 - 11, 65 - 80)
	● Upper link-to-bracket				88 - 108 (9.0 - 11, 65 - 80)
	● Upper link bracket-to-car body				88 - 108 (9.0 - 11, 65 - 80)
	● Spring upper seat lock nuts				18 - 24 (1.8 - 2.4, 13 - 17)
● Shock absorber-to-3rd link				108 - 127 (11 - 13, 80 - 94)	
● Shock absorber-to-car body				39 - 54 (4.0 - 5.5, 29 - 40)	
● 3rd link-to-connecting rod				41 - 47 (4.2 - 4.8, 30 - 35)	
● Connecting rod-to-stabilizer				41 - 47 (4.2 - 4.8, 30 - 35)	
● Stabilizer bracket				39 - 49 (4.0 - 5.0, 29 - 36)	
Rear suspension and axle	Wheel alignment			○	
	● Toe-in	mm (in)			2 ± 2 (0.08 ± 0.08)
	● Camber	degree			RB26DETT: -1°05' ± 30'
	Rear wheel bearing play				
	● Wheel bearing tightening torque	N-m (kg-m, ft-lb)			206 - 275 (21 - 28, 152 - 203)
	● Wheel bearing end play	mm (in)			0 (0)
	Tightening torque	N-m (kg-m, ft-lb)		○	
	● Suspension member securing nuts				98 - 118 (10 - 12, 72 - 87)
● Final drive (on housing side) to suspension member				98 - 118 (10 - 12, 72 - 87)	

F1 NEW VEHICLE AND PERIODIC INSPECTION AND MAINTENANCE STANDARDS

2. Chassis (Cont'd)

	Item	New vehicle inspection	Periodic inspection	Inspection standards																
Rear suspension and axle	● Final drive (on differential case side) to suspension member			98 - 118 (10 - 12, 72 - 87)																
	● Suspension member-to-lower arm			98 - 118 (10 - 12, 72 - 87)																
	● Suspension member-to-upper link (front end)			77 - 98 (7.9 - 10, 57 - 72)																
	● Suspension member-to-upper link (rear end)			77 - 98 (7.9 - 10, 57 - 72)																
	● Suspension member-to-lower link			69 - 88 (7.0 - 9.0, 51 - 65)																
	● Upper link (front end)-to-axle housing			77 - 98 (7.9 - 10, 57 - 72)																
	● Upper link (rear end)-to-axle housing			77 - 98 (7.9 - 10, 57 - 72)																
	● Lower link-to-axle housing			71 - 86 (7.2 - 8.8, 52 - 64)																
	● Lower arm-to-connecting rod			9 - 12 (0.9 - 1.2, 6.5 - 8.7)																
	● Connecting rod-to- stabilizer			9 - 12 (0.9 - 1.2, 6.5 - 8.7)																
	● Stabilizer bracket			43 - 55 (4.4 - 5.6, 32 - 41)																
	● Shock absorber-to- axle housing			88 - 108 (9.0 - 11, 65 - 80)																
	● Shock absorber-to- car body			16 - 19 (1.6 - 1.9, 12 - 14)																
	● Spring upper seat lock nuts			18 - 24 (1.8 - 2.4, 13 - 17)																
● Member stay-to-car body			43 - 55 (4.4 - 5.6, 32 - 41)																	
Road wheels and tires	Air pressure	○	○	(See text)																
	Tire groove wear limit mm (in)		○	1.6 (0.063)																
	Wheel nut tightening torque N-m (kg-m, ft-lb)	○	○	98 - 118 (10 - 12, 72 - 87)																
Foot brake	Pedal play mm (in)	○	○	3 - 11 (0.12 - 0.43)																
	Pedal-to-floor clearance (when depressed) mm (in)		○	Greater than 85 (3.35)																
	Pedal height (From upper surface of floor panel) mm (in)	○		M/T: 172.5 - 182.5 (6.79 - 7.19)																
	Pad wear mm (in)		○	<table border="1" style="width: 100%; border-collapse: collapse;"> <thead> <tr> <th colspan="2" style="text-align: center;">Type</th> <th colspan="2"></th> </tr> <tr> <th style="text-align: center;">Item</th> <th style="text-align: center;">Type</th> <th style="text-align: center;">OPZ25VR</th> <th style="text-align: center;">OPZ11VB</th> </tr> </thead> <tbody> <tr> <td style="text-align: center;">Standard thickness</td> <td></td> <td style="text-align: center;">10 (0.39)</td> <td></td> </tr> <tr> <td style="text-align: center;">Service limit</td> <td></td> <td style="text-align: center;">2.0 (0.079)</td> <td></td> </tr> </tbody> </table>	Type				Item	Type	OPZ25VR	OPZ11VB	Standard thickness		10 (0.39)		Service limit		2.0 (0.079)	
	Type																			
	Item	Type	OPZ25VR	OPZ11VB																
	Standard thickness		10 (0.39)																	
Service limit		2.0 (0.079)																		
Disk wear mm (in)		○	<table border="1" style="width: 100%; border-collapse: collapse;"> <thead> <tr> <th colspan="2" style="text-align: center;">Type</th> <th style="text-align: center;">OPZ25VR</th> <th style="text-align: center;">OPZ11VB</th> </tr> <tr> <th style="text-align: center;">Item</th> <th style="text-align: center;">Type</th> <th></th> <th></th> </tr> </thead> <tbody> <tr> <td style="text-align: center;">Standard thickness</td> <td></td> <td style="text-align: center;">32 (1.26)</td> <td style="text-align: center;">18 (0.71)</td> </tr> <tr> <td style="text-align: center;">Service limit</td> <td></td> <td style="text-align: center;">30 (1.18)</td> <td style="text-align: center;">16 (0.63)</td> </tr> </tbody> </table>	Type		OPZ25VR	OPZ11VB	Item	Type			Standard thickness		32 (1.26)	18 (0.71)	Service limit		30 (1.18)	16 (0.63)	
Type		OPZ25VR	OPZ11VB																	
Item	Type																			
Standard thickness		32 (1.26)	18 (0.71)																	
Service limit		30 (1.18)	16 (0.63)																	
Brake hose and tube installation			○																	
● Flare nut tightening torque N-m (kg-m, ft-lb)			15 - 18 (1.5 - 1.8, 11 - 13)																	
Parking brake	Brake drum wear mm (in)		○	<table border="1" style="width: 100%; border-collapse: collapse;"> <thead> <tr> <th colspan="2" style="text-align: center;">Type</th> <th style="text-align: center;">LT23C</th> <th style="text-align: center;">DS17HD</th> </tr> <tr> <th style="text-align: center;">Item</th> <th style="text-align: center;">Type</th> <th></th> <th></th> </tr> </thead> <tbody> <tr> <td style="text-align: center;">Standard I.D.</td> <td></td> <td style="text-align: center;">228.6 (9)</td> <td style="text-align: center;">172 (6.77)</td> </tr> <tr> <td style="text-align: center;">I.D. service limit</td> <td></td> <td style="text-align: center;">230 (9.06)</td> <td style="text-align: center;">173 (6.81)</td> </tr> </tbody> </table>	Type		LT23C	DS17HD	Item	Type			Standard I.D.		228.6 (9)	172 (6.77)	I.D. service limit		230 (9.06)	173 (6.81)
	Type		LT23C	DS17HD																
	Item	Type																		
Standard I.D.		228.6 (9)	172 (6.77)																	
I.D. service limit		230 (9.06)	173 (6.81)																	
Brake lining wear mm (in)		○	<table border="1" style="width: 100%; border-collapse: collapse;"> <thead> <tr> <th colspan="2" style="text-align: center;">Type</th> <th style="text-align: center;">LT23C</th> <th style="text-align: center;">DS17HD</th> </tr> <tr> <th style="text-align: center;">Item</th> <th style="text-align: center;">Type</th> <th></th> <th></th> </tr> </thead> <tbody> <tr> <td style="text-align: center;">Standard thickness</td> <td></td> <td style="text-align: center;">4.5 (0.177)</td> <td style="text-align: center;">3.0 (0.118)</td> </tr> <tr> <td style="text-align: center;">Service limit</td> <td></td> <td style="text-align: center;">1.5 (0.059)</td> <td style="text-align: center;">1.5 (0.059)</td> </tr> </tbody> </table>	Type		LT23C	DS17HD	Item	Type			Standard thickness		4.5 (0.177)	3.0 (0.118)	Service limit		1.5 (0.059)	1.5 (0.059)	
Type		LT23C	DS17HD																	
Item	Type																			
Standard thickness		4.5 (0.177)	3.0 (0.118)																	
Service limit		1.5 (0.059)	1.5 (0.059)																	
Lever pull, with a force of 196 N (20 kg, 44 lb) Center lever type: (notch)		○	○	6 - 8																

F1 NEW VEHICLE AND PERIODIC INSPECTION AND MAINTENANCE STANDARDS

2. Chassis (Cont'd)

Steering system	Steering wheel tightening torque N·m (kg-m, ft-lb)	○	○	29 - 39 (3.0 - 4.0, 22 - 29)						
	Steering wheel play mm (in)	○	○	0 - 35 (0 - 1.38)						
	Steering gear tightening torque N·m (kg-m, ft-lb)		○							
	● Steering gear securing bolts			88 - 108 (9.0 - 11, 65 - 80)						
	● Ball joint-to-knuckle spindle			29 - 39 (3.0 - 4.0, 22 - 29)						
	Rod and arm tightening torque N·m (kg-m, ft-lb)		○							
	● Lower joint securing bolts			24 - 29 (2.4 - 3.0, 17 - 22)						
	● Steering gear-to-inner socket			78 - 98 (8.0 - 10, 58 - 72)						
● Side rod lock nuts			78 - 98 (8.0 - 10, 58 - 72)							
Power steering belt tension (deflection when pressed midpoint of belt) mm (in)	○	○								
	<table border="1" style="width: 100%; border-collapse: collapse;"> <thead> <tr> <th style="text-align: left;">Deflection Engine</th> <th style="text-align: center;">When new</th> <th style="text-align: center;">When read-justed</th> <th style="text-align: center;">Service limit</th> </tr> </thead> <tbody> <tr> <td>RB-series engine</td> <td style="text-align: center;">8 - 10 (0.31 - 0.39)</td> <td style="text-align: center;">9 - 11 (0.36 - 0.43)</td> <td style="text-align: center;">15 (0.59)</td> </tr> </tbody> </table>			Deflection Engine	When new	When read-justed	Service limit	RB-series engine	8 - 10 (0.31 - 0.39)	9 - 11 (0.36 - 0.43)
Deflection Engine	When new	When read-justed	Service limit							
RB-series engine	8 - 10 (0.31 - 0.39)	9 - 11 (0.36 - 0.43)	15 (0.59)							
Steering system	Power steering system tightening torque N·m (kg-m, ft-lb)		○							
	● Oil pump securing bolts			31 - 42 (3.2 - 4.3, 23 - 31)						
	● Oil pump pulley securing nuts			16 - 21 (1.6 - 2.1, 12 - 15) (Adjustment side)						
	● Reservoir tank securing bolts			54 - 68 (5.5 - 6.9, 40 - 50)						
	● Low pressure oil tube-to-steering gear			3 - 4 (0.3 - 0.4, 2.2 - 2.9)						
	● High pressure oil tube-to-steering gear			27 - 39 (2.8 - 4.0, 20 - 29)						
	● High pressure oil tube-to-oil pump			15 - 25 (1.5 - 2.5, 11 - 18)						
	● Right tube clamp bracket-to-car body			49 - 69 (5.0 - 7.0, 36 - 51)						
● Front tube clamp bracket-to-car body			3 - 4 (0.3 - 0.4, 2.2 - 2.9)							
● Cylinder tube-to-gear housing			[8 - 11 (0.8 - 1.1, 5.8 - 8.0)]							
SUPER HICAS	● Tightening torque of power cylinder fasteners/joints N·m (kg-m, ft-lb)		○	20 - 26 (2.0 - 2.7, 14 - 20)						
	● Power cylinder securing bolts			84 - 108 (8.6 - 11, 62 - 80)						
	● Outer link rod lock nuts			37 - 46 (3.8 - 4.7, 27 - 34)						
	● Power cylinder outer ring-to-axle housing			45 - 60 (4.6 - 6.1, 33 - 44)						
	● Stroke stopper lock nuts			49 - 69 (5.0 - 7.0, 36 - 51)						
	Tightening torque of power steering system fasteners/joints N·m (kg-m, ft-lb)		○							
	● Oil pump securing bolts			31 - 42 (3.2 - 4.3, 23 - 31)						
	● Reservoir tank securing bolts			16 - 21 (1.6 - 2.1, 12 - 15) (Adjustment side)						
	● HICAS solenoid valve union bolts (on reservoir tank side)			3 - 4 (0.3 - 0.4, 2.2 - 2.9)						
	● HICAS solenoid valve union bolts (on oil pump side)			49 - 69 (5.0 - 7.0, 36 - 51)						
	● HICAS solenoid valve (on high and low pressure sides)			49 - 69 (5.0 - 7.0, 36 - 51)						
	● Solenoid valve-to-bracket			39 - 51 (4.0 - 5.2, 29 - 38)						
	Oil pump-to-steering gear (on high pressure side of power steering)			18 - 24 (1.8 - 2.4, 13 - 17)						
	Steering gear-to-reservoir tank (on low pressure side of power steering)			15 - 25 (1.5 - 2.5, 11 - 18)						
	HICAS solenoid valve-to-oil pump			27 - 39 (2.8 - 4.0, 20 - 29)						
	HICAS solenoid valve-to-reservoir tank			49 - 69 (5.0 - 7.0, 36 - 51)						
Power cylinder tube			49 - 69 (5.0 - 7.0, 36 - 51)							
Cylinder tube clamp			39 - 49 (4.0 - 5.0, 29 - 36)							
Hose clamp			4.4 - 5.8 (0.45 - 0.59, 3.3 - 4.3)							
● Cutoff valve bracket securing bolts			8 - 11 (0.8 - 1.1, 5.8 - 8.0)							
● Cutoff valve-to-power cylinder union bolts			13 - 16 (1.3 - 1.6, 9 - 12) (front)							
● Rear central piping-to-cutoff valve			4.4 - 5.8 (0.45 - 0.59, 3.3 - 4.3) (rear)							
			49 - 69 (5.0 - 7.0, 36 - 51)							
			39 - 49 (4.0 - 5.0, 29 - 36)							

F2 PERIODIC REPLACEMENT PARTS AND MAINTENANCE STANDARDS

1. Engine

Periodic replacement parts	Replacement interval
Air cleaner element	Every 60,000 km (36,000 miles)
Timing belt	Every 100,000 km (60,000 miles)
Engine oil	Every 5,000 km (3,000 miles)
Oil filter	Every 10,000 km (6,000 miles) or yearly
Fuel filter	Every 100,000 km (60,000 miles)
Fuel hose (except for type D)	First time: After 5 years Thereafter: Every 4 years
	Every 2 years (inside engine compartment) Every 4 years (outside engine compartment)
LLC	First time: After 3 years Thereafter: Every 2 years
	Every 2 years
Catalyst	Yearly
Spark plug	Every 100,000 km (60,000 miles)

2. Chassis

Periodic replacement parts	Replacement interval
Brake system	First time: After 5 years Thereafter: Every 4 years
	Every 4 years
	First time: After 3 years Thereafter: Every 2 years
	Yearly
	First time: After 3 years Thereafter: Every 2 years
	Every 2 years
Wheel cylinder (including caliper) cup and dust seal	First time: After 5 years Thereafter: Every 4 years
	Every 2 years
Suspension ball joint grease	Every 120,000 km (72,000 miles) or every 4 years
Manual transmission fluid	Every 100,000 km (60,000 miles) or every 2 years
Differential fluid	Every 100,000 km (60,000 miles) or every 2 years

F3 LUBRICANTS AND SERVICE POINTS AND MAINTENANCE STANDARDS

1. Engine

Inspection and service points	Lubricant type	Remarks
Throttle chamber linkage	Nissan MP No. 2 Grease	Apply during disassembly.
Accelerator linkage	NISSAN MP No. 2 Grease or Chassis Grease	Apply during disassembly.

2. Chassis

Inspection and service points	Lubricant type	Remarks
Clutch disc spline	Nissan Clutch Grease (KRI06-00010)	
Main drive shaft spline		
Clutch release mechanism	Nissan Clutch Sleeve Grease (KRI06-00010)	
Manual transmission	Nissan Gear Oil MP-G Special GL-475W-90	Gear Oil GL-4 MP-G 80W-90 (for extremely cold areas)
Automatic transmission	Nissanmatic Fluid D	
Transfer	Nissanmatic Fluid D	
ETS hydraulic unit	Nissan Power Steering Fluid Special	
Propeller shaft center bearing washer	Nissan Clutch Molybdenum Grease	
Propeller shaft universal joint	Nissan MP Special Grease No. 2	
Front final drive	F160	Nissan Gear Oil Hypoid GL-5 85W-90
Rear final drive	R200 (Mechanical LSD)	Nissan Gear Oil Hypoid LSD GL-5 80W-90
Drive shaft	Fixed joint	6080 grease (Kyodo brand)
	Sliding joint	
Front and rear wheel bearings	Nissan MP Special Grease No. 2	
Brake (Master cylinder)	Nissan Brake Fluid No. 2500 (NR-3)	
Cylinder rubber parts (Brake system)	Nissan Rubber Lubricant (KRE12-00030)	
Disc brake	Nissan Disc Brake Grease (KRF16-00005)	
Brake pedal fulcrum pin or shaft	Nissan MP Special Grease No. 2	
Parking brake cable	Nissan MP Special Grease No. 2	
Power steering	Nissan Power Steering Fluid	

F4 SERVICE DATA AND MAINTENANCE STANDARDS

1. Tightening Torque

1-1 ENGINE COMPONENTS

	Components	Tightening torque		
		RB26DETT		
		N-m	kg-m	ft-lb
Engine body	Main bearing cap bolts	46 - 52	4.7 - 5.3	34 - 38
	Connecting bolts and nuts	① 14 - 16	1.4 - 1.6 ② (60° - 65°)	10 - 12
	Flywheel bolts (M/T models)	142 - 152	14.5 - 15.5	105 - 112
	Drive plate bolts (A/T models)	—	—	—
	Crank pulley bolts	446 - 466	45.5 - 47.5	329 - 344
	Oil strainer securing bolt	16 - 21	1.6 - 2.1	12 - 15
	Rear oil seal retainer securing bolts	6.3 - 8.3	0.64 - 0.85	4.6 - 6.1
	Oil pump securing bolts	10 - 12	1.0 - 1.2	7 - 9
	Water pump securing bolts	M6: 7 - 8	0.7 - 0.8	5.1 - 5.8
		M8: 16 - 21	1.6 - 2.1	12 - 15
		M10: 30 - 40	3.1 - 4.1	22 - 30
	Cam pulley securing bolts	14 - 19	1.4 - 1.9	10 - 14
	Camshaft retainer securing bolts	9.0 - 11.8	0.92 - 1.2	6.7 - 8.7
	Rocker cover screws	2 - 4	0.2 - 0.4	1.4 - 2.9
	Timing belt cover	3 - 5	0.3 - 0.5	2.2 - 3.6
	Belt tensioner securing nut	43 - 58	4.4 - 5.9	32 - 43
	Water drain plug	34 - 44	3.5 - 4.5	25 - 33
	Blow-by control valve	29 - 39	3.0 - 4.0	22 - 29
	Oil pan drain plug	29 - 39	3.0 - 4.0	22 - 29
	Oil pan securing bolts	M6: 6.3 - 8.3	0.64 - 0.85	4.6 - 6.1
		M10: 31 - 42	3.2 - 4.3	23 - 31
	Oil filter stud: (cylinder block side)	29 - 39	3.0 - 4.0	22 - 29
		(oil filter side)	15 - 21	1.5 - 2.1
Cylinder head bolts	M12: ① 29	3	22	
	② 108	11	80	
	③ 0 (Lower)	0	0	
	④ 29	3	22	
	⑤ (85° - 90°) or 103 - 113	(85° - 90°) or 10.5 - 11.5	(85° - 90°) or 76 - 83	
	M6: 9.0 - 11.8	0.92 - 1.2	6.7 - 8.7	
Intake and exhaust systems	Intake manifold securing bolts	16 - 21	1.6 - 2.1	12 - 15
	Intake manifold securing nuts	16 - 21	1.6 - 2.1	12 - 15
	Collector bolts	16 - 21	1.6 - 2.1	12 - 15
	Exhaust manifold securing nuts	18 - 24	1.8 - 2.4	13 - 17
	O ₂ sensor securing nuts	18 - 24	1.8 - 2.4	13 - 17
	Throttle chamber securing bolts	16 - 21	1.6 - 2.1	12 - 15
	Throttle valve switch	2.0 - 2.4	0.2 - 0.24	1.4 - 1.7
	Intake manifold support bracket securing bolts	—	—	—
	Turbocharger inlet nuts	23 - 29	2.3 - 3.0	17 - 22
	Turbocharger outlet nuts	23 - 29	2.3 - 3.0	17 - 22
	Water bypass tube	15 - 20	1.5 - 2.0	11 - 14

F4 SERVICE DATA AND MAINTENANCE STANDARDS

1. Tightening Torque (Cont'd)

	Components	Tightening torque		
		RB26DETT		
		N·m	kg-m	ft-lb
Intake and exhaust systems	Turbocharger oil tube (turbo side)	17 - 21	1.7 - 2.1	12 - 15
	Turbocharger oil tube (cylinder block side)	15 - 20	1.5 - 2.0	11 - 14
	Turbocharger water tube (turbo side)	20 - 31	2 - 3.2	14 - 23
	Turbocharger water tube (cylinder block side)	20 - 31	2 - 3.2	14 - 23
Sensors and others	Crank angle sensor	4 - 5	0.4 - 0.5	2.9 - 3.6
	Crank angle sensor bracket	16 - 21	1.6 - 2.1	12 - 15
	Spark plugs	20 - 29	2.0 - 3.0	14 - 22
	Engine temperature sensor	20 - 29	2.0 - 3.0	14 - 22
	Thermal transmitter	15 - 20	1.5 - 2.0	11 - 14
	Knock sensor	21 - 26	2.1 - 2.7	15 - 20
	O ₂ sensor	18 - 24	1.8 - 2.4	13 - 17
	Exhaust temperature sensor	25 - 34	2.5 - 3.5	18 - 25
	Injector holder securing bolts	4 - 5	0.4 - 0.5	2.9 - 3.6
	Air regulator securing bolts	8.4 - 10.8	0.86 - 1.1	6.2 - 8.0
	IAA unit securing bolts	—	—	—
	Water outlet securing bolts	16 - 21	1.6 - 2.1	12 - 15
	Water inlet securing bolts	—	—	—
	Alternator securing-adjusting bolts	9.1 - 11.8	0.93 - 1.2	6.7 - 8.7
	Alternator securing nuts	45 - 60	4.6 - 6.1	33 - 44
	Starter motor securing bolts	30 - 40	3.1 - 4.1	22 - 30
	Compressor securing bolts	37 - 50	3.8 - 5.1	27 - 37
	Compressor bracket securing bolts	37 - 50	3.8 - 5.1	27 - 37
Power steering bracket securing bolts	37 - 50	3.8 - 5.1	27 - 37	
Power steering adjustment bar securing bolts	14 - 19	1.4 - 1.9	10 - 14	
Ignition coil bracket securing bolts	9.1 - 11.8	0.93 - 1.2	6.7 - 8.7	

**F4 SERVICE DATA
AND MAINTENANCE STANDARDS**

1. Tightening Torque (Cont'd)

1-2 MANUAL TRANSMISSION COMPONENTS

Unit: N-m (kg-m, ft-lb)

Components	Type	FS5R30A
Rear extension securing bolts		31 - 42 (3.2 - 4.3, 23 - 31)
Front cover securing bolts		16 - 21 (1.6 - 2.1, 12 - 15)
Check ball plug		19 - 25 (1.9 - 2.6, 14 - 19)
Filler plug		25 - 34 (2.5 - 3.5, 18 - 25)
Drain plug		25 - 34 (2.5 - 3.5, 18 - 25)
Reverse lamp switch		20 - 29 (2.0 - 3.0, 14 - 22)
Neutral switch		20 - 29 (2.0 - 3.0, 14 - 22)
Control housing-to-rear extension		
M8 bolts		16 - 21 (1.6 - 2.1, 12 - 15)
Select check plug		20 - 29 (2.0 - 3.0, 14 - 22)
Bearing retainer-to- adapter plate		16 - 21 (1.6 - 2.1, 12 - 15)
5-R fork rod securing bolts		16 - 21 (1.6 - 2.1, 12 - 15)
Reverse fork securing bolts		19 - 25 (1.9 - 2.6, 14 - 19)
Rear guide plate securing bolts		6.3 - 8.3 (0.64 - 0.85, 4.6 - 6.1)

**F4 SERVICE DATA
AND MAINTENANCE STANDARDS**

1. Tightening Torque (Cont'd)

1-3 F160 FINAL DRIVE

Unit: N·m (kg-m, ft-lb)

Components	Tightening torque
Drive gear securing bolts	93 - 113 (9.5 - 11.5, 69 - 83)
Drive pinion securing bolts	167 - 196 (17 - 20, 123 - 145)
Side retainer securing bolts	16 - 19 (1.6 - 1.9, 12 - 14)
Side shaft securing bolts	16 - 21 (1.6 - 2.1, 12 - 15)
Carrier cover securing bolts	29 - 37 (3.0 - 3.8, 22 - 27)

1-4 R200 FINAL DRIVE

Unit: N·m (kg-m, ft-lb)

Components	Tightening torque
Drive gear securing bolts	177 - 196 (18.0 - 20.0, 130 - 145)
Bearing cap securing bolt	88 - 98 (9 - 10, 65 - 72)
Drive pinion securing nut	186 - 294 (19 - 30, 137 - 217)
Carrier case cover securing nuts	39 - 49 (4 - 5, 29 - 36)
Drain plug	59 - 98 (6 - 10, 43 - 72)
Filler plug	59 - 98 (6 - 10, 43 - 72)

F4 SERVICE DATA AND MAINTENANCE STANDARDS

2. Engine Specifications and Major Data

	Item	RB26DETT
Cylinder block	Bore diameter	mm (in) 86.000 - 86.030 (3.3858 - 3.3870)
	Wear limit	mm (in) 0.2 (0.008)
	Out-of-roundness	mm (in) 0.015 (0.0006)
	Taper	mm (in) 0.010 (0.0004)
	Warpage limit of cylinder block upper surface	mm (in) 0.1 (0.004)
Cylinder head	Ream limit of valve guide holes Intake	mm (in) 10.46 - 10.67 (0.4118 - 0.4201)
	Exhaust	11.46 - 11.47 (0.4512 - 0.4516)
	Ream limit of inside diameter Intake	mm (in) 6.000 - 6.018 (0.2362 - 0.2369)
	Exhaust	7.000 - 7.018 (0.2756 - 0.2763)
	Service limit of valve guide-to-valve stem clearance	mm (in) 0.080 - 0.113 (0.0031 - 0.0044)
	Warpage limit of lower surface	mm (in) 0.2 (0.008)
	Cylinder head gasket thickness	mm (in) 1.2 (0.047)
Piston rings	Piston type	Thermal flow
	Standard outside diameter of piston skirt	mm (in) 85.955 - 85.985 (3.3840 - 3.3852)
	Piston skirt-to-cylinder clearance	mm (in) 0.035 - 0.055 (0.0014 - 0.0022)
	Standard piston pin outside diameter	mm (in) 20.989 - 21.001 (0.8263 - 0.8268)
	Piston pin-to-piston pin bore clearance	mm (in) 0 to -0.004 (0 to -0.0002)
	Piston ring end clearance Top	mm (in) 0.24 - 0.34 (0.0094 - 0.0134)
	Second	0.42 - 0.57 (0.0165 - 0.0224)
	Oil	0.20 - 0.60 (0.0079 - 0.0236)
	Piston ring side clearance Top	mm (in) 0.040 - 0.075 (0.0016 - 0.0030)
	Second	0.030 - 0.065 (0.0012 - 0.0026)
Oil	0.065 - 0.135 (0.0026 - 0.0053)	
Connecting rod	Center-to-center distance of large and small end bores	mm (in) 121.45 - 121.55 (4.7815 - 4.7854)
	Large end bore diameter	mm (in) 47.989 - 48.007 (1.8893 - 1.8900)
	Bend and twist limit [per 100 mm (3.94 in) in length]	mm (in) Bend 0.15 (0.0059) and Twist 0.3 (0.012)
	Large end side clearance	mm (in) 0.2 - 0.3 (0.008 - 0.012)
	Large end oil clearance	mm (in) 0.020 - 0.040 (0.0008 - 0.0016)
	Piston pin-to-connecting rod small end bore clearance	mm (in) 0.005 - 0.017 (0.0002 - 0.0007)
Crankshaft	Standard journal diameter	mm (in) 54.951 - 54.975 (2.1634 - 2.1644)
	Standard pin diameter	mm (in) 47.961 - 47.974 (1.8882 - 1.8887)
	Out-of-roundness and taper of journal	mm (in) Less than 0.005 (0.0002)
	Out-of-roundness and taper of pin	mm (in) Less than 0.005 (0.0002)
	Main bearing oil clearance	mm (in) 0.028 - 0.047 (0.0011 - 0.0019) (selective fit)
	Standard thrust clearance	mm (in) 0.2 - 0.3 (0.008 - 0.012)
Camshaft	Cam nose height (oblong diameter) Intake	mm (in) 40.580 - 40.583 (1.5976 - 1.5978)
	Exhaust	40.280 - 40.283 (1.5858 - 1.5859)
	Bend limit	mm (in) 0.05 (0.0020)
	Standard cam bracket inside diameter	mm (in) No. 1 - No. 7 28.000 - 28.021 (1.1024 - 1.1032)
	Standard cam journal outside diameter	mm (in) No. 1 - No. 7 27.935 - 27.955 (1.0998 - 1.1006)

**F4 SERVICE DATA
AND MAINTENANCE STANDARDS**

2. Engine Specifications and Major Data (Cont'd)

	Item	RB26DETT
Camshaft	Standard bracket-to-journal clearance mm (in)	No. 1 - No. 7 0.045 - 0.086 (0.0018 - 0.0034)
	Standard end play mm (in)	0.030 - 0.080 (0.0012 - 0.0031)
Valves and valve springs	Standard valve lifter outside diameter mm (in)	30.955 - 30.965 (1.2187 - 1.2191)
	Lifter guide bore diameter mm (in)	31.000 - 31.020 (1.2205 - 1.2213)
	Standard lifter-to-lifter guide clearance mm (in)	0.035 - 0.065 (0.0014 - 0.0026)
	Valve face outside diameter mm (in)	34.5 - 34.7 (1.358 - 1.366) 30.0 - 30.2 (1.181 - 1.189)
	Valve stem outside diameter mm (in)	5.980 - 5.965 (0.2354 - 0.2348) 6.920 - 6.905 (0.2724 - 0.2718)
	Valve spring squareness limit mm (in)	1.8 (0.071) (Single spring)
	Standard valve spring free length mm (in)	46.54 (1.8323) (Single spring)
	Standard as-installed load of valve spring N (kg, lb)	235.4 (24.0, 52.9) [35 mm (1.38 in)] (Single spring)
Flywheel	Runout limit (on clutch disc mating surface) (M/T models) mm (in)	1.0 (0.039)

FIG. NO. 1 C-1 4WD vehicles (RB20DET/RB26DETT equipped models)

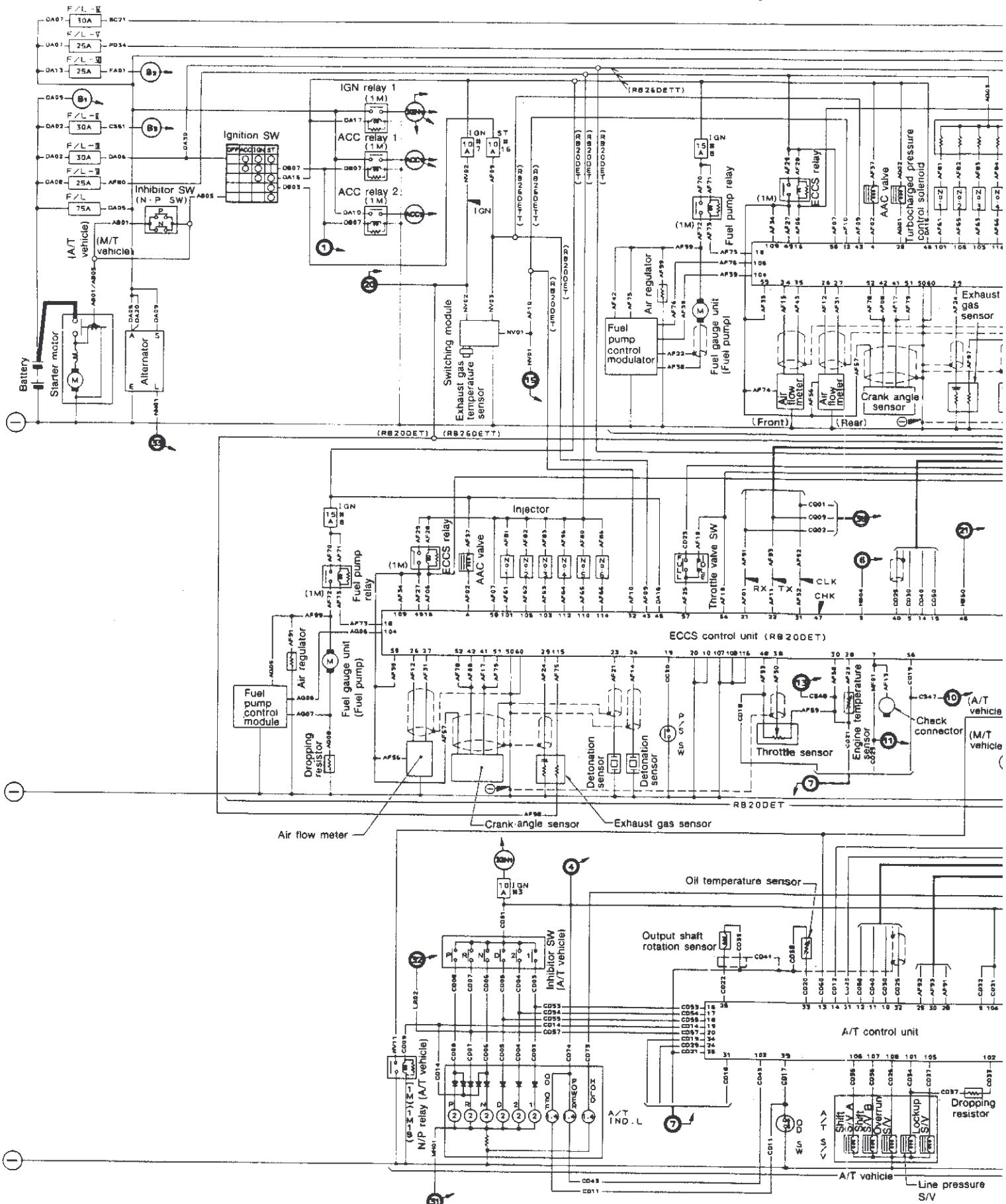

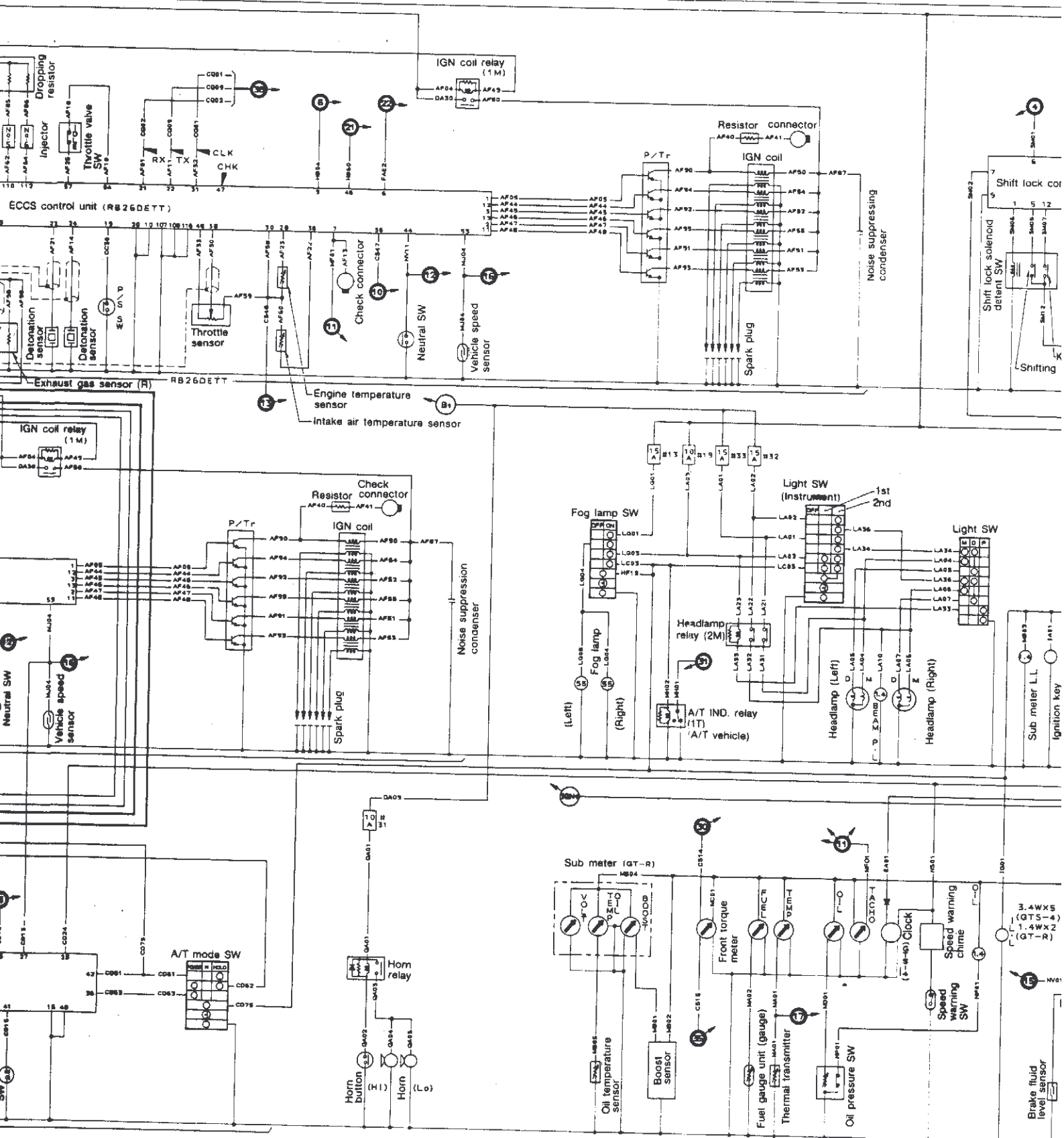

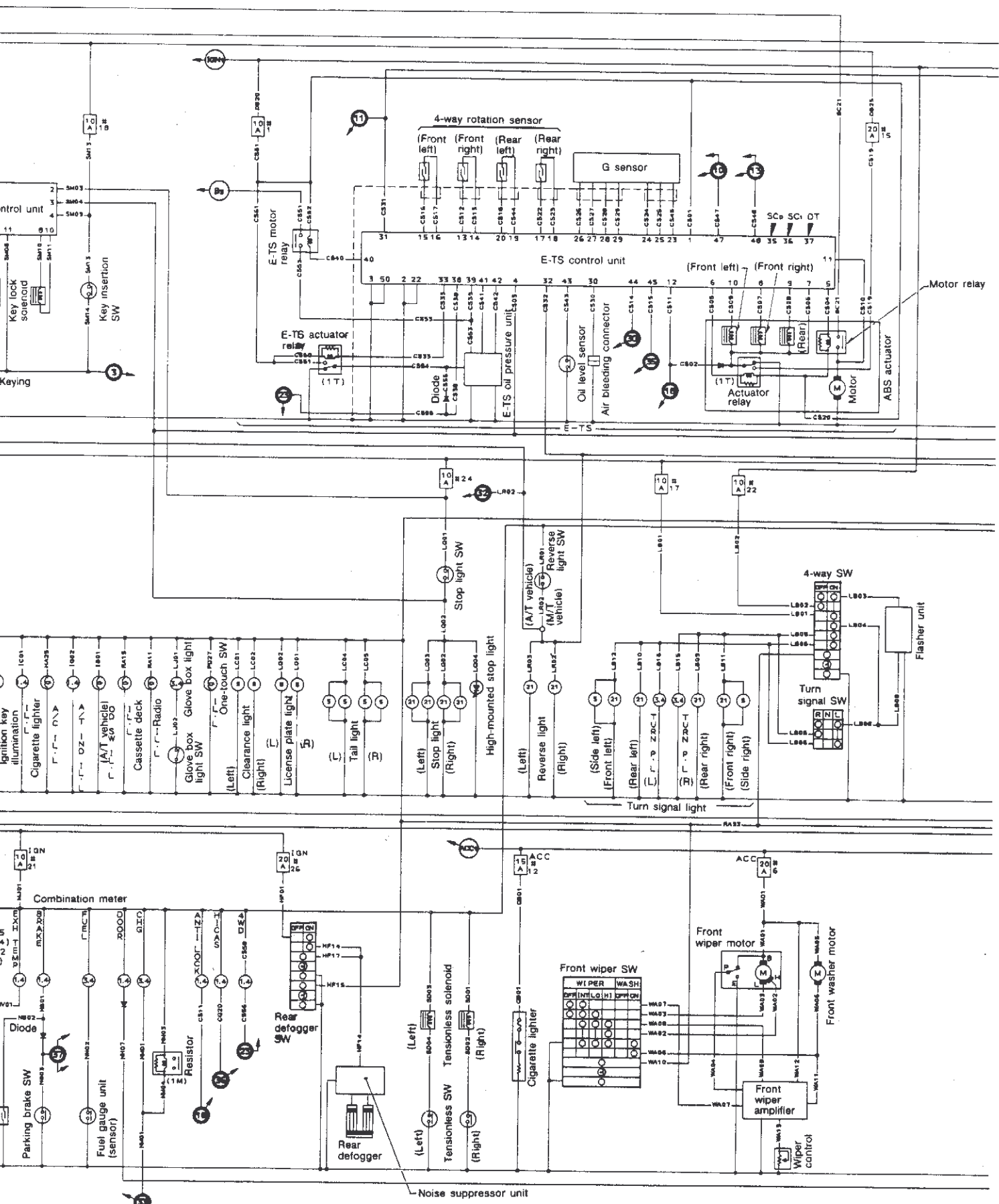

Cont'd Fig. No. 1 C-1 4WD Vehicles (RB20DET/RB26DETT equipped models)

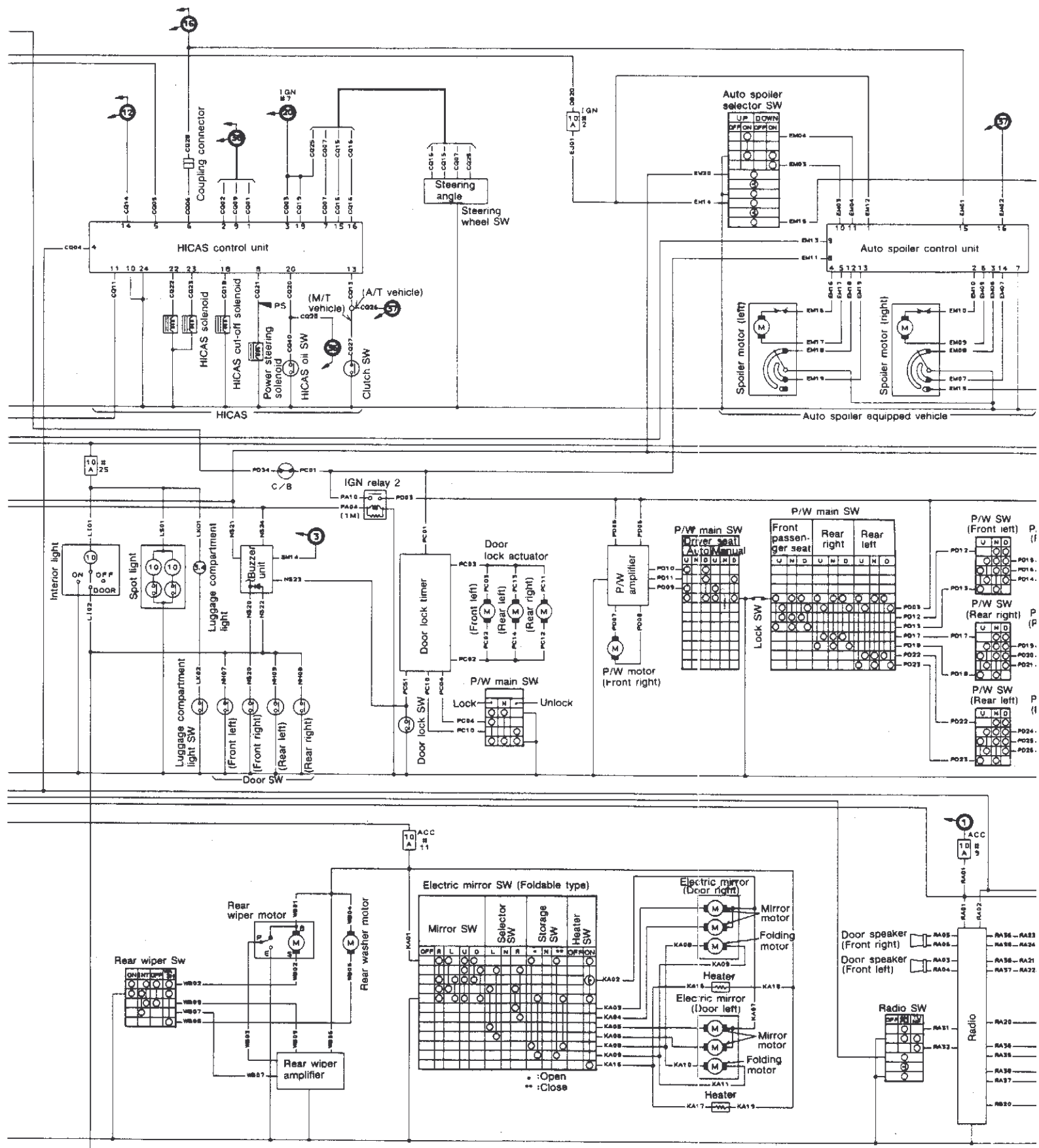

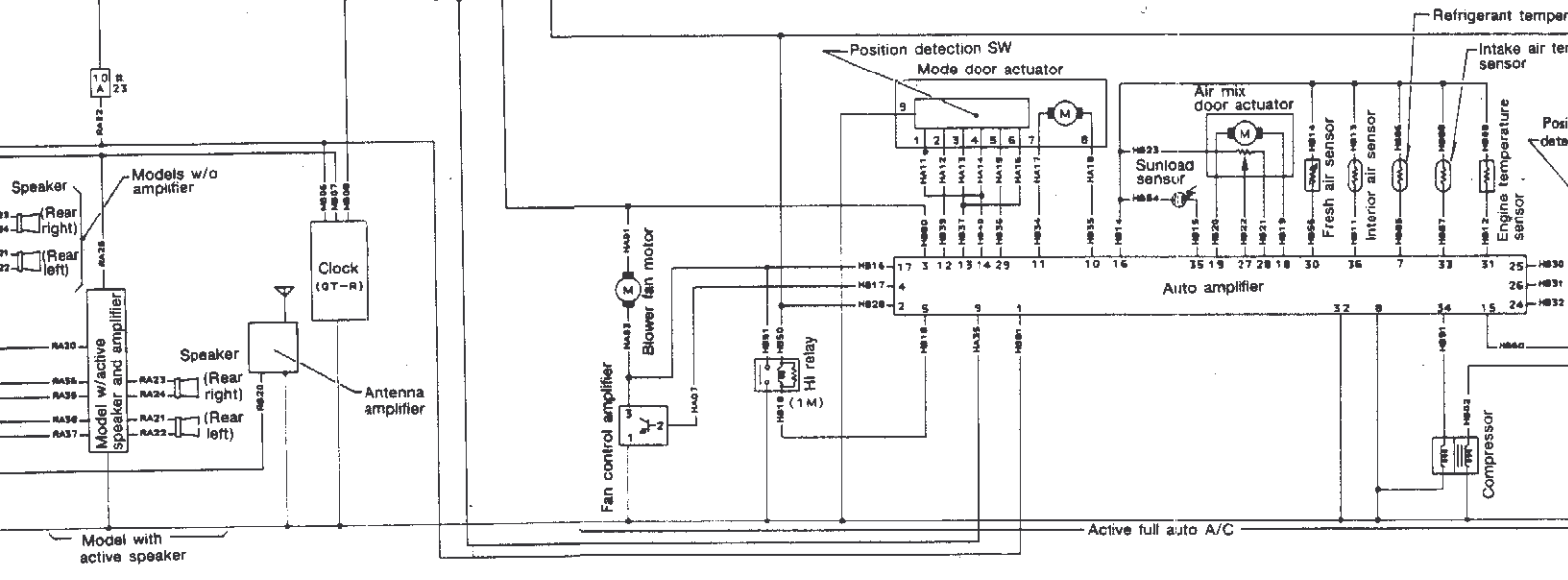
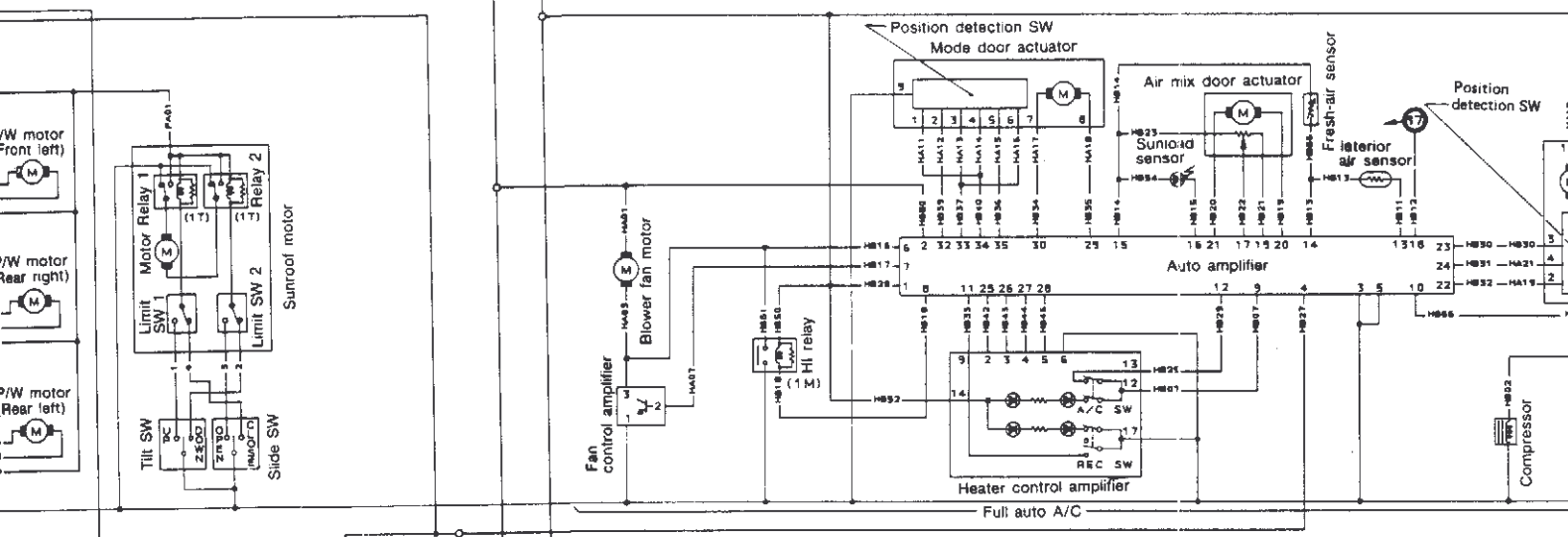
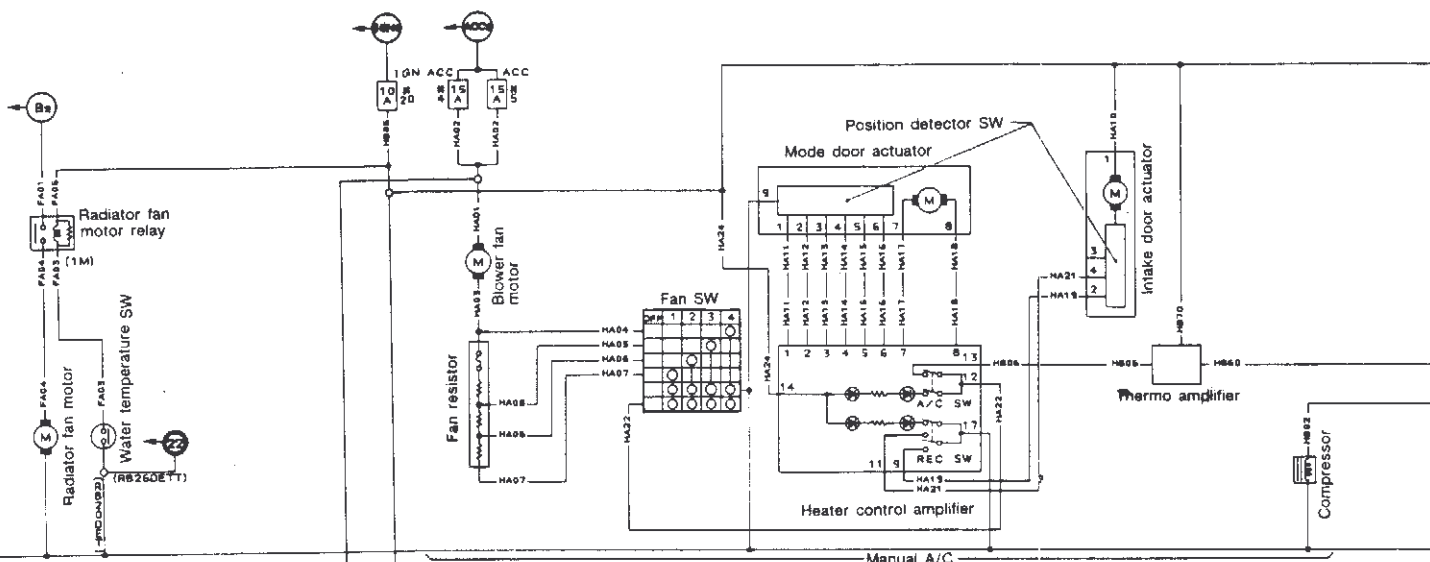

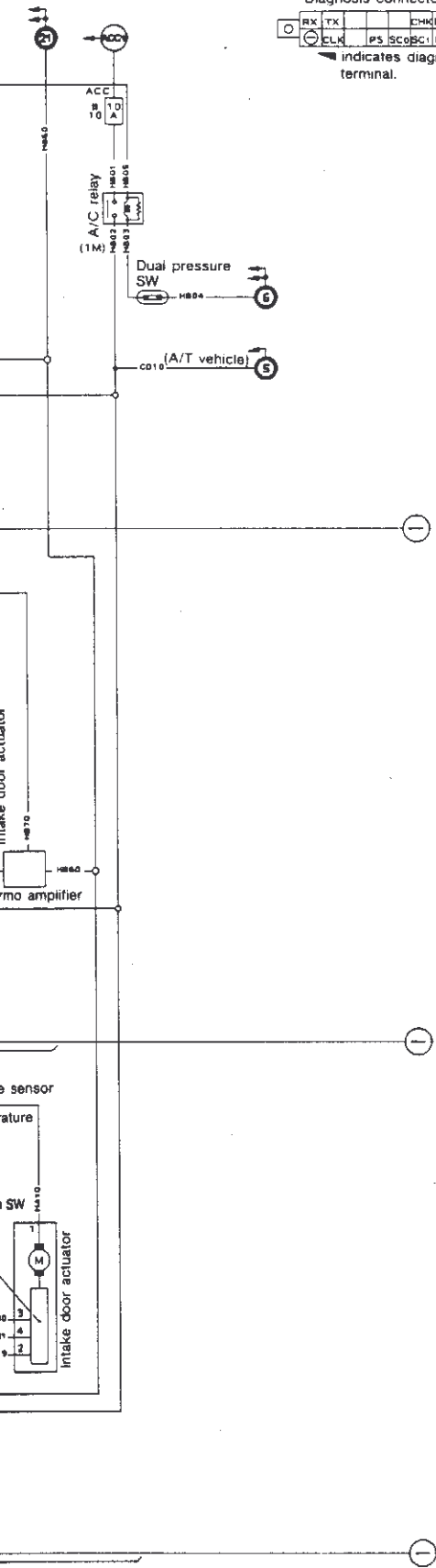
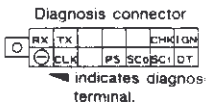
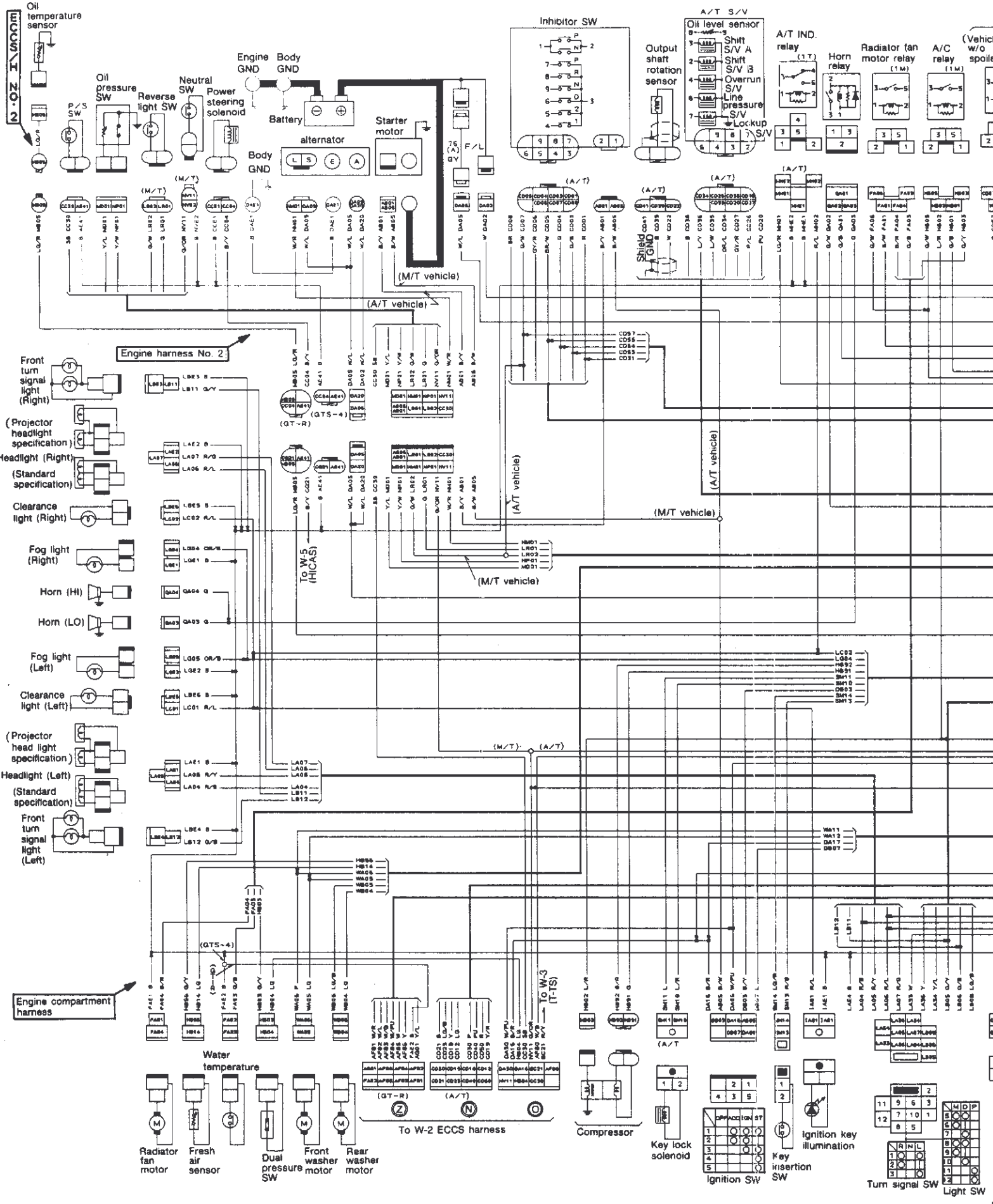
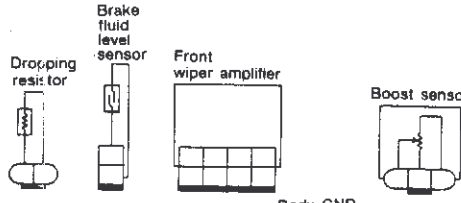
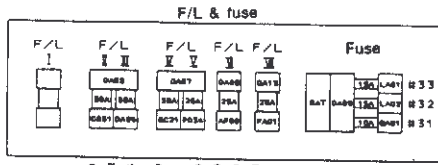
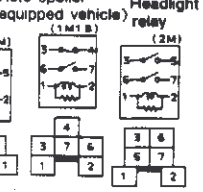

Fig. No. 2 W-1 4WD VEHICLE (RB20DET/RB26DETT EQUIPPED MODELS)



P relay
Auto spoiler
equipped vehicle



To W-3 (E-TS)
To W-5 (HICAS)

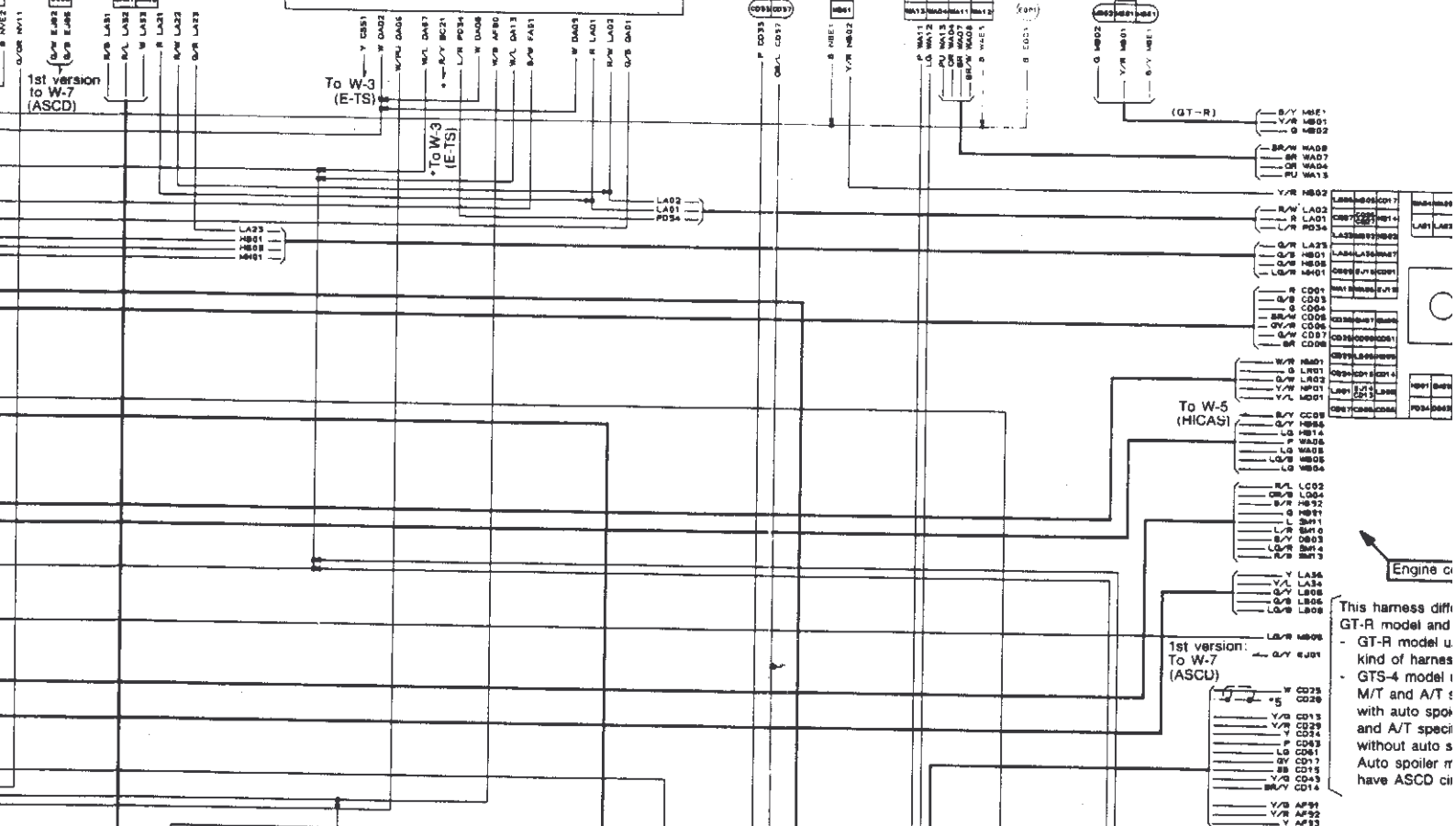

Engine of
This harness diff
GT-R model and
- GT-R model u
kind of harness
- GTS-4 model
M/T and A/T s
with auto spok
and A/T speci
without auto s
Auto spoiler m
have ASCD cir

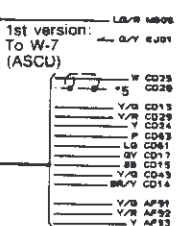

*5: Grounded shield

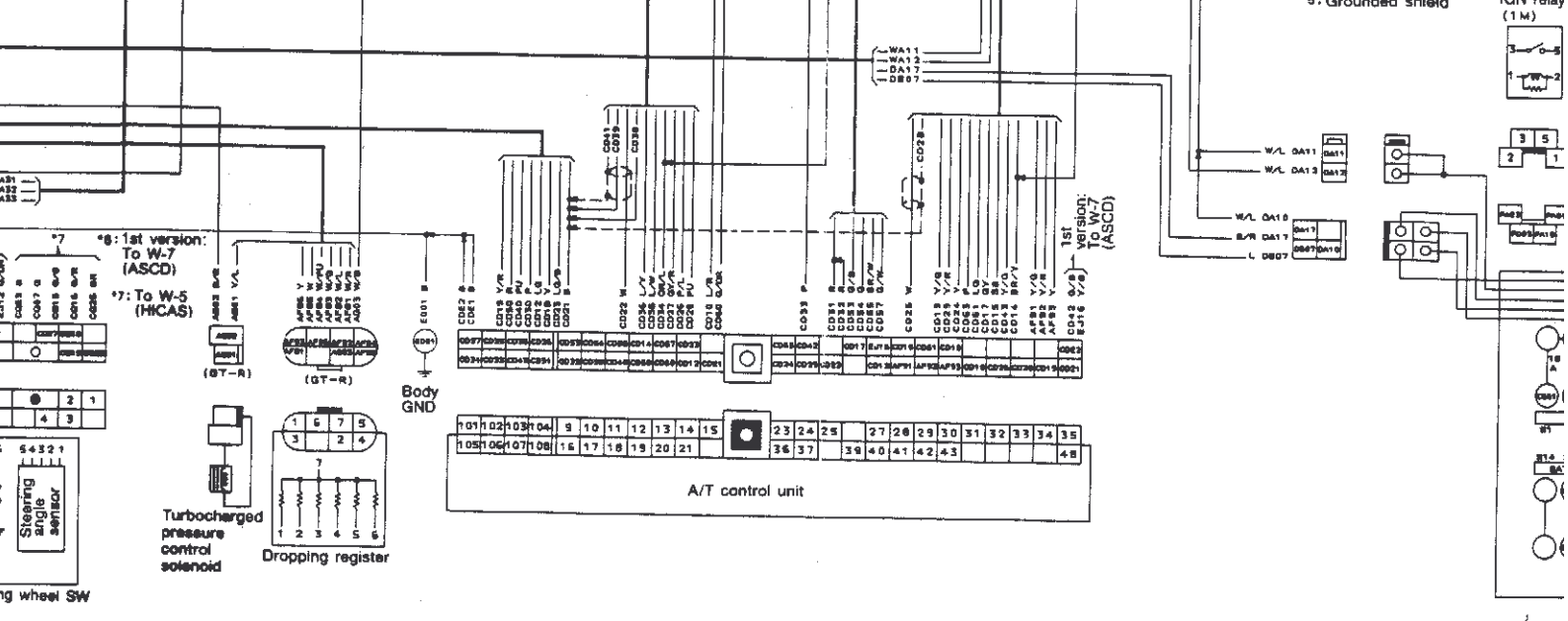

IGN relay (1M)

ing wheel SW

W	BC13	CCP1001
W	BC13	CCP1002
W	BC13	CCP1003
W	BC13	CCP1004
W	BC13	CCP1005
W	BC13	CCP1006
W	BC13	CCP1007
W	BC13	CCP1008
W	BC13	CCP1009
W	BC13	CCP1010
W	BC13	CCP1011
W	BC13	CCP1012
W	BC13	CCP1013
W	BC13	CCP1014
W	BC13	CCP1015
W	BC13	CCP1016
W	BC13	CCP1017
W	BC13	CCP1018
W	BC13	CCP1019
W	BC13	CCP1020
W	BC13	CCP1021
W	BC13	CCP1022
W	BC13	CCP1023
W	BC13	CCP1024
W	BC13	CCP1025
W	BC13	CCP1026
W	BC13	CCP1027
W	BC13	CCP1028
W	BC13	CCP1029
W	BC13	CCP1030
W	BC13	CCP1031
W	BC13	CCP1032
W	BC13	CCP1033
W	BC13	CCP1034
W	BC13	CCP1035
W	BC13	CCP1036
W	BC13	CCP1037
W	BC13	CCP1038
W	BC13	CCP1039
W	BC13	CCP1040

To body harness

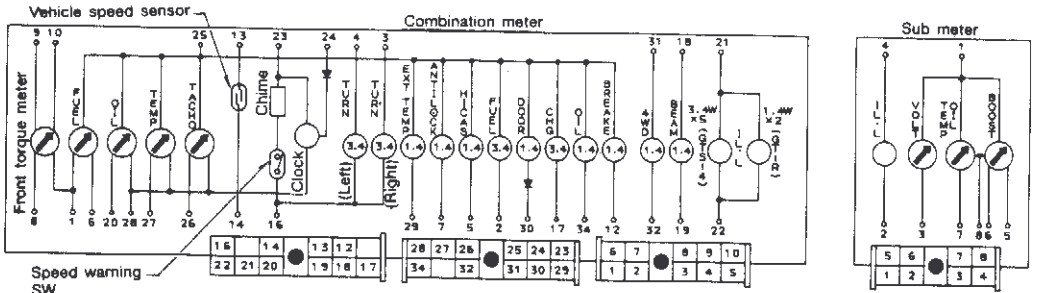

- *1: 1st version: To W-7 (ASCD)
- *2: To W-3 (E-TS)
- *3: To W-3 (E-TS)
- *4: To W-5 (HICAS)

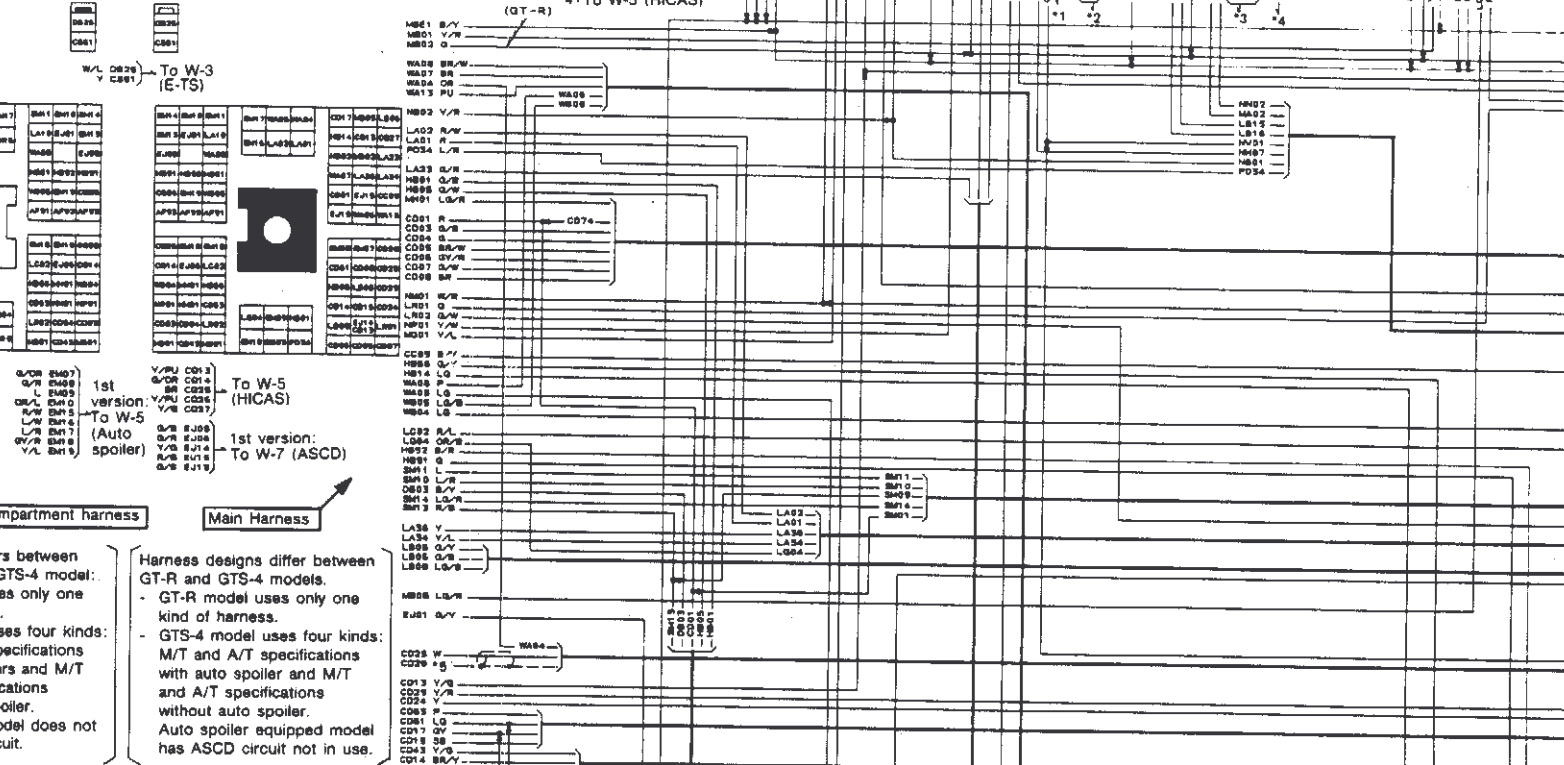

Harness designs differ between GT-R and GTS-4 models.

- GT-R model uses only one kind of harness.
- GTS-4 model uses four kinds: M/T and A/T specifications with auto spoiler and M/T and A/T specifications without auto spoiler.
- Auto spoiler equipped model has ASCD circuit not in use.

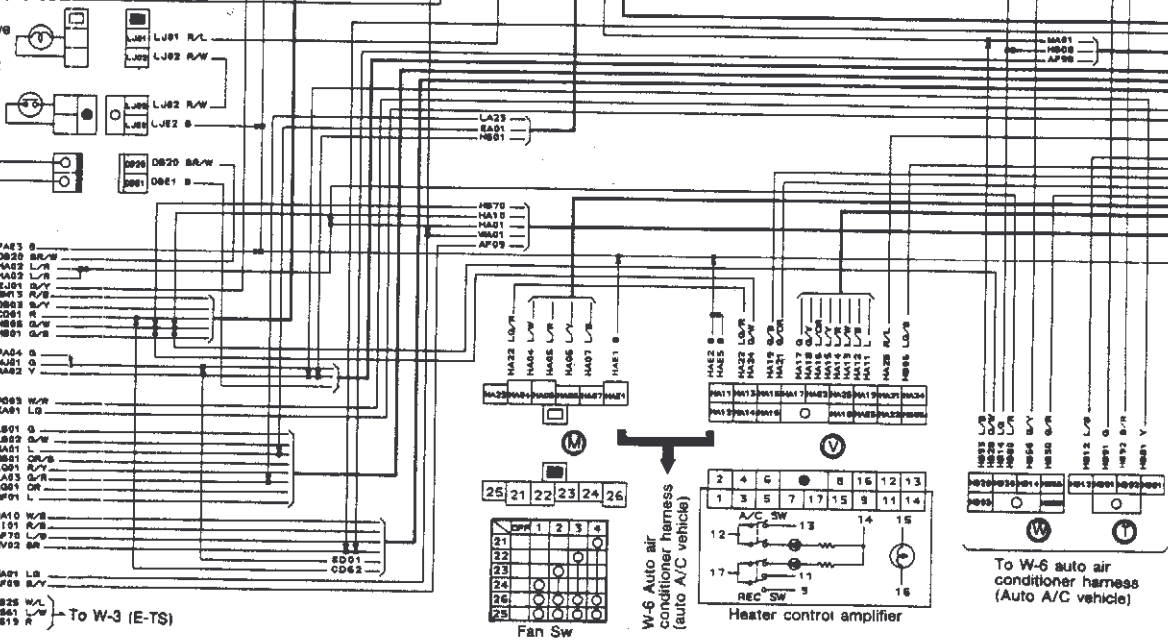
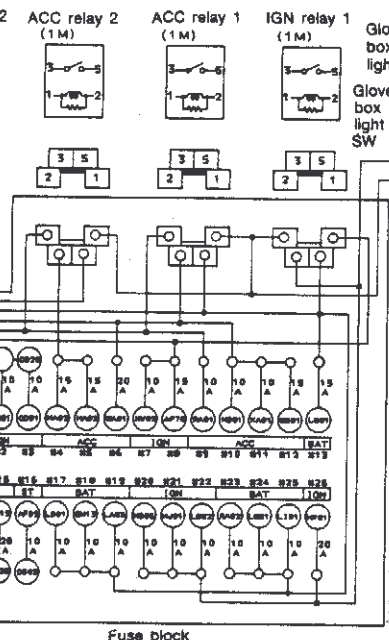

To W-6 auto air conditioner harness (Auto A/C vehicle)

Cont'd Fig. No. 2 W-1 4WD Vehicles (RB20DET/RB26DETT)

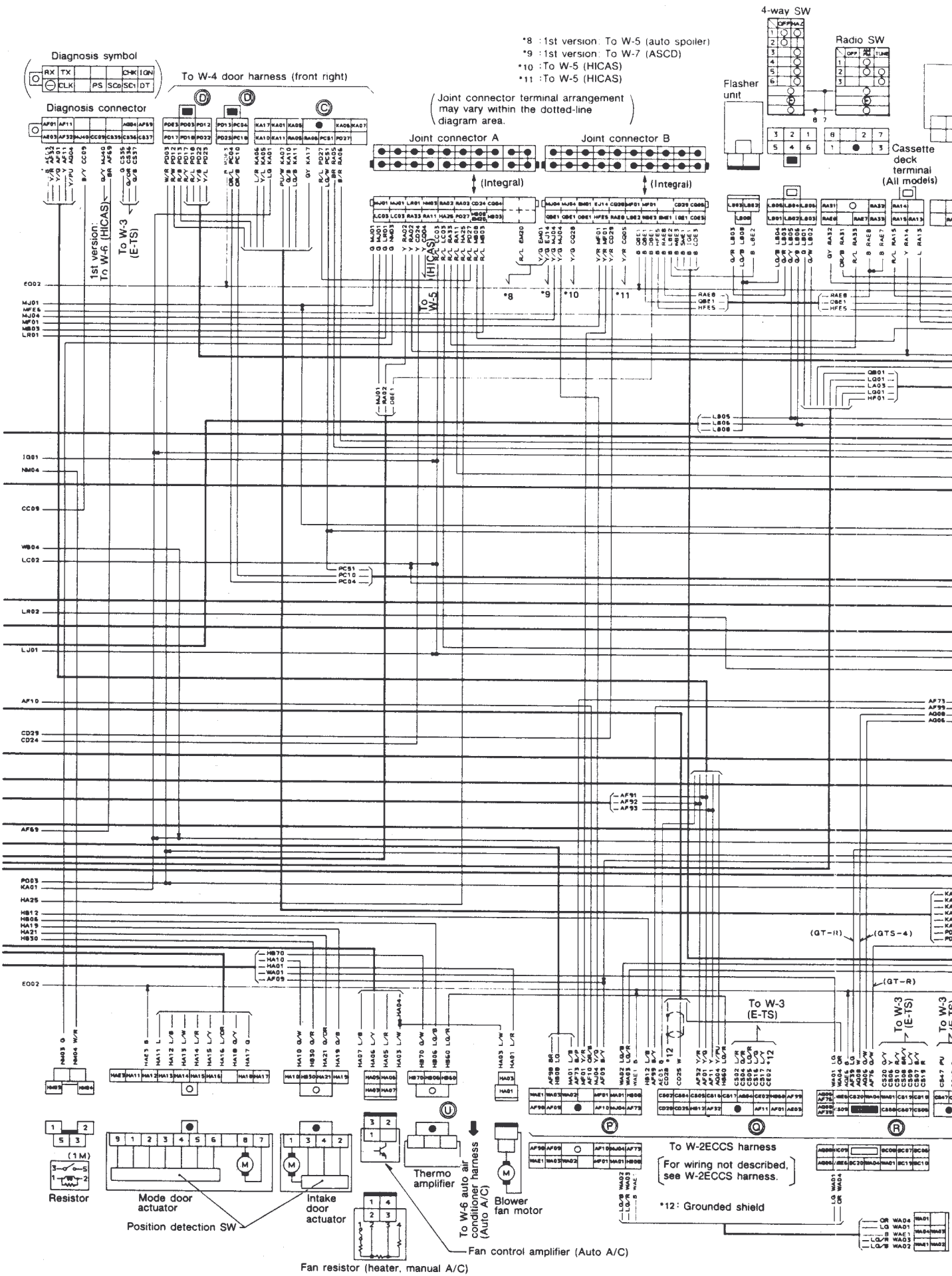

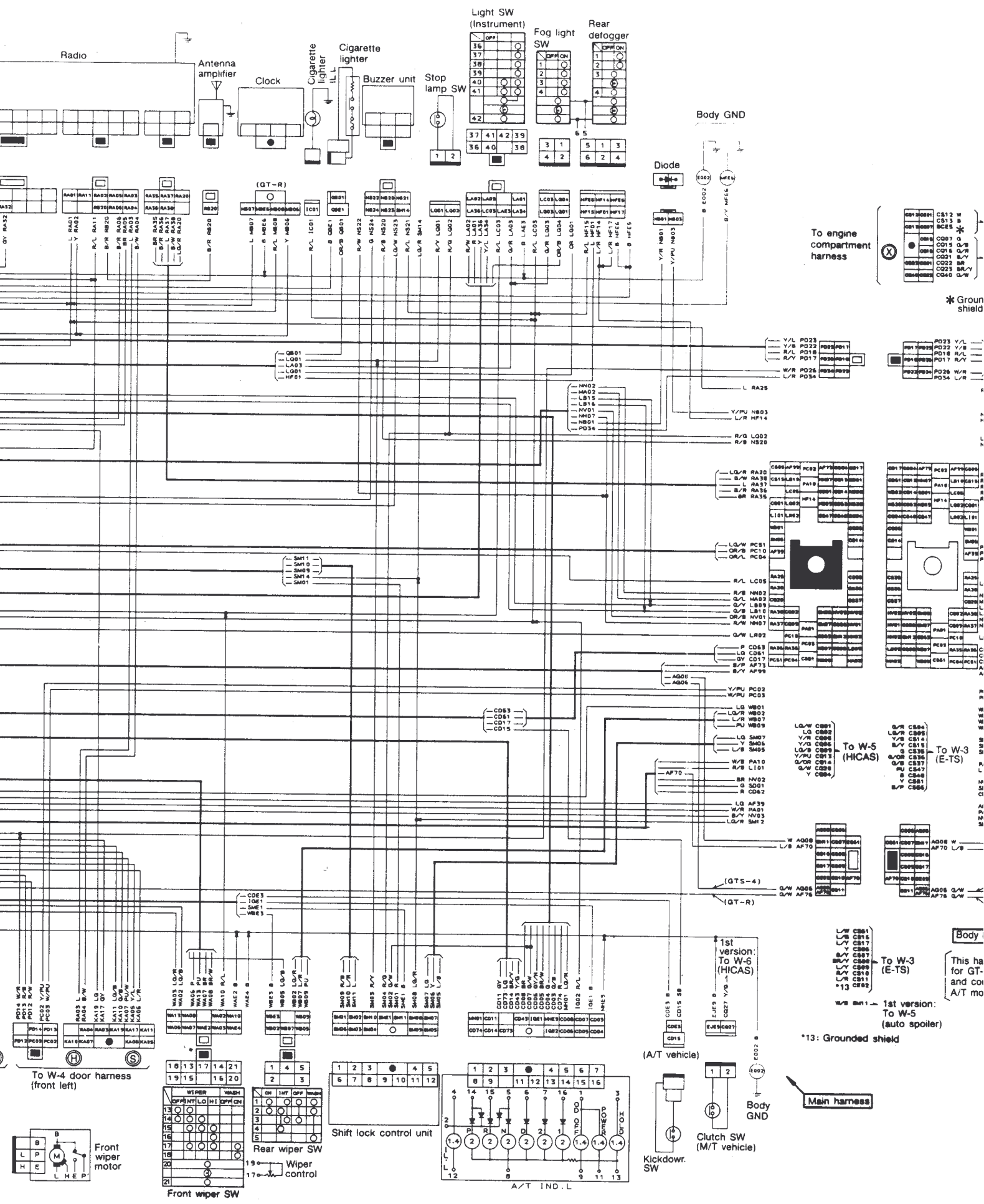

To engine compartment harness

* Ground shield

To W-5 (HICAS)
To W-3 (E-TS)

To W-3 (E-TS)
1st version: To W-5 (auto spoiler)

*13: Grounded shield

Body
This ha for GT and CO A/T mo

To W-4 door harness (front left)



Front wiper motor

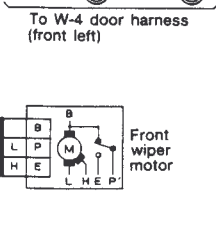

Front wiper SW

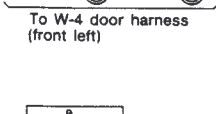

Rear wiper SW

Wiper control



Shift lock control unit

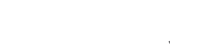

A/T IND. L

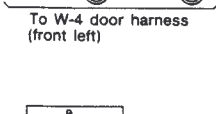

Clutch SW (M/T vehicle)



Kickdown SW



Body GND



Main harness

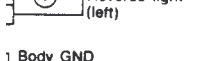
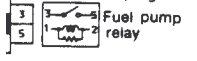
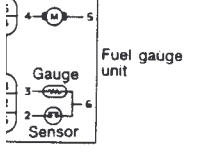
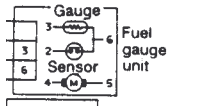
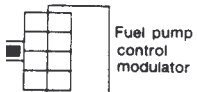
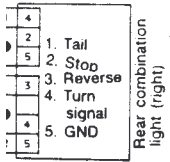

Body GND

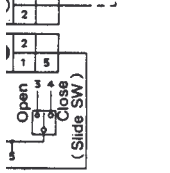
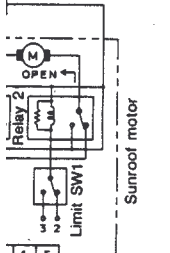
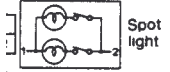
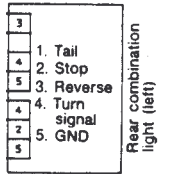

(03) RB26DETT

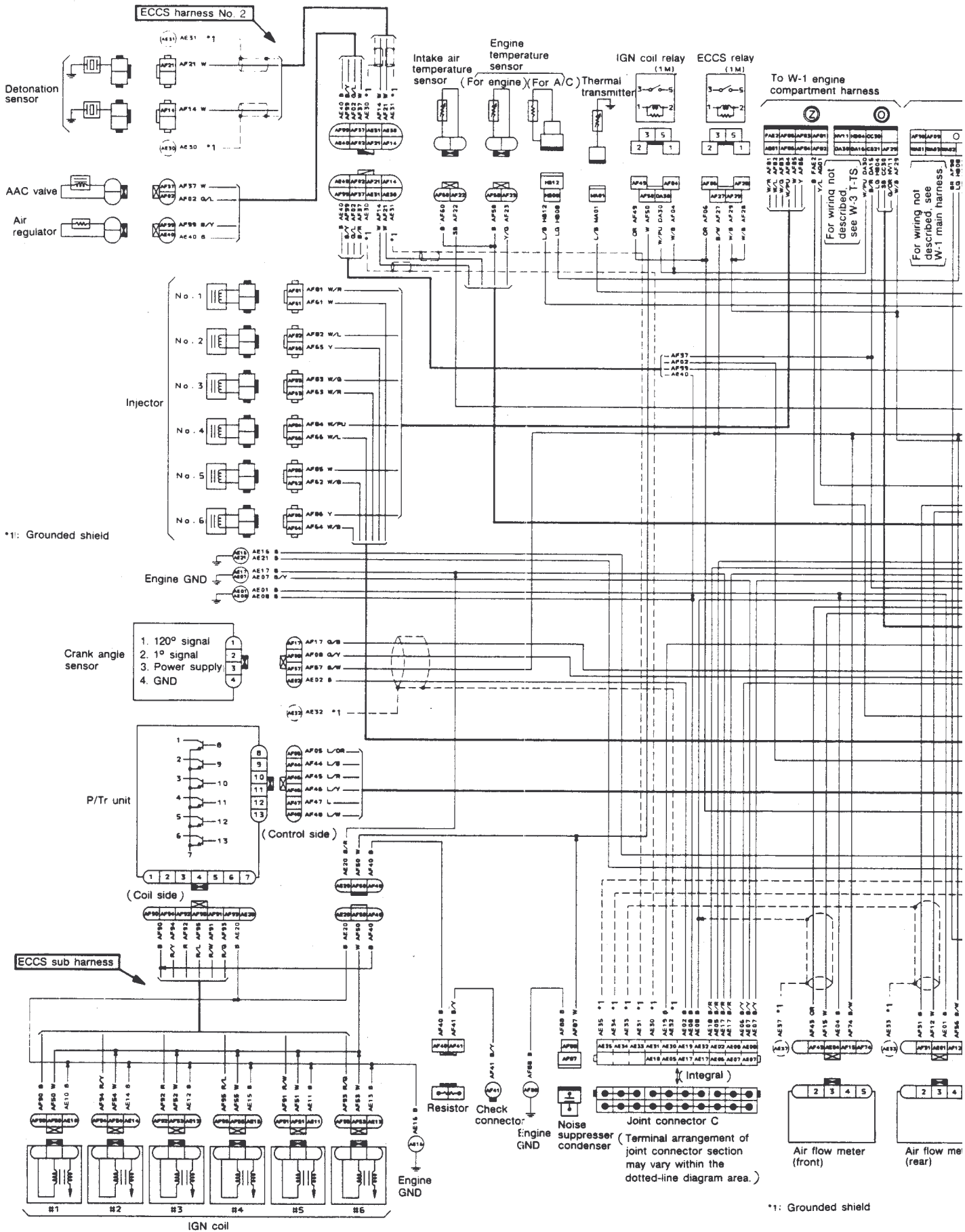

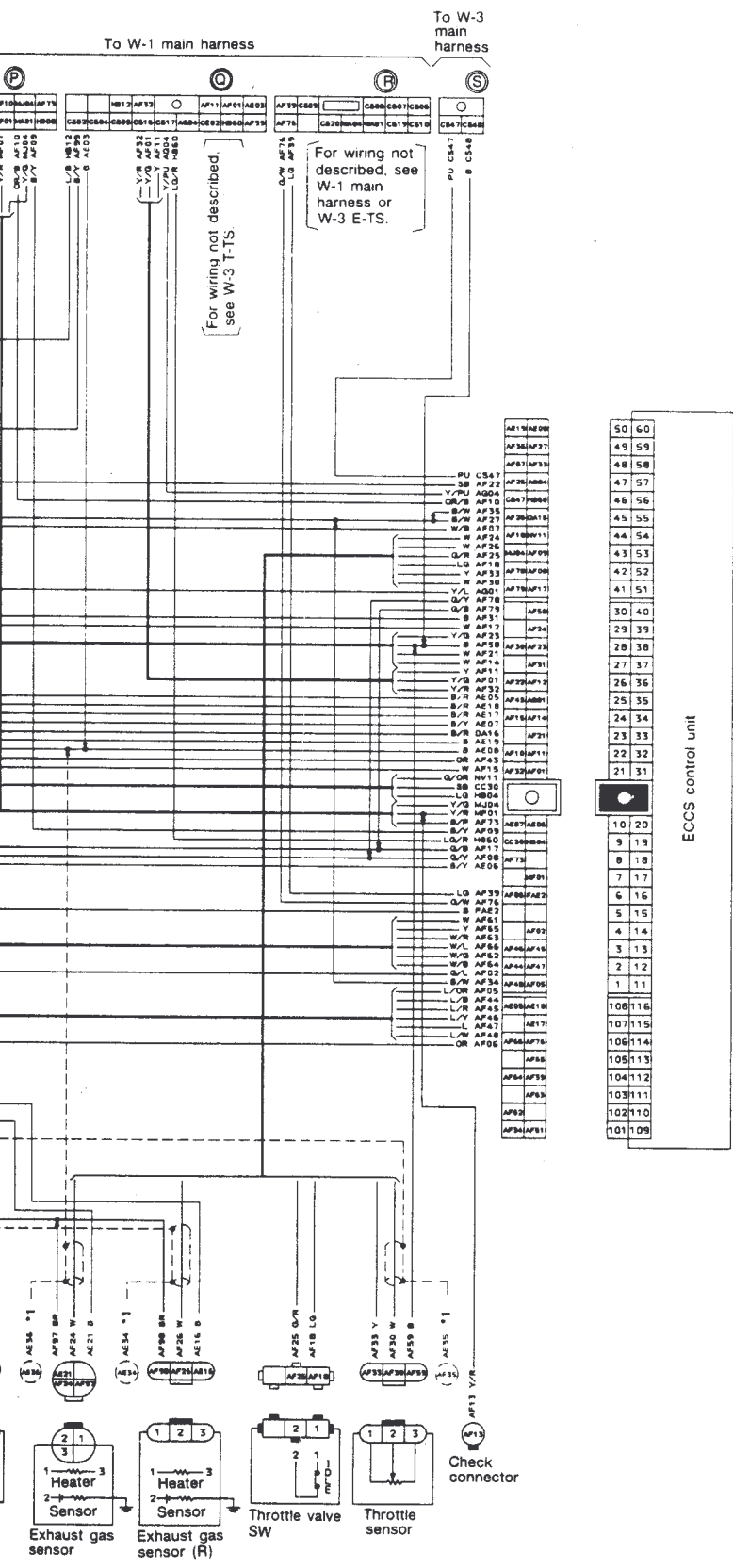

50	60
49	59
48	58
47	57
46	56
45	55
44	54
43	53
42	52
41	51
30	40
29	39
28	38
27	37
26	36
25	35
24	34
23	33
22	32
21	31
10	20
9	19
8	18
7	17
6	16
5	15
4	14
3	13
2	12
1	11
108	116
107	115
106	114
105	113
104	112
103	111
102	110
101	109

ECCS control unit

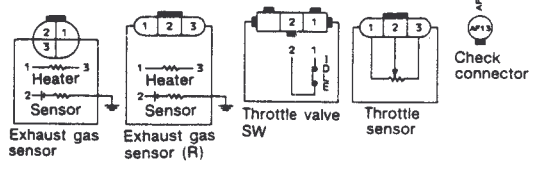
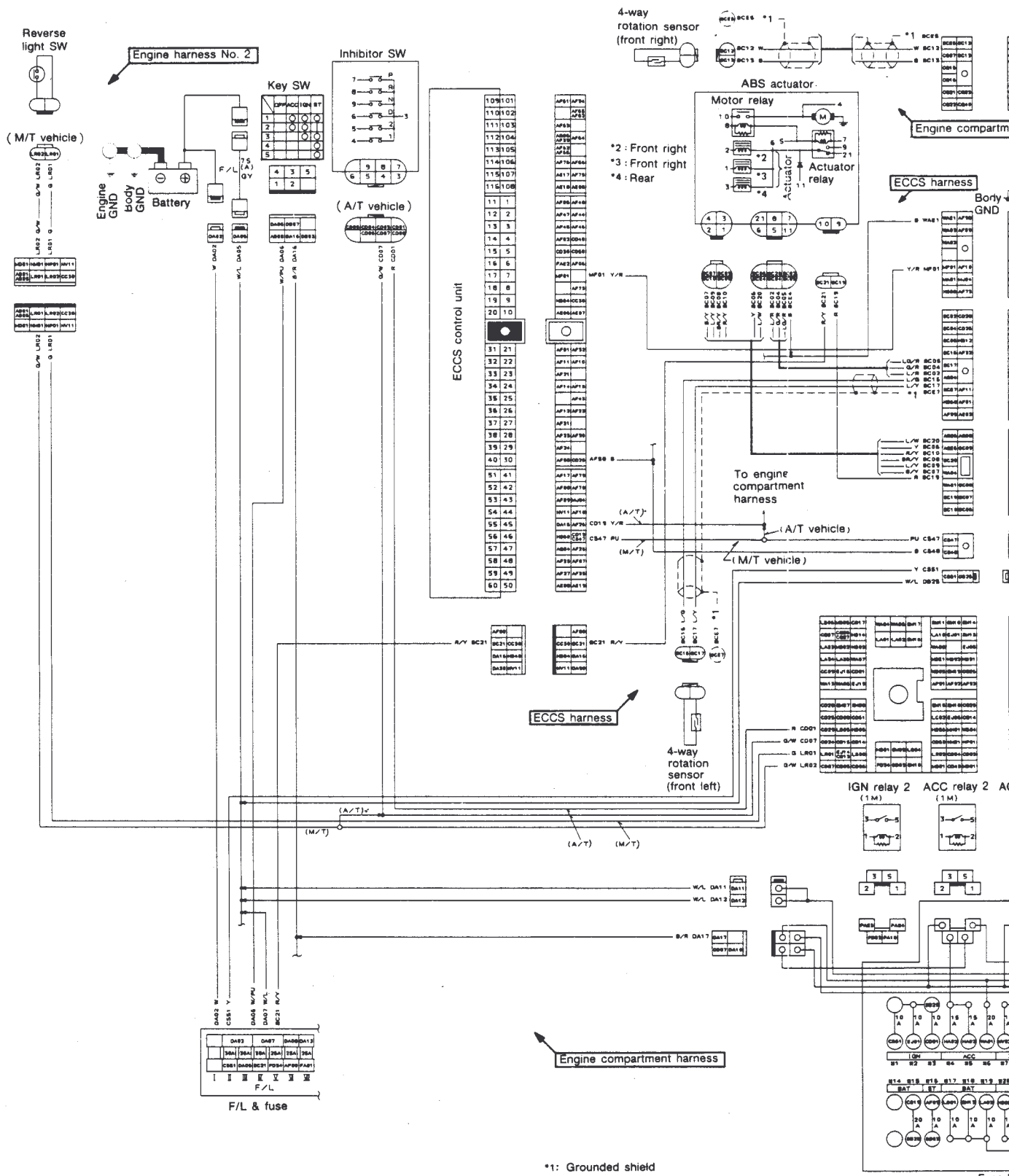

Fig. No. 5 W-3 E-TS SYSTEM



*1: Grounded shield

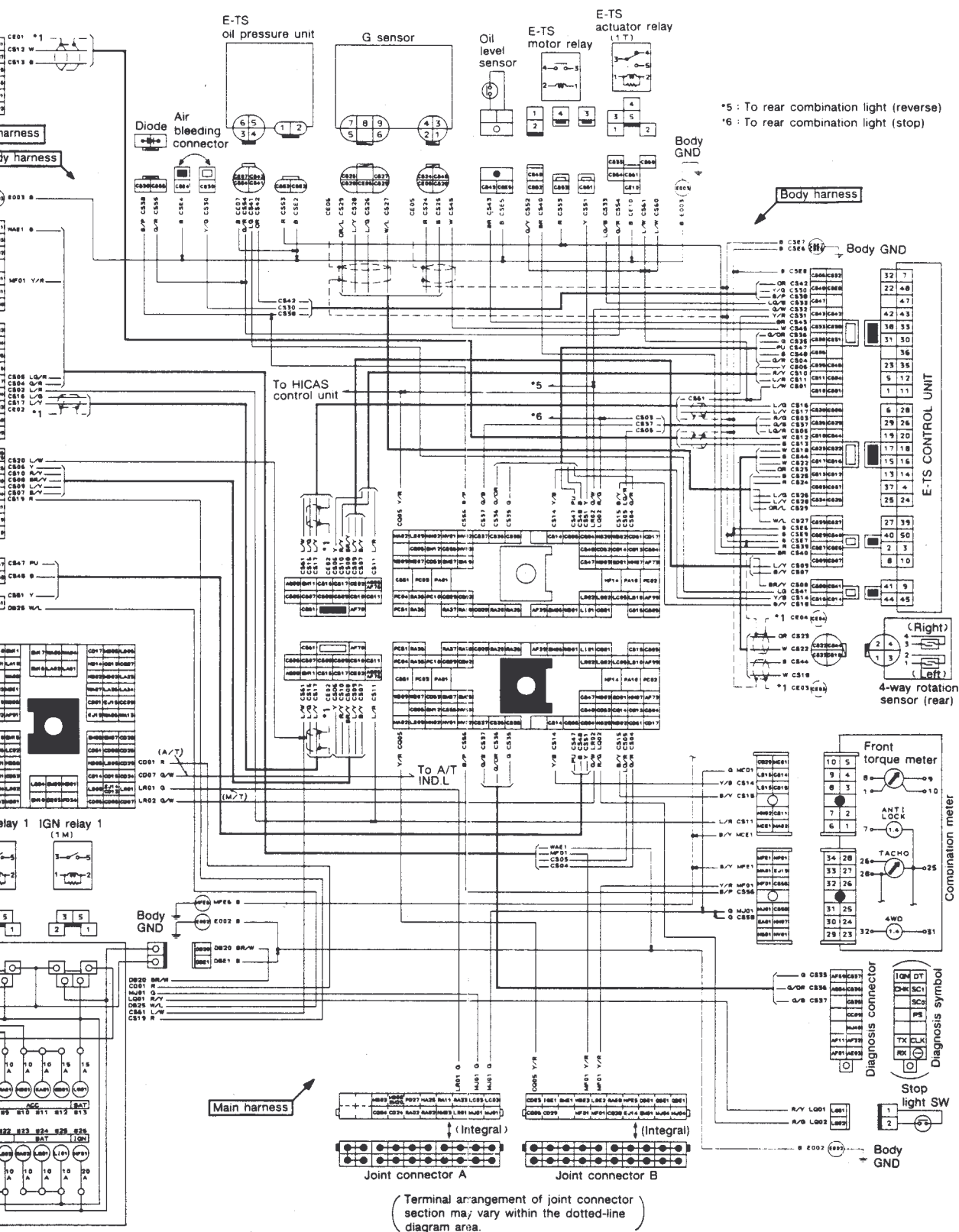
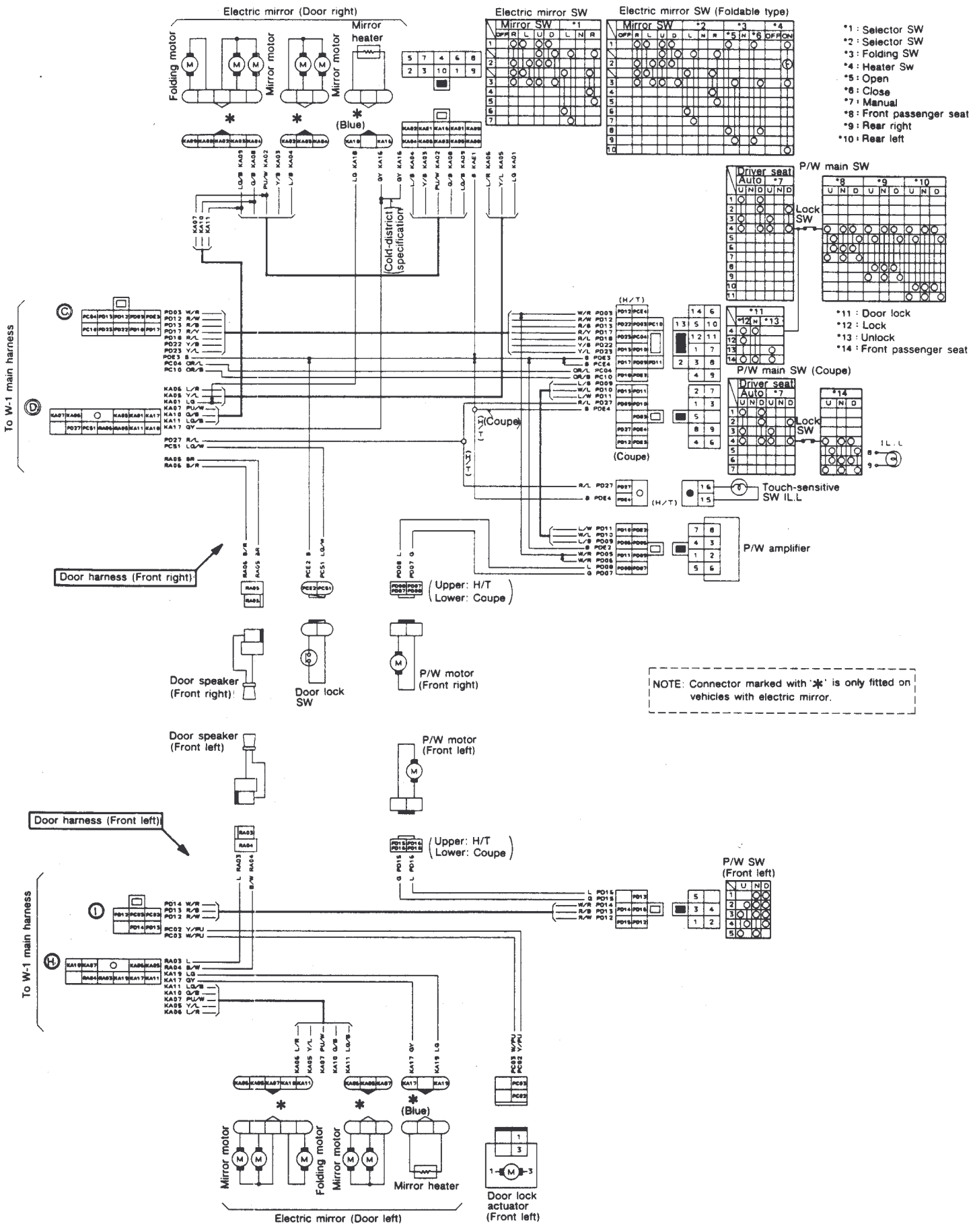

Fig. No. 6 W-4 DOOR HARNESS



- *1: Selector SW
- *2: Selector SW
- *3: Folding SW
- *4: Heater SW
- *5: Open
- *6: Close
- *7: Manual
- *8: Front passenger seat
- *9: Rear right
- *10: Rear left

- *11: Door lock
- *12: Lock
- *13: Unlock
- *14: Front passenger seat

NOTE: Connector marked with * is only fitted on vehicles with electric mirror.

Fig. 7 W-5 HICAS SYSTEM

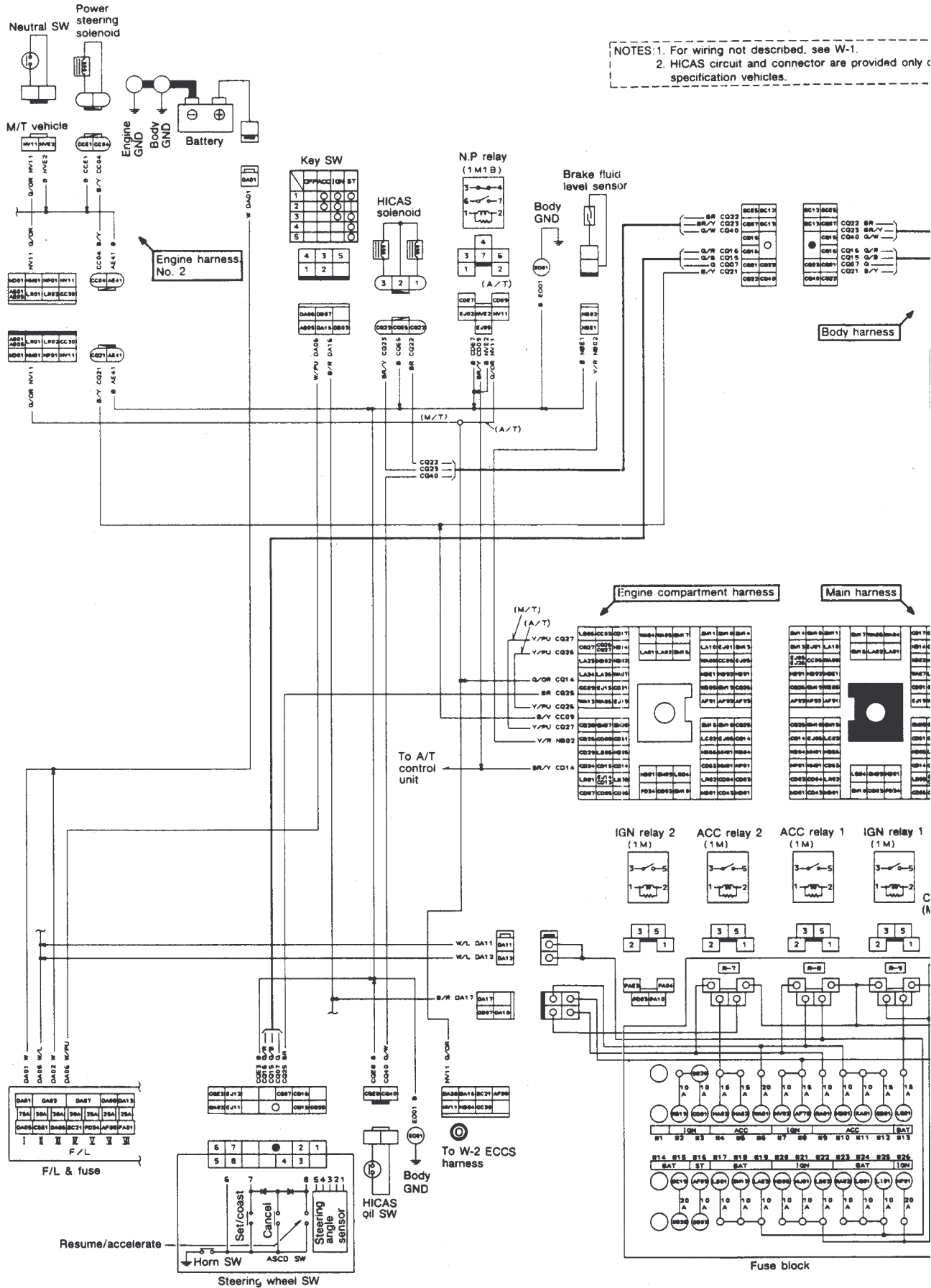

NOTES: 1. For wiring not described, see W-1.
 2. HICAS circuit and connector are provided only for specification vehicles.

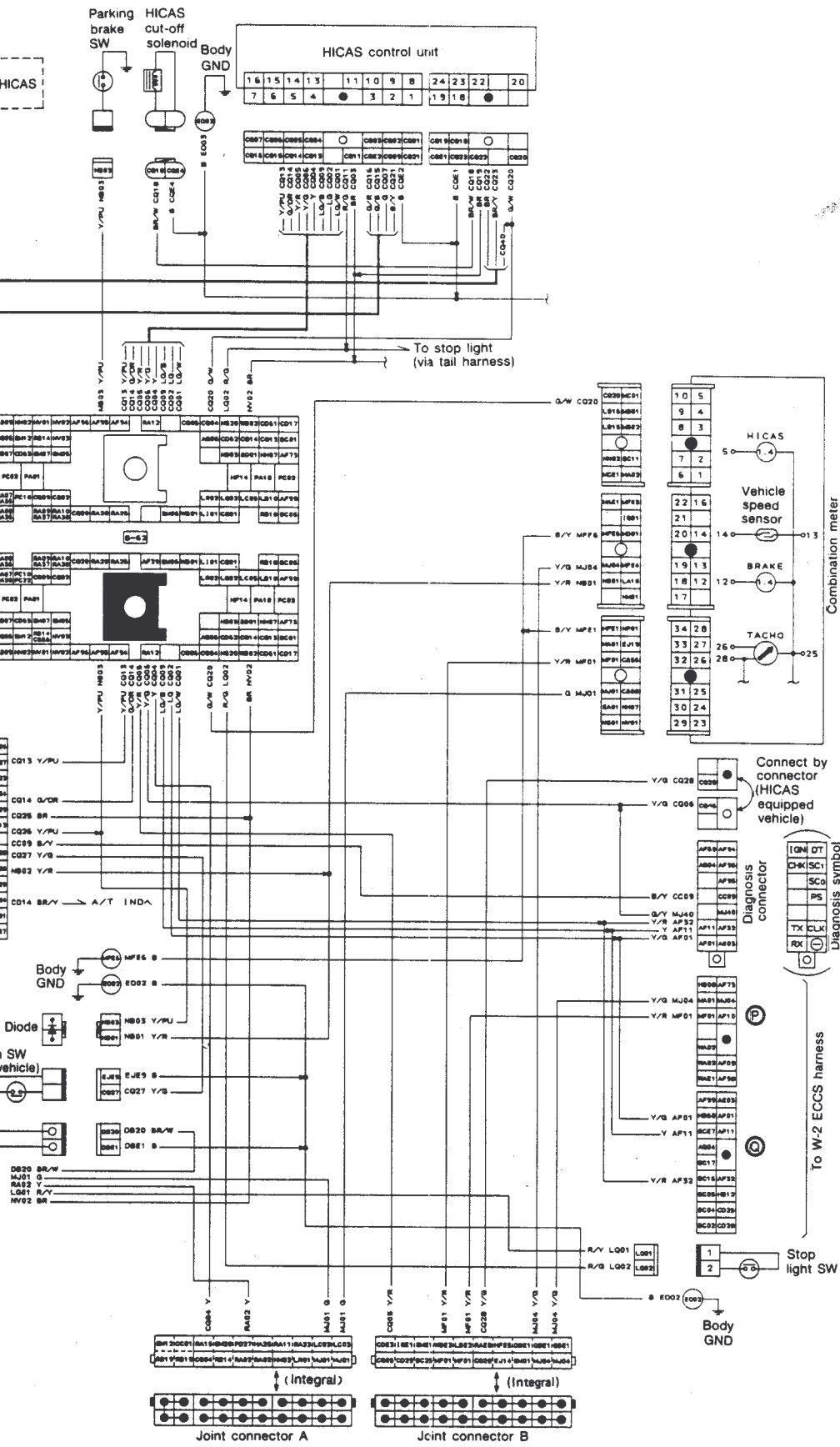

(Terminal arrangement of joint connector section may vary within the dotted-line area.)

Fig. No. 8 W-6 AIR CONDITIONER HARNESS

Electrically controlled active
full-automatic air conditioner

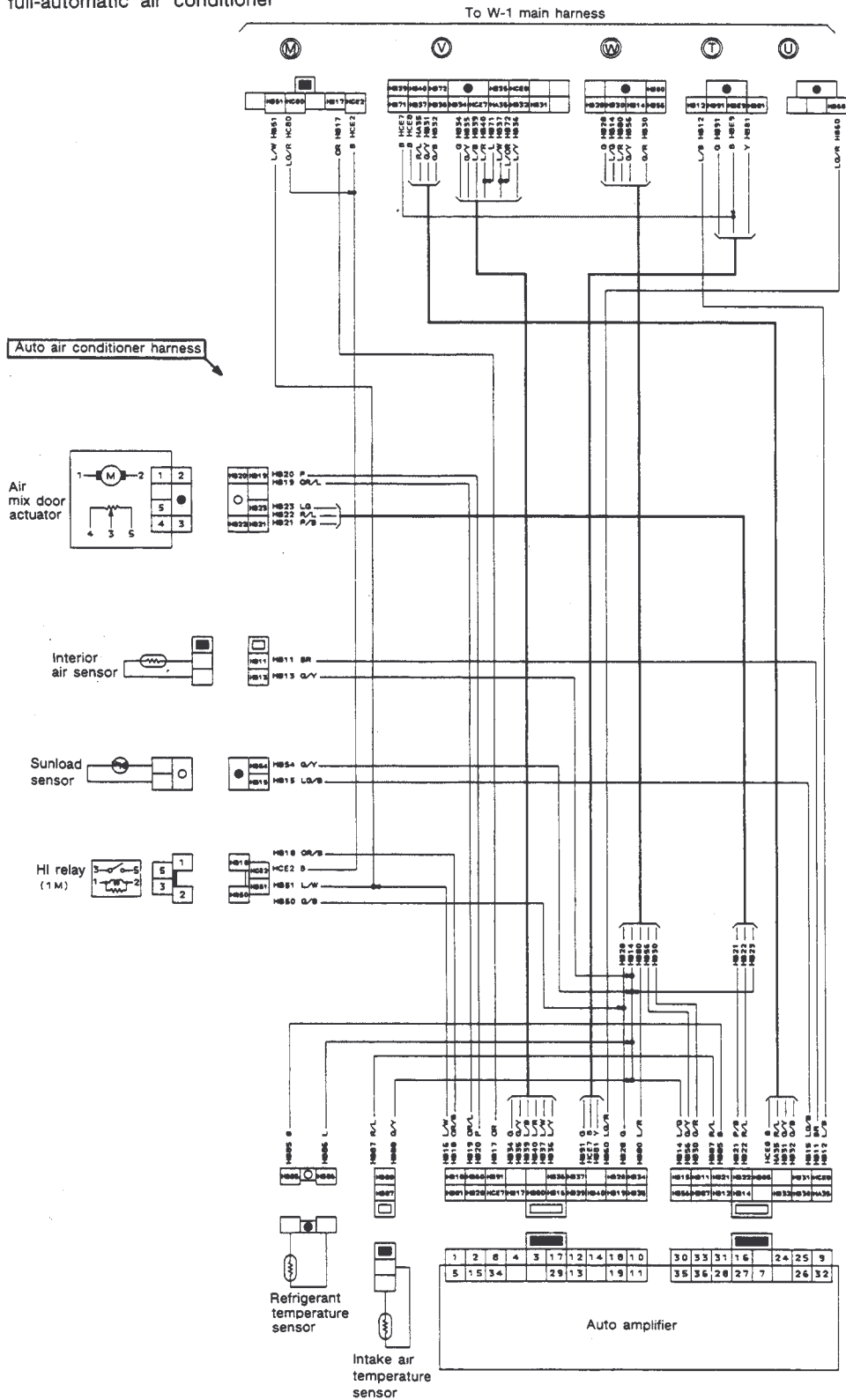

ENGINE COMPARTMENT – RELAY BOX

ENGINE COMPTARTMENT – RELAY BOX

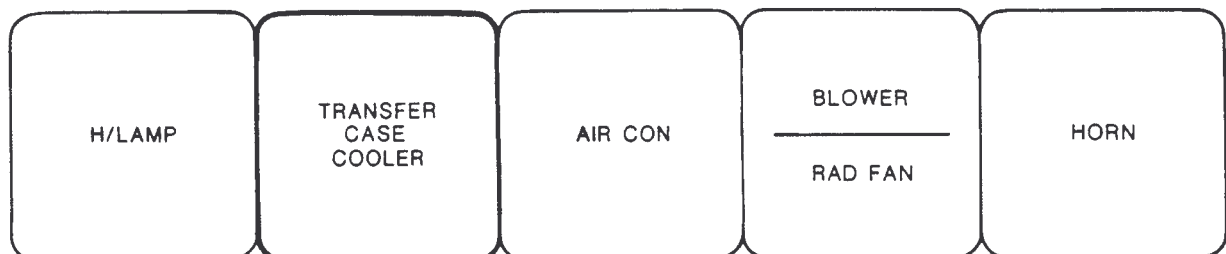
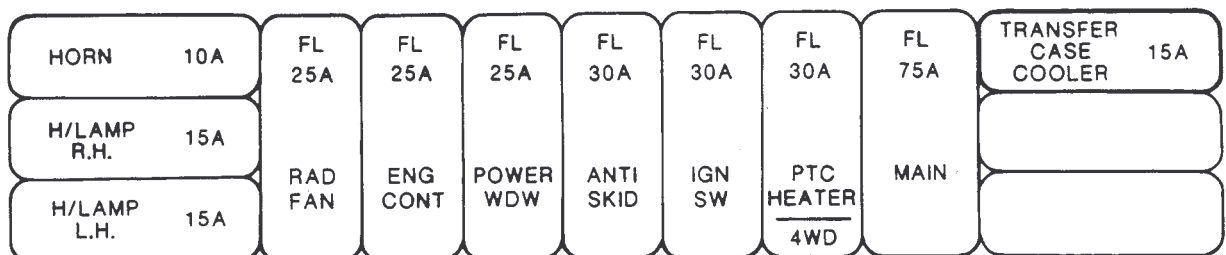

TRANSFER CASE COOLER

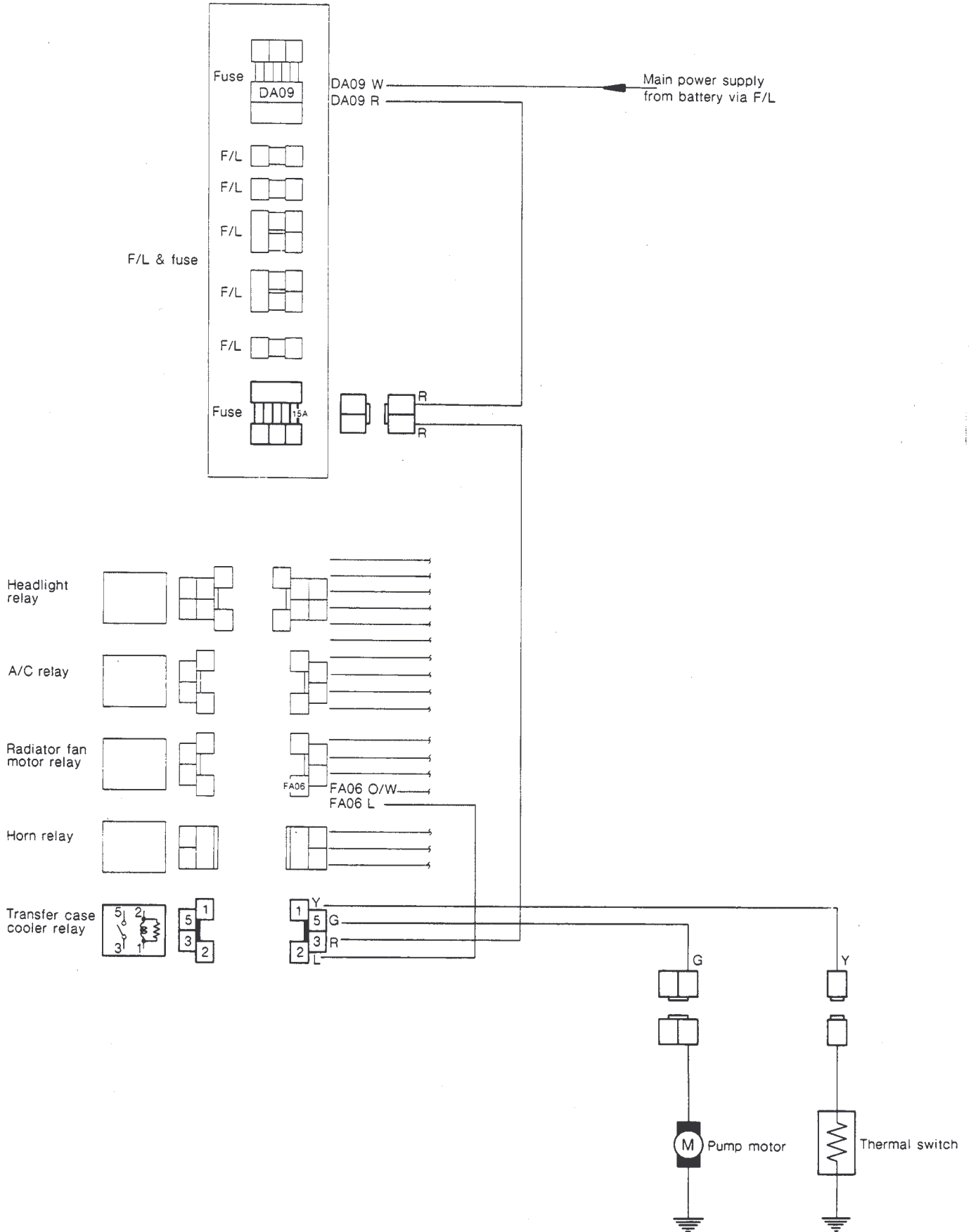

SIDE REPEATER LAMPS

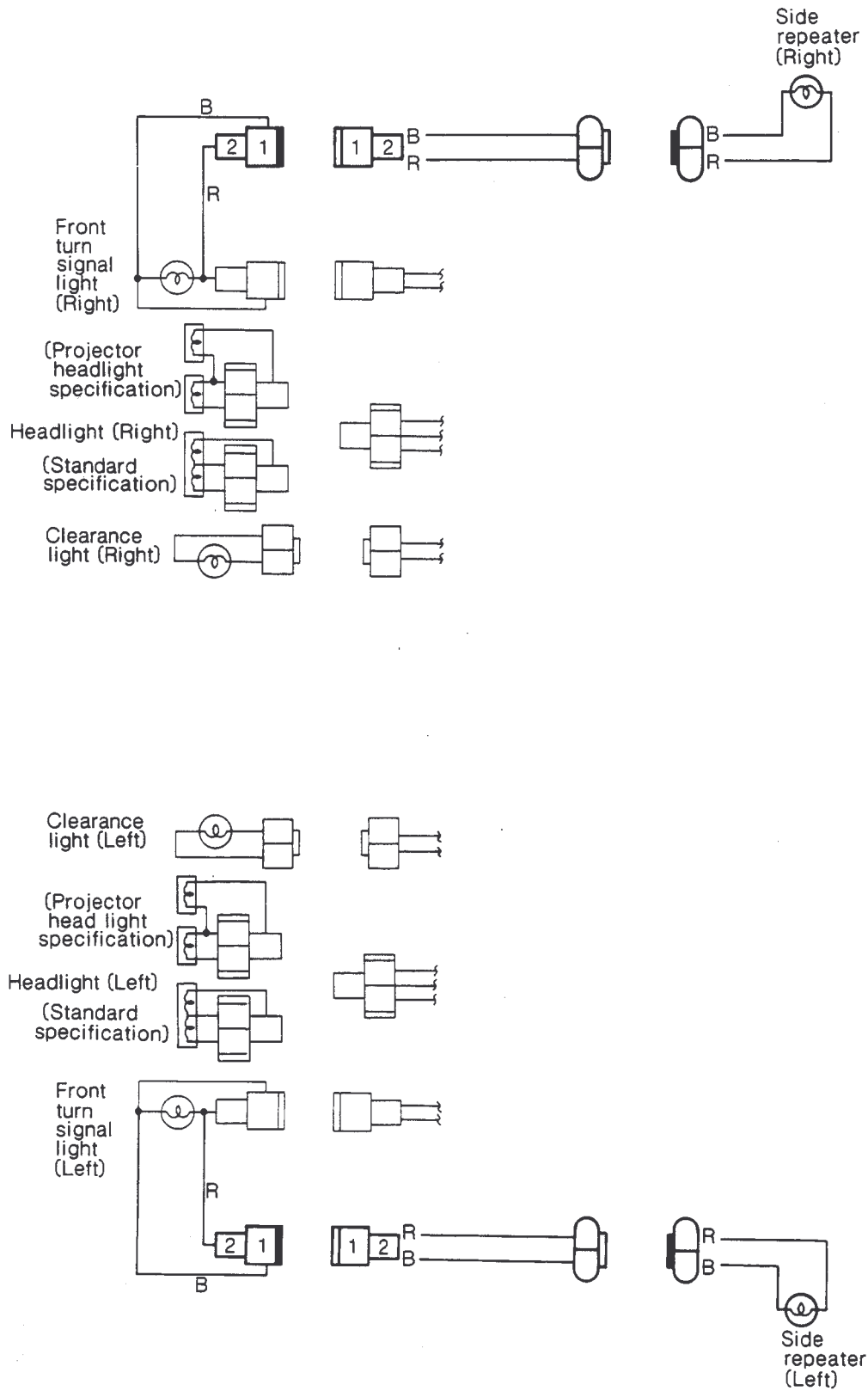

OIL TEMPERATURE WARNING BRAKE LIGHT WARNING DIMMER SW INSTRUMENT PANEL ILLUMINATION

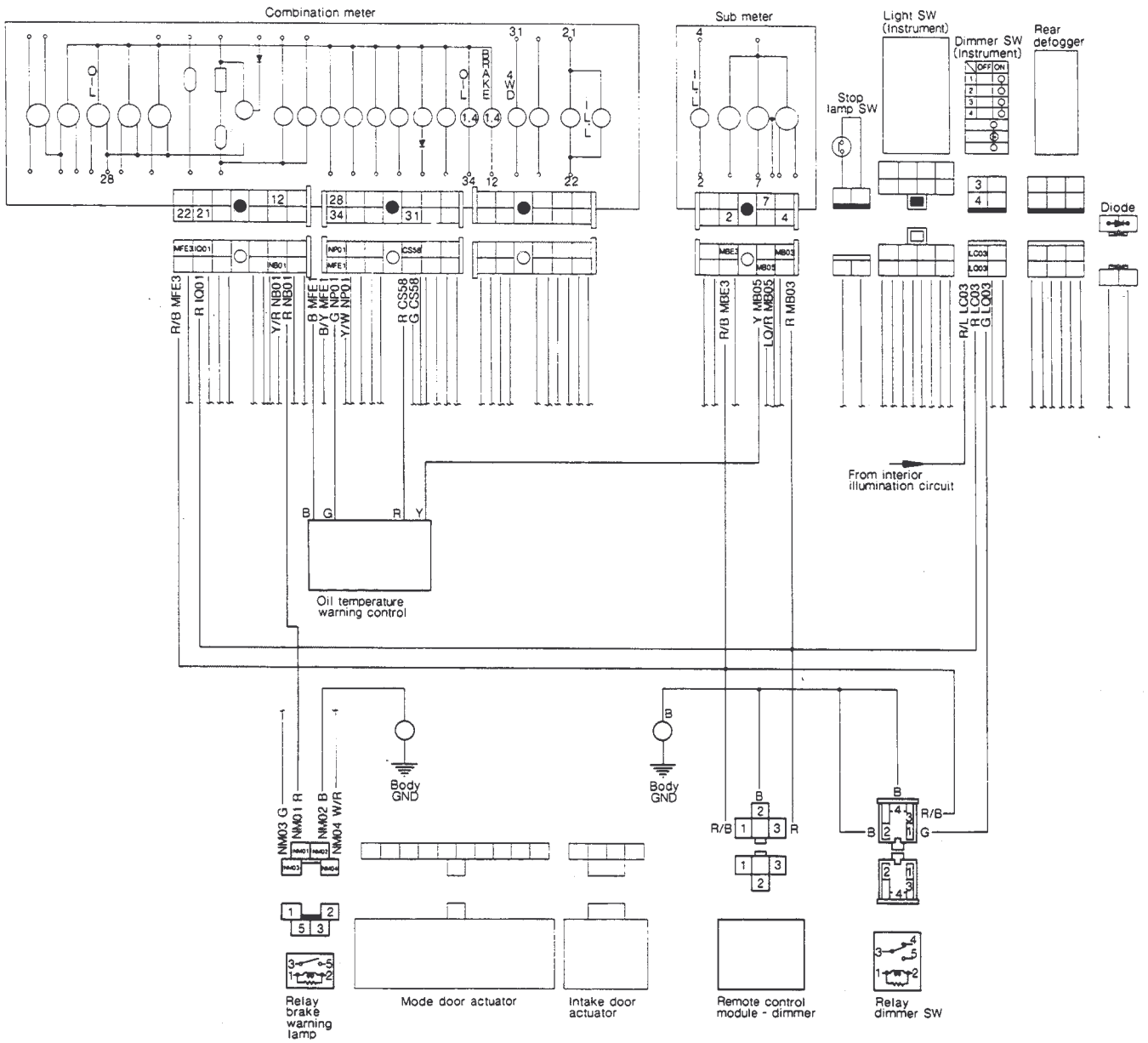

REAR LAMPS AND H.M.S.L.

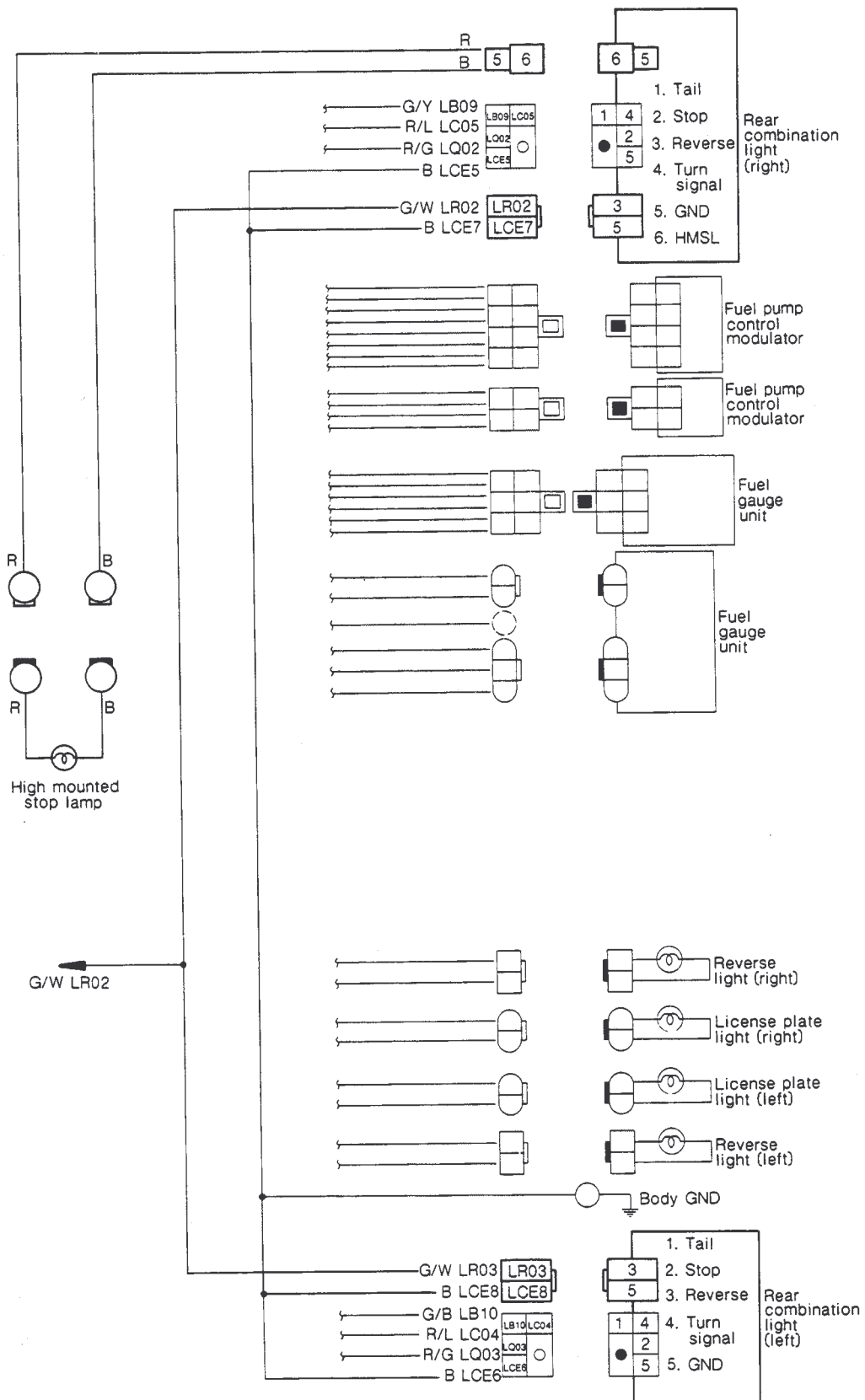

TRANSFER CASE COOLER

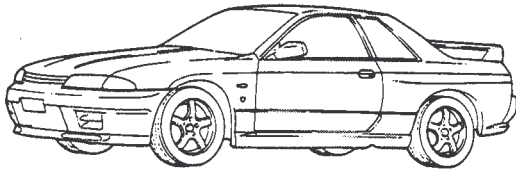

A

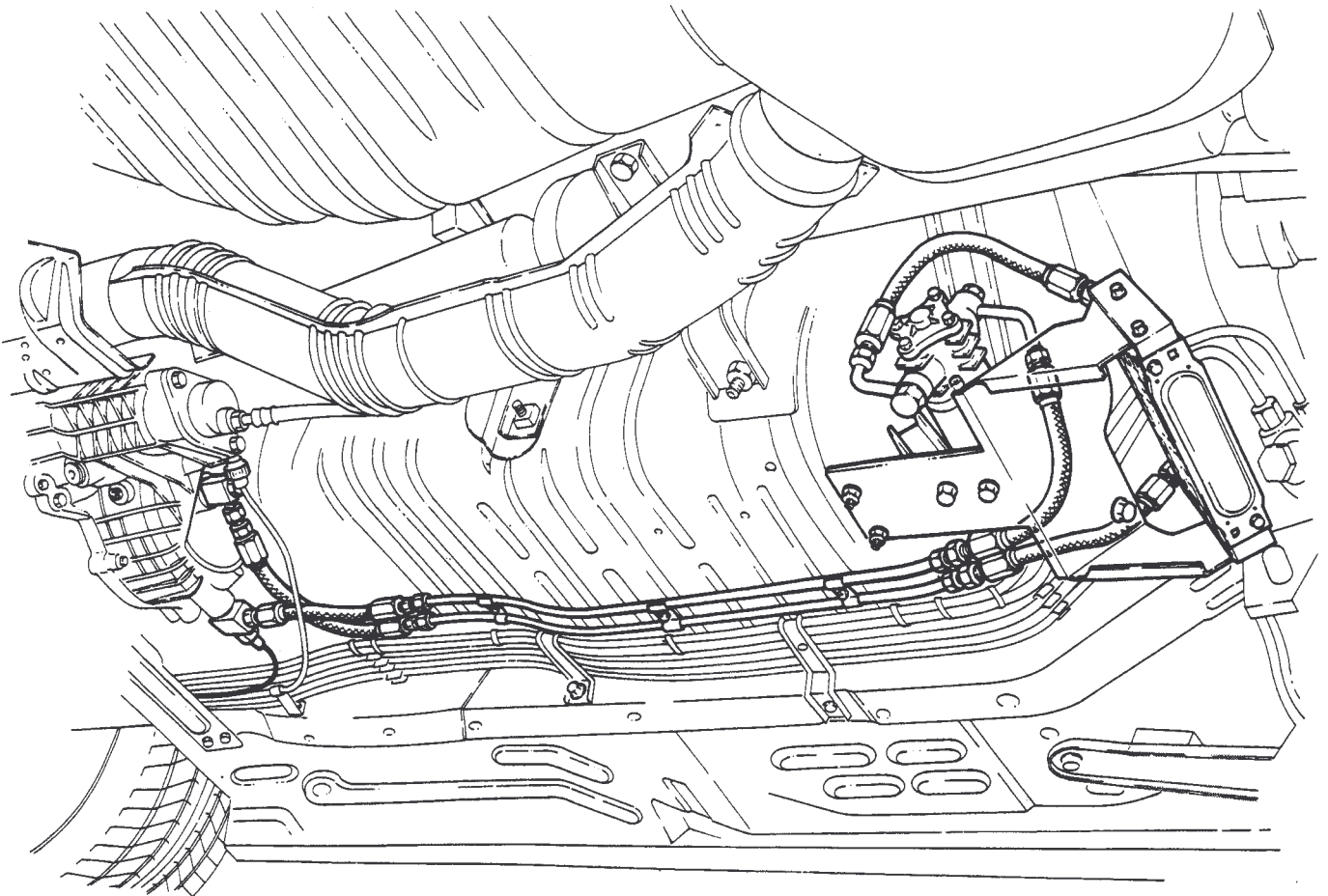

VIEW A

AUS-6

ETC ELECTRONIC TORQUE SPLIT CONTROLLER

HKS ELECTRONICS TECHNOLOGY



Pursuing the Ultimate in Engine Performance and Efficiency.
HKS Company Limited

札幌営業所 (011)723-1110
仙台営業所 (022)259-2626
東京営業所 (0425)81-4080
名古屋営業所 (052)354-6833
大阪営業所 (0727)28-3663
広島営業所 (082)871-1020
福岡営業所 (092)471-5931

ETC取扱説明書

この度は、HKSエレクトロニック トルク スプリット コントローラー (ETC)をお買い上げ下さいまして誠にありがとうございます。本商品は、精密機械であるため、取り付けに際しては本書にしたがって、充分注意して行って下さい。お取付の前に取扱説明書をよくお読み下さい。お読みになった後は大切に保管して下さい。

特徴

- ノーマルのETSシステム(BNR32、HNR32に搭載)の作動に関わらず、前輪に伝えるトルクを任意に設定する事により、個々のドライバーの好みとするドライブフィーリングを得られる商品です。
- ETC作動中ノーマルのトルクメーターは、ETCのポリリュームで設定したトルク値を表示します。
- ETC作動中にABS(アンチロックブレーキ)が作動するとETCはノーマル復帰し、ABSの作動が停止すればETCは、ON又はAUTOに戻ります。

目次

パーツリスト	1
全体配線図	2
取付方法	3
ETC本体説明	4
注意事項	5

1 パーツリスト

- ETC本体 1ヶ
- ETCリレーボックス 1ヶ
- ETCハーネス 1ヶ
- 延長ハーネス 1本
- 両面テープ 3ヶ
- 取扱説明書 1部
- 保証書 1部

2 全体配線図

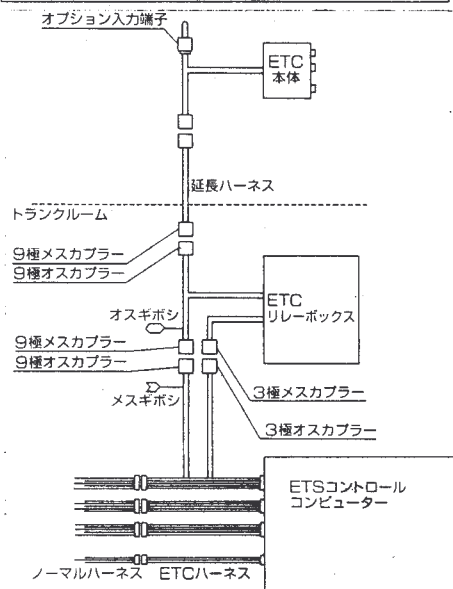

3 取付方法

- (1) バッテリーの(-)端子を外します。
- (2) トランクルーム内にあるETSコントロールユニットに、ETCハーネスを接続します。
- (3) リレーボックスから出ている9極メスカプラーと3極メスカプラーにETCハーネスから出ている9極オスカプラーと3極オスカプラーを接続します。
- (4) リレーボックスをハーネスの届く範囲で、両面テープにて固定して下さい。
- (5) トランクルームから延長ハーネスを室内に通し、リレーボックスから出ている9極オスカプラーに延長ハーネスの9極メスカプラーを接続します。
- (6) ETCハーネスから出ているメスキボシ端子とリレーボックスから出ているオスキボシ端子を接続します。
- (7) ETC本体を、室内に通した9極カプラーに接続し、両面テープ等で任意の場所へ固定して下さい。
- (8) バッテリーの(-)端子を接続します。

4 ETC本体説明

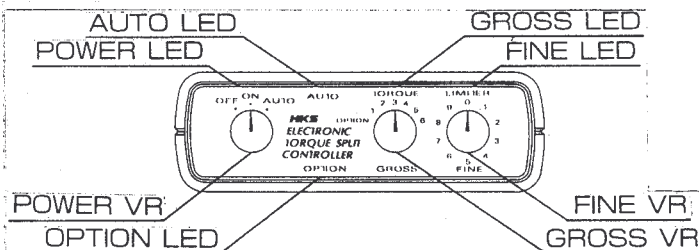

- (1) POWERポリリューム
OFF ノーマル状態
ON 常時GROSS、FINEポリリュームで設定したトルクを前輪にかけます。
AUTO 車速がおおよそ15km/h以上でGROSS、FINEポリリュームで設定したトルクを前輪にかけ、車速が15km/h以下でノーマル状態になります。

(2) GROSSポリリューム

OPTION ETCには、OPTION入力端子が装備されており、後にシステムの拡張が可能となっております。
1~6 前輪にかけられるトルクをだまかに設定出来ます。

(3) FINEポリリューム

0~9 前輪にかけられるトルクを微調整出来ます。

LED点灯条件

- POWER LED IG ONで常時点灯
AUTO LED POWERポリリュームがAUTOモードでなおかつ、車速がおおよそ15km/h以上で点灯。
GROSS FINE LED POWERポリリュームがON又はAUTOモードで点灯(但しAUTOモードでは車速がおおよそ15km/h以上になった時点灯)
OPTION LED POWERポリリュームがON又はAUTOで、且つGROSSポリリュームがOPTIONを選択した時に点灯(但しAUTOモードでは車速がおおよそ15km/h以上になった時点灯)

(注) ABS作動中はAUTO LED、GROSS LED、FINE LEDともに消灯し、ABS解除後は、上記のように点灯します。

5 注意事項

- ETCを取付、使用する際以下の注意事項を必ず守って下さい。
- (1) バッテリーの(-)端子を外してから、作業を行って下さい。
 - (2) ETCは、構造上完全なFRとは成らず前輪に多少のトルクがかかるため、パワーチェックの際には、フロントプロペラシャフトを外すか、エンジンルーム内に有る4WDのヒューズブルリンクを外し2WDに成っている事を確認のうえ行って下さい。
 - (3) 前輪に常に高トルクをかけていると駆動系に負担がかかりますので、必要の無いときはノーマルもしくはFRに近い状態で使用して下さい。