

AVANTI II

ELECTRICAL

CIRCUITS

BLOCK

DIAGRAMS

Avanti II Electrical Diagrams

ELECTRICAL CIRCUIT BLOCK DIAGRAMS

1A	CHARGING & ELECTRICAL FEED CIRCUITS
1B	" " " " " - 1981
2A	STARTING CIRCUIT
3A	FUSE PANEL DIAGRAM - 1975
3C	" " " - 1976
4A	HEADLIGHT CIRCUIT
4B	PARK & TAIL LIGHT CIRCUITS
5A	DOME LIGHT FUSE CIRCUIT - 1975 & 1976
5B	" " " " - 1977
6	STOP LIGHT CIRCUIT
7	CLOCK CIRCUIT
8A	POWER DOOR LOCK CIRCUIT
8B	" " " " - 1978
9A	BURGLAR ALARM CIRCUIT
9B	BURGLAR ALARM & CIGAR LIGHTER CIRCUITS
10C	ELECTRIC ANTENNA (HARADA TYPE) -1980
10D	ANTENNA SWITCH DIAGRAM
11	POWER WINDOW & SUNROOF CIRCUITS
12	HAZARD WARNING CIRCUIT
13	A/C & HEATER CIRCUITS
14	DIRECTIONAL CIRCUIT
15A	INSTRUMENT FUSE CIRCUIT
15B	" " " - 1981
16A	BACK-UP LIGHT & TRANSMISSION KICK-DOWN CIRCUITS
16B	BACK-UP LIGHT CIRCUIT - 1981
17A	SEAT BELT LIGHT & BUZZER CIRCUITS - 1975 & 1976
17B	" " " " " " - 1977
18C	RADIO CIRCUIT DIAGRAM - 1977
19A	CRUISE CONTROL (A.C. TYPE) - 1976
19B	" " (DANA ELECTRONIC) - 1981
20	AUXILIARY LIGHT CIRCUIT
21D	W/S WIPER-WASHER W/INTERMITTANT CIRCUIT - 1981
22A	REAR WINDOW DEICER SYSTEM
22B	" " " " - 1963 & 1964
22C	DEICER OPERATION/CIRCUIT DESCRIPTION
22DE	DEICER PROBLEM & POSSIBLE CAUSE DIAGNOSIS
23	CHOKE HEATER CIRCUIT
24A	HORN CIRCUIT
24B	" " - 1979
25	STEER. COLUMN DIRECT. SIGNAL SWITCH CONNECTOR WIRE REPLACE.
26	FUSE BLOCK - 1984

IA

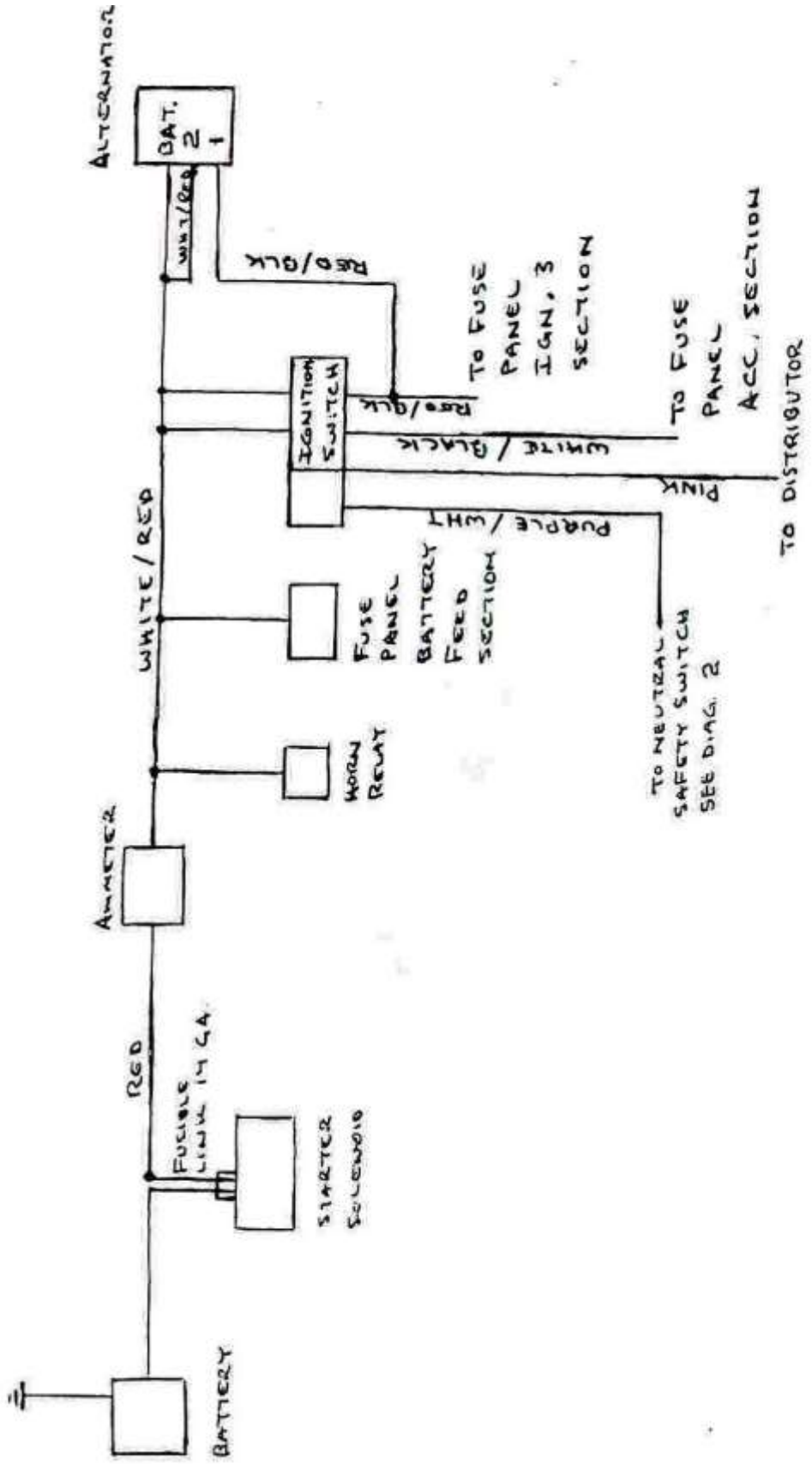

CHARGING AND ELECTRICAL FEED CIRCUITS

IB

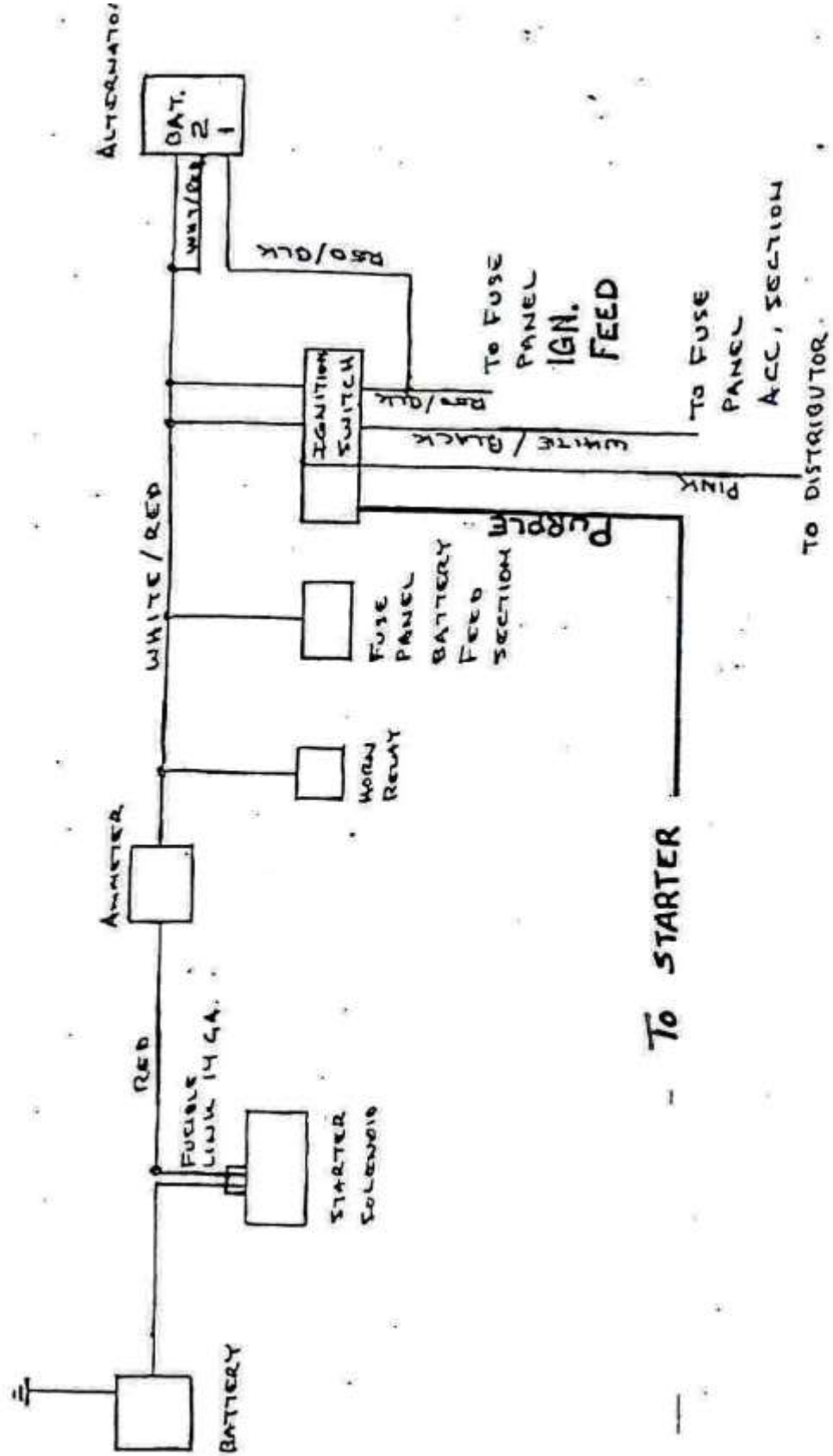

CHARGING AND ELECTRICAL FEED CIRCUITS 1981

2A

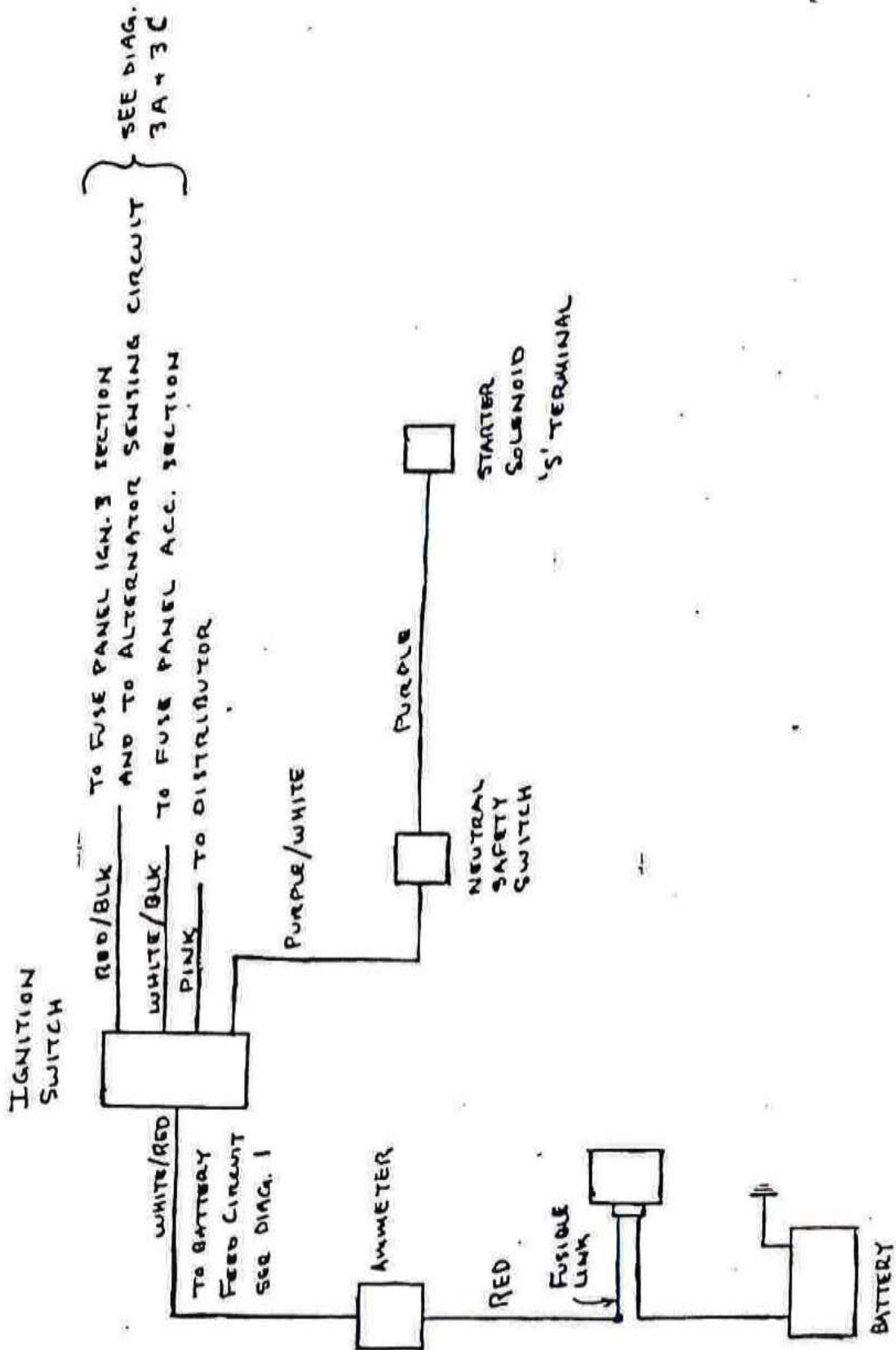

SEE DIAG. 3A+3C

STARTING CIRCUIT

3A

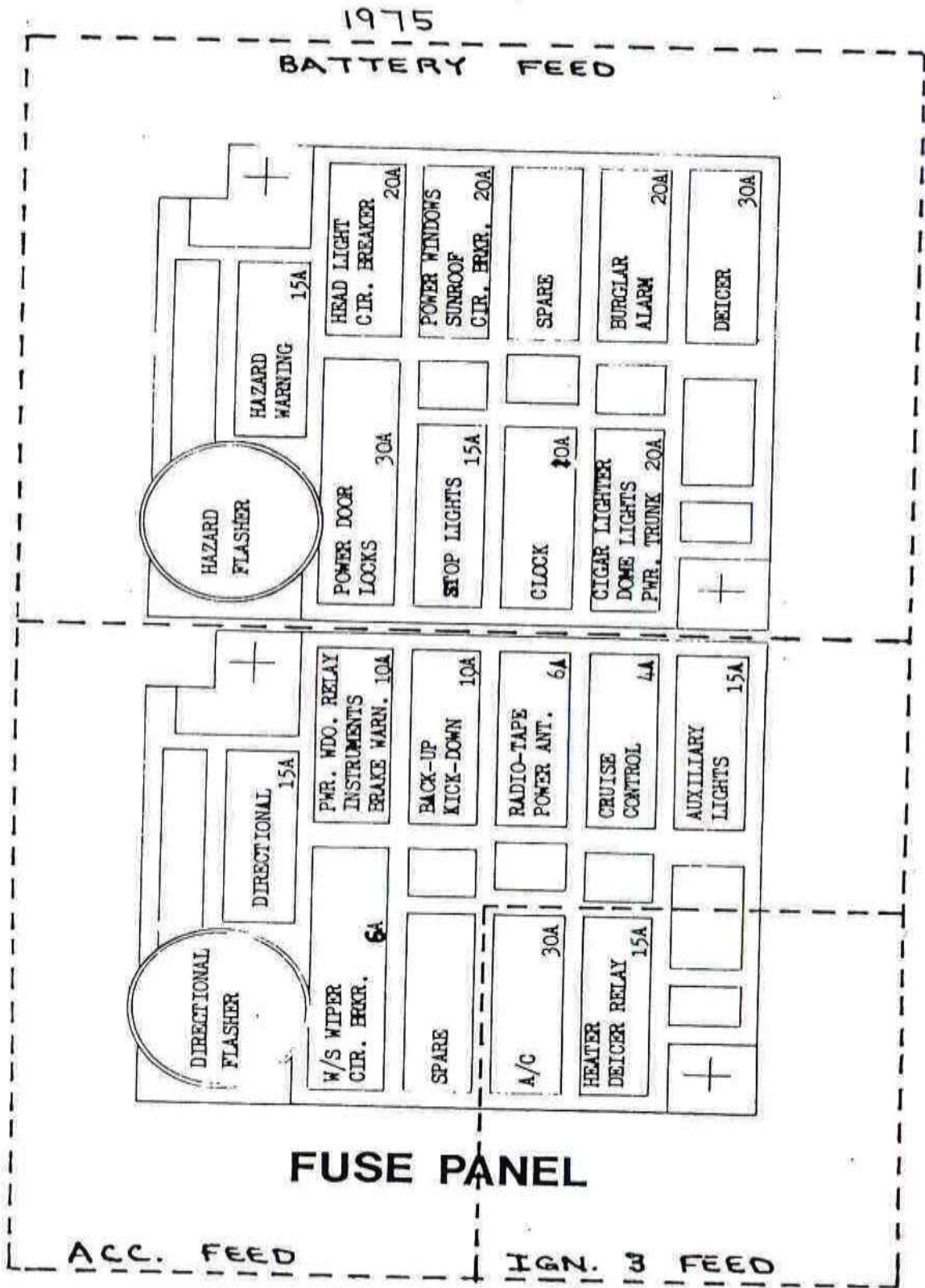

30

1976

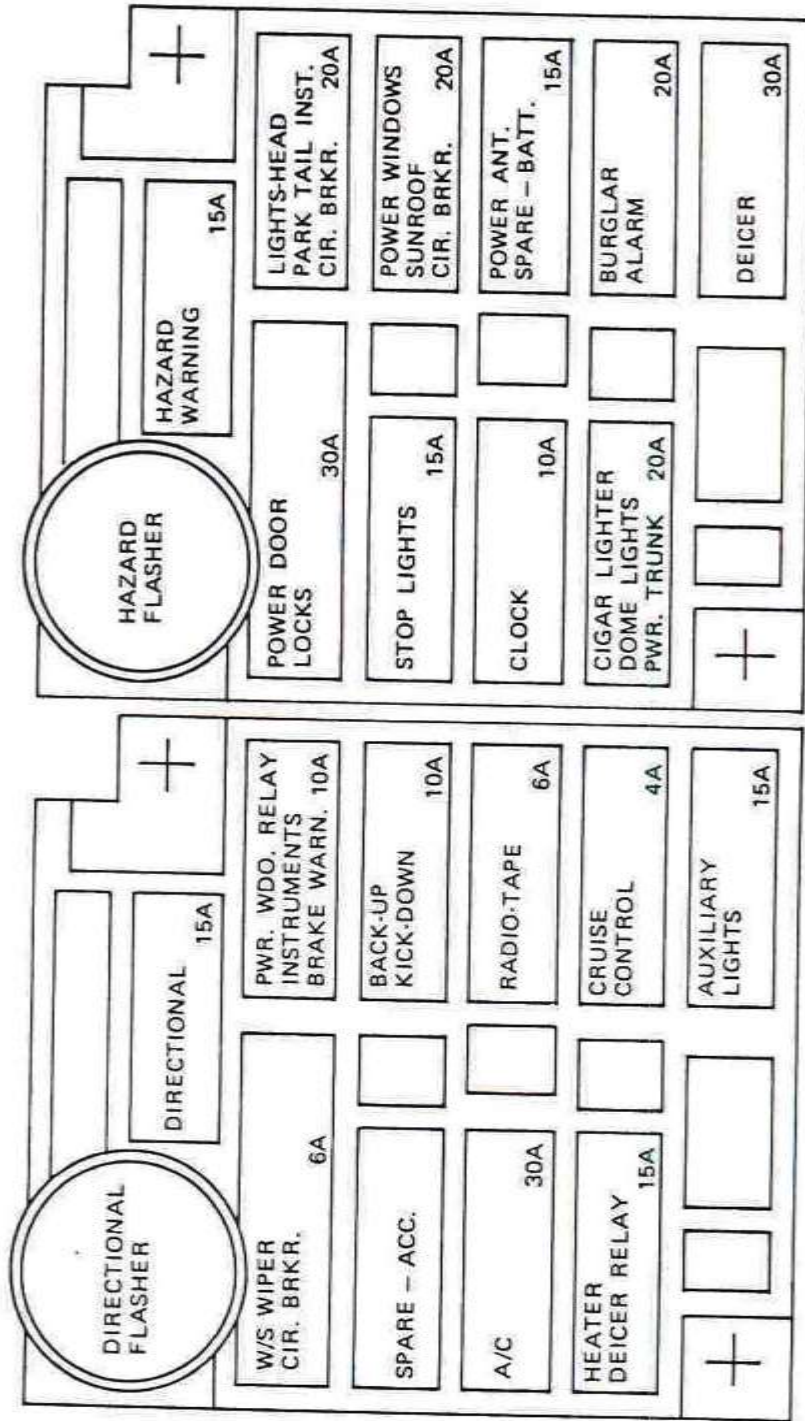

FUSE PANEL

NOTE:
 IN 1976 THE POWER ANTENNA FEED WAS MOVED FROM
 FROM THE ACCESSORY FEED SECTION TO THE BATTERY
 FEED SECTION.

4A

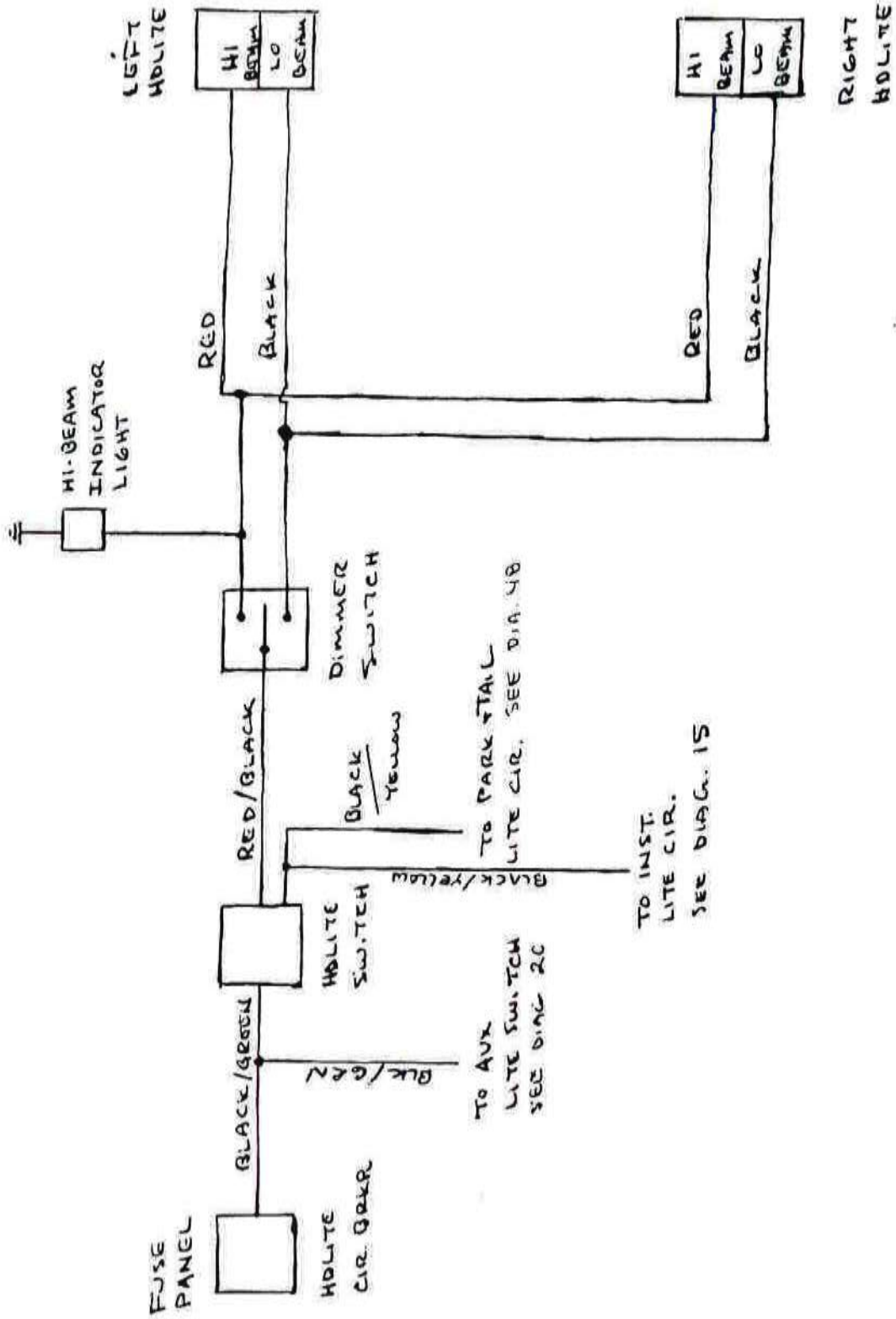

HDLITE CIRCUIT

4 B

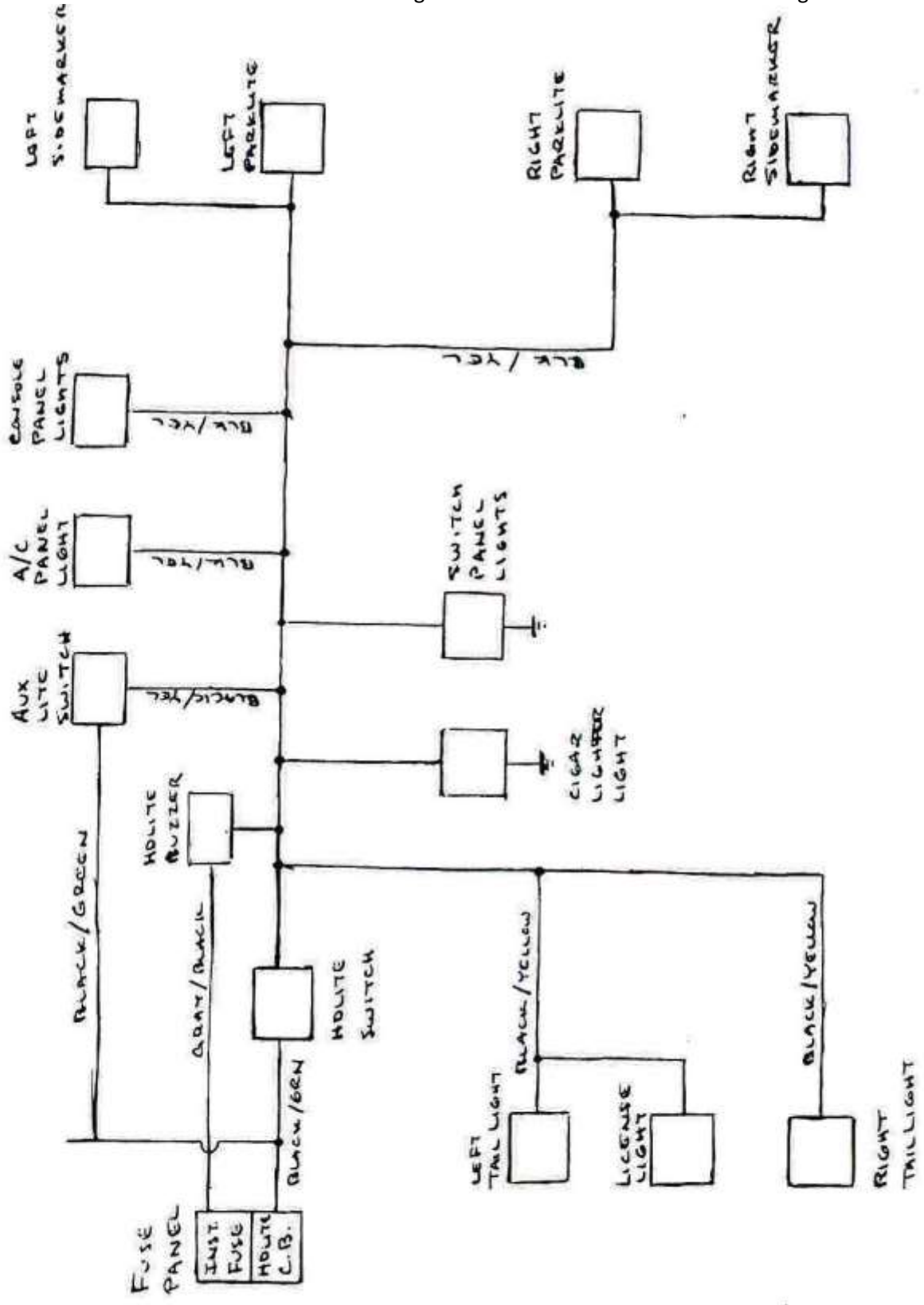

PARK AND TAIL LIGHT CIRCUIT

5A

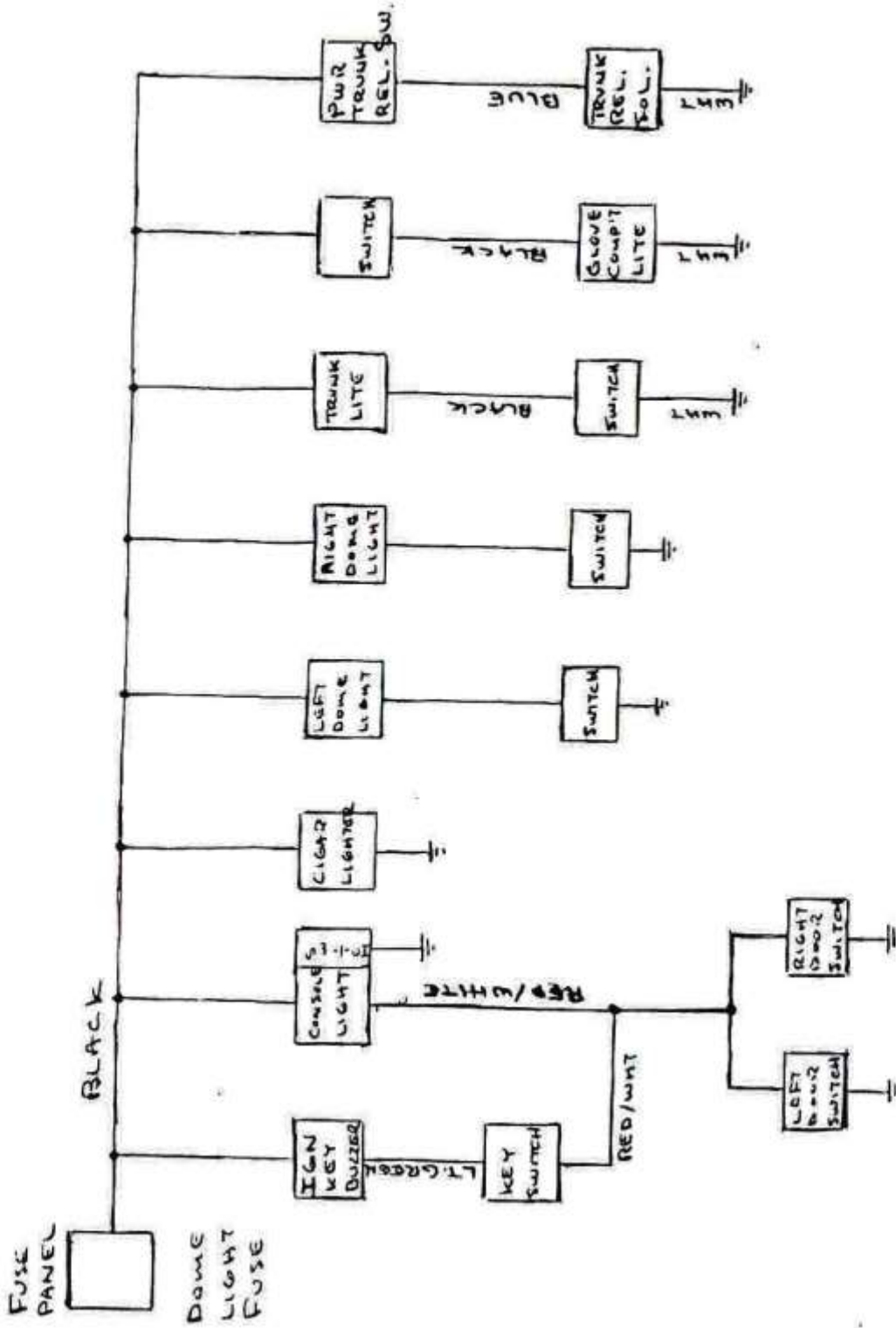

DOME LIGHT FUSE CIRCUIT - 1975 + 1976

5B

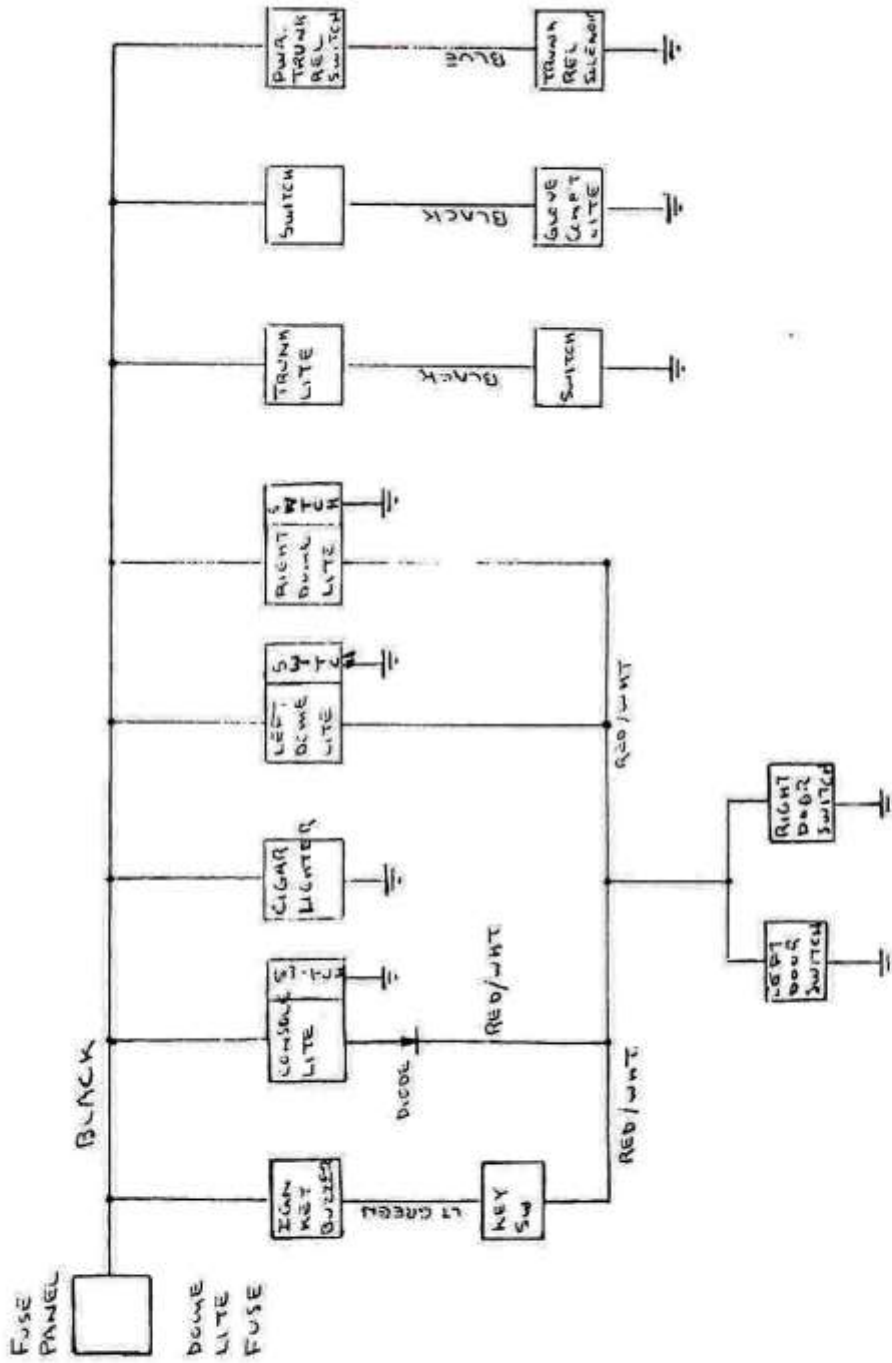

DOME LIGHT FUSE CIRCUIT - 1977

6

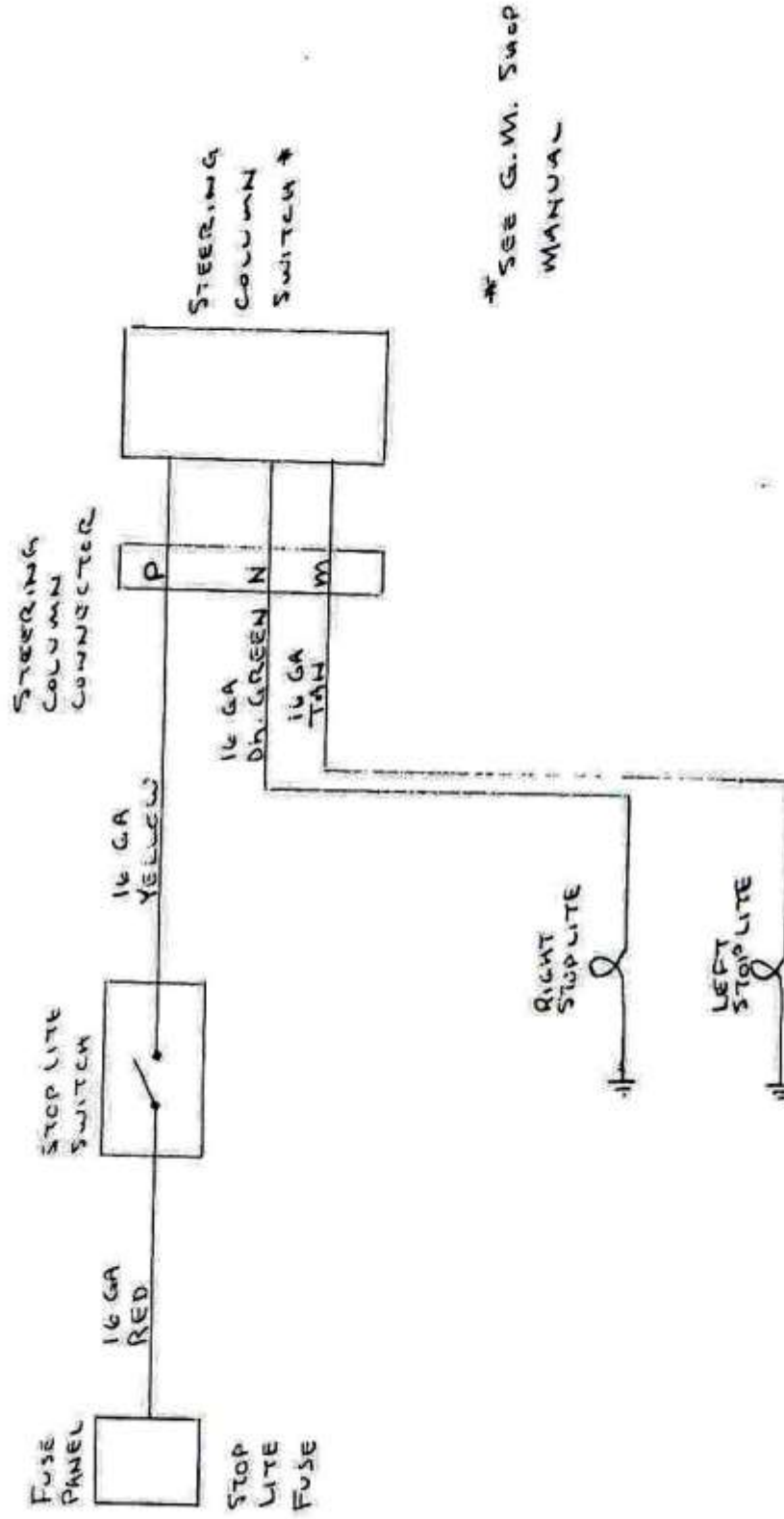

* SEE G.M. SWOP
MANUAL

STOP LIGHT CIRCUIT

7

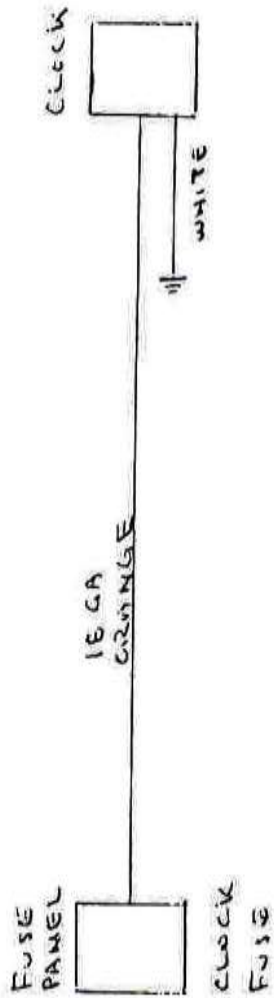

Clock Circuit

8A

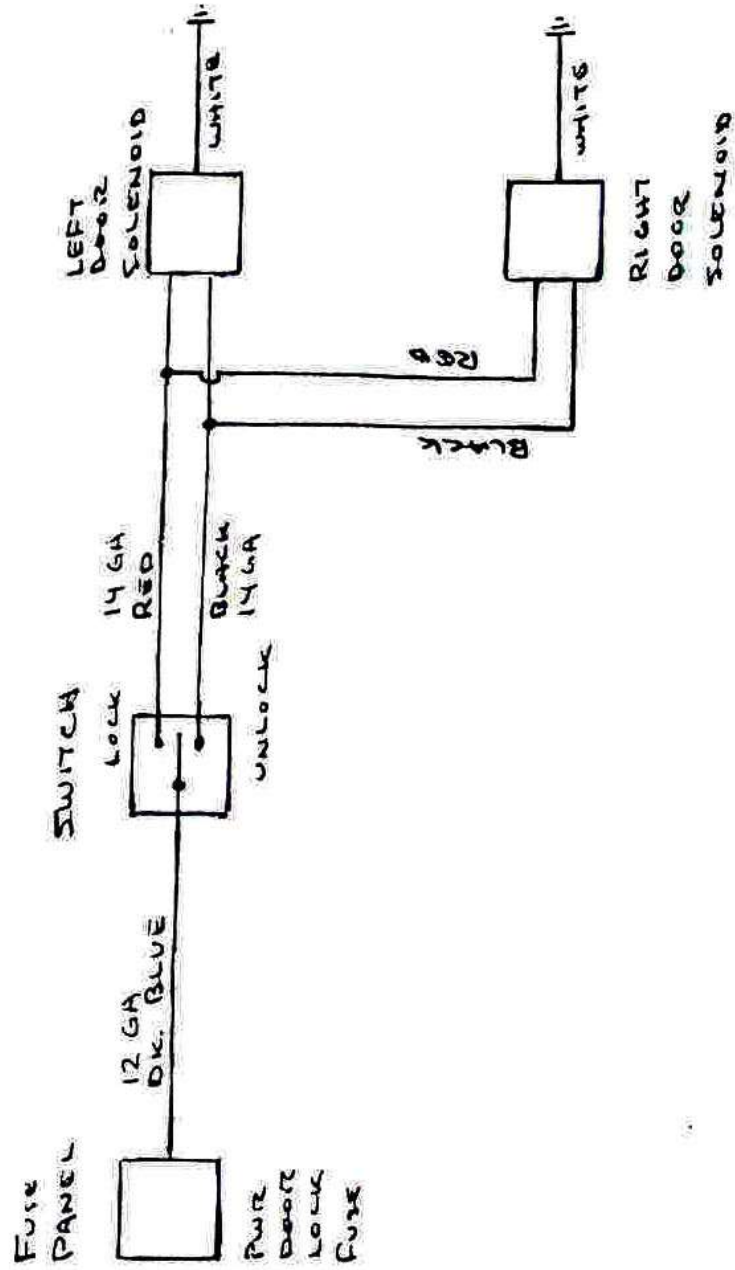

Power Door Lock Circuits

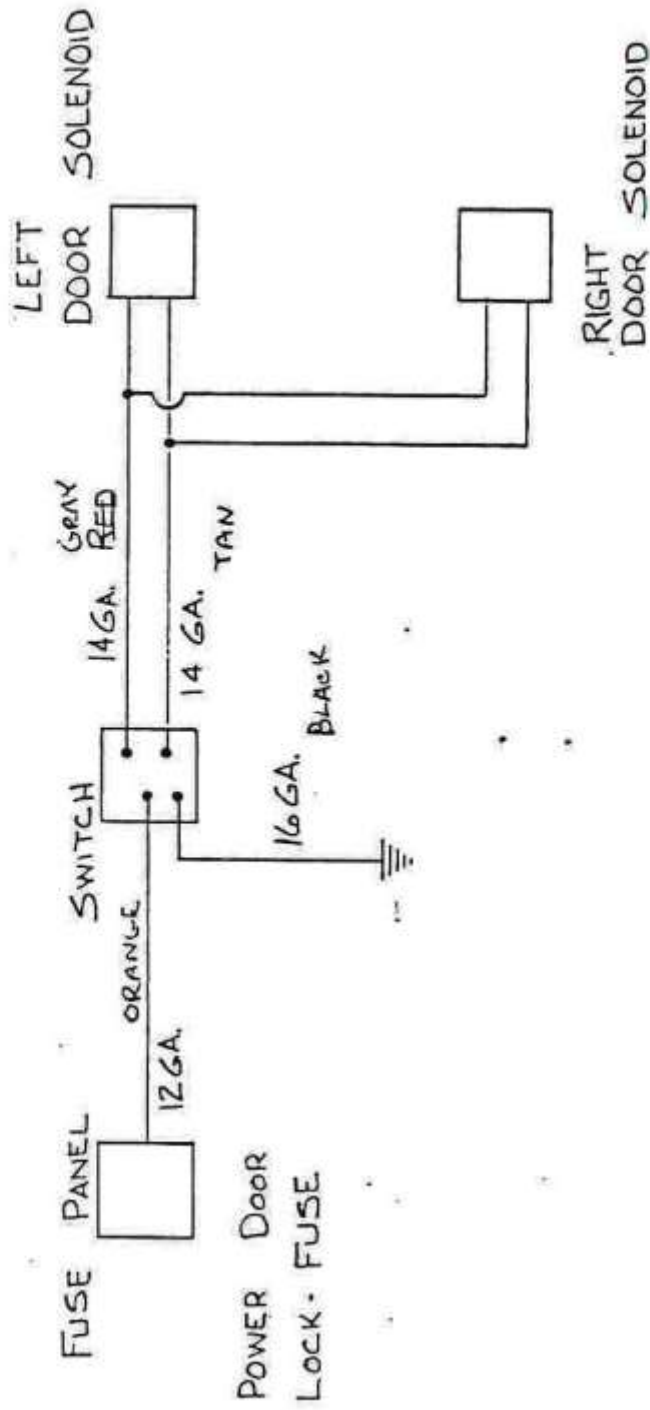

POWER DOOR LOCK CIRCUITS - 1978

9A

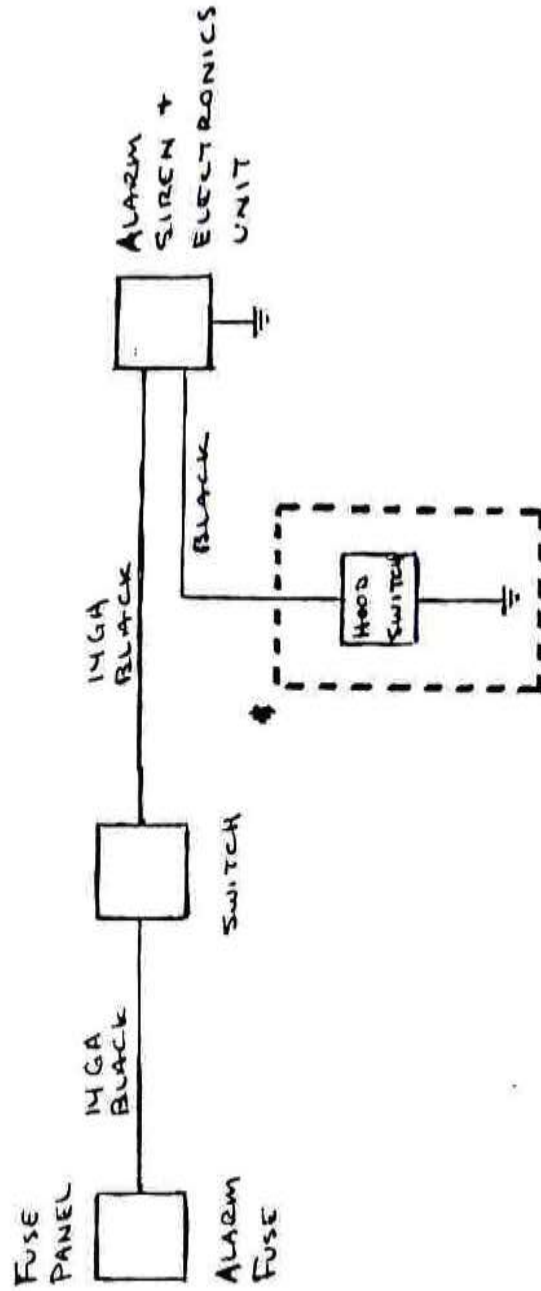

Note :

WITH ALARM INSTALLATION THE ADDITION OF A CAPACITOR ACROSS THE CLOCK TERMINALS IS NECESSARY.

BURGLAR ALARM CIRCUIT

HOOD SWITCH HAS BEEN ELIMINATED. THIS IS DUE TO DIFFICULTY OF MAINTAINING SWITCH ADJUSTMENT AND RESULTANT FALSE ALARM.

9B

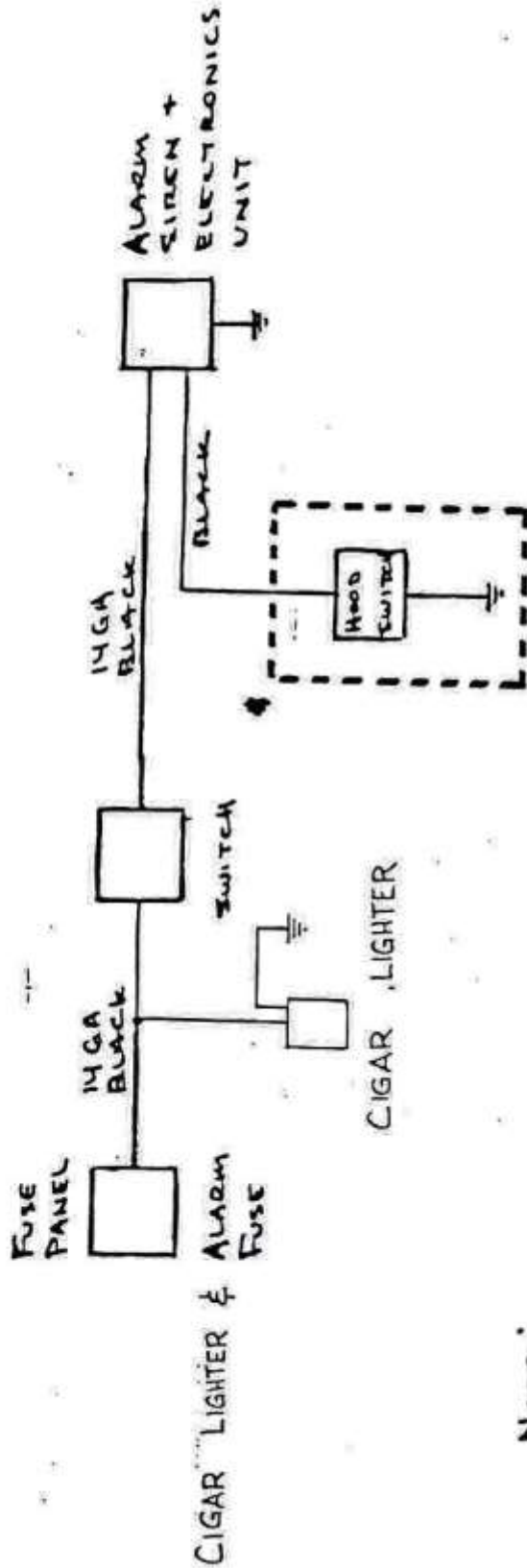

Note:

WITH ALARM INSTALLATION THE ADDITION OF A CAPACITOR ACROSS THE CLOCK TERMINALS IS NECESSARY.

CIGAR LIGHTER
AND

BURGLAR ALARM CIRCUITS

Hood Switch HAS BEEN ELIMINATED. THIS IS DUE TO DIFFICULTY OF MAINTAINING SWITCH ADJUSTMENT AND RESULTANT FALSE ALARM.

10c

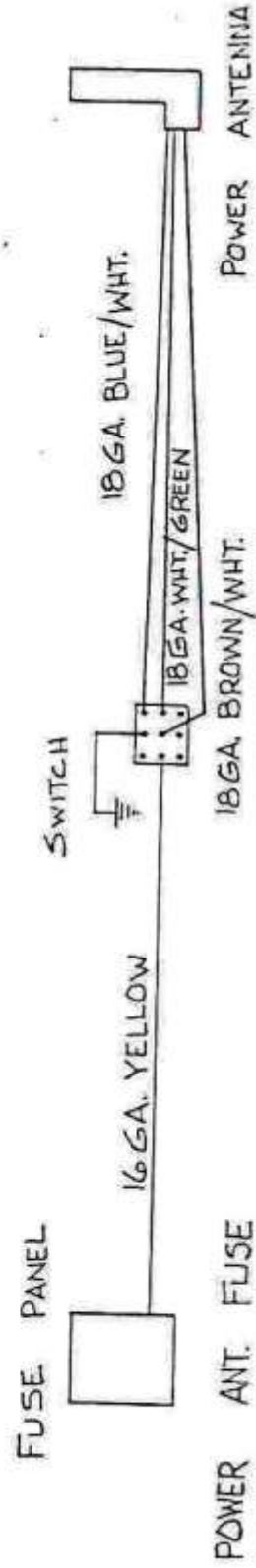

ELECTRIC ANTENNA CIRCUIT
(HARADA - 1980)

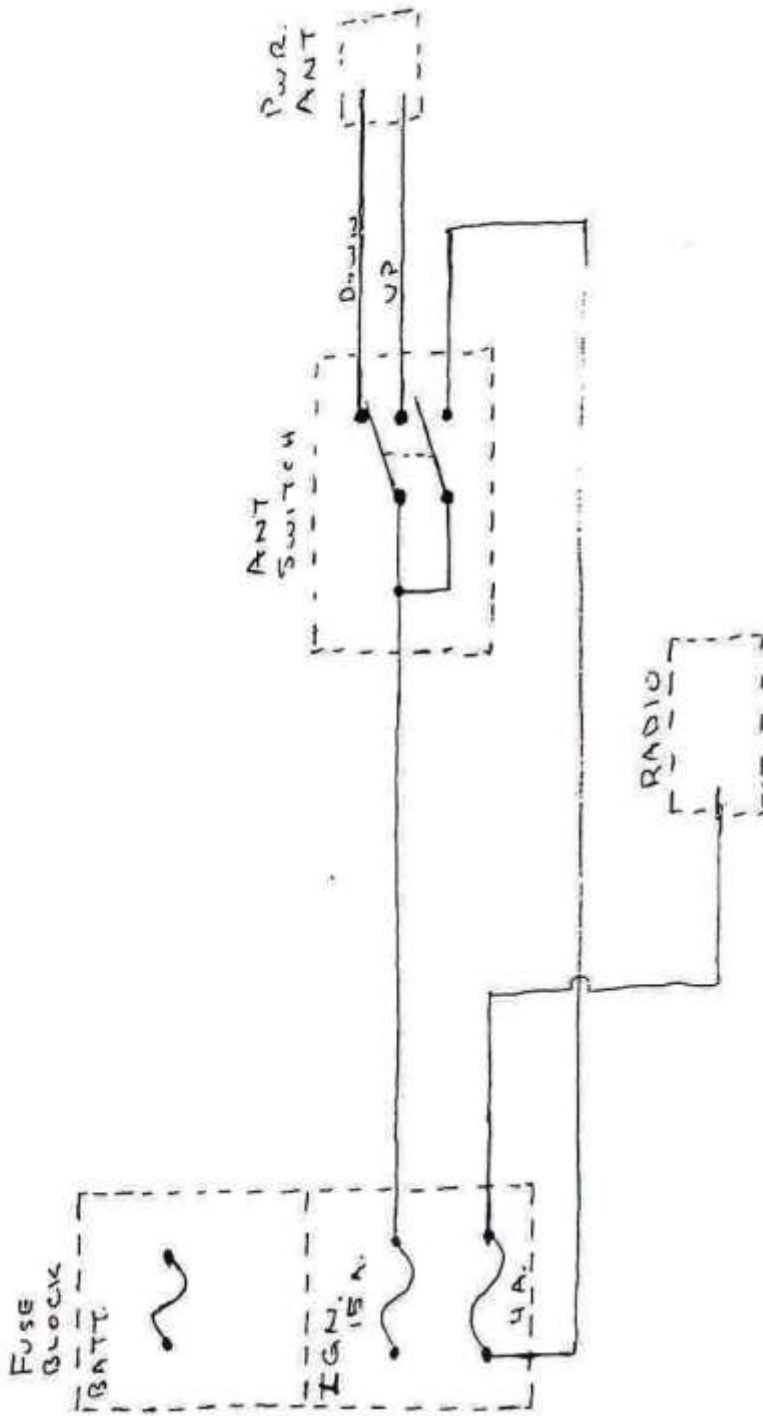

ANTENNA SWITCH DIAGRAM

11

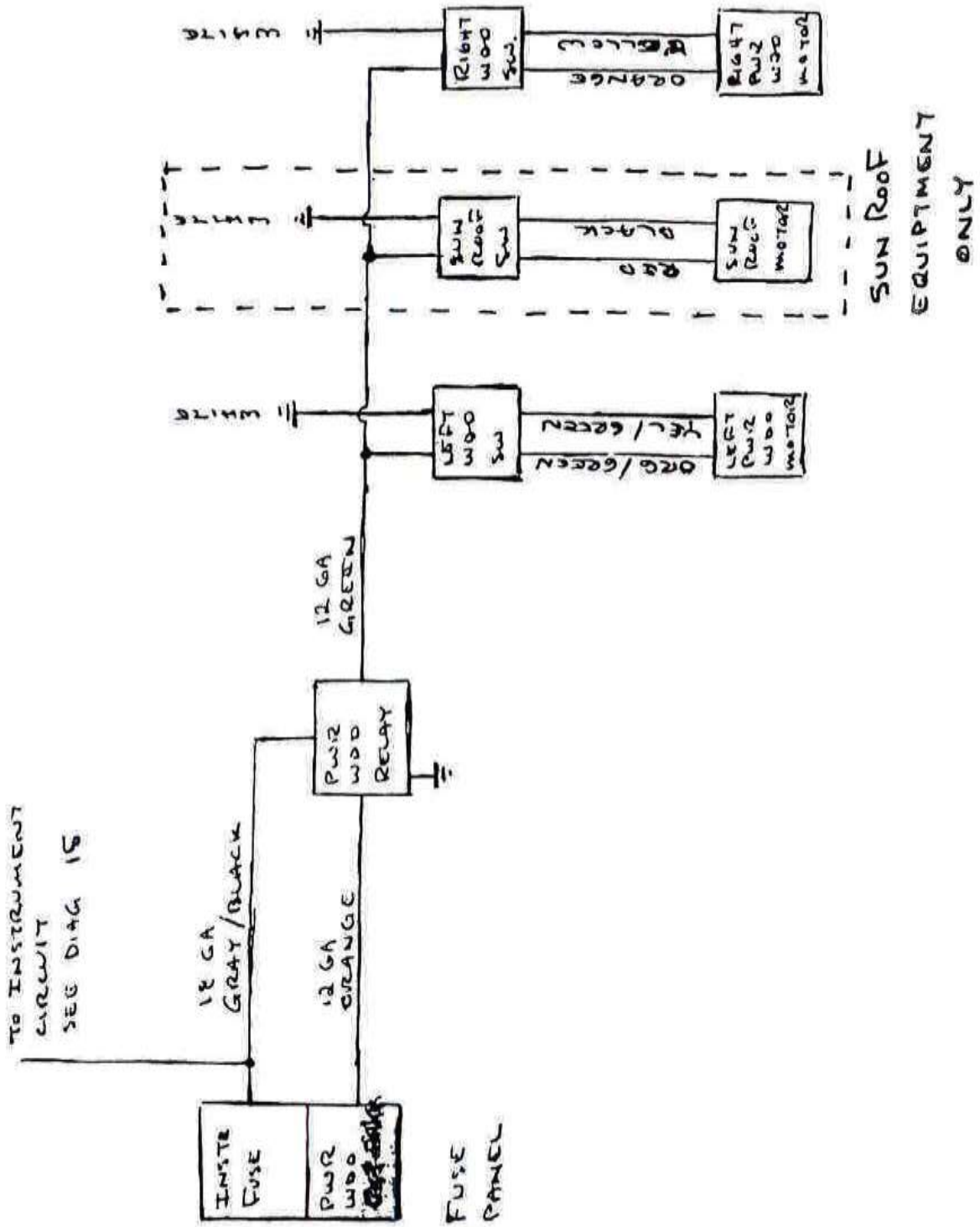

Power Windows and Sun Roof Circuit

13

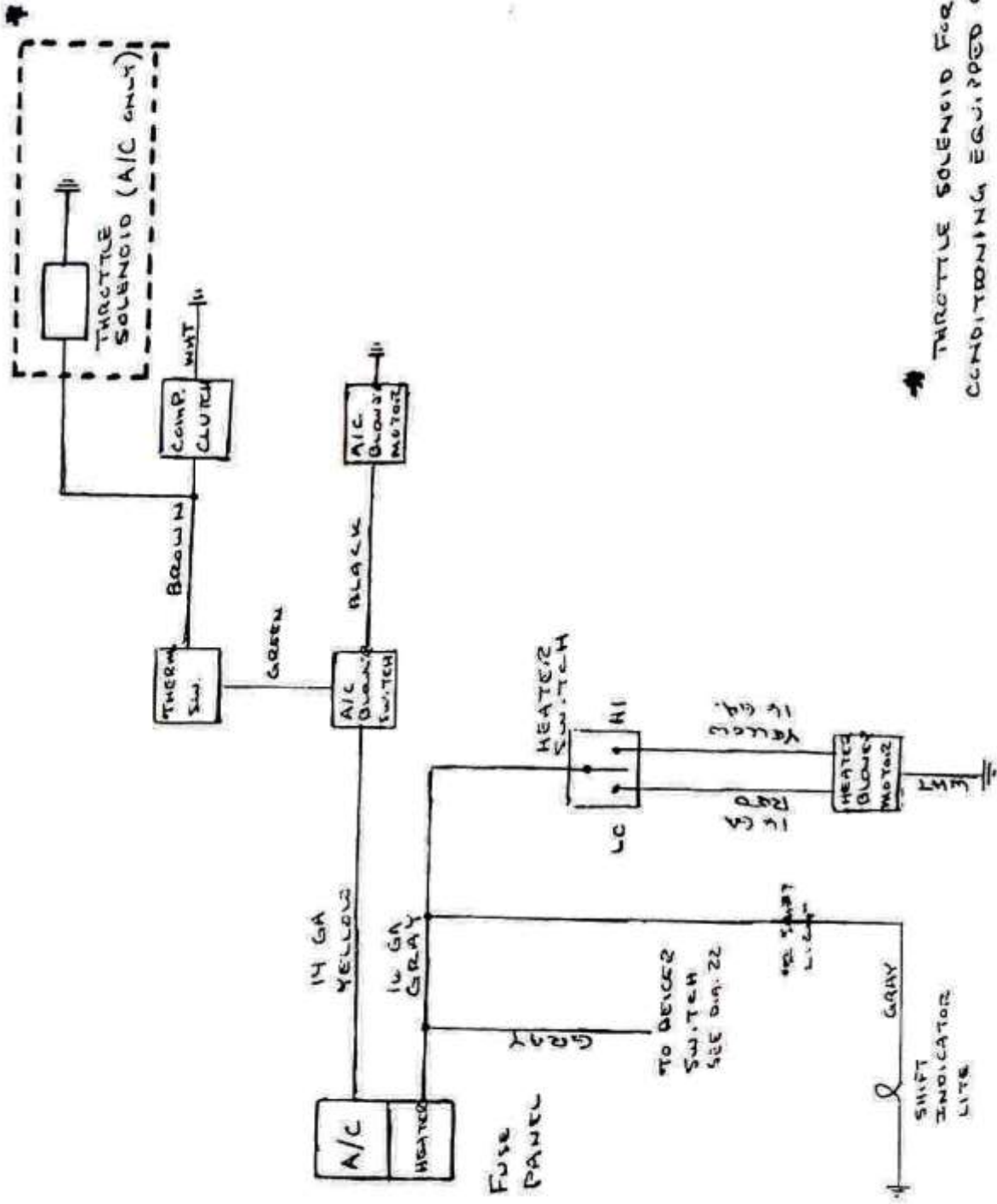

THROTTLE SOLENOID FOR AIR
 CONDITIONING EQUIPPED CARS
 ADDED WITH 1977 MODEL.

A/C and HEATER CIRCUITS

14

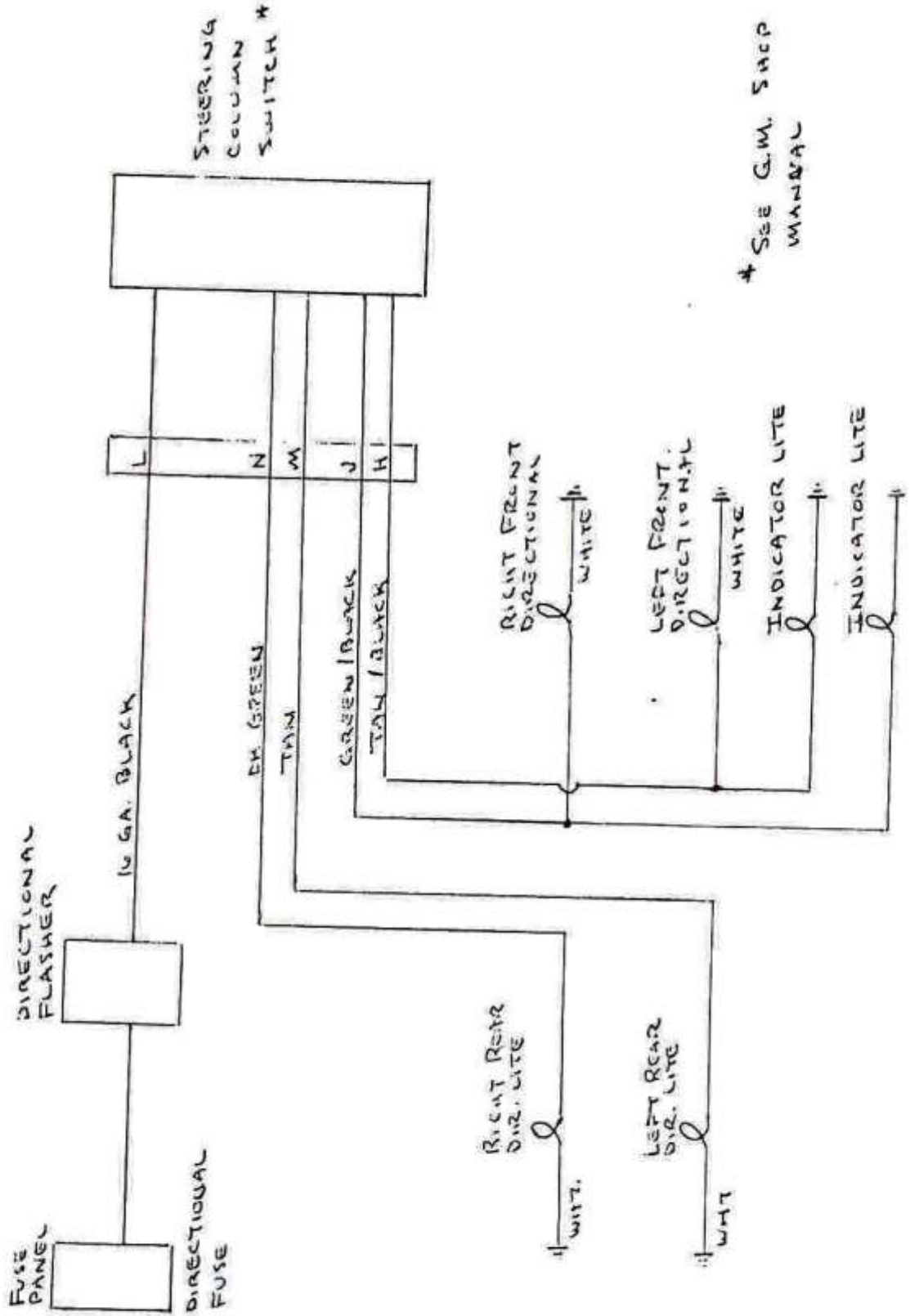

* See G.M. SHOP MANUAL

DIRECTIONAL CIRCUIT

15A

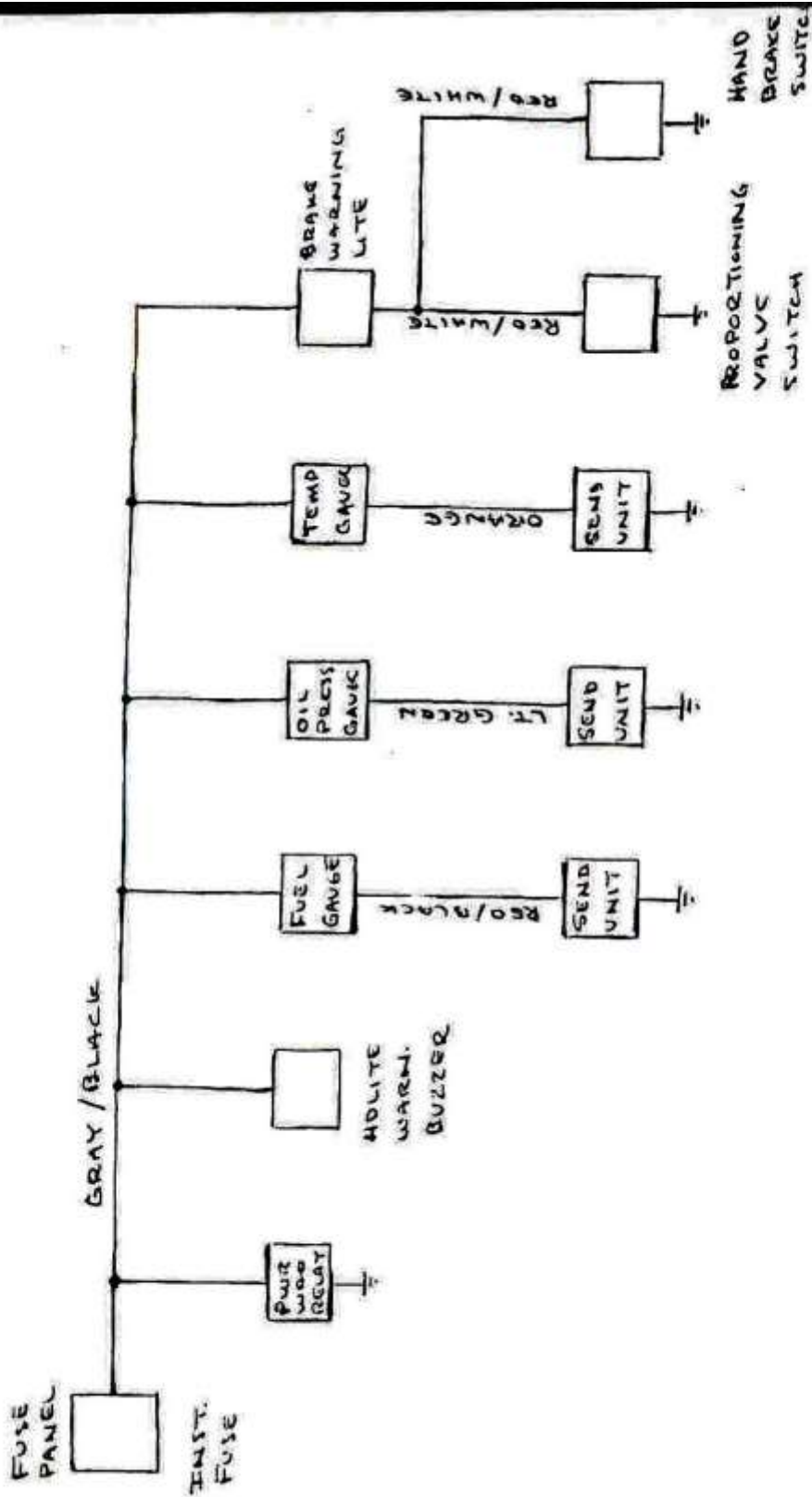

INSTRUMENT FUSE CIRCUIT

NOTE:

BEGINNING WITH 1977 MODEL YEAR BRAKE WARNING LIGHT CIRCUIT COLOR CODING CHANGED TO YELLOW/BLACK, WAS RED/WHITE.

15B

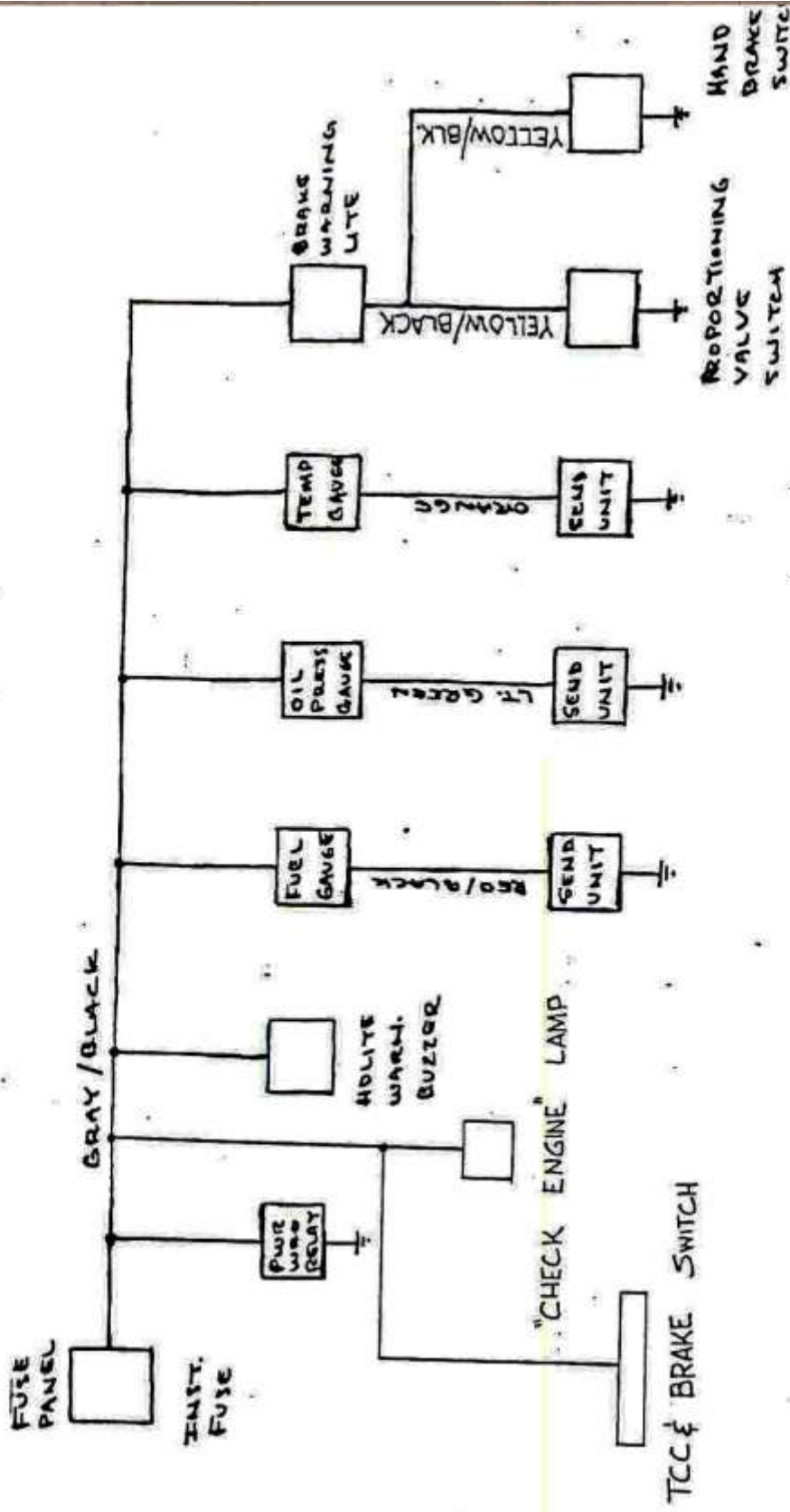

Instrument Fuse Circuit - 1981

Note:

BEGINNING WITH 1977 MODEL YEAR BRAKE WARNING LIGHT CIRCUIT COLOR CODING CHANGED TO YELLOW/BLACK, WAS RED/WHITE.

16A

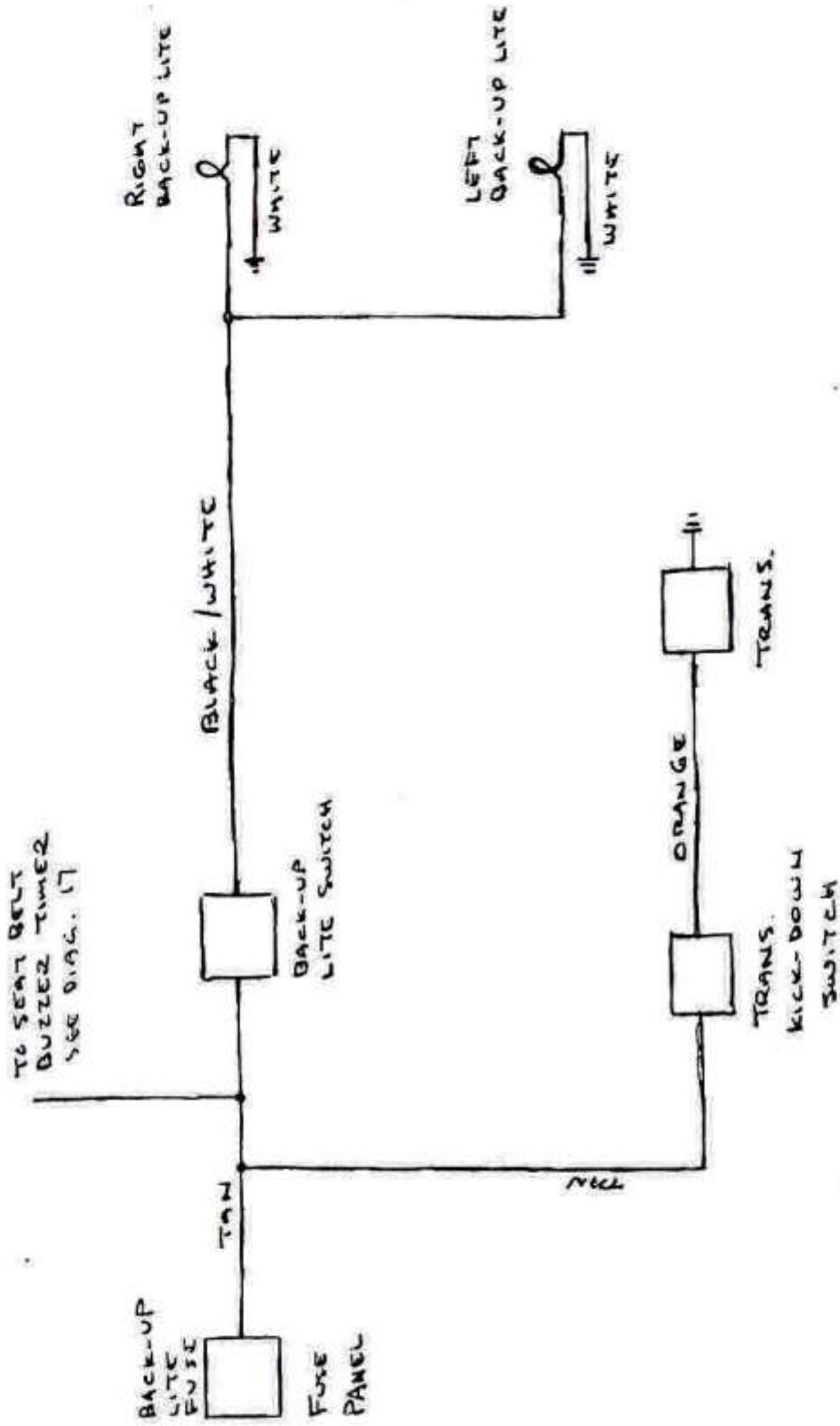

BACK-UP LITE AND TRANSMISSION KICK-DOWN CIRCUIT

16B

TO SEATBELT BUZZER TIMER

SEE DIAG. 17

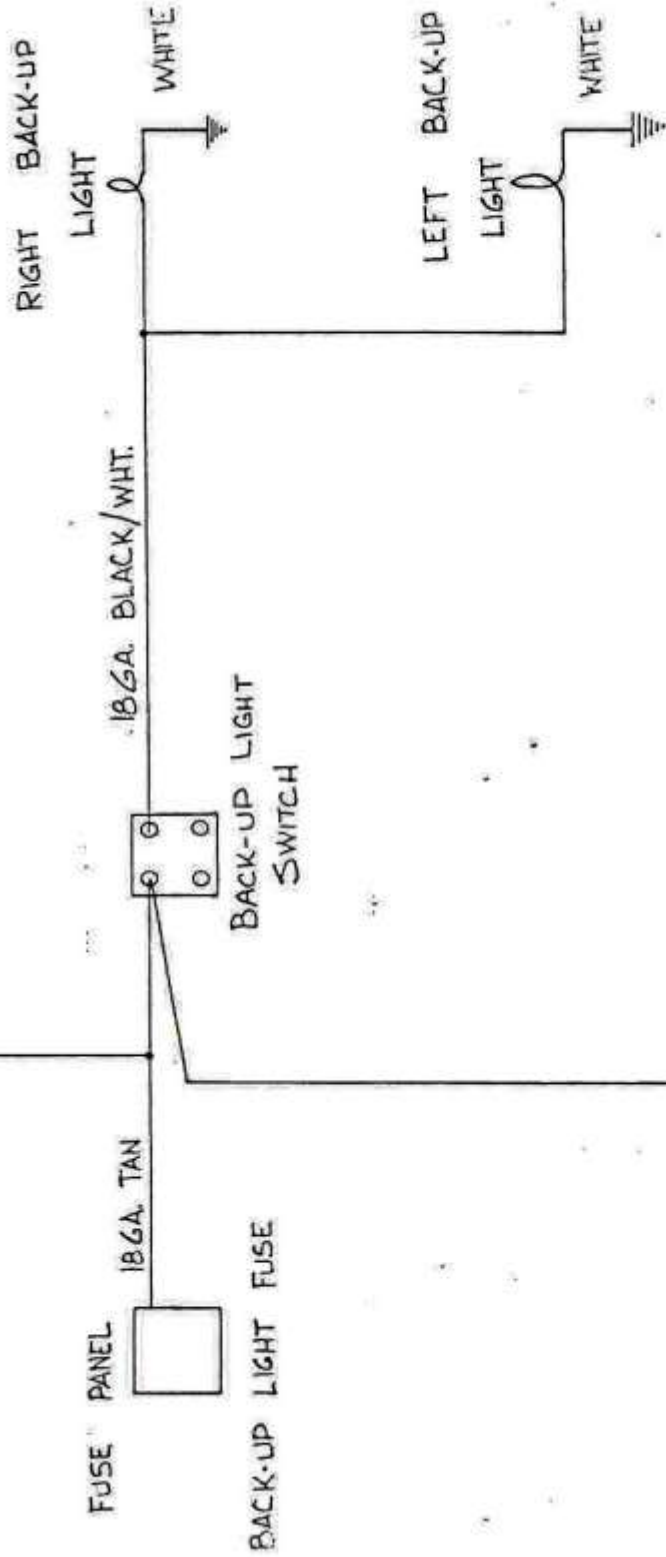

18GA. DK. BLUE - TO CCC. CONN.

BACK-UP LIGHT CIRCUIT - 1281

17A

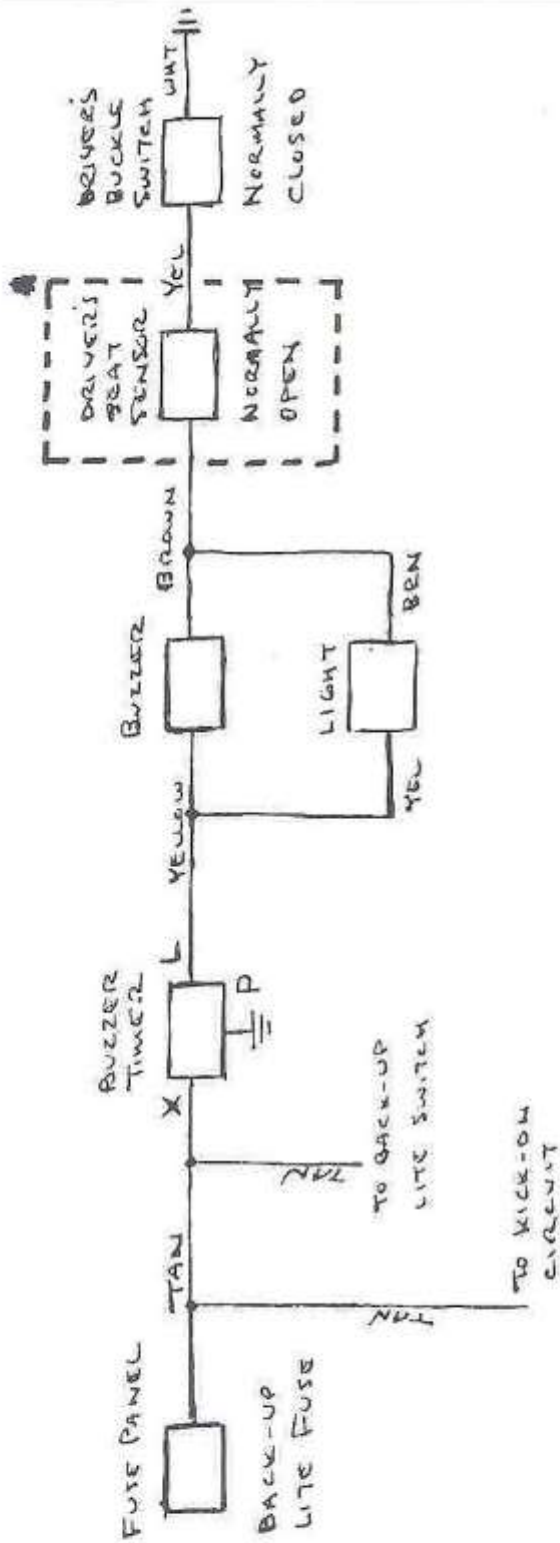

SEAT BELT LIGHT + BUZZER SYSTEM - 1975 + 1976

* DRIVER'S SEAT SENSOR ELIMINATED

178

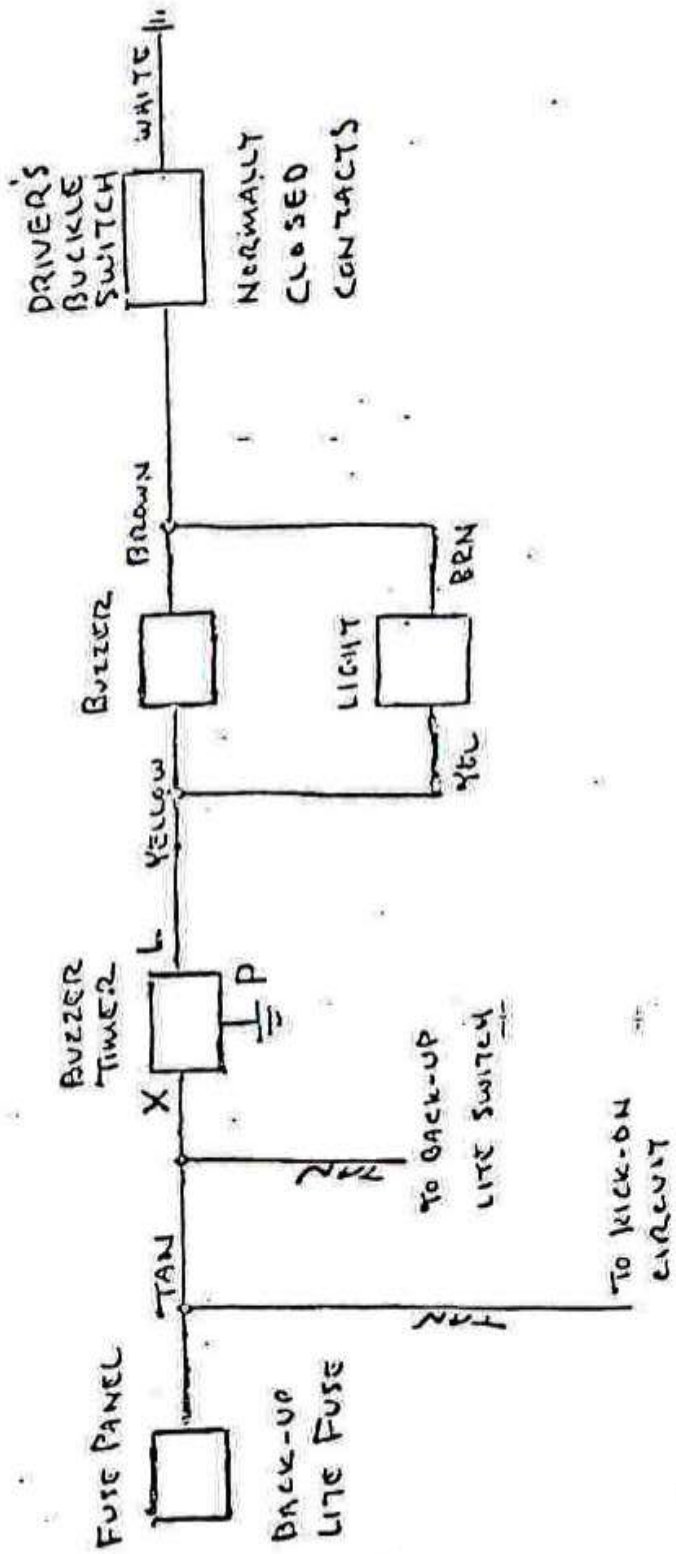

SEAT BELT LIGHT + BUZZER SYSTEM - 1977

18C

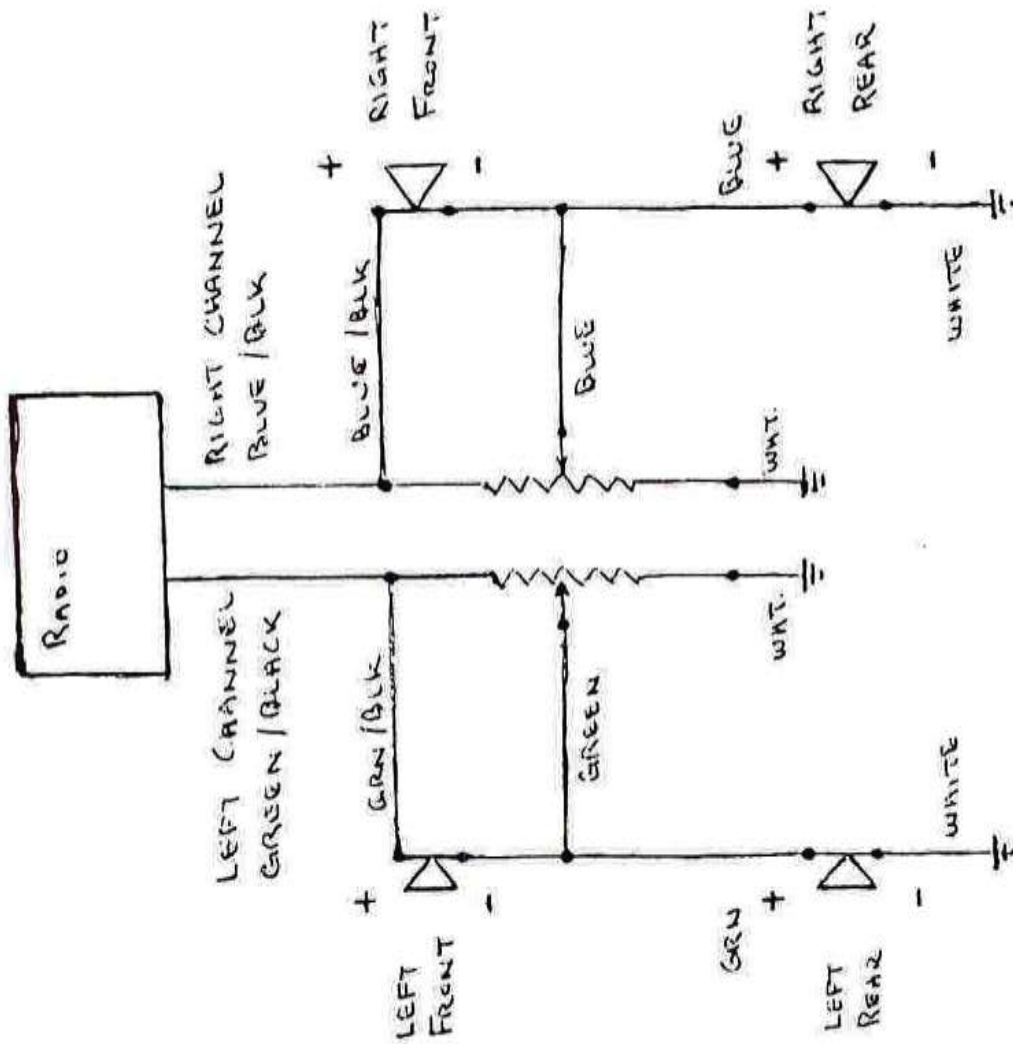

RADIO CIRCUIT DIAGRAM - 1977

19A

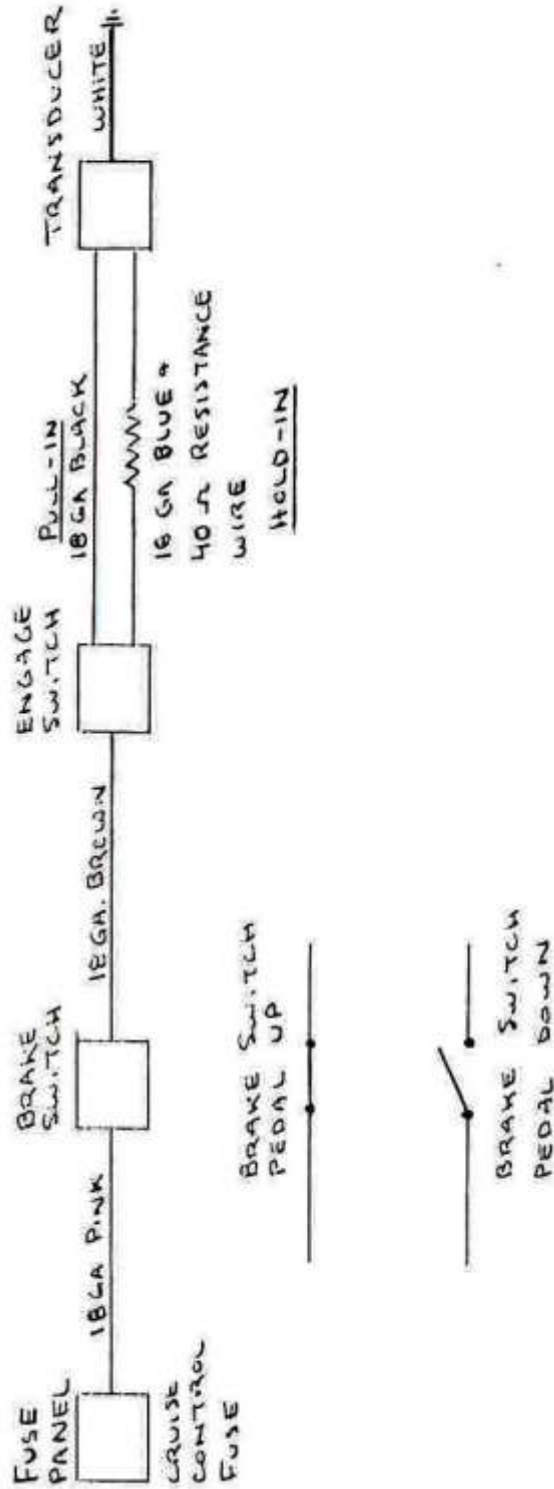

CRUISE CONTROL - 1976 A.C. TYPE *

* SEE ALSO G.M. SHOP MANUAL

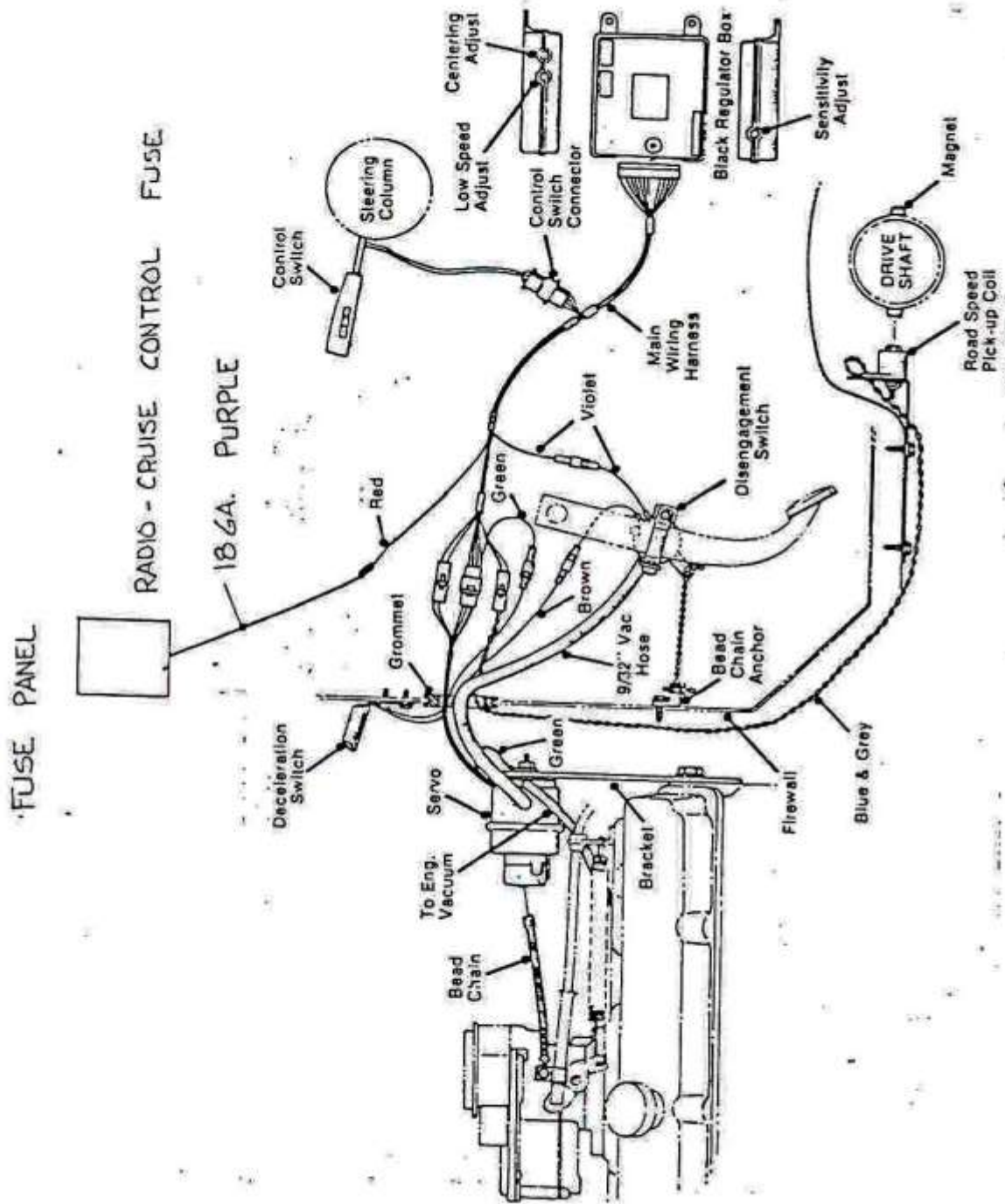

DANA ELECTRONIC CRUISE CONTROL - 1981

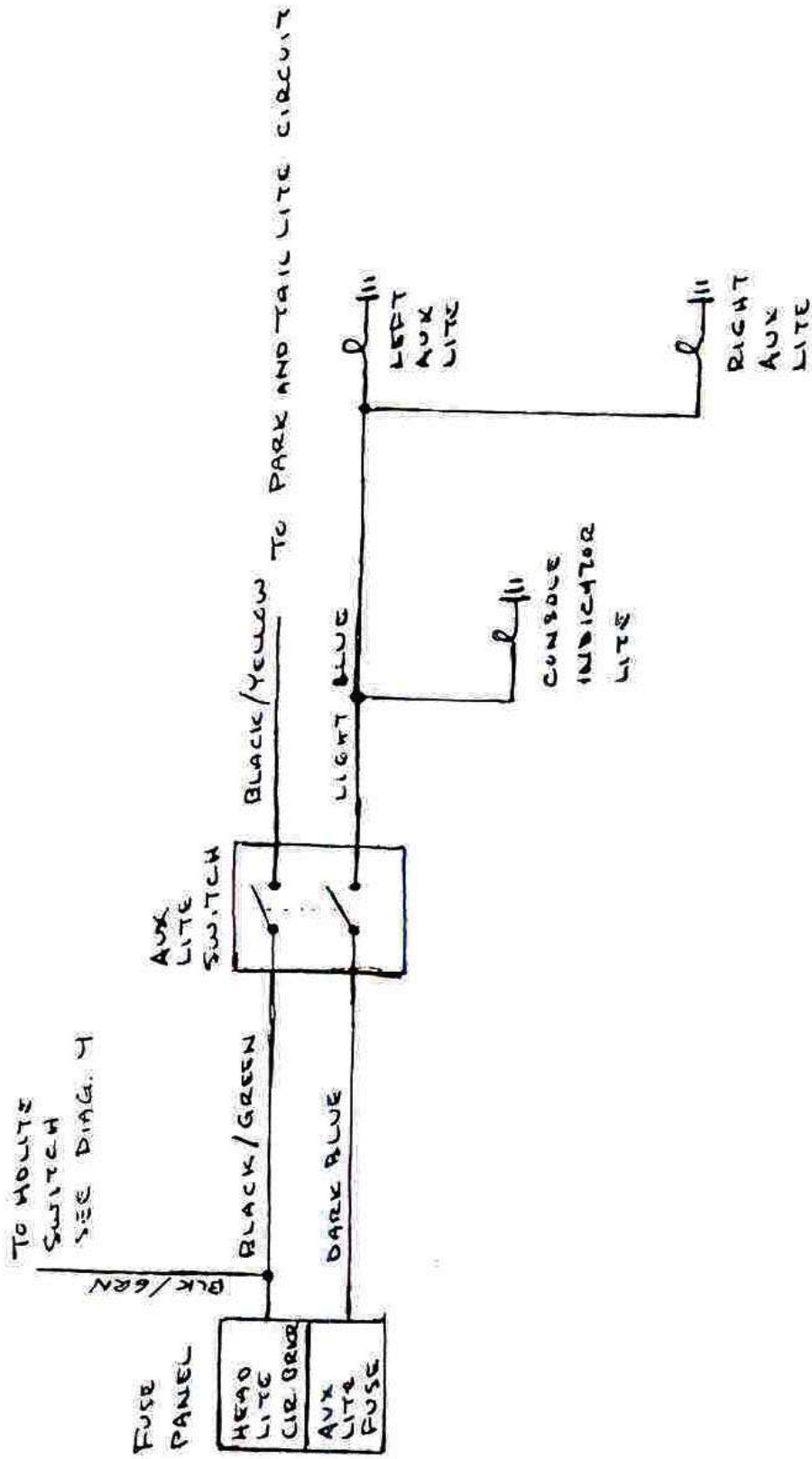

Aux. Light Circuit

ZID

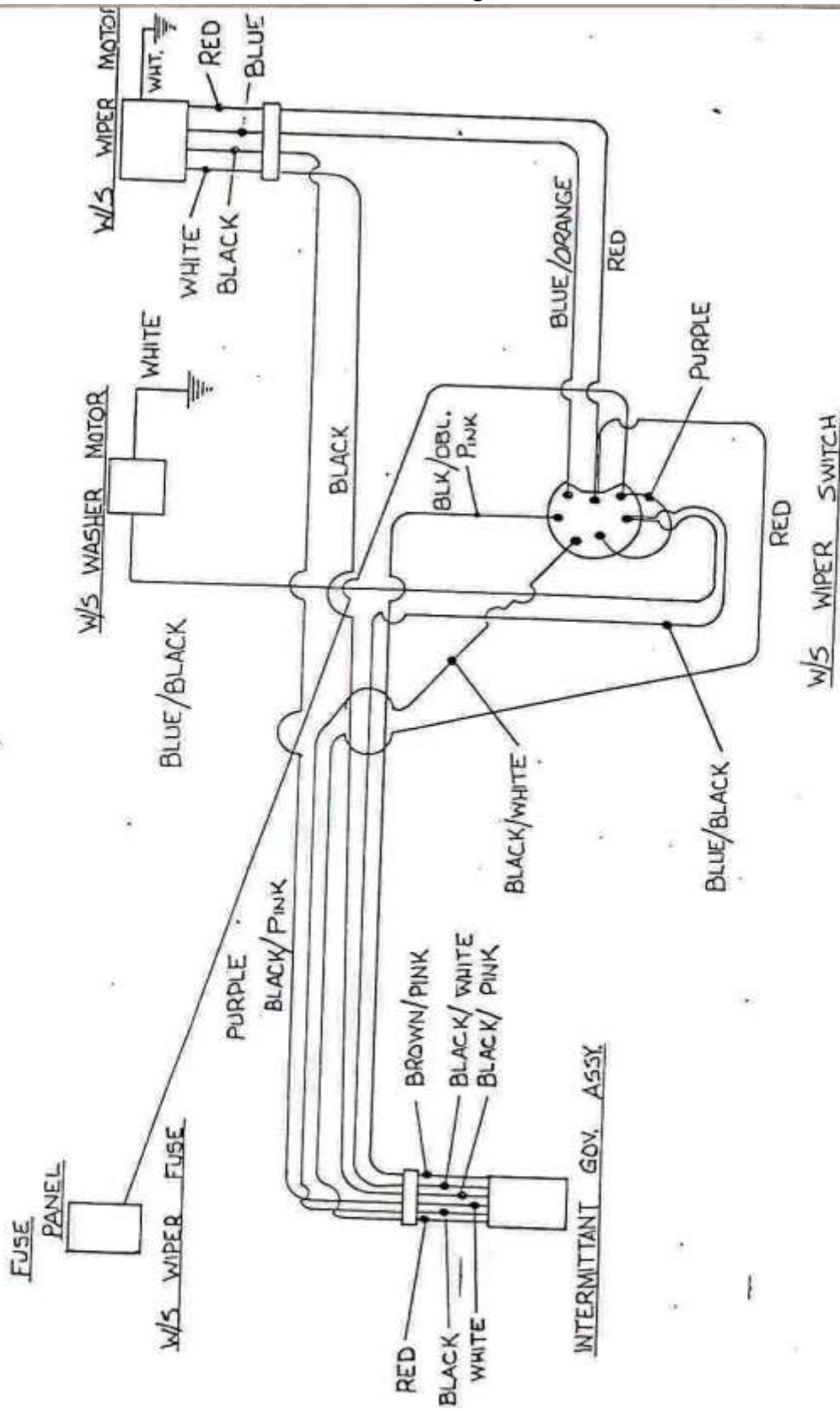

W/S WIPER-WASHER W/INTERMITTANT CIRCUIT - 1981

22 A

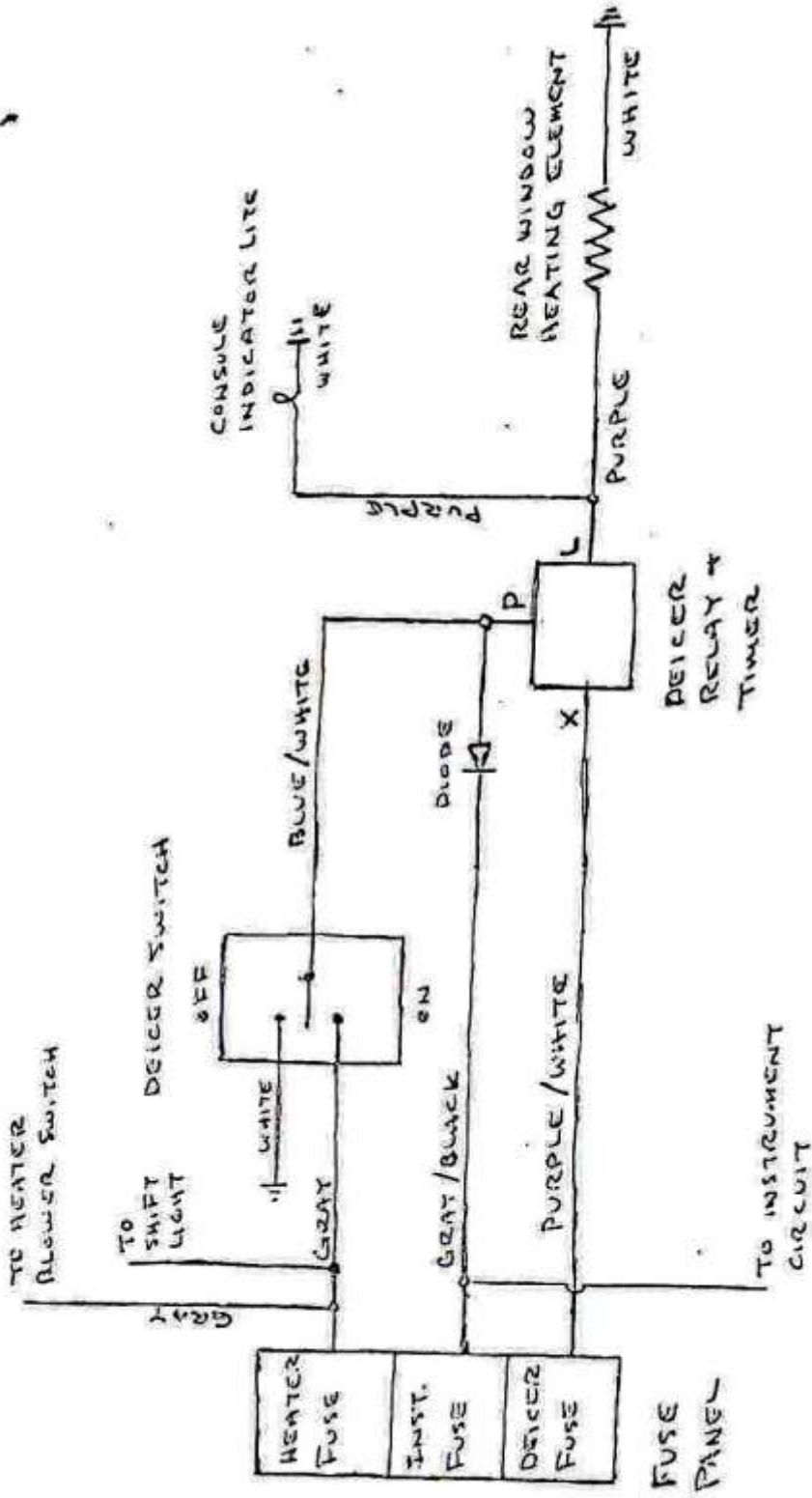

REAR WINDOW DEICER SYSTEM

228

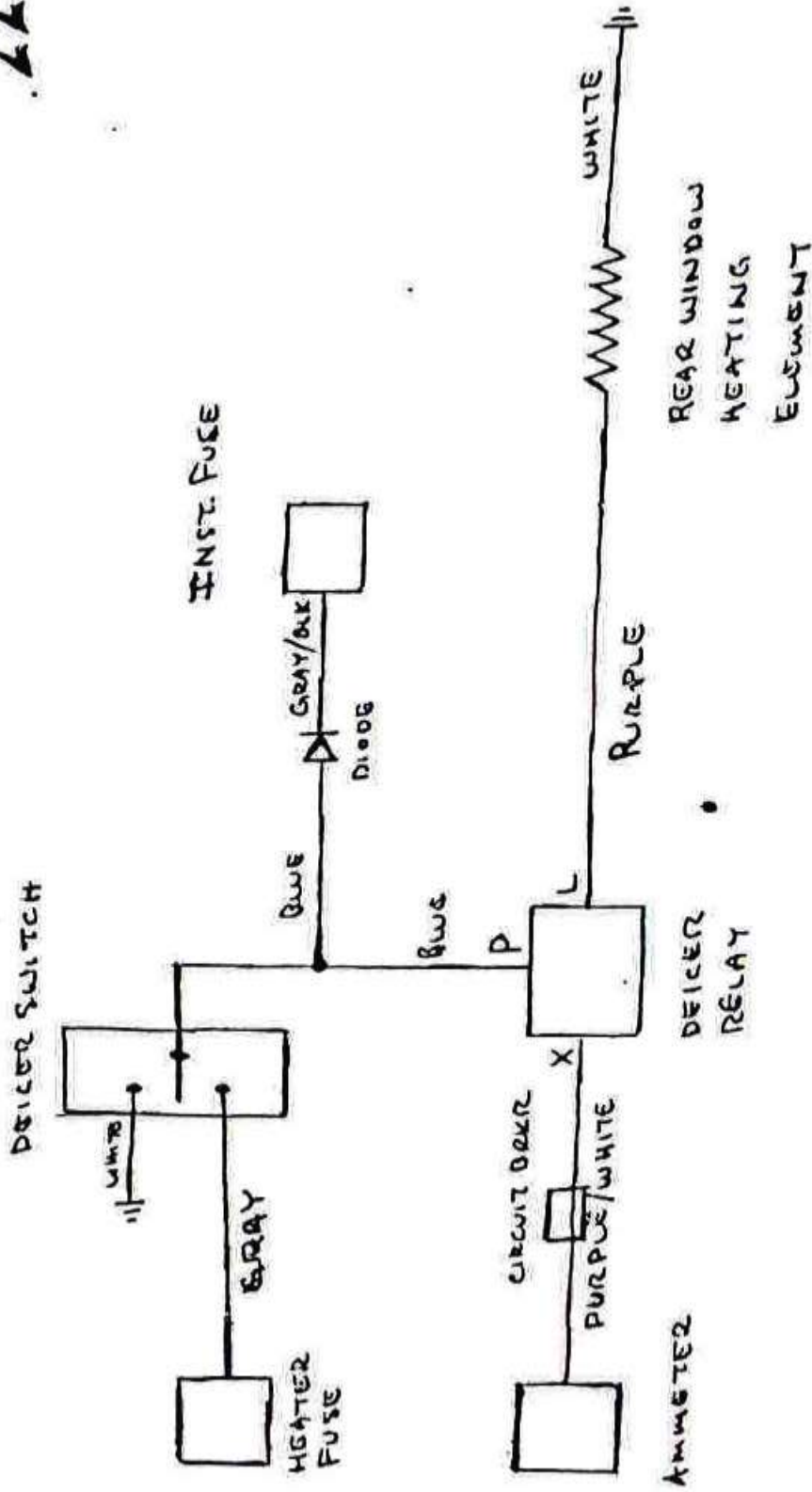

SUGGESTED INSTALLATION

REAR WINDOW DEICER - '63 + 64 models

DEICER OPERATION

The Deicer Switch is mounted on the console. To the left of the ^{SEAT} belt light is a pilot light which indicates when the deicer is on. Turn the Deicer on by pressing the switch to the forward position, when released, it will return to the center position. The Deicer will remain ON for approximately ten minutes and switches off automatically. Pressing the switch to the on position during system operation does not extend operating time. The Deicer may be turned off by pressing the switch to the rearward position or by turning the ignition switch off. The Deicer may be turned on with the ignition switch in the engine run position only.

DEICER CIRCUIT DESCRIPTION

The Deicer Circuit may be divided into two components, the relay switching circuit and the rear window feed circuit.

The rear window feed circuit consists of a 30 amp Deicer fuse and the Deicer relay-timer. The Deicer fuse is feed directly from the battery line and is always hot. It in turn feeds the relay-timer (via purple/white) at the X terminal. The relay serves two purposes. First, to switch the operating current for the rear window. Second, with its electronic clock circuit, to provide for automatic shut off of the window after approximately ten minutes.

A 12 volt pulse to the relay ^P terminal turns the relay on. Grounding the relay P terminal shuts the relay off. Turning the relay on connects the X and L terminals providing current flow to the window via the purple and to ground via the white. The console life is connected to the purple to indicate when the window is in operation.

The switching circuit consists of the Deicer switch, a diode and two feed lines from the fuse panel. The heater fuse line (gray) provides 12 volts for turning on the relay. This fuse is HOT only when the ignition key is in the engine run position, thus the system can only be turned on at this time. Pressing the Deicer switch to the on position provides a 12 volt pulse (via blue/white) to P terminal of the relay, which turns it on. Pressing the switch to the off position grounds (via white) the P terminal and shuts the relay off, thus providing manual as well as automatic shutoff.

To prevent the Deicer from remaining on when the key is shut off, a diode and line to the instrument fuse are provided. With the Deicer on and the ignition key in the engine run position, the instrument fuse line (gray/black) to the diode is hot. In this case there is no difference of potential between the relay P terminal and the instrument fuse line, the relay remains on. When the ignition key is shut off, the instrument fuse is no longer hot. A difference of potential then exists between the P terminal and the fuse line. The P terminal 'sees' the fuse line as ground and the relay is shut off. The diode allows current to flow from the P terminal to the fuse line to shut the relay off. It does not allow current to flow from the fuse line to the P terminal as this would turn the relay on any time the fuse line was hot.

DEICER PROBLEM DIAGNOSISPROBLEM

Deicer Does not Work - indicator light on.

Deicer does not work - indicator light off.

Deicer does not work - indicator light off -
Deicer and heater fuses good.

Deicer does not work - indicator light off -
Deicer and heater fuses good - 12 volts not
present at P terminal when switch is
operated.

Deicer works - does not shut off when key is
shut off.

Deicer works - does not shut off automatically.

Relay will not stay on.

POSSIBLE CAUSE

Check for loose connections at rear window.

Check for poor or corroded ground connection,
right rear body hold down bolt. This is under
carpet adjacent to the spare tire.

Check for loose connection at I.P. to chassis
harness connector. This is near firewall on the
left side of Air Conditioner. Check the eight
terminal connector with the 12 gauge purple
Deicer feed line in it.

Check Deicer fuse.

Check Heater fuse.

Operate Deicer switch while checking for 12 volts
at relay P terminal. If 12 volts is present a
faulty relay is indicated. The relay is located
above the driver's fresh air vent and has a
purple, a purple/white and blue/white wires
attached to it.

Check for loose connection at Deicer switch.

Check for faulty switch.

Check for faulty diode. This diode is taped
into the harness just ahead of the black con-
nector which plugs into the Deicer relay.
Untape the harness until the diode is exposed.
Splice in a new diode with a value of at least
1 amp at 50 volts, observe polarity.

Faulty relay - timer indicated.

Check instrument fuse,

Check for faulty indicator.

22 D

DEICER PROBLEM DIAGNOSIS - con't

Deicer works - comes on anytime ignition key is turned on.

Console indicator lite not working.

One or more Deicer element lines not working.

DEICER SHUTS OFF AS SOON AS SWITCH IS RELEASED - INST. FUSE 'BLOWS' WHEN SWITCH IS THROWN TO 'OFF' POSITION

Faulty diode.

Replace light bulb.

Check inoperative elements for scratches or other damage which would interrupt current flow. Repair with G.M. Rear Window Deicer Repair Kit.

FAULTY DIODE

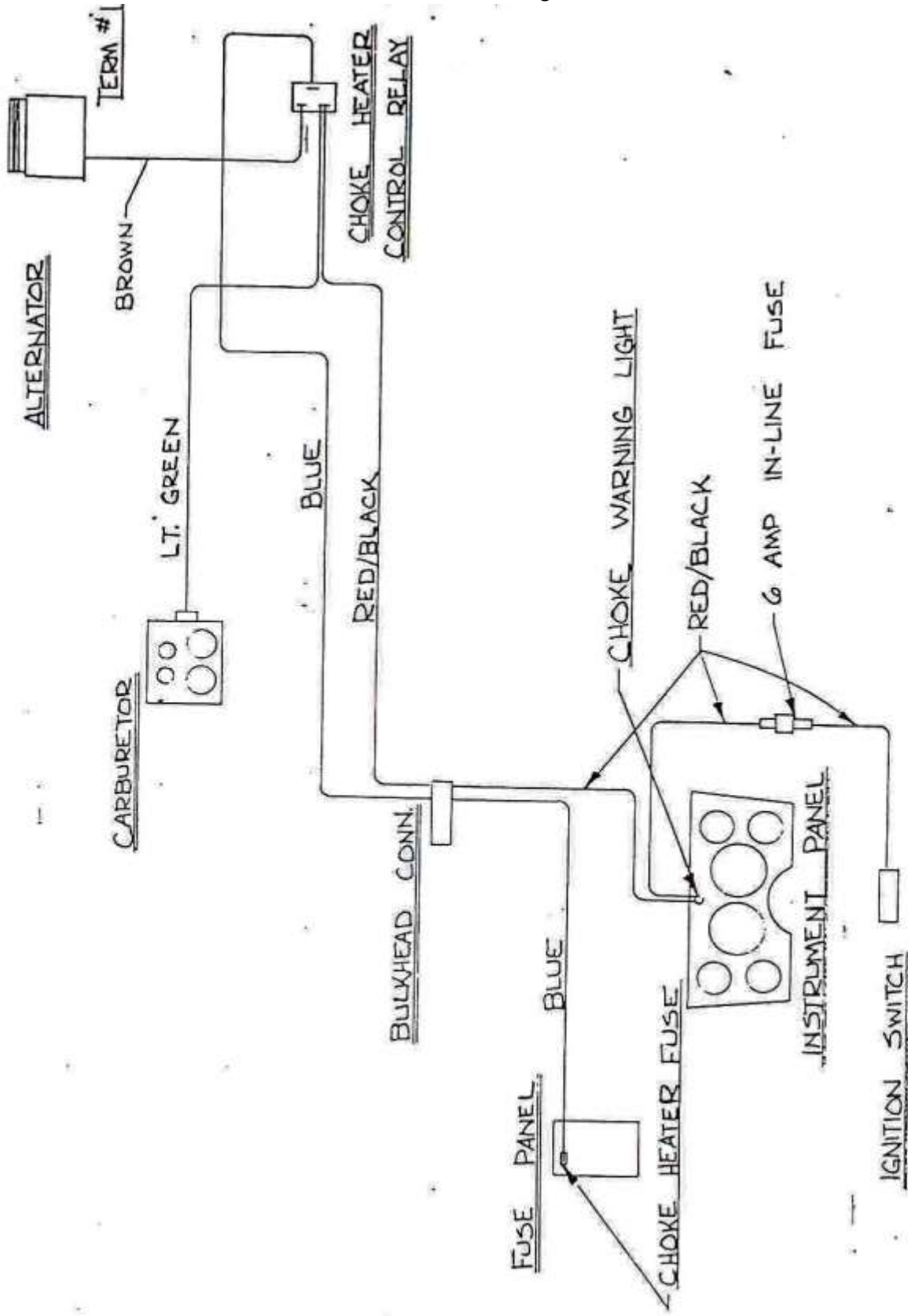

CHOKE HEATER CIRCUIT

24A

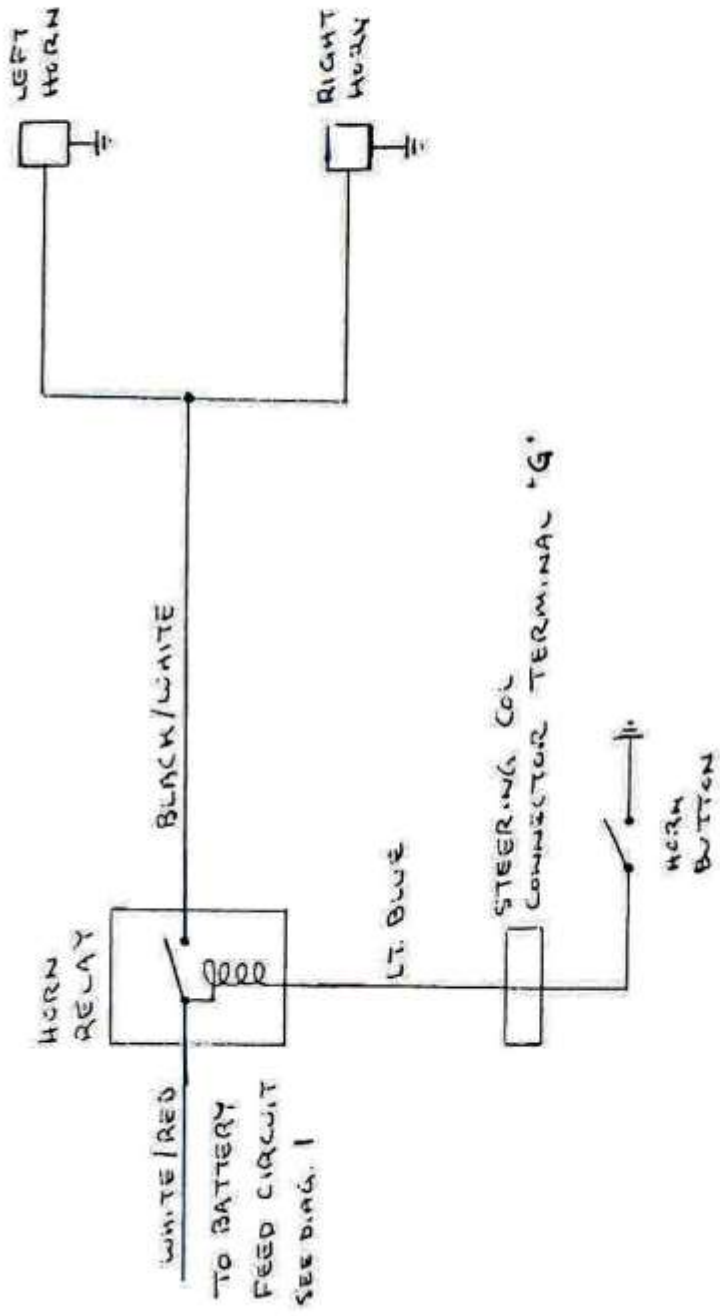

HORN CIRCUIT

24B

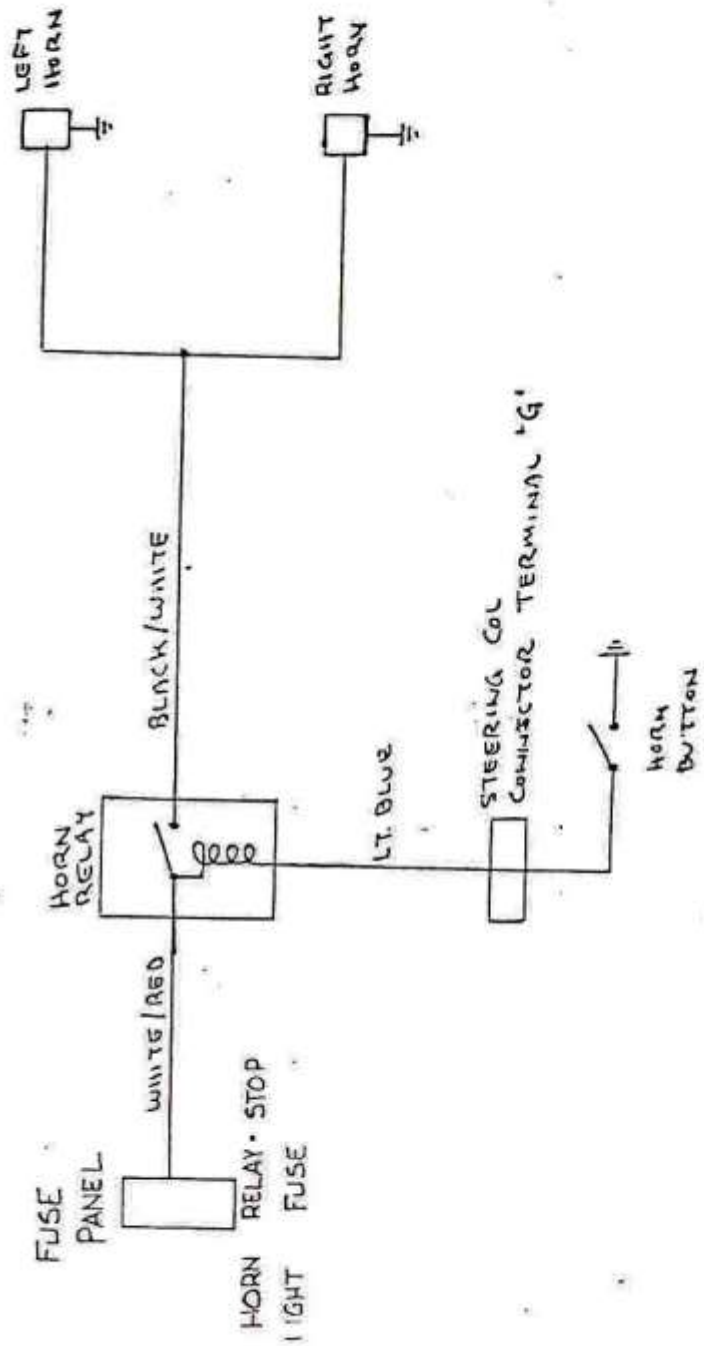

HORN CIRCUIT - 1979

STARTING W/1979 THE HORN AND STOP LITE CIRCUITS ARE CONNECTED TOGETHER WITH A COMMON FUSE

STEERING COLUMN DIRECTIONAL SIGNAL
SWITCH CONNECTOR WIRE PLACEMENT

WIRE TERMINAL	COLOR	CIRCUIT	DIAGRAM NUMBER
D	UNUSED		
E	LT. GREEN	IGN. KEY WARNING	5
F	RED/WHITE	IGN. KEY WARNING	5
G	LT. BLUE	HORN	24
H	TAN/BLACK	LEFT FRONT DIRECTIONAL	12 + 14
	BLANK		
J	GREEN/BLACK	RIGHT FRONT DIRECTIONAL	12 + 14
K	DK. BLUE	HAZARD WARNING FEED	12
L	BLACK	DIRECTIONAL FEED	14
M	TAN	LEFT REAR - STOP + DIR.	12 - 14 - 6
N	DK. GREEN	RIGHT REAR - STOP + DIR.	12 - 14 - 6
P	YELLOW	STOP LAMP FEED	6

1984 FUSE BLOCK

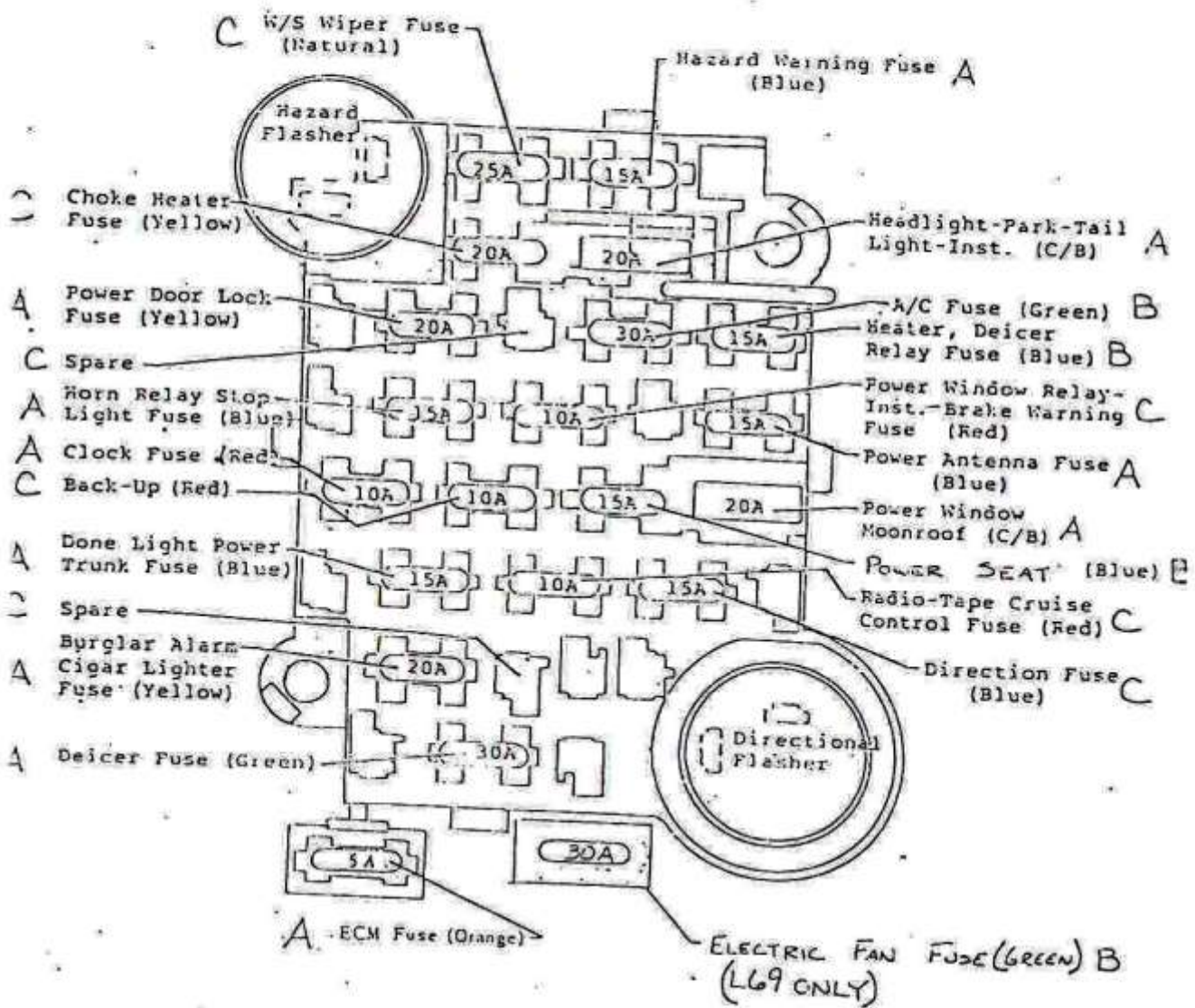

- A - BATTERY FEED
- B - IGNITION FEED
- C - IGNITION & ACCESSORY FEED